

EXISTING TYPICAL SECTION FOR RAMPS

LEGEND

- ① EXISTING HOT-MIX ASPHALT SURF. CSE., ± 5"
- ② EXISTING P.C.C. PAVEMENT, 10"
- ③ EXISTING SUB-BASE GRAN. MATL., 4"
- ④ EXISTING AGGREGATE SUBGRADE, 12"
- ⑤ EXISTING HOT-MIX ASPHALT SHOULDER
- ⑥ EXISTING CONC. BINDER CSE. MIX B, TYPE 1
- ⑦ EXISTING AGGREGATE SHOULDER TYPE "B"
- ⑧ PROPOSED HOT-MIX ASPHALT SURFACE REMOVAL, 2 1/4" (RAMPS)
- ⑨ PROPOSED HOT-MIX ASPHALT SURFACE REMOVAL, 4" (MAINLINE & INSIDE SHOULDER)
- ⑩ PROPOSED HOT-MIX ASPHALT SURFACE REMOVAL, 4" (OUTSIDE SHOULDER)
- ⑪ PROPOSED POLYMERIZED HOT-MIX ASPHALT BINDER COURSE, STONE MATRIX ASPHALT, N80, 2"
- ⑫ PROPOSED POLYMERIZED HOT-MIX ASPHALT SURFACE COURSE, STONE MATRIX ASPHALT, N80, 2"
- ⑬ PROPOSED HOT-MIX ASPHALT BINDER COURSE, IL-19, N70, 2 1/2 "
- ⑭ PROPOSED HOT-MIX ASPHALT SURFACE COURSE, MIX. "D", N70, 1 1/2"
- ⑮ PROPOSED SHOULDER RUMBLE STRIP
- ⑯ PROPOSED AGGREGATE WEDGE SHOULDER, TYPE "B"
- ⑰ PROPOSED GRADING AND SHAPING SHOULDER
- ⑱ PROPOSED POLYMERIZED LEVELING BINDER, IL-4.75, N50, 3/4"

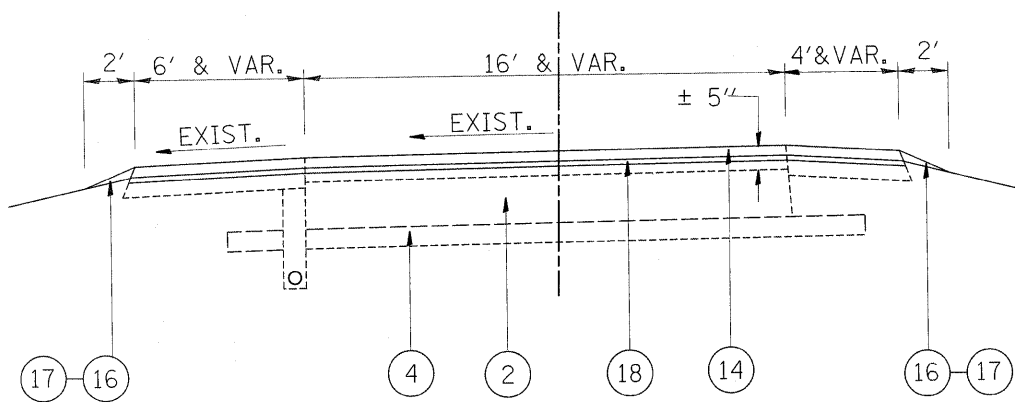

PROPOSED TYPICAL SECTION FOR RAMPS

NOTE:

1. CONTRACTOR SHALL PATCH BEFORE MILLING
2. THE SMA LIMIT ON THE RAMPS SHALL BE AT GORE LINE

FILE NAME =	USER NAME = obebawa	DESIGNED -	REVISED -	STATE OF ILLINOIS DEPARTMENT OF TRANSPORTATION	IL. ROUTE 55 TYPICAL SECTION FOR RAMPS	F.A.I. RTE.	SECTION	COUNTY	TOTAL SHEETS	SHEET NO.
c:\pw_work\PWIDOT\ABEBAWA\0169692\shd-11en.dgn	DRAWN -	REVISED -	55			99 (1&2) RS-12	WILL	110	6	
PLOT SCALE = 50.0000' / IN.	CHECKED -	REVISED -	CONTRACT NO. 60K04							
PLOT DATE = 2/11/2010	DATE -	REVISED -	ILLINOIS FED. AID PROJECT							
				SCALE:	SHEET NO. 1 OF 1 SHEETS	STA.	TO STA.			