

SECTION B-B

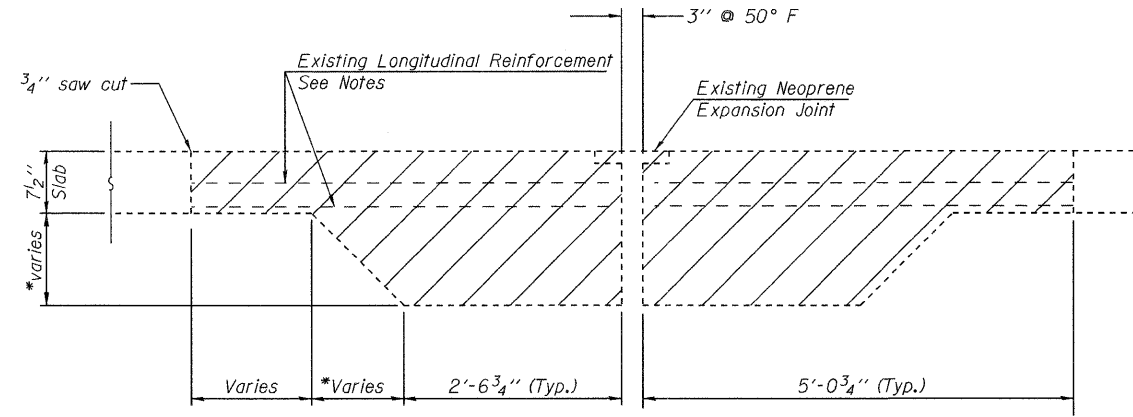

CONCRETE REMOVAL AT PIERS 4 & 8

(dimensions at right L's)

*1'-1" min. at low beam to
1'-5 1/8" max. at high beam

BILL OF MATERIAL
2 PIERS

Bar	No.	Size	Length	Shape
a(E)	88	#7	25'-3"	—
a3(E)	96	#6	4'-3"	—
d(E)	28	#5	5'-0"	┘
d1(E)	28	#5	3'-1"	┘
x(E)	168	#6	9'-5"	┘
Concrete Removal			Cu. Yd.	52.7
Concrete Superstructures			Cu. Yd.	56.3
Reinforcement Bars, Epoxy Coated			Pound	7770

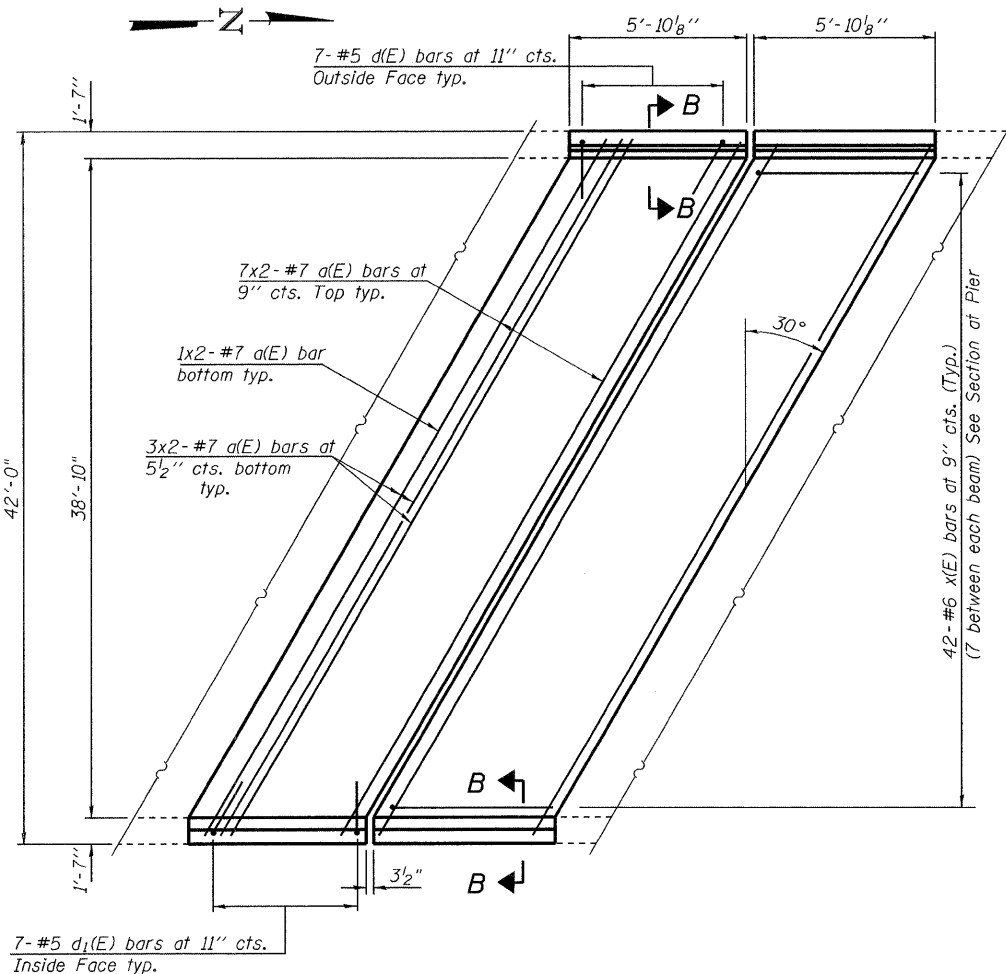

PLAN AT PIERS 4 & 8

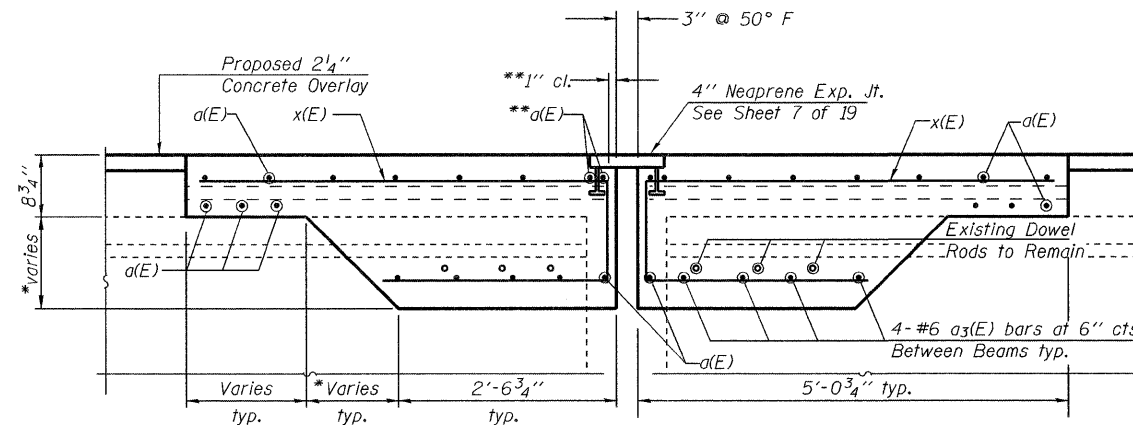

SECTION AT PIERS 4 & 8

(dimensions at right L's)

MIN. BAR LAP

#7 bars = 2'-9"

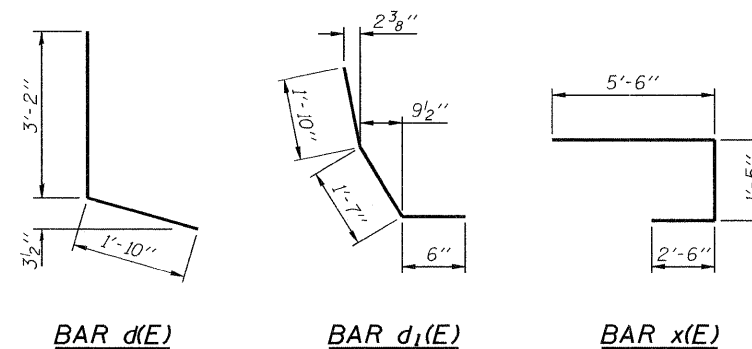

**Place a(E) bars in back of anchor bolt as shown if required to maintain 1" cl. (±0-1/8"). Anchor bolts should be tied to a(E) bars, typical each side of joint.

NOTES:

Existing longitudinal reinforcement and dowel rods extending into the removed areas shall be cleaned, straightened and incorporated into the new construction. Cost included with Concrete Removal.
Hatched areas indicate deck to be removed as Concrete Removal. Removal of existing neoprene joint is included with Concrete Removal.
The parapet within the limits of the deck to be removed is also to be removed as Concrete Removal.
Any longitudinal reinforcement bars extending into the New Construction that are damaged during concrete removal shall be replaced with an approved bar splicer or anchorage system. Cost included with Concrete Removal.

ILLINOIS DEPARTMENT OF TRANSPORTATION

SHEET TITLE	
EXPANSION JOINT DETAILS PIERS 4 & 8	
PROJECT	PROJECT NO.
I-55 NB OVER KANKAKEE RIVER	03095-16
FAI ROUTE 55, SECTION 88(B&B-1)BR	SCALE
WILL COUNTY	DATE
SN 099-0001	6/25/09
	DRAWN BY
	TFG/CFC
	CHECKED BY
	MCB
DRAWING NO.	
COOMBE-BLOXDORF P.C.	5
Engineers / Land Surveyors	
Springfield, Illinois	
Design Firm License No. 184-002703	OF 19 SHTS