

CONTRACT No. 63353

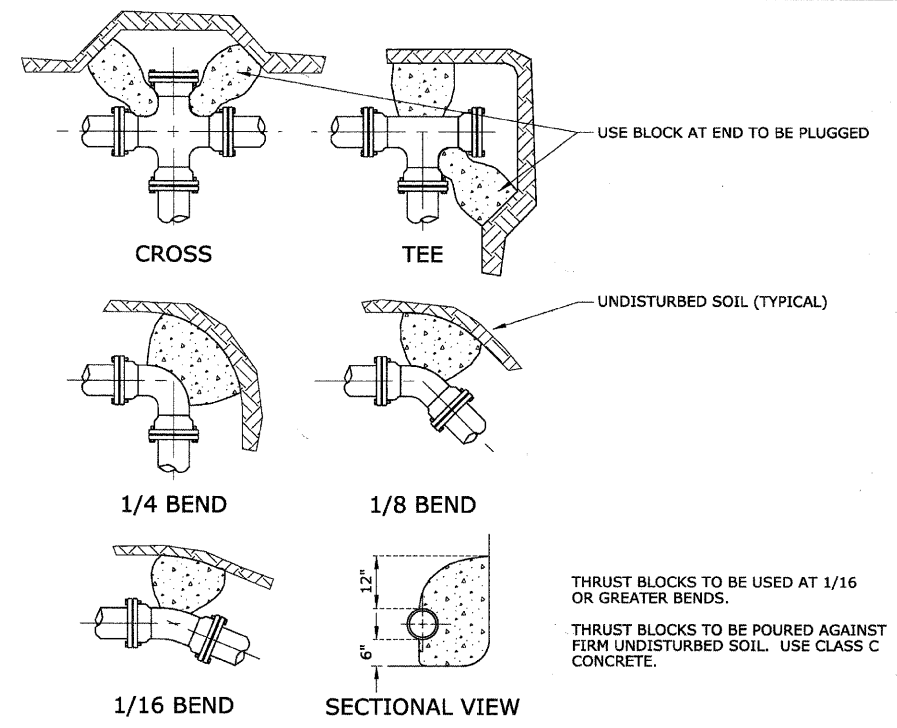

THRUST BLOCK DETAIL

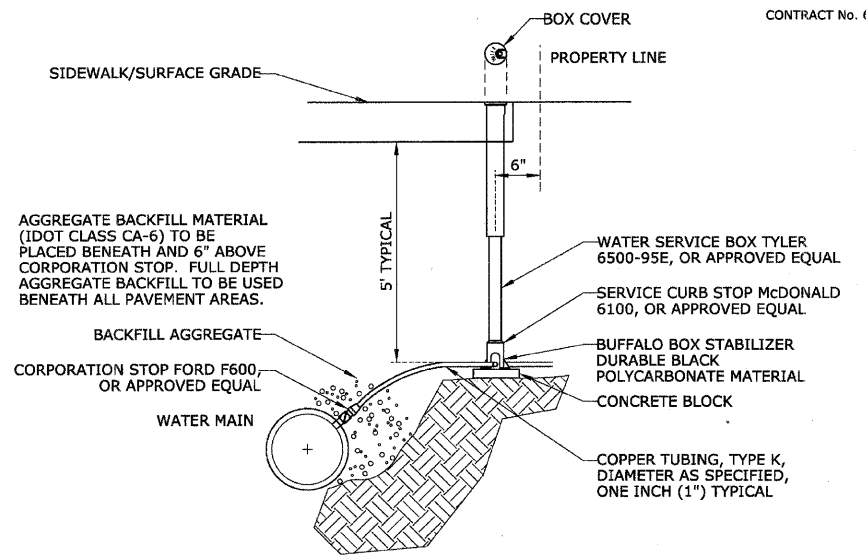

WATER SERVICE DETAIL

| | |
|---------------------|--|
| DATE | |
| BY | |
| PLANNED | |
| CHECKED | |
| BY | |
| NO. OF W.A. CHECKED | |
| NO. OF P.L. CHECKED | |
| NO. OF F.I. CHECKED | |
| NO. OF S.D. CHECKED | |
| NO. OF T.B. CHECKED | |
| NO. OF U.C. CHECKED | |
| NO. OF V.C. CHECKED | |
| NO. OF W.A. CHECKED | |
| NO. OF P.L. CHECKED | |
| NO. OF F.I. CHECKED | |
| NO. OF S.D. CHECKED | |
| NO. OF T.B. CHECKED | |
| NO. OF U.C. CHECKED | |
| NO. OF V.C. CHECKED | |

| | |
|---------------------|--|
| DATE | |
| BY | |
| PROPOSED | |
| CHECKED | |
| BY | |
| NO. OF W.A. CHECKED | |
| NO. OF P.L. CHECKED | |
| NO. OF F.I. CHECKED | |
| NO. OF S.D. CHECKED | |
| NO. OF T.B. CHECKED | |
| NO. OF U.C. CHECKED | |
| NO. OF V.C. CHECKED | |

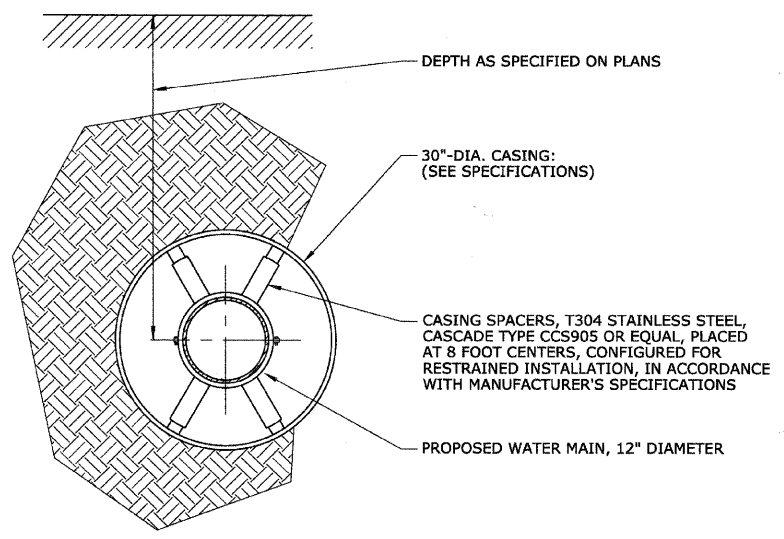

WATER MAIN IN STEEL CASING PIPE

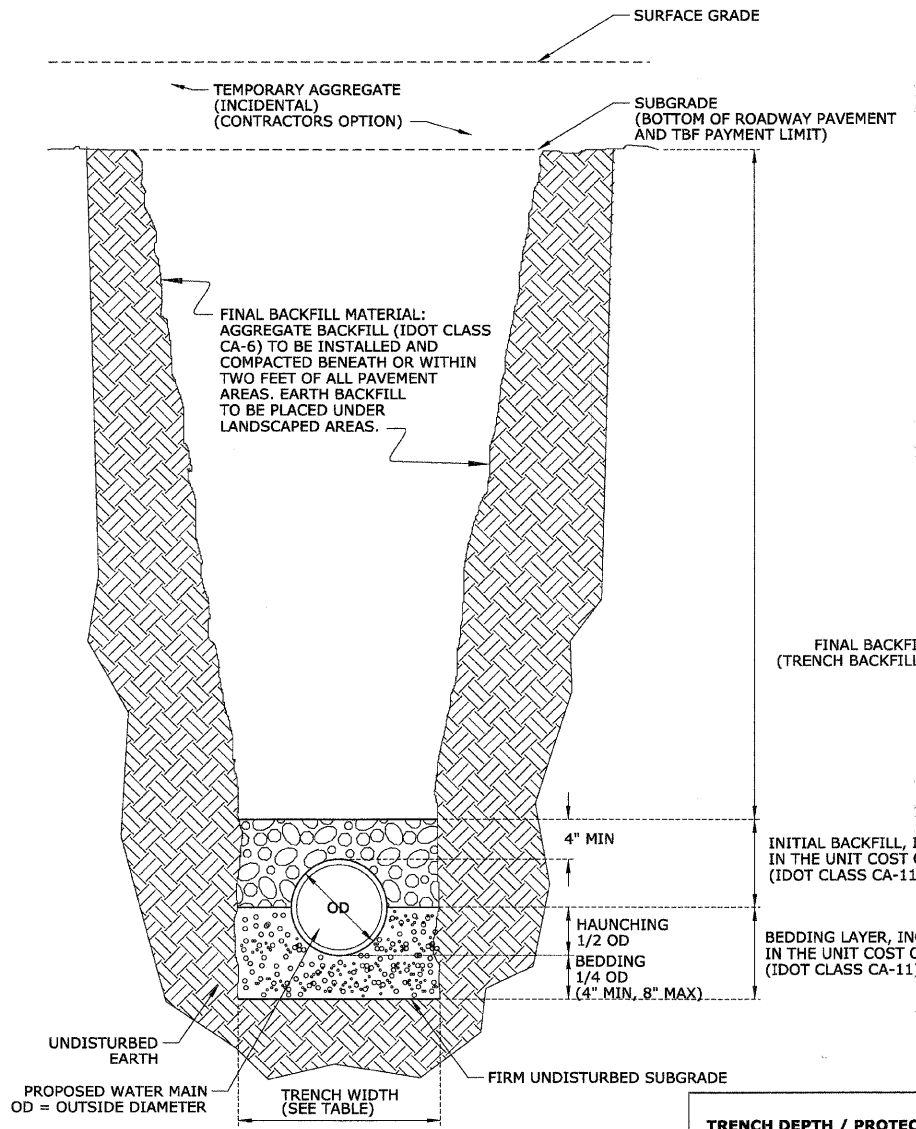

WATER TRENCH DETAIL

| TRENCH DEPTH / PROTECTION | MAXIMUM PAYMENT WIDTH OF TRENCH |
|-------------------------------|---------------------------------|
| 5 FT AND LESS, W/O PROTECTION | OD + 18" |
| 5 FT AND LESS, W/ PROTECTION | OD + 36" |
| GREATER THAN 5 FT | OD + 36" |

| REVISIONS | |
|-----------|------|
| NAME | DATE |
| | |
| | |
| | |
| | |
| | |
| | |
| | |
| | |
| | |
| | |

ILLINOIS DEPARTMENT OF TRANSPORTATION
**BLUFF AVENUE IMPROVEMENTS
 STAGE 3**
CONSTRUCTION DETAILS - SPECIAL
 SCALE: NTS
 DATE 11/30/2009
 DRAWN BY H&A
 CHECKED BY JRH