

**ROUNDBABOUT SIGNING
(FOR SPEEDS ≤ 40 M.P.H.)**

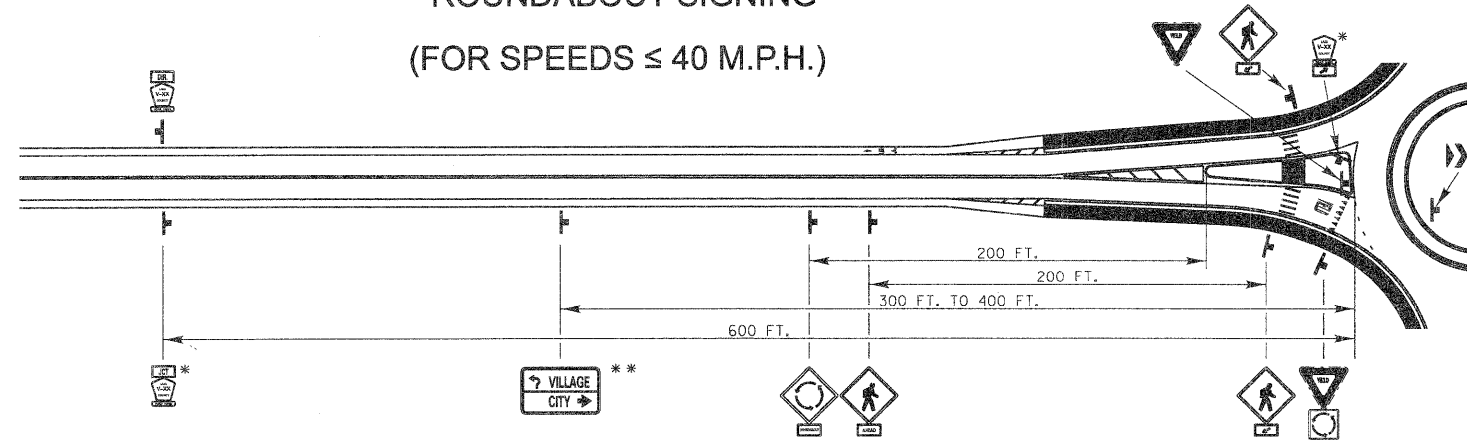

* FOR NON-MARKED ROUTES,
USE ADVANCE INTERSECTION
NAME SIGN WITH ROUNDBABOUT
SYMBOL

** OPTIONAL

**SPECIAL DETAIL FOR ROUNDBABOUTS
SIGNING and PAVEMENT MARKINGS**

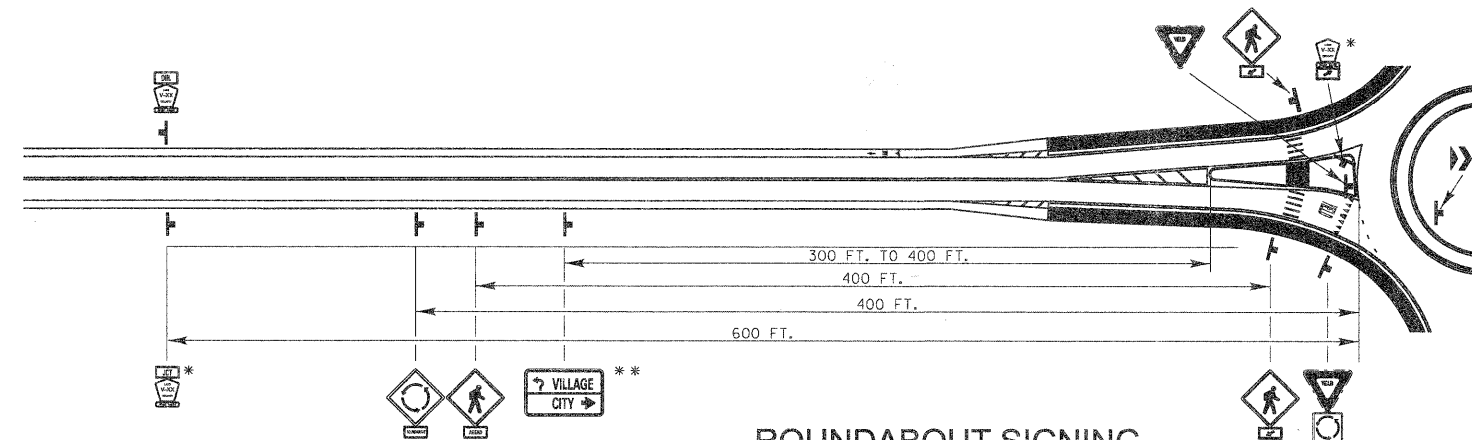

**ROUNDBABOUT SIGNING
(FOR SPEEDS ≥ 45 M.P.H.)**

**ROUNDBABOUT
PAVEMENT MARKINGS**

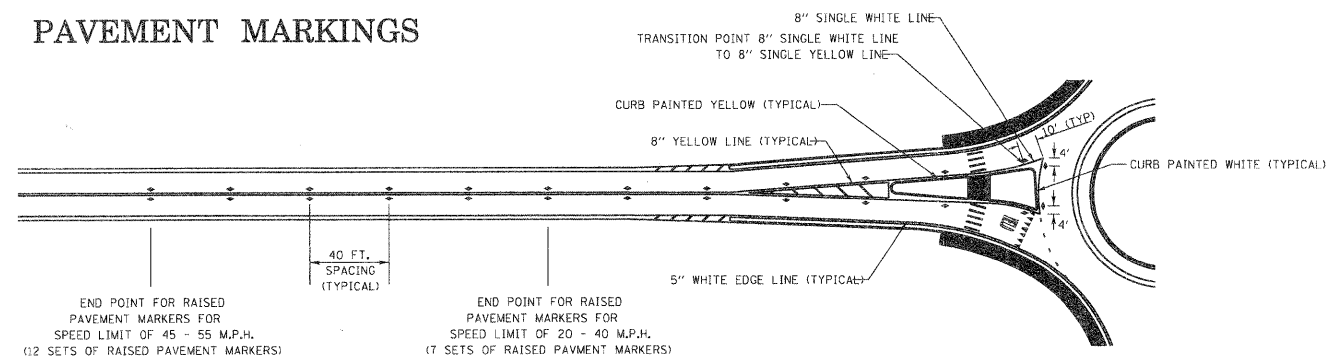

END POINT FOR RAISED
PAVEMENT MARKERS FOR
SPEED LIMIT OF 45 - 55 M.P.H.
(12 SETS OF RAISED PAVEMENT MARKERS)

40 FT.
SPACING
(TYPICAL)

END POINT FOR RAISED
PAVEMENT MARKERS FOR
SPEED LIMIT OF 20 - 40 M.P.H.
(7 SETS OF RAISED PAVEMENT MARKERS)

RAISED PAVEMENT MARKERS
45 - 55 mph = 12 Sets at 40' C-C
20 - 40 mph = 7 Sets at 40' C-C

REVISIONS	DATE	APPROVED BY: A. KHAWAJA
Added Curb Pav't Marking	10/20/08	DATE: July 1, 2008
Added Fig 2 - Distance Det	1/29/09	



**SPECIAL DETAIL for
ROUNDBABOUTS SIGNING
and PAVEMENT MARKINGS**
SHEET 2 OF 2

107804

NO.	DESCRIPTION	DATE	BY	SURVEYOR:
		/ /		DSGNR/LIAISON
		/ /		PLOTTED BY: 1/21/2010

FILE NAME: #FILES



TYPICAL SECTIONS

ROUTE	SECTION	SECTION NUMBER	SHEET	SHEETS
CH				

NO.	DESCRIPTION	DATE	BY	DESIGNED BY:	JRM
		/ /		CHECKED BY:	MPK/JLC
		/ /		DATE:	1/22/2010

FILE NAME:

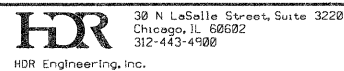

ROUTE	SECTION	SECTION NUMBER	SHEET	SHEETS
CH	136	04-00136-06-CH	103	107

6315