

ENCASEMENT DETAILS	
DROP M.H. LOCATION STA., OFFSET	
INV. "A"	
INLET PIPE	
INV. "B"	
INV. "C"	
A	
B	
"V" BAR LENGTH	
NO. OF "U" BARS	
REINF. BARS	
CLASS "S1" CONC. CUBIC METER (CU. YD.)	

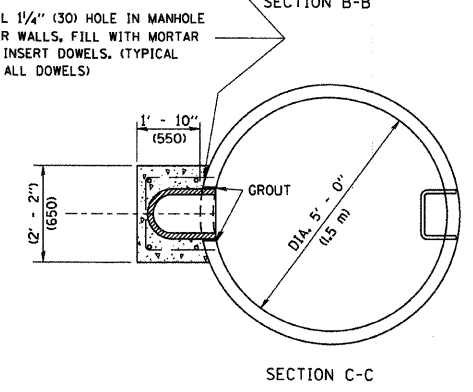
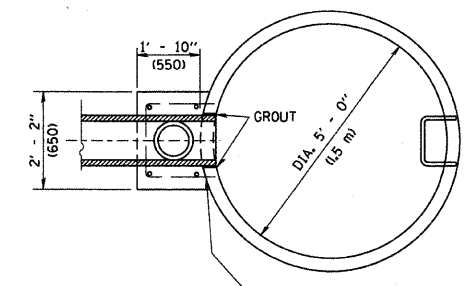
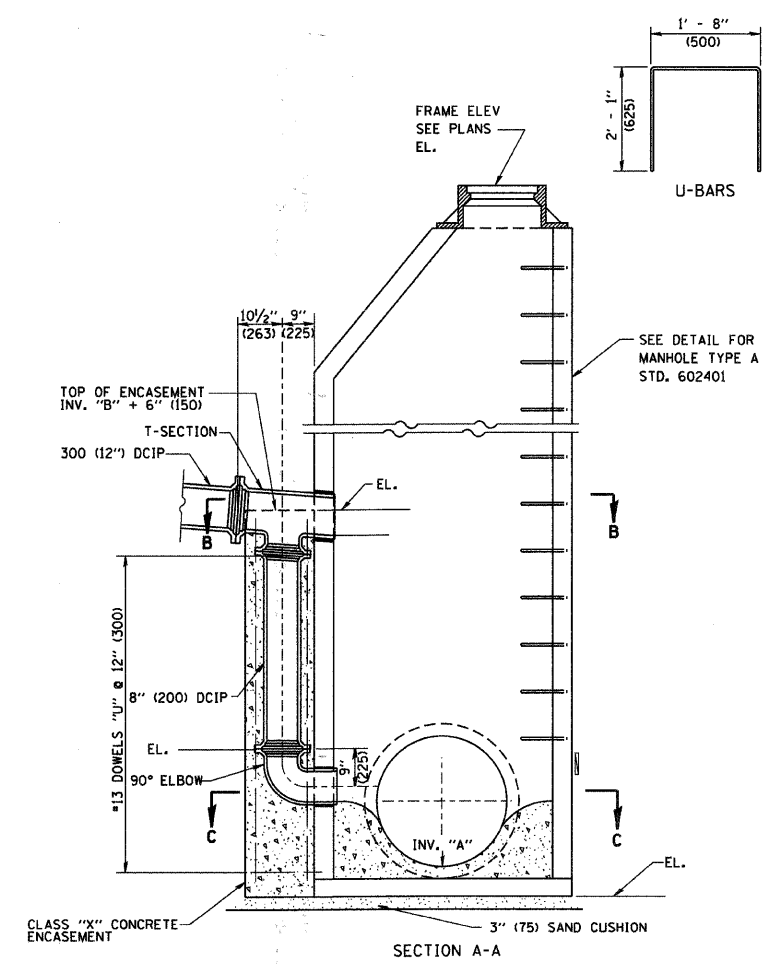

- TYPE A1-1 MANHOLE WITH 1 DROP AND DEPTH UP TO 10' (3 m)  
 TYPE A1-2 " " " " " FROM 10' TO 15' (3 m TO 1.5 m)  
 TYPE A1-3 " " " " " FROM 15' TO 20' (1.5 m TO 6 m)  
 TYPE A1-4 " " " " " OVER 20' (6 m)
- TYPE A2-1 MANHOLE WITH 2 DROPS AND DEPTH UP TO 10' (3 m)  
 TYPE A2-2 " " " " " FROM 10' TO 15' (3 m TO 1.5 m)  
 TYPE A2-3 " " " " " FROM 15' TO 20' (1.5 m TO 6 m)  
 TYPE A2-4 " " " " " OVER 20' (6 m)

ALL DIMENSIONS ARE IN INCHES (MILLIMETERS) UNLESS OTHERWISE SHOWN

FILE NAME = W:\diststd\22x34\bd16.dgn	USER NAME = gaglianobt	DESIGNED -	REVISED -
PLOT SCALE = 60,000 / IN.	CHECKED -	REVISOR -	REVISOR -
PLOT DATE = 1/4/2008	DATE = 10-18-02	REVISOR -	REVISOR -

STATE OF ILLINOIS  
DEPARTMENT OF TRANSPORTATION

DROP MANHOLE DETAILS			
SCALE: NONE	SHEET NO. 1 OF 1 SHEETS	STA.	TO STA.

F.A.P. RTE.	SECTION	COUNTY	TOTAL SHEETS	SHEET NO.
347	09-00248-00-RS	COOK	274	261
BD600-05 (BD-16)		CONTRACT NO.		
FED. ROAD DIST. NO. 1 ILLINOIS FED. AID PROJECT				