

STATE OF ILLINOIS
DEPARTMENT OF TRANSPORTATION

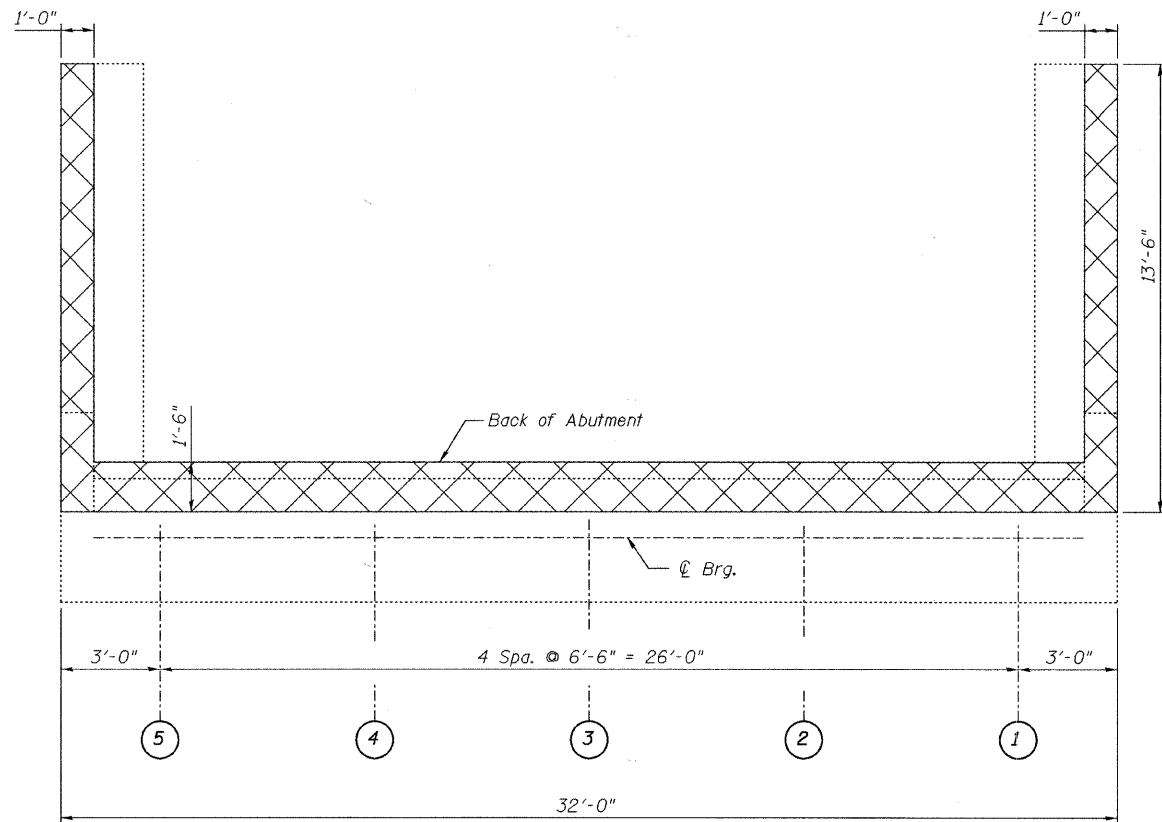

PLAN

(N. Abut. shown, S. Abut. opposite hand)

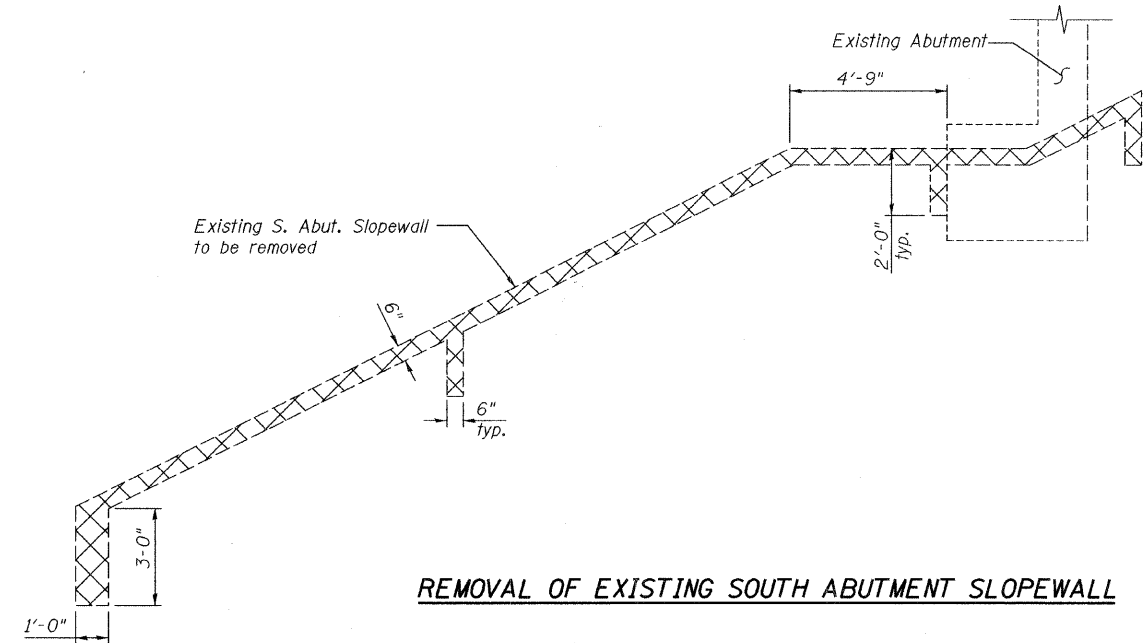

REMOVAL OF EXISTING SOUTH ABUTMENT SLOPEWALL

BILL OF MATERIAL

ITEM	UNIT	TOTAL
Concrete Removal	Cu. Yd.	39.9
Slope Wall Removal	Sq. Yd.	375
Approach Slab Removal	Sq. Yd.	240

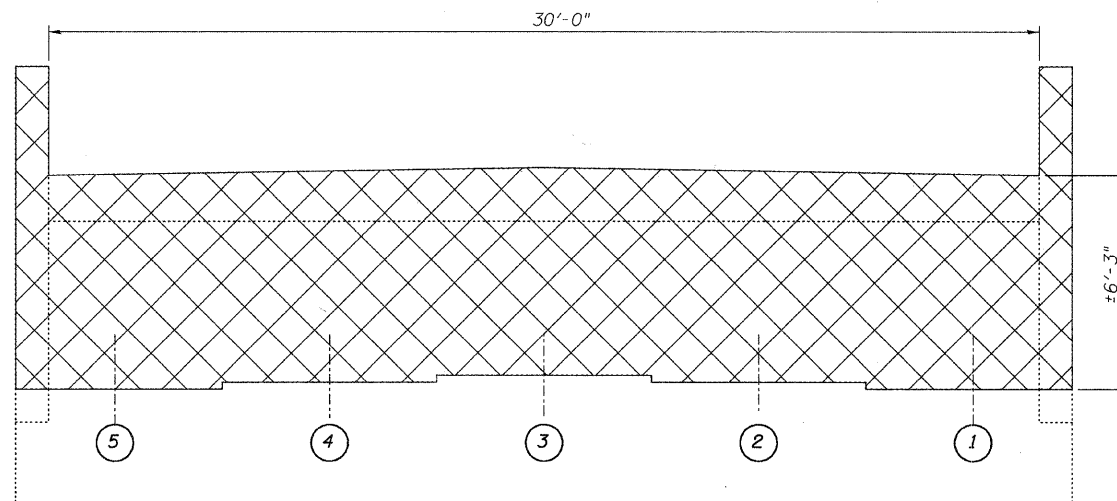

ELEVATION

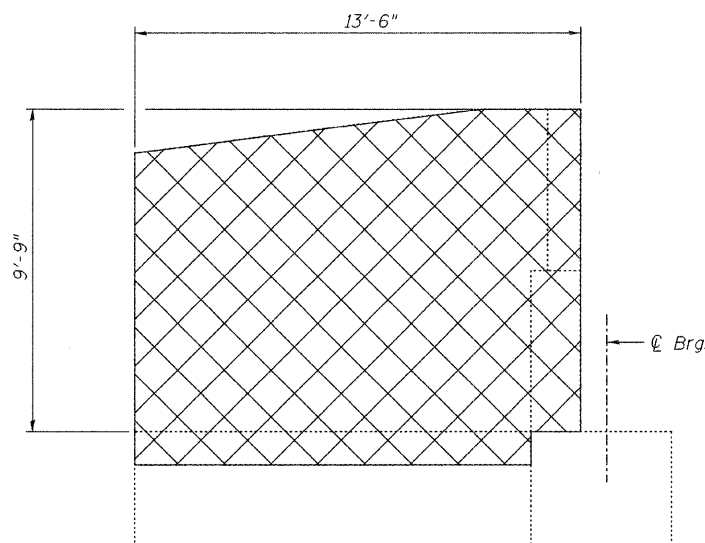

WINGWALL ELEVATION

(4 thus)

indicates Concrete Removal

NOTES:

1. Approach slab to be removed, see special provision for "Approach Slab Removal."
2. Existing reinforcement bars extending into concrete removal areas shall be cleaned, straightened and incorporated into new concrete in accordance with IDOT Standard Specifications Article 501.03. Cost included with Concrete Removal.
3. Any reinforcement bars that are damaged during concrete removal operations shall be repaired or replaced using an approved bar splicer or anchorage system in accordance with IDOT Standard Specifications Article 501.03. Cost included with Concrete Removal.

DESIGNED -	JLS
CHECKED -	MRB
DRAWN -	VH/MB
CHECKED -	KWS

**CONCRETE REMOVAL
STRUCTURE NO. 099-3298**

SHEET NO. S4 S47 SHEETS	F.A.U. RTE.	SECTION	COUNTY	TOTAL SHEETS	SHEET NO.
	341	04-00090-07-BR	WILL	57	12
FED. ROAD DIST. NO.			ILLINOIS	CONTRACT NO. 63442	
			FED. AID PROJECT		

benesch

alfred benesch & company
Engineers • Surveyors • Planners
202 North Michigan Avenue, Suite 2400
Chicago, Illinois 60601
312-565-0450 Job No. 3808.02