

STATE OF ILLINOIS
DEPARTMENT OF TRANSPORTATION

** Other sections meeting the minimum section modulus shown may be used, subject to approval by the Bureau of Bridges and Structures. The maximum girder depth provided shall be 24".

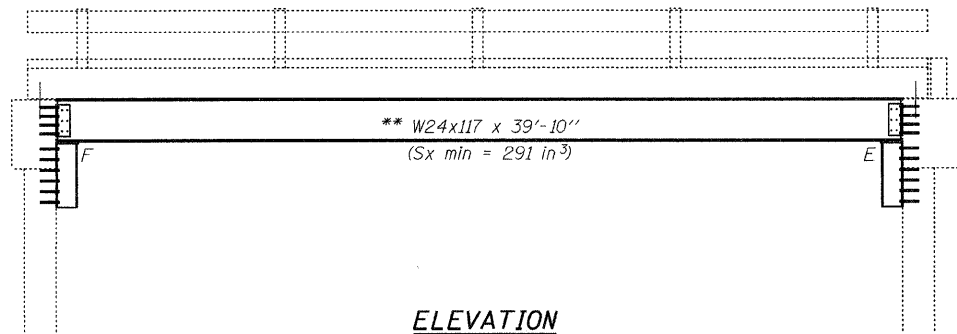

ELEVATION

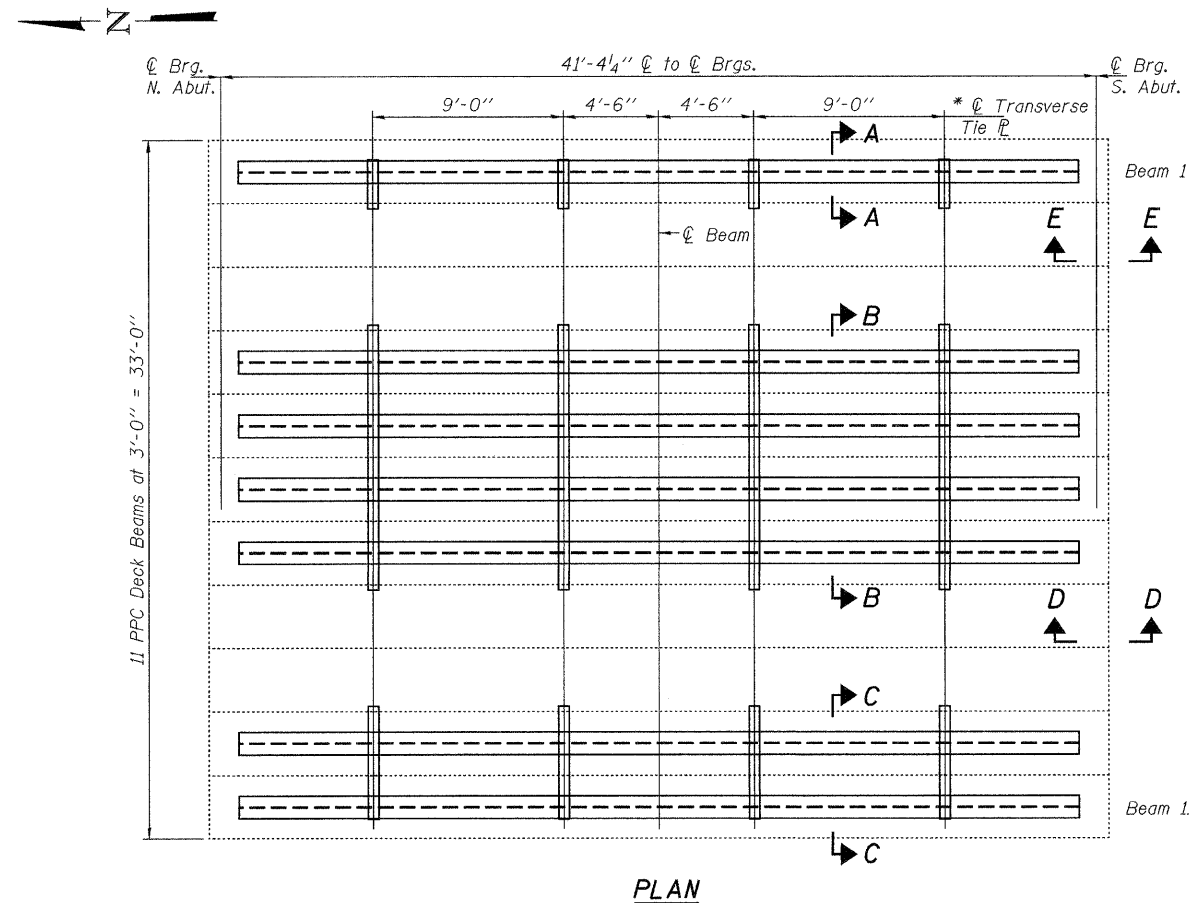

PLAN

GENERAL NOTES

All structural steel shall conform to AASHTO Classification M-270 Gr. 36, unless otherwise noted.

Plan dimensions and details relative to existing plans are subject to nominal construction variations. The Contractor shall field verify existing dimensions and details affecting new construction and make necessary approved adjustments prior to construction or ordering of materials. Such variations shall not be cause for additional compensation for a change in scope of the work, however, the Contractor will be paid for the quantity actually furnished at the unit price bid for the work.

See Section 584 of the Standard Specifications for Epoxy Grouting of Threaded Rods. The cost of epoxy grouting threaded rods shall be included with Furnishing and Erecting Structural Steel.

The Contractor has the option of using used steel. See special provisions.

The contractor is advised that the existing PPC Deck Beams are in a deteriorated condition with reduced load carrying capacity. It is the contractors responsibility to account for the condition of the beams when developing construction procedures.

If the contractor's procedure for placement of beams involves placement of cranes or other heavy equipment on the bridge, a detailed procedure shall be submitted to the Engineer for approval. The procedure shall include calculations, prepared and sealed by an Illinois Licensed Structural Engineer, verifying that the equipment and procedure used will not overstress the existing beams. To distribute load to multiple beams and protect the existing surface, in all cases a double layer mat of heavy timbers shall be used at all times under crane tracks or wheels and any outriggers in the down position. If necessary, shims shall be used under the crane mat to ensure uniform contact with the underlying beams.

No in-stream work will be permitted due to endangered species.

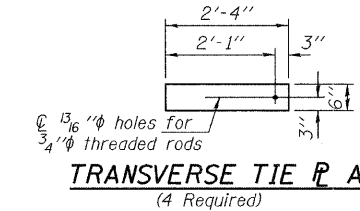

TRANSVERSE TIE PLATE A
(4 Required)

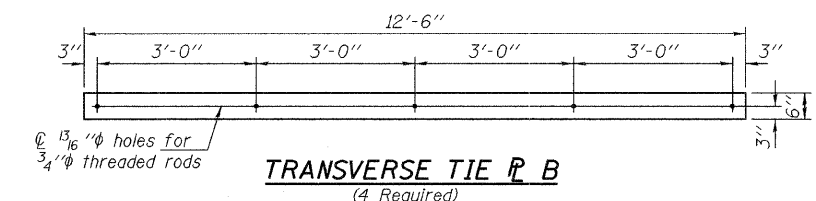

TRANSVERSE TIE PLATE B
(4 Required)

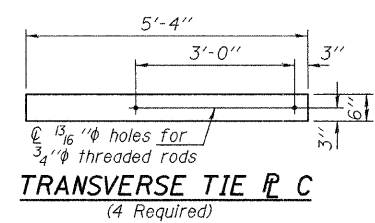

TRANSVERSE TIE PLATE C
(4 Required)

* See sheet 2 of 2 for transverse tie plate designations.

TOTAL BILL OF MATERIAL

ITEM	UNIT	QUANTITY
Furnishing and Erecting Structural Steel	Pound	36710

PLAN AND ELEVATION
IL 172 OVER COUNTY DITCH NO 1
SN 098-0044

DESIGNED *Vitor H. Veliz*
CHECKED *Rain Bali*
DRAWN *baliva*
CHECKED *VHV*

FEBRUARY 16, 2010
EXAMINED *R. Carl Thompson*
PASSED *Ralph E. Robinson*



EXPIRES 11-30-2010

SHEET NO. 1	F.A.S. RTE.	SECTION	COUNTY	TOTAL SHEETS	SHEET NO.
2 SHEETS	200	(102BR-1)M-2 & (141BR)M	WHITESIDE	7	6
FED. ROAD DIST. NO.			ILLINOIS FED. AID PROJECT		
			CONTRACT NO. 64G10		