

ROUTE NO.	SECTION	COUNTY	TOTAL SHEETS	SHEET NO.
F.A.S. 317	36-BR	IROQUOIS	21	14
FED. ROAD DIST. NO. 7	ILLINOIS	FED. AID PROJECT-		

SHEET NO. 6
10 SHEETS

CONTRACT NO. 66171

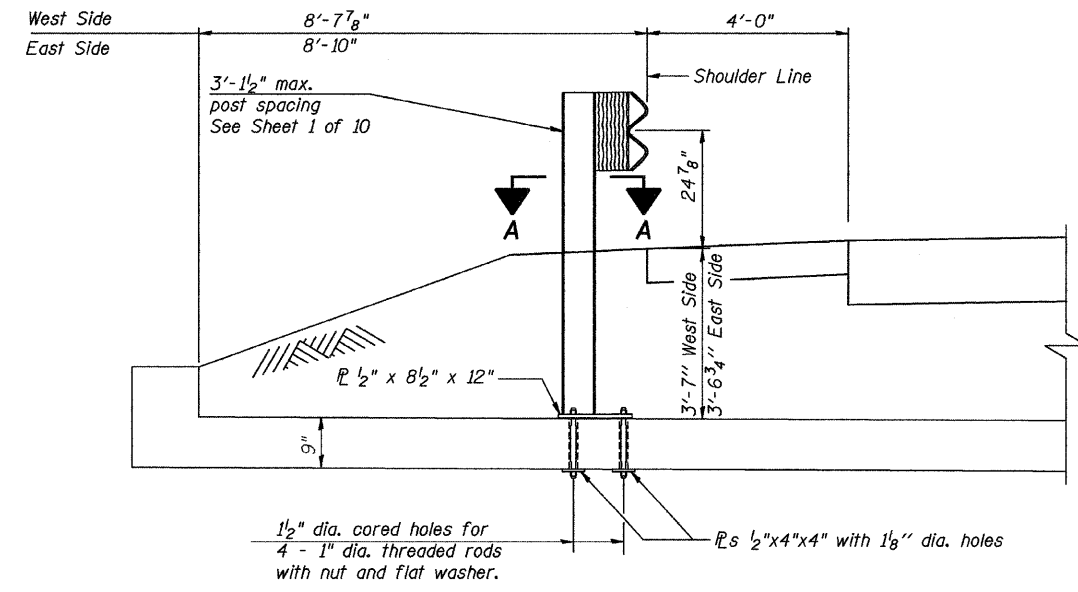

**STEEL PLATE BEAM GUARDRAIL.
ATTACHED TO STRUCTURES**

Lt. & Rt. Sta. 1250+64.00 to 1251+01.50 = 37.5 feet
 Lt. & Rt. Sta. 1250+68.50 to 1251+06.00 = 37.5 feet
 75 feet

GUARDRAIL ANCHORAGE DETAIL

(For Guardrail Details See Std. 630101 - Case IV)

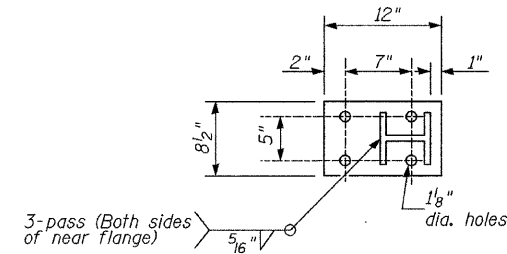

SECTION A-A

NOTES

Railing shall be according to Section 630 of the Standard Specifications except as noted, and will be paid for at the contract unit price per foot for STEEL PLATE BEAM GUARDRAIL, ATTACHED TO STRUCTURES.

Contractor shall space a & a_1 bars to miss cored holes.

All bolts, nuts and plates shall be galvanized. See Article 1006.25 of Standard Specifications.

98-767038-0015/culvertdetails.dgn

DESIGNED	M.E.B.
CHECKED	R.K.M.
DRAWN	P.W.S.
CHECKED	M.E.B.

CULVERT DETAILS
F.A.S. ROUTE 317 (US 45) OVER
TRIBUTARY TO SPRING CREEK
SECTION 36-BR
IROQUOIS COUNTY
STA. 1250+85.00
STRUCTURE NO. 038-2015