

**PARAPET TO CURB TRANSITION  
PILE BENT ABUTMENT**

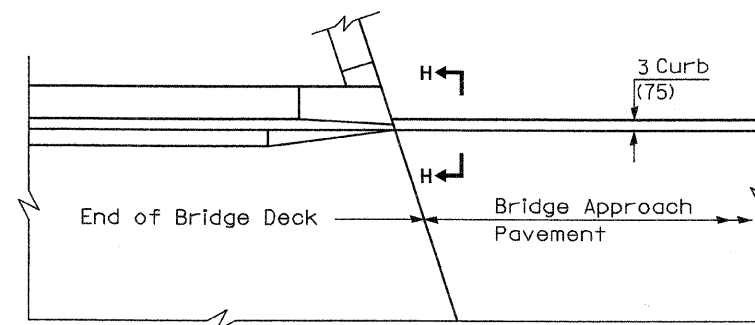

**PARAPET TO CURB TRANSITION  
INTEGRAL ABUTMENT**

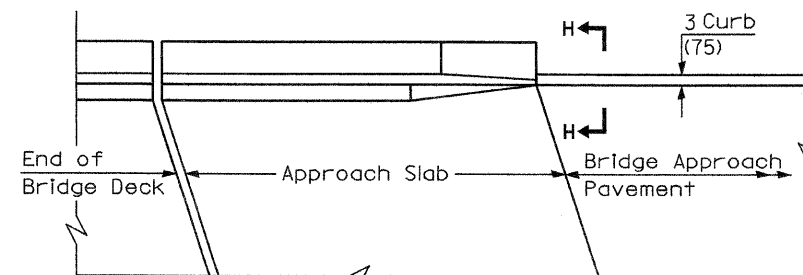

**PARAPET TO CURB TRANSITION  
VAULTED ABUTMENT**

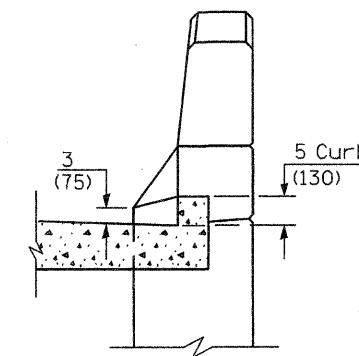

**SECTION I - I**

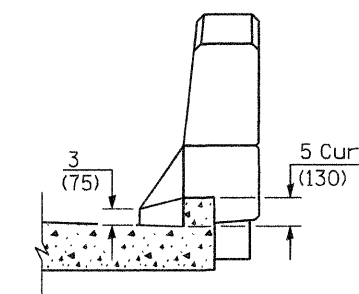

**SECTION H - H**

**BRIDGE APPROACH PAVEMENT**

(Sheet 4 of 4)

ROUTE	SECTION	COUNTY	TOTAL SHEETS	SHEET NO.
F.A.P. 68	(3)BR-1	LASALLE	44	33D

CONTRACT NO. 66619

Illinois Department of Transportation

APPROVED January 1, 2008  
*Walsh E. Anderson*  
 ENGINEER OF BRIDGES AND STRUCTURES

ISSUED  
 1/6-1-1 GENST

APPROVED January 1, 2008  
*Ken E. Han*  
 ENGINEER OF DESIGN AND ENVIRONMENT