

STATE OF ILLINOIS
DEPARTMENT OF TRANSPORTATION

ROUTE NO.	SECTION	COUNTY	SHEETS	SHEET NO.	SHEET NO. 2
FAI 80	50 - 8HBR	LASALLE	43	63	26 SHEETS
FED. ROAD DIST. NO. 7	ILLINOIS	FED. AID PROJECT			

Contract # 66645

GENERAL NOTES

- Fasteners shall be AASHTO M154 Type 1, mechanically galvanized bolts. Bolts $\frac{7}{8}$ " ϕ , open holes $\frac{15}{16}$ " ϕ , unless otherwise noted.
- Calculated weight of Structural Steel (M270, Grade 50) = 426,890 lbs.
Calculated weight of Structural Steel (M270, Grade 36) = 45,810 lbs.
- No field welding is permitted except as specified in the contract documents.
- Reinforcement bars shall conform to the requirements of ASTM A 706 Gr 60. See Special Provisions.
- Reinforcement bars designated (E) shall be epoxy coated.
- If the Contractor elects to use cantilever forming brackets on the exterior girders, the brackets shall be placed at the same locations as required for the hardwood blocks in Article 503.06(b) of the Standard Specifications. If additional cantilever forming brackets are required, hardwood blocking shall be wedged between the exterior and the first interior girder at each of these additional bracket locations.
- Bearing seat surfaces shall be constructed or adjusted to the designated elevations within a tolerance of $\frac{1}{8}$ in. (0.01 ft.). Adjustment shall be made either by grinding the surface or by shimming the bearings.
- Concrete Sealer shall be applied to the exposed surface areas of the Pier.
- The existing structural steel coating contains lead. The Contractor shall take appropriate precautions to deal with the presence of lead on this project.
- The Inorganic Zinc Rich Primer / Acrylic / Acrylic Paint System shall be used for shop and field painting of new structural steel except where otherwise noted. The color of the final finish coat for all interior steel surfaces shall be gray, Munsell No 5B 7/1. The color of the final coat for the exterior and the bottom flange of the fascia girders shall be Interstate Green, Munsell No 7.5G 4/8. See Special Provisions for "Cleaning and Painting New Metal Structures".
- The embankment configuration shown shall be the minimum that must be placed and compacted prior to construction of the abutments.
- The Contractor shall drive test piles to 110% of the nominal required bearing specified in production locations at substructures specified or approved by the Engineer before ordering the remainder of piles.
- The Contractor shall connect the first sheet to the existing abutment wall to ensure stability of sheets driven to the top of the existing footing. This connection shall be reviewed and accepted by the Engineer and included in the cost for Temporary Sheet Piling.
- No precoring is required for the piles at the abutments.
- Slipforming of parapets shall not be allowed.

INDEX OF SHEETS

- S-1 General Plan
- S-2 General Notes, Index of Sheets & Total Bill of Material
- S-3 Stage Construction Details
- S-4 Temporary Bridge Rail for Stage Construction
- S-5 Temporary Concrete Barrier for Stage Construction
- S-6 Top of Deck Elevations (1 of 3)
- S-7 Top of Deck Elevations (2 of 3)
- S-8 Top of Deck Elevations (3 of 3)
- S-9 Top of South Approach Slab Elevations
- S-10 Top of North Approach Slab Elevations
- S-11 Deck Plan
- S-12 Superstructure Details (1 of 2)
- S-13 Superstructure Details (2 of 2)
- S-14 Bridge Approach Slab Details (1 of 2)
- S-15 Bridge Approach Slab Details (2 of 2)
- S-16 Framing Plan
- S-17 Framing Details
- S-18 Bearing Details
- S-19 South Abutment
- S-20 North Abutment
- S-21 Pier
- S-22 Bar Splicer Assembly Details
- S-23 Steel Pile Details
- S-24 Boring Logs (1 of 3)
- S-25 Boring Logs (2 of 3)
- S-26 Boring Logs (3 of 3)

TOTAL BILL OF MATERIAL

ITEM	UNIT	SUPER	SUB	TOTAL
Porous Granular Embankment (Special)	Cu yd		280	280
Removal of Existing Structures	Each			1
Protective Shield	Sq yd	554		554
Structure Excavation	Cu yd		587	587
Concrete Structures	Cu yd		260.3	260.3
Concrete Superstructure	Cu yd	685.9		685.9
Bridge Deck Grooving	Sq yd	1913		1913
Concrete Encasement	Cu yd		10.4	10.4
Protective Coat	Sq yd	2179		2179
Furnishing and Erecting Structural Steel	L Sum	1		1
Stud Shear Connectors	Each	3840		3840
Reinforcement Bars, Epoxy Coated	Pound	150,700	38,280	188,980
Bar Splicers	Each	955	159	1114
Steel Railing (Temporary)	Foot	237		237
Slope Wall 4 Inch	Sq yd		645	645
Furnishing Steel Piles HP10x42	Foot		2407	2407
Driving Piles	Foot		2407	2407
Test Pile Steel HP10x42	Each		3	3
Temporary Sheet Piling	Sq ft		909	909
Name Plates	Each		1	1
Anchor Bolts, 1"	Each		40	40
Anchor Bolts, 1 1/2"	Each		20	20
Concrete Sealer	Sq ft		2394	2394
Geocomposite Wall Drain	Sq yd		152	152
Pipe Underdrains for Structures 4"	Foot		184	184

All drainage system components shall extend to 2'-0" from the end of each wingwall except an outlet pipe shall extend until intersecting with the side slopes. The pipes shall drain into concrete headwalls. (See Article 601.05 of the Standard Specifications and Highway Standard 601101)

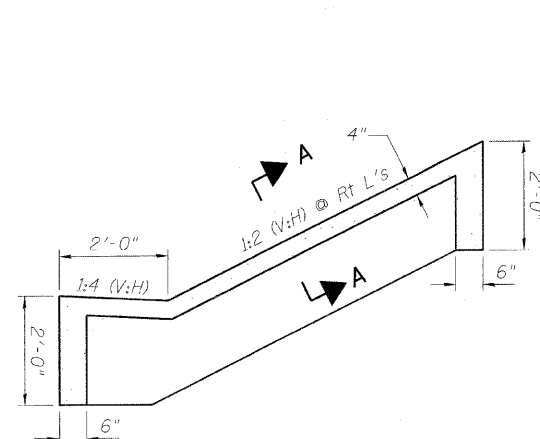

SECTION THRU SLOPEWALL

Slope wall shall be reinforced with welded wire fabric, 6 in. x 6 in. - W4.0 x W4.0, weighing 58 lbs. per 100 sq. ft.

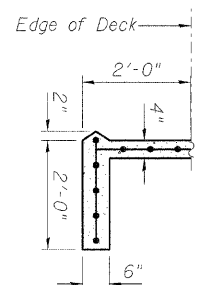

SECTION A-A

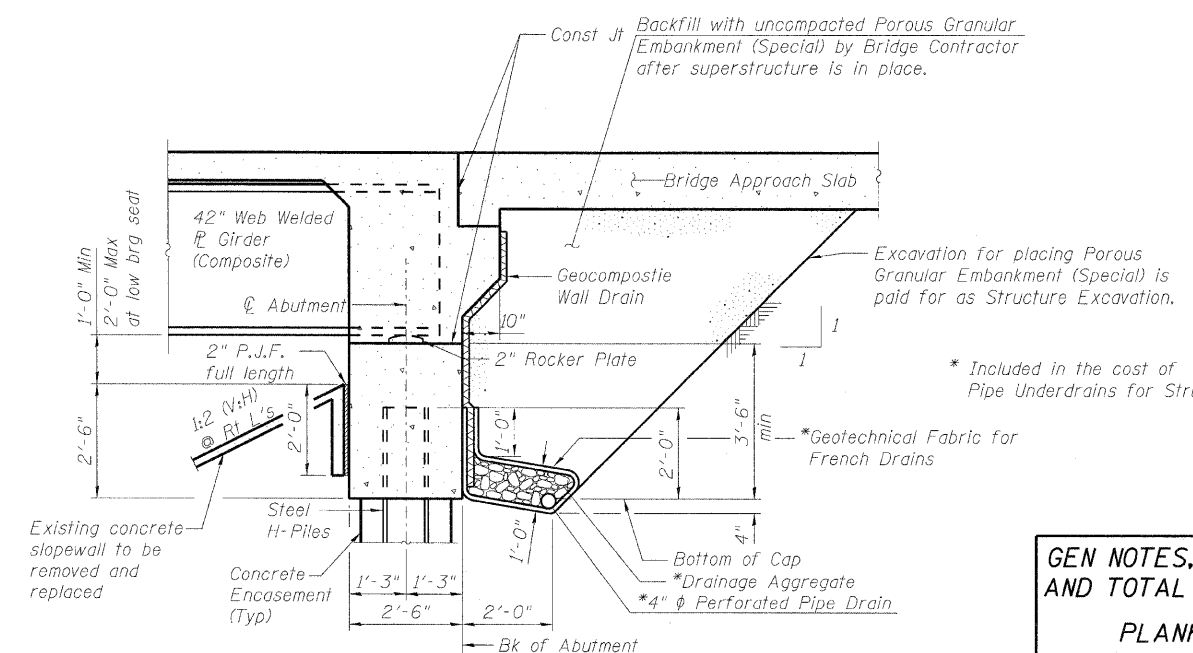

SECTION THRU INTEGRAL ABUTMENT

(Dimensions at Right L's)

GEN NOTES, INDEX OF SHEETS AND TOTAL BILL OF MATERIAL

PLANK ROAD OVER
FAI ROUTE 80 (I-80)
SECTION 50-8HBR
LASALLE COUNTY
STATION 3886+74.90
STRUCTURE NO. 050-0249

DESIGNED	- BHS
CHECKED	- BPS
DRAWN	- RRG
CHECKED	- GSP