

PROPOSED TYPICAL SECTION WITH SUPERELEVATION

#3

STA. 47+64 TO 57+47

*NOTE - TRANSITION FROM 1 1/2" TO 3/4" MILLING FROM STA. 56+87 TO 57+47

LEGEND

EXISTING

- ① P.C.C. PAVEMENT (9"-6"-9")
- ② BITUMINOUS OVERLAY, 2 1/2"±
- ③ BITUMINOUS OVERLAY, 3 3/4"±
- ④ BITUMINOUS OVERLAY, 2 1/4"±
- ⑤ P.C.C. BASE COURSE, 8"
- ⑥ SUBBASE GRANULAR, 12"
- ⑦ CURB & GUTTER (B-6.12)
- ⑧ HMA SHOULDERS, 6"±
- ⑨ HMA SHOULDERS, 8"±
- ⑩ AGGREGATE SHOULDERS, 6"±
- ⑪ BITUMINOUS OVERLAY, 10"±
- ⑫ BITUMINOUS OVERLAY, 6"±
- ⑬ BITUMINOUS OVERLAY, 4"±
- ⑭ BITUMINOUS BASE COURSE, 12"±
- ⑮ GRANULAR EMBANKMENT, 0" TO 15"±

PROPOSED

- ⑯ HMA SURFACE REMOVAL, 3/4"
- ⑰ HMA SURFACE REMOVAL, 1 1/2"
- ⑱ HMA SURFACE REMOVAL, 2"
- ⑲ POLY LEVEL BINDER, IL 4.75, N50, 3/4"
- ⑳ POLY HMA SURF. CSE. MIX "E", N70, 1 1/2"
- ㉑ POLY HMA SURF. CSE. MIX "D", N50, 1 1/2"
- ㉒ HMA SHOULDERS, 1 1/2"
- ㉓ AGGREGATE SHOULDERS, TYPE B
- ㉔ EPOXY PAVEMENT MARKING
- ㉕ URETHANE EPOXY PAVEMENT MARKING
- ㉖ PREFORMED PLASTIC PAVEMENT MARKING, TYPE B

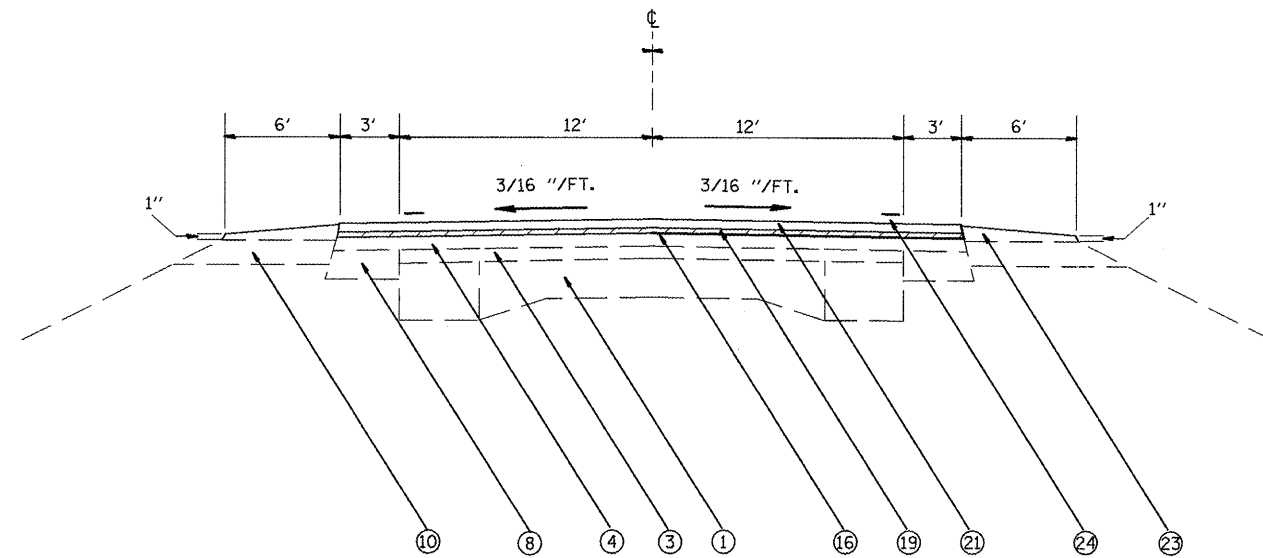

PROPOSED TYPICAL SECTION

#4

STA. 57+47 TO 246+32
STA. 264+60 TO 402+16

FILE NAME = D468625-shr-typical.dgn	USER NAME = dsetzsm	DESIGNED -	REVISED -	STATE OF ILLINOIS DEPARTMENT OF TRANSPORTATION	TYPICAL SECTIONS	F.A.P. RTE.	SECTION	COUNTY	TOTAL SHEETS	SHEET NO.
	PLOT SCALE = 100.0000 / IN.	CHECKED -	REVISED -			673	1104N,RS-5,106RS-2+107RS-6	WOODFORD	63	9
PLOT DATE = 1/28/2010	DATE -	REVISED -	REVISED -	SCALE:	SHEET NO. OF SHEETS STA. TO STA.	CONTRACT NO. 68625 ILLINOIS FED. AID PROJECT				