

STATE OF ILLINOIS
DEPARTMENT OF TRANSPORTATION
DIVISION OF HIGHWAYS

**PROPOSED
HIGHWAY PLANS**

FAP ROUTE 673
SECTION 101RS-3; 102RS-4; 103RS-4; 104 ETC
PROJECT ACF-0673(026)
PAVEMENT PRESERVATION POLICY
TAZEWELL & WOODFORD COUNTIES

F.A.P. RTE.	SECTION	COUNTY	TOTAL SHEETS	SHEET NO.
673	**	TAZE/	60	1
ILLINOIS			CONTRACT NO. 68920	

** 101RS-3; 102RS-4; 103RS-4; 104RS-7

D94-087-09

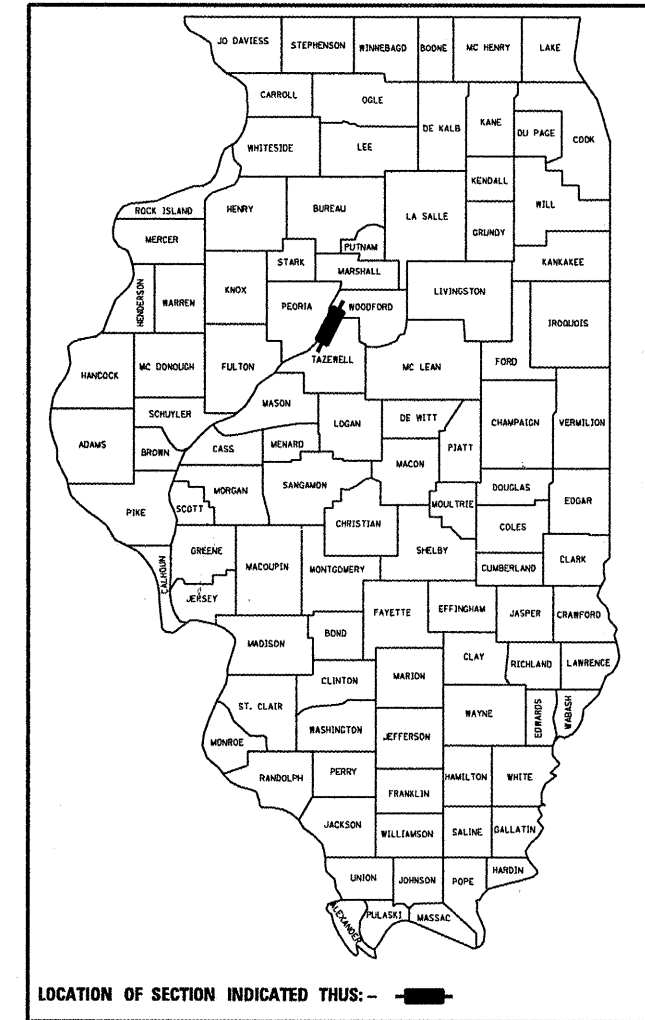

INDEX OF SHEETS
SEE PAGE 2

HIGHWAY STANDARDS

420001-07	701701-06
420701-02	701901-01
442101-07	781001-03
631011-06	814006-02
631031-08	857001-01
701101-02	873001-02
701411-06	880006-01
701421-02	886001-01
701423-03	886006-01

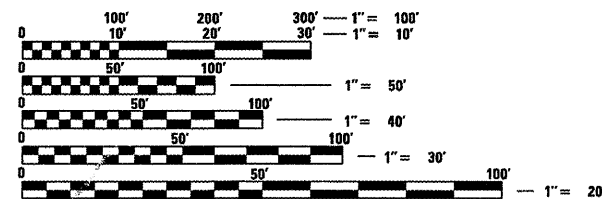

FULL SIZE PLANS HAVE BEEN PREPARED USING STANDARD ENGINEERING SCALES. REDUCED SIZED PLANS WILL NOT CONFORM TO STANDARD SCALES. IN MAKING MEASUREMENTS ON REDUCED PLANS, THE ABOVE SCALES MAY BE USED.

J.U.L.I.E.
JOINT UTILITY LOCATION INFORMATION FOR EXCAVATION
1-800-892-0123
OR 811

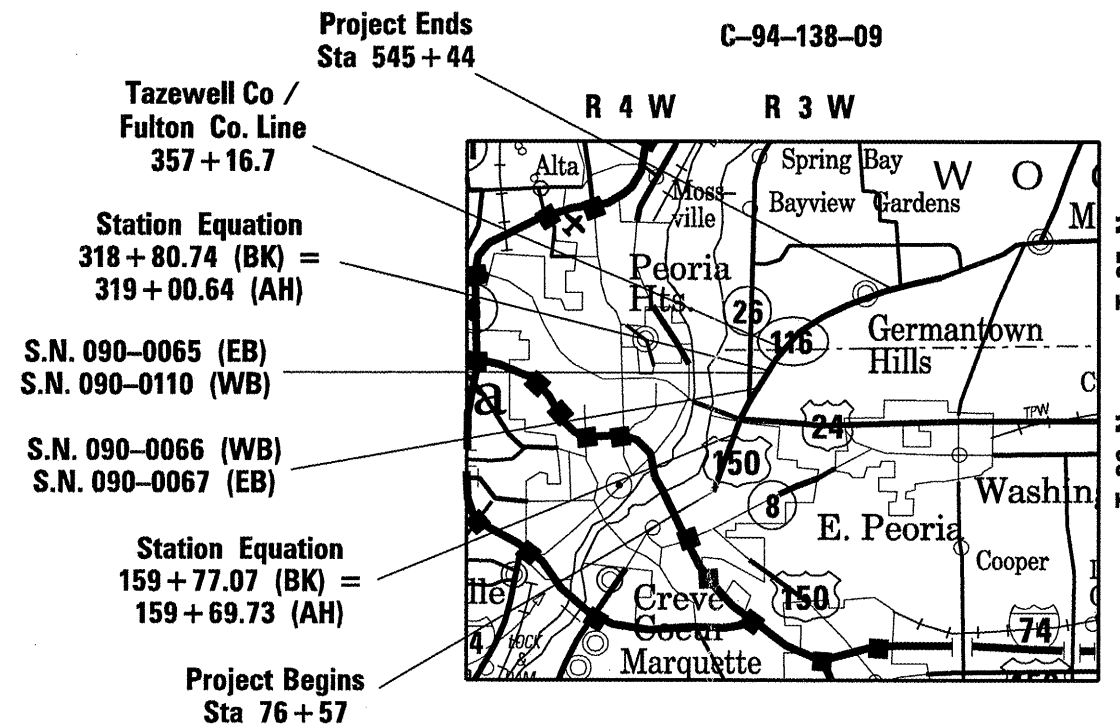

JOB DESCRIPTION

This project consists of 3/4" hot-mix asphalt surface removal, 1 1/2" hot-mix asphalt surface removal, 3/4" leveling binder, 1 1/2" hot-mix asphalt surface course, guardrail removal and replacement, patching, signal upgrades, detector loops, fiber optic cable installation, bridge hydroscarification, latex concrete overlay, and joint removal and replacement.

PROJECT ENGINEER: CHRIS MAUSHARD 309-671-3453
DESIGN BY: MICHAEL HUDELSON 309-671-3477

CONTRACT NO. 68920

GROSS LENGTH = 46874 FT. = 8.88 MILE
NET LENGTH = 46874 FT. = 8.88 MILE

STATE OF ILLINOIS
DEPARTMENT OF TRANSPORTATION
DIVISION OF HIGHWAYS

SUBMITTED *January 20, 2010*

Scott E. Stett, P.E.
DEPUTY DIRECTOR OF HIGHWAYS, REGION ENGINEER

Christine M. Reed
ENGINEER OF DESIGN AND ENVIRONMENT

Christine M. Reed
DIRECTOR OF HIGHWAYS, CHIEF ENGINEER

**PRINTED BY THE AUTHORITY
OF THE STATE OF ILLINOIS**

AVAILABILITY OF ELECTRONIC FILES

Micro Station and GEOPAK files of this project will be made available to the Contractor. If there is a conflict between the electronic files and the printed contract plans and documents, the printed contract plans and documents shall take precedence over the electronic files. The Contractor shall accept all risk associated with using the electronic files and shall hold the Department harmless for any errors or omissions in the electronic files and the data contained therein. Errors or delays resulting from the use of the electronic files by the Contractor shall not result in an extension of time for any interim or final completion date or shall not be considered cause for additional compensation. The Contractor shall not use, share, or distribute these electronic files except for the purpose of constructing this contract. Any claims by third parties due to use or errors shall be the responsibility of the Contractor. The Contractor shall include this disclaimer with the transfer of these electronic files to any other parties and shall include appropriate language binding them to similar responsibilities.

PAVEMENT STATIONING NUMBERS & PLACEMENT

The Contractor shall provide labor and materials required to imprint pavement station numbers in the finished surface of the pavement and/or overlay. The numbers shall be approximately 3/4 inch (20mm) wide, 5 inches (125 mm) high and 5/8 inch (15 mm) deep.

The pavement station numbers shall be installed as specified herein:

Interval – 200 feet (English stationing) or 100 meters (metric stationing)

Bottom of Numbers – 6 inches (150 mm) from the inside edge of the pavement marking

Location:

- * 2,3, & 5 Lane Pavements – right edge of pavement in direction of increasing stations
- * Multi-Lane Divided Roadways – outside edge of pavement in both directions
- * Ramps – along baseline edge of pavement

Position – stations shall be placed so they can be read from the adjacent shoulder

Format – English (Metric) pavement stations shall use this format "XXX (XX+X00)" where X represents the pavement station

This work will not be paid for separately, but will be considered included in the cost of the associated pavement and/or overlay pay items.

COMMITMENTS

Commitments are not to be altered without the written approval of all parties to which the commitment was made.
THERE ARE NO COMMITMENTS.

CRITICAL PATH WORK SCHEDULE REQUIREMENT

The Contractor will submit to the Engineer a satisfactory progress schedule and critical path schedule which shall show the proposed sequence of work at the time of the pre-construction conference.

406.01 BRIDGE OVERLAY NOTIFICATION

After placement of the bridge deck overlay, the Resident Engineer shall notify the District Bridge Maintenance Engineer of the "as constructed" milling depth and overlay thickness for updating the Illinois Highway Information System.

PAVING SURFACE COURSE

Continuous paving operations on the main roadway shall be maintained at all times during the construction of the hot-mix asphalt surface. No interruptions for side roads, entrances, turn lanes, etc. will be allowed.

ENGINEERS FIELD OFFICE

Add the following sentence to the end of paragraph 670.02 (i) and 670.04 (e):
 All of the telephone lines provided shall have unpublished numbers.

BUTT JOINT CUTTING TIME RESTRICTION

Butt joints shall not be milled more than three (3) days prior to placement of the bituminous surface course.

FILE NAME = 1116.dgn	USER NAME = hudelsonme	DESIGNED -	REVISED -	STATE OF ILLINOIS DEPARTMENT OF TRANSPORTATION	GENERAL NOTES & COMMITMENTS	F.A.P. RTE.	SECTION	COUNTY	TOTAL SHEETS	SHEET NO.
	PLOT SCALE = 100.0000' / IN.	DRAWN -	REVISED -			673	..	TAZE/WOOD	60	3
	PLOT DATE = 1/29/2010	CHECKED -	REVISED -			CONTRACT NO. 68920		ILLINOIS FED. AID PROJECT		
		DATE -	REVISED -	SCALE:	SHEET NO.	OF	SHEETS	STA.	TO STA.	

EAST PEORIA

CONSTRUCTION CODE

CODE NO.	ITEM	UNIT	TOTAL QUANTITY	CONSTRUCTION CODE											
				URBAN	TAZEWELL ROADWAY I000	WOODFORD ROADWAY I000	TAZEWELL BRIDGE SFTY-2A	TAZEWELL SIGNALS Y031-1F	TAZEWELL SIGNALS Y031-1F	TAZEWELL SIGNALS Y031-1F	TAZEWELL FIBER OPT ITS-Y035	WOODFORD SIGNALS Y031-1F	WOODFORD FIBER OPT ITS-Y035		
					80 FED 20 STATE	80 FED 20 STATE	80 FED 20 STATE	80 FED 20 STATE	80/10/10 FED/ST/CIT	80/13.3/6.7 FED/ST/CIT	80 FED 20 STATE	80 FED 20 STATE	80 FED 20 STATE		
40600215	POLYMERIZED BITUMINOUS MATERIALS (PRIME COAT)	TON	210		128	82									
40600300	AGGREGATE (PRIME COAT)	TON	1104		711	393									
40600826	POLYMERIZED LEVELING BINDER (MACHINE METHOD), IL-4.75, N50	TON	7075		7075										
40600895	CONSTRUCTING TEST STRIP	EACH	2		1	1									
40600982	HOT-MIX ASPHALT SURFACE REMOVAL - BUTT JOINT	SQ YD	4435		3508	927									
40600990	TEMPORARY RAMP	SQ YD	2147		1220	927									
40603565	POLYMERIZED HOT-MIX ASPHALT SURFACE COURSE, MIX "E", N70	TON	25440		15544	9896									
40800050	INCIDENTAL HOT-MIX ASPHALT SURFACING	TON	1420		870	550									
44000152	HOT-MIX ASPHALT SURFACE REMOVAL, 3/4"	SQ YD	184190		184190										
44000155	HOT-MIX ASPHALT SURFACE REMOVAL, 1 1/2"	SQ YD	235107		40861	194246									
44000915	HOT-MIX ASPHALT SURFACE REMOVAL (DECK)	SQ YD	659			659									
44201019	CLASS B PATCHES, TYPE II, 14 INCH	SQ YD	3936		2099	1837									
44201023	CLASS B PATCHES, TYPE III, 14 INCH	SQ YD	704		640	64									
44201025	CLASS B PATCHES, TYPE IV, 14 INCH	SQ YD	1362		1362										
44213100	PAVEMENT FABRIC	SQ YD	2066		2002	64									
44213200	SAW CUTS	FOOT	26204		16502	9702									
48101200	AGGREGATE SHOULDERS, TYPE B	TON	3859		2786	1073									
48203100	HOT-MIX ASPHALT SHOULDERS	TON	14206		8109	6097									
50102400	CONCRETE REMOVAL	CU YD	12.3			12.3									
50300255	CONCRETE SUPERSTRUCTURE	CU YD	12.2			12.2									
50300260	BRIDGE DECK GROOVING	SQ YD	659			659									
50300300	PROTECTIVE COAT	SQ YD	659			659									

* SPECIALTY ITEM

FILE NAME = 11116.dgn
 USER NAME = hudelsonne
 PLOT SCALE = 100.0000' / IN.
 PLOT DATE = 1/29/2010

DESIGNED -	REVISD -
DRAWN -	REVISD -
CHECKED -	REVISD -
DATE -	REVISD -

STATE OF ILLINOIS
 DEPARTMENT OF TRANSPORTATION

SUMMARY OF QUANTITIES

SCALE: SHEET NO. OF SHEETS STA. TO STA.

F.A.P. RTE. 673
 SECTION **
 COUNTY TAZE/WOOD
 TOTAL SHEETS 60
 SHEET NO. 4
 CONTRACT NO. 68920
 ILLINOIS FED. AID PROJECT

** 101RS-3; 102RS-4; 103RS-4; 104RS-7

EAST PEORIA

CONSTRUCTION CODE

CODE NO.	ITEM	UNIT	TOTAL QUANTITY	CONSTRUCTION CODE											
				URBAN	TAZEWELL ROADWAY I000	WOODFORD ROADWAY I000	TAZEWELL BRIDGE SFTY-2A	TAZEWELL SIGNALS Y031-1F	TAZEWELL SIGNALS Y031-1F	TAZEWELL SIGNALS Y031-1F	TAZEWELL FIBER OPT ITS-Y035	WOODFORD SIGNALS Y031-1F	WOODFORD FIBER OPT ITS-Y035		
					80 FED 20 STATE	80 FED 20 STATE	80 FED 20 STATE	80 FED 20 STATE	80/10/10 FED/ST/CIT	80/13.3/6.7 FED/ST/CIT	80 FED 20 STATE	80 FED 20 STATE	80 FED 20 STATE		
50800205	REINFORCEMENT BARS, EPOXY COATED	POUND	1560				1560								
50800515	BAR SPLICERS	EACH	22				22								
52000110	PREFORMED JOINT STRIP SEAL	FOOT	54.5				54.5								
60300105	FRAMES AND GRATES TO BE ADJUSTED	EACH	16	16											
* 63000001	STEEL PLATE BEAM GUARD RAIL, TYPE A, 6 FOOT POSTS	FOOT	2437.5	2437.5											
* 63000025	STEEL PLATE BEAM GUARD RAIL, ATTACHED TO STRUCTURES	FOOT	37.5	37.5											
* 63100045	TRAFFIC BARRIER TERMINAL, TYPE 2	EACH	11	11											
* 63100085	TRAFFIC BARRIER TERMINAL, TYPE 6	EACH	3	3											
* 63100167	TRAFFIC BARRIER TERMINAL, TYPE 1(SPECIAL) TANGENT	EACH	15	15											
63200310	GUARD RAIL REMOVAL	FOOT	3059	3059											
63200700	STEEL PLATE BEAM GUARD RAIL REMOVAL, DOUBLE RAIL	FOOT	416	64	352										
67000400	ENGINEER'S FIELD OFFICE, TYPE A	CAL MO	5	5											
67100100	MOBILIZATION	L SUM	1	1											
70100310	TRAFFIC CONTROL AND PROTECTION, STANDARD 701421	L SUM	1	1											
70100325	TRAFFIC CONTROL AND PROTECTION, STANDARD 701423	EACH	1	1											
70100420	TRAFFIC CONTROL AND PROTECTION, STANDARD 701411	EACH	5	5											
70102635	TRAFFIC CONTROL AND PROTECTION, STANDARD 701701	L SUM	1	1											
70103815	TRAFFIC CONTROL SURVEILLANCE	CAL DA	40	40											
70106800	CHANGEABLE MESSAGE SIGN	CAL MO	20	20											
70300100	SHORT-TERM PAVEMENT MARKING	FOOT	30972	18690	12282										
70300210	TEMPORARY PAVEMENT MARKING - LETTERS AND SYMBOLS	SQ FT	3256.8	2076.4	1180.4										
70300220	TEMPORARY PAVEMENT MARKING - LINE 4"	FOOT	200362	120886	79476										

* SPECIALTY ITEM

** 101RS-3; 102RS-4; 103RS-4; 104RS-7

FILE NAME = 1116.dgn	USER NAME = hudeisonme	DESIGNED - DRAWN -	REVISED - REVISED -
	PLOT SCALE = 100.0000" / IN.	CHECKED -	REVISED -
	PLOT DATE = 1/29/2010	DATE -	REVISED -

STATE OF ILLINOIS
DEPARTMENT OF TRANSPORTATION

SUMMARY OF QUANTITIES

SCALE: SHEET NO. OF SHEETS STA. TO STA.

F.A.P RTE. 673	SECTION ..	COUNTY TAZE/WOOD	TOTAL SHEETS 60	SHEET NO. 5
CONTRACT NO. 68920				ILLINOIS FED. AID PROJECT

EAST PEORIA

CODE NO.	ITEM	UNIT	TOTAL QUANTITY	CONSTRUCTION CODE											
				URBAN			TAZEWELL ROADWAY	WOODFORD ROADWAY	TAZEWELL BRIDGE	TAZEWELL SIGNALS	TAZEWELL SIGNALS	TAZEWELL SIGNALS	TAZEWELL FIBER OPT	WOODFORD SIGNALS	WOODFORD FIBER OPT
				I000	I000	SFTY-2A	Y031-1F	Y031-1F	Y031-1F	ITS-Y035	Y031-1F	ITS-Y035			
80 FED 20 STATE	80 FED 20 STATE	80 FED 20 STATE	80 FED 20 STATE	80/10/10 FED/ST/CIT	80/13.3/6.7 FED/ST/CIT	80 FED 20 STATE	80 FED 20 STATE	80 FED 20 STATE							
70300240	TEMPORARY PAVEMENT MARKING - LINE 6"	FOOT	23448	14024	9424										
70300250	TEMPORARY PAVEMENT MARKING - LINE 8"	FOOT	21730	17853	3877										
70300260	TEMPORARY PAVEMENT MARKING - LINE 12"	FOOT	4874	3953	921										
70300280	TEMPORARY PAVEMENT MARKING - LINE 24"	FOOT	1527	965	562										
70300520	PAVEMENT MARKING TAPE, TYPE III 4"	FOOT	4940	4940											
70301000	WORK ZONE PAVEMENT MARKING REMOVAL	SQ FT	11971	4094	7877										
70400100	TEMPORARY CONCRETE BARRIER	FOOT	321	321											
70400200	RELOCATE TEMPORARY CONCRETE BARRIER	FOOT	321	321											
* 78003100	PREFORMED PLASTIC PAVEMENT MARKING, TYPE B - LETTERS AND SYMBOLS	SQ FT	298	298											
* 78003130	PREFORMED PLASTIC PAVEMENT MARKING, TYPE B - LINE 6"	FOOT	23448	14024	9424										
* 78100100	RAISED REFLECTIVE PAVEMENT MARKER	EACH	1498	1026	472										
* 78200410	GUARDRAIL MARKERS, TYPE A	EACH	46	46											
* 78201000	TERMINAL MARKER - DIRECT APPLIED	EACH	15	15											
78300100	PAVEMENT MARKING REMOVAL	SQ FT	124	124											
78300200	RAISED REFLECTIVE PAVEMENT MARKER REMOVAL	EACH	1498	1026	472										
* 81012600	CONDUIT IN TRENCH, 2" DIA., PVC	FOOT	21523							9718		11805			
* 81021350	CONDUIT PUSHED, 3" DIA., PVC	FOOT	950							540		410			
* 81100600	CONDUIT ATTACHED TO STRUCTURE, 2" DIA., GALVANIZED STEEL	FOOT	211							211					
* 81300948	JUNCTION BOX, STAINLESS STEEL, ATTACHED TO STRUCTURE, 24" X 24" X 10"	EACH	4							4					
* 81400720	DOUBLE HANDHOLE, PORTLAND CEMENT CONCRETE	EACH	13							6		7			
* 81900200	TRENCH AND BACKFILL FOR ELECTRICAL WORK	FOOT	21523							9718		11805			
* 85700205	FULL-ACTUATED CONTROLLER AND TYPE IV CABINET, SPECIAL	EACH	1								1				

* SPECIALTY ITEM

** 101RS-3; 102RS-4; 103RS-4; 104RS-7

FILE NAME = 11116.dgn	USER NAME = hudeisonne	DESIGNED -	REVISED -
		DRAWN -	REVISED -
	PLOT SCALE = 100.0000" / IN.	CHECKED -	REVISED -
	PLOT DATE = 1/29/2010	DATE -	REVISED -

STATE OF ILLINOIS
DEPARTMENT OF TRANSPORTATION

SUMMARY OF QUANTITIES

SCALE: SHEET NO. OF SHEETS STA. TO STA.

F.A.P. RTE. 673	SECTION **	COUNTY TAZE/WOOD	TOTAL SHEETS 60	SHEET NO. 6
CONTRACT NO. 68920			ILLINOIS FED. AID PROJECT	

EAST PEORIA

CODE NO.	ITEM	UNIT	TOTAL QUANTITY	CONSTRUCTION CODE									
				URBAN	TAZEWELL ROADWAY	WOODFORD ROADWAY	TAZEWELL BRIDGE	TAZEWELL SIGNALS	TAZEWELL SIGNALS	TAZEWELL SIGNALS	TAZEWELL FIBER OPT	WOODFORD SIGNALS	WOODFORD FIBER OPT
					I000	I000	SFTY-2A	Y031-1F	Y031-1F	Y031-1F	ITS-Y035	Y031-1F	ITS-Y035
	80 FED 20 STATE	80 FED 20 STATE	80 FED 20 STATE	80 FED 20 STATE	80/10/10 FED/ST/CIT	80/13.3/6.7 FED/ST/CIT	80 FED 20 STATE	80 FED 20 STATE	80 FED 20 STATE				
* 87301245	ELECTRIC CABLE IN CONDUIT, SIGNAL NO. 14 5C	FOOT	755.5							297		458.5	
* 87900200	DRILL EXISTING HANDHOLE	EACH	1								1		
* 88500100	INDUCTIVE LOOP DETECTOR	EACH	8							8			
* 88600100	DETECTOR LOOP, TYPE I	FOOT	6661	3,103				572				2886	
* 88800100	PEDESTRIAN PUSH-BUTTON	EACH	8									8	
* 89502105	REBUILD EXISTING SIGNAL HEAD, LED	EACH	8					4		4			
* 89502210	MODIFY EXISTING CONTROLLER CABINET	EACH	2					1				1	
Z0006204	BRIDGE DECK HYDRO-SCARIFICATION 1/2"	SQYD	659				659						
Z0017100	DOWEL BARS	EACH	10440	5960	4480								
Z0024478	FLEXIBLE DELINEATORS	EACH	38	38									
* Z0030130	IMPACT ATTENUATORS (PARTIALLY REDIRECTIVE), TEST LEVEL 3	EACH	13	2	11								
* Z0030250	IMPACT ATTENUATORS, TEMPORARY (NON- REDIRECTIVE), TEST LEVEL 3	EACH	1	1									
* Z0030350	IMPACT ATTENUATORS, RELOCATE (NON- REDIRECTIVE), TEST LEVEL 3	EACH	1	1									
Z0075310	TIE BARS 3/4"	EACH	1000	500	500								
X0301512	GUARDRAIL AGGREGATE EROSION CONTROL	TON	691	691									
X0322185	BRIDGE DECK LATEX CONCRETE OVERLAY, 2 1/4 INCHES	SQ YD	659			659							
X0322729	MATERIAL TRANSFER DEVICE	TON	22006	13287	8719								
* X0323336	LED SIGNAL FACE RETROFIT, RED BALL	EACH	22									22	
* X0323337	LED SIGNAL FACE RETROFIT, GREEN BALL	EACH	21									21	
* X0323420	LED SIGNAL FACE RETROFIT, GREEN ARROW	EACH	6									6	
* X0326101	BOND TRAFFIC SIGNAL STRUCTURE	EACH	28									28	
* X0326851	ADJUST EXISTING DETECTOR LOOP RISER	EACH	40	21				5				14	

* SPECIALTY ITEM

FILE NAME = 11116.dgn
 USER NAME = hudeisonme
 PLOT SCALE = 100.0000' / IN.
 PLOT DATE = 1/29/2010

DESIGNED -	REVISED -
DRAWN -	REVISED -
CHECKED -	REVISED -
DATE -	REVISED -

STATE OF ILLINOIS
 DEPARTMENT OF TRANSPORTATION

SUMMARY OF QUANTITIES

SCALE:	SHEET NO. OF SHEETS	STA. TO STA.
--------	---------------------	--------------

F.A.P. RTE.	SECTION	COUNTY	TOTAL SHEETS	SHEET NO.
673	**	TAZE/WOOD	60	7
CONTRACT NO. 68920				
ILLINOIS FED. AID PROJECT				

** 101RS-3; 102RS-4; 103RS-4; 104RS-7

EAST PEORIA

CONSTRUCTION CODE

CODE NO.	ITEM	UNIT	URBAN TOTAL QUANTITY	TAZEWELL ROADWAY	WOODFORD ROADWAY	TAZEWELL BRIDGE	TAZEWELL SIGNALS	TAZEWELL SIGNALS	TAZEWELL SIGNALS	TAZEWELL FIBER OPT	WOODFORD SIGNALS	WOODFORD FIBER OPT
				I000	I000	SFTY-2A	Y031-1F	Y031-1F	Y031-1F	ITS-Y035	Y031-1F	ITS-Y035
				80 FED 20 STATE	80 FED 20 STATE	80 FED 20 STATE	80 FED 20 STATE	80/10/10 FED/ST/CIT	80/13.3/6.7 FED/ST/CIT	80 FED 20 STATE	80 FED 20 STATE	80 FED 20 STATE
* X7200201	WIDTH RESTRICTION SIGNING	L SUM	1	1								
* X7800600	URETHANE PAVEMENT MARKING - LETTERS AND SYMBOLS, SPECIAL	SQ FT	2958.8	1778.4	1180.4							
* X7800610	URETHANE PAVEMENT MARKING - LINE 4"	FOOT	200362	120886	79476							
* X7800640	URETHANE PAVEMENT MARKING - LINE 8"	FOOT	21730	17853	3877							
* X7800650	URETHANE PAVEMENT MARKING - LINE 12"	FOOT	4874	3953	921							
* X7800680	URETHANE PAVEMENT MARKING - LINE 24"	FOOT	1527	965	562							
* X8710070	FIBER OPTIC INTERCONNECT CENTER, 24 FIBER	FOOT	3							1		2
* X8730027	ELECTRIC CABLE IN CONDUIT, GROUNDING, NO. 6 1C	FOOT	1498								1498	
* X8710024	FIBER OPTIC CABLE IN CONDUIT, NO. 62.5/125, MM12F SM24F	FOOT	30536							11486		19050

* SPECIALTY ITEM

** 101RS-3; 102RS-4; 103RS-4; 104RS-7

FILE NAME = 11116.dgn	USER NAME = hudeisonme	DESIGNED -	REVISED -
		DRAWN -	REVISED -
	PLOT SCALE = 100.0000' / IN.	CHECKED -	REVISED -
	PLOT DATE = 1/29/2010	DATE -	REVISED -

STATE OF ILLINOIS
DEPARTMENT OF TRANSPORTATION

SUMMARY OF QUANTITIES

SCALE: SHEET NO. OF SHEETS STA. TO STA.

F.A.P. RTE.	SECTION	COUNTY	TOTAL SHEETS	SHEET NO.
673	**	TAZE/WOOD	60	3
			CONTRACT NO. 68920	
ILLINOIS FED. AID PROJECT				

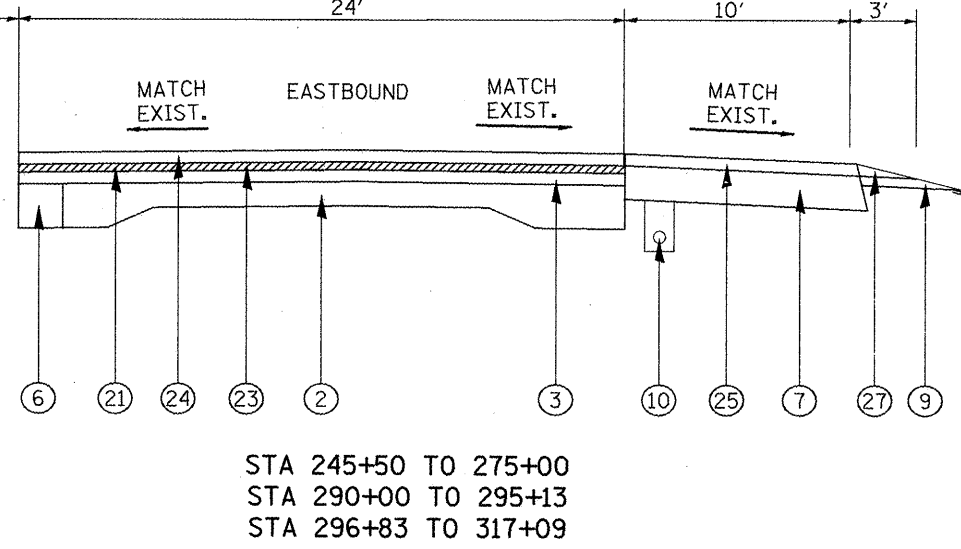
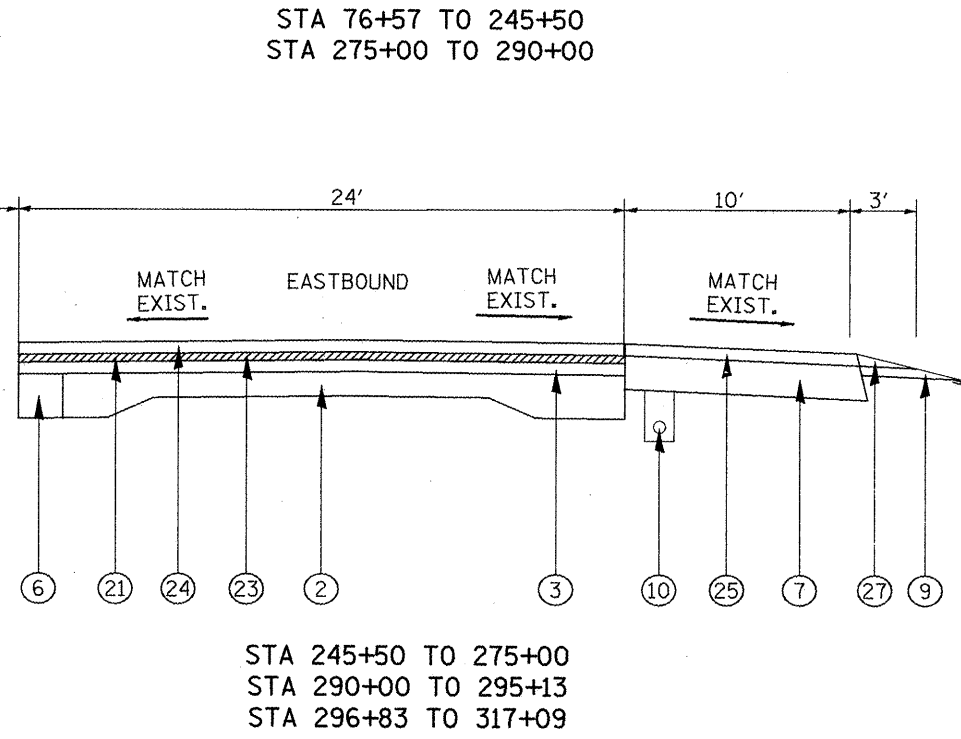
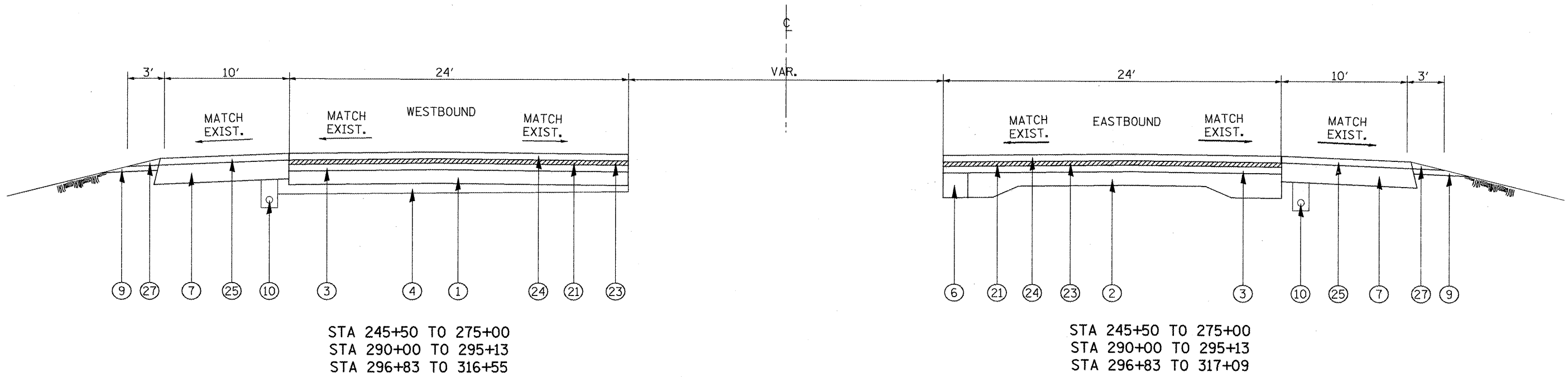
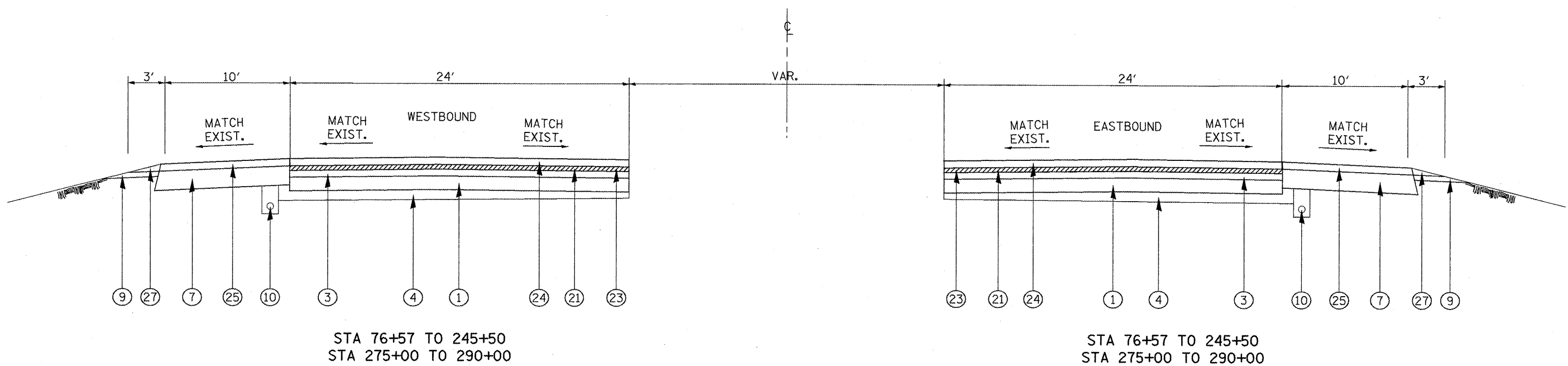

LEGEND

- | | |
|--|---|
| ① EXISTING PCC PAVEMENT 10" | ②① PROPOSED HOT-MIX ASPHALT REMOVAL 3/4" |
| ② EXISTING PCC PAVEMENT 9-6-9 | ②② PROPOSED HOT-MIX ASPHALT REMOVAL 1 1/2" |
| ③ EXISTING BITUMINOUS OVERLAY ** | ②③ PROPOSED POLYMERIZED LEVELING BINDER (MACHINE METHOD), IL-4.75, N50, 3/4" |
| ④ EXISTING SUB-BASE 4" | ②④ PROPOSED POLYMERIZED HMA SURFACE COURSE, MIX "E", N70 1 1/2" |
| ⑤ EXISTING BITUMINOUS BASE COURSE | ②⑤ PROPOSED HOT-MIX ASPHALT SHOULDERS 1 1/2" |
| ⑥ EXISTING PCC BASE COURSE WIDENING 8" | ②⑥ PROPOSED HOT-MIX ASPHALT SHOULDERS 2 1/4" |
| ⑦ EXISTING BITUMINOUS SHOULDERS | ②⑦ PROPOSED AGGREGATE SHOULDERS, TYPE B, WEDGE |
| ⑧ EXISTING BITUMINOUS MEDIAN | |
| ⑨ EXISTING AGGREGATE SHOULDERS | ** BITUMINOUS OVERLAY HAS AREA REFLECTIVE CRACK CONTROL FROM STA 76+57 TO STA 440+80. |
| ⑩ EXISTING PIPE UNDERDRAIN | |
| ⑪ EXISTING GUARDRAIL | |
| ⑫ EXISTING CONCRETE MEDIAN | |

FILE NAME = 1116.dgn	USER NAME = hudelsonme	DESIGNED -	REVISED -
		DRAWN -	REVISED -
		CHECKED -	REVISED -
		DATE -	REVISED -

**STATE OF ILLINOIS
DEPARTMENT OF TRANSPORTATION**

TYPICAL SECTIONS

SCALEs SHEET NO. OF SHEETS STA. TO STA.

F.A.P. RTE. 673	SECTION ..	COUNTY TAZE/WOOD	TOTAL SHEETS 60	SHEET NO. 9
CONTRACT NO. 68920				
ILLINOIS FED. AID PROJECT				

** 101RS-3; 102RS-4; 103RS-4; 104RS-7

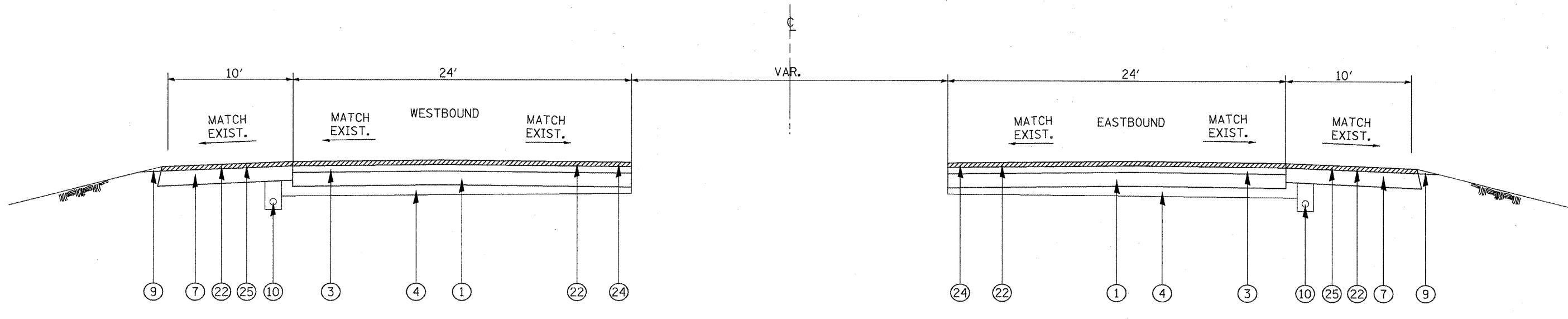

STA 295+13 TO 296+83
STA 340+47 TO 543+64

STA 295+13 TO 296+83
STA 340+47 TO 343+37
STA 394+00 TO 543+64

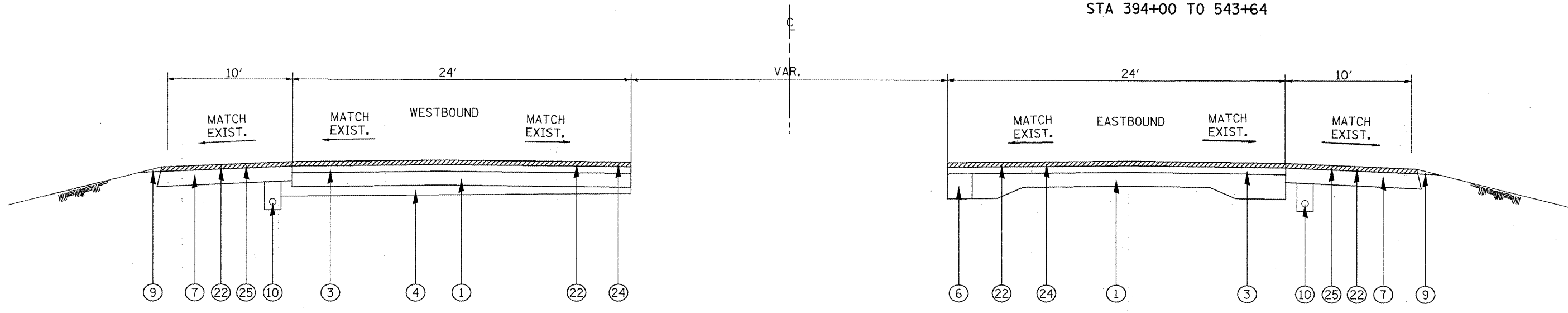

STA 318+09 TO 340+47

STA 318+64 TO 340+47

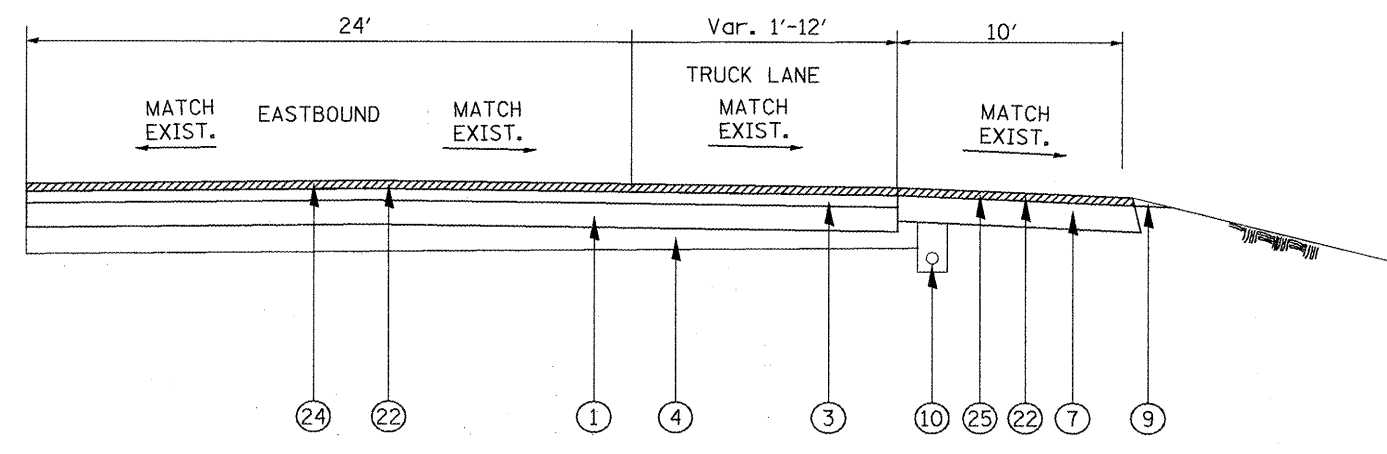

STA 343+37 TO 394+00

LEGEND

- | | |
|--|--|
| ① EXISTING PCC PAVEMENT 10" | ②① PROPOSED HOT-MIX ASPHALT REMOVAL 3/4" |
| ② EXISTING PCC PAVEMENT 9-6-9 | ②② PROPOSED HOT-MIX ASPHALT REMOVAL 1 1/2" |
| ③ EXISTING BITUMINOUS OVERLAY | ②③ PROPOSED POLYMERIZED LEVELING BINDER (MACHINE METHOD), IL-4.75, N50, 3/4" |
| ④ EXISTING SUB-BASE 4" | ②④ PROPOSED POLYMERIZED HMA SURFACE COURSE, MIX "E", N70 1 1/2" |
| ⑤ EXISTING BITUMINOUS BASE COURSE | ②⑤ PROPOSED HOT-MIX ASPHALT SHOULDERS 1 1/2" |
| ⑥ EXISTING PCC BASE COURSE WIDENING 8" | ②⑥ PROPOSED HOT-MIX ASPHALT SHOULDERS 2 1/4" |
| ⑦ EXISTING BITUMINOUS SHOULDERS | ②⑦ PROPOSED AGGREGATE SHOULDERS, TYPE B, WEDGE |
| ⑧ EXISTING BITUMINOUS MEDIAN | |
| ⑨ EXISTING AGGREGATE SHOULDERS | |
| ⑩ EXISTING PIPE UNDERDRAIN | |
| ⑪ EXISTING GUARDRAIL | |
| ⑫ EXISTING CONCRETE MEDIAN | |
- BITUMINOUS OVERLAY HAS AREA REFLECTIVE CRACK CONTROL FROM STA 76+57 TO STA 440+80.

FILE NAME = 1116.dgn	USER NAME = hudelsonne	DESIGNED -	REVISED -
		DRAWN -	REVISED -
		CHECKED -	REVISED -
		DATE -	REVISED -

STATE OF ILLINOIS
DEPARTMENT OF TRANSPORTATION

TYPICAL SECTIONS

SCALE: SHEET NO. OF SHEETS STA. TO STA.

F.A.P. RTE. 673	SECTION **	COUNTY TAZEWOOD	TOTAL SHEETS 60	SHEET NO. 10
CONTRACT NO. 68920				ILLINOIS FED. AID PROJECT

•• 101RS-3; 102RS-4; 103RS-4; 104RS-7

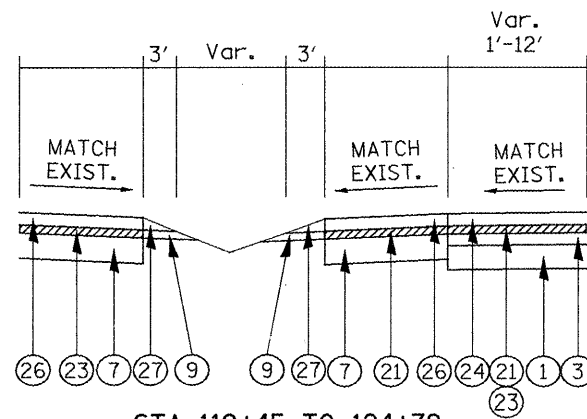

STA 119+45 TO 124+79
 STA 140+31 TO 145+31
 STA 193+86 TO 199+34
 STA 243+00 TO 248+67
 STA 261+53 TO 266+33
 STA 280+84 TO 285+28
 STA 290+20 TO 295+79
 STA 297+35 TO 301+03
 STA 319+52 TO 326+42

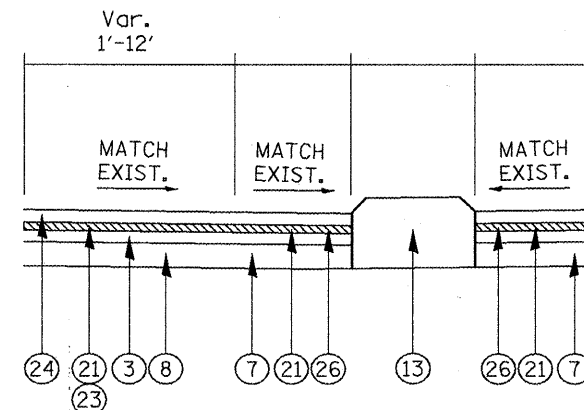

STA 88+95 TO 92+23

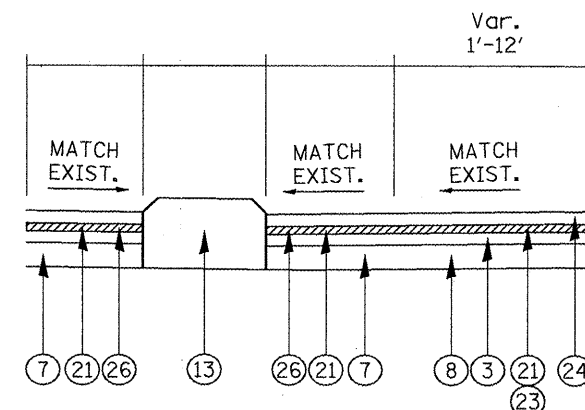

STA 85+70 TO 88+95

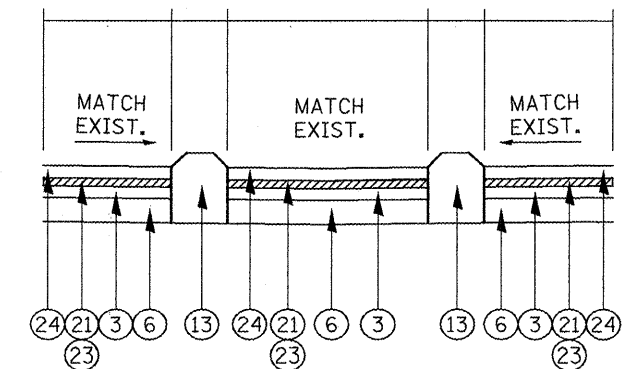

STA 184+25 TO 193+50
 STA 285+28 TO 286+42

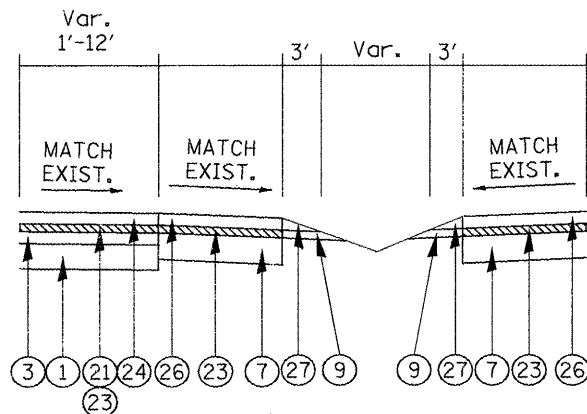

STA 145+31 TO 150+30
 STA 180+02 TO 184+25
 STA 193+50 TO 196+45
 STA 266+33 TO 271+12
 STA 296+53 TO 300+20
 STA 301+03 TO 305+86

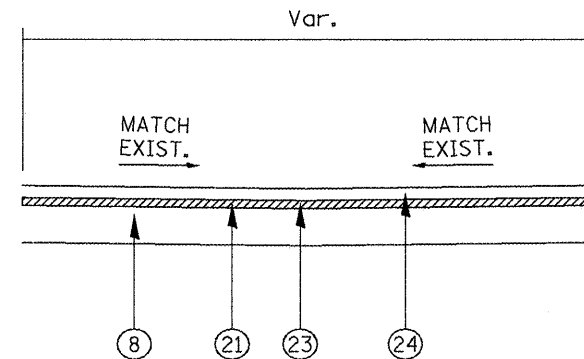

STA 76+27 TO 85+70
 STA 92+23 TO 96+00
 STA 104+87 TO 106+08
 STA 117+46 TO 118+70
 STA 131+79 TO 133+05
 STA 273+10 TO 274+83
 STA 307+30 TO 308+72

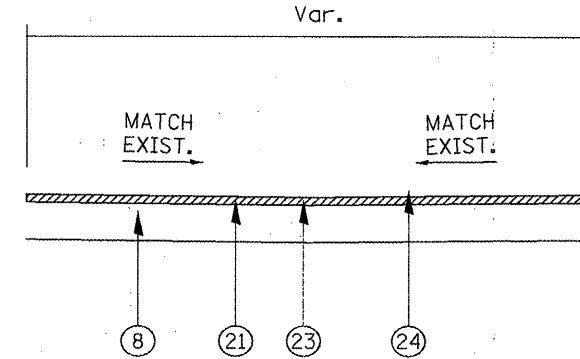

STA 295+13 TO 296+83

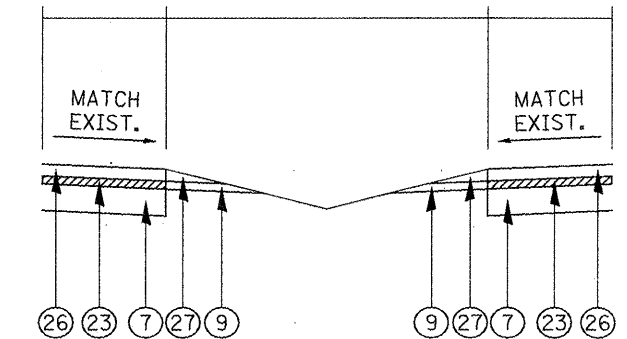

STA 96+00 TO 104+87
 STA 106+08 TO 117+46
 STA 118+70 TO 119+45
 STA 124+79 TO 131+79
 STA 133+05 TO 140+31
 STA 150+30 TO 180+02
 STA 199+34 TO 243+00
 STA 248+67 TO 261+53
 STA 271+12 TO 273+10
 STA 274+83 TO 280+84
 STA 286+42 TO 290+20
 STA 305+86 TO 307+30
 STA 308+72 TO 319+52
 STA 326+42 TO 331+60

LEGEND

- | | |
|--|--|
| ① EXISTING PCC PAVEMENT 10" | ②① PROPOSED HOT-MIX ASPHALT REMOVAL 3/4" |
| ② EXISTING PCC PAVEMENT 9-6-9 | ②② PROPOSED HOT-MIX ASPHALT REMOVAL 1 1/2" |
| ③ EXISTING BITUMINOUS OVERLAY | ②③ PROPOSED POLYMERIZED LEVELING BINDER (MACHINE METHOD), IL-4.75, N50, 3/4" |
| ④ EXISTING SUB-BASE 4" | ②④ PROPOSED POLYMERIZED HMA SURFACE COURSE, MIX "E", N70 1 1/2" |
| ⑤ EXISTING BITUMINOUS BASE COURSE | ②⑤ PROPOSED HOT-MIX ASPHALT SHOULDERS 1 1/2" |
| ⑥ EXISTING PCC BASE COURSE WIDENING 8" | ②⑥ PROPOSED HOT-MIX ASPHALT SHOULDERS 2 1/4" |
| ⑦ EXISTING BITUMINOUS SHOULDERS | ②⑦ PROPOSED AGGREGATE SHOULDERS, TYPE B, WEDGE |
| ⑧ EXISTING BITUMINOUS MEDIAN | |
| ⑨ EXISTING AGGREGATE SHOULDERS | |
| ⑩ EXISTING PIPE UNDERDRAIN | |
| ⑪ EXISTING GUARDRAIL | |
| ⑫ EXISTING CONCRETE MEDIAN | |
- ** BITUMINOUS OVERLAY HAS AREA REFLECTIVE CRACK CONTROL FROM STA 76+57 TO STA 440+80.

See Job Specific Note #2

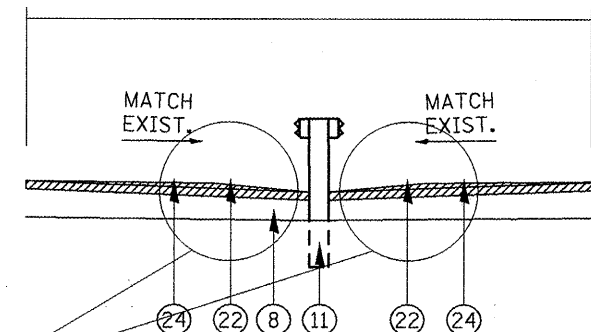

STA 331+60 TO 334+98
 STA 340+47 TO 394+75
 STA 400+26 TO 433+00
 STA 436+80 TO 474+14

FILE NAME = s1116.dgn	USER NAME = hudeisonme	DESIGNED -	REVISED -
		DRAWN -	REVISED -
		CHECKED -	REVISED -
		DATE -	REVISED -

**STATE OF ILLINOIS
 DEPARTMENT OF TRANSPORTATION**

TYPICAL SECTIONS

SCALE: SHEET NO. OF SHEETS STA. TO STA.

F.A.P. RTE. 673	SECTION **	COUNTY TAZE/WOOD	TOTAL SHEETS 60	SHEET NO. 11
			CONTRACT NO. 68920	

** 101RS-3; 102RS-4; 103RS-4; 104RS-7

ILLINOIS FED. AID PROJECT

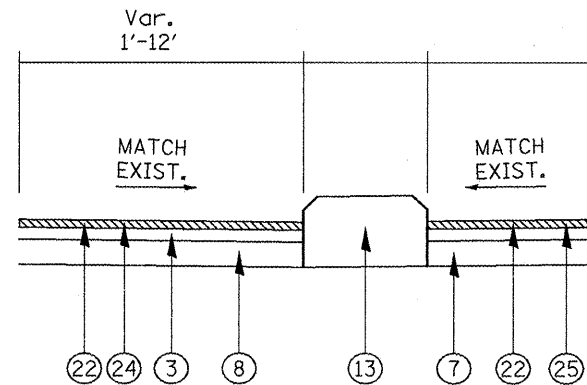

STA 480+36 TO 485+19
 STA 496+50 TO 501+47
 STA 515+34 TO 520+17
 STA 538+57 TO 543+40

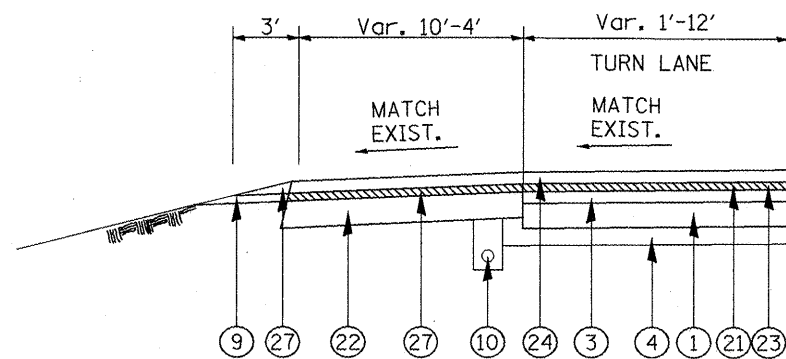

STA 84+17 TO 88+17
 STA 140+15 TO 144+15
 STA 186+86 TO 190+75
 STA 261+34 TO 265+34
 STA 292+18 TO 295+49
 STA 297+11 TO 300+67

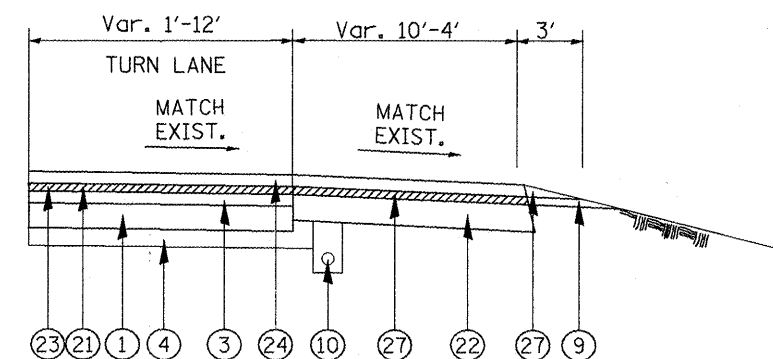

STA 90+11 TO 94+11
 STA 125+36 TO 129+36
 STA 146+47 TO 150+47
 STA 200+14 TO 204+14
 STA 267+06 TO 268+76
 STA 273+20 TO 283+00
 STA 287+81 TO 292+61
 STA 295+13 TO 299+13
 STA 302+16 TO 306+16

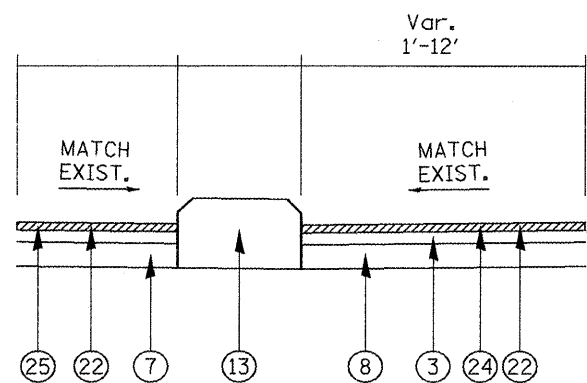

STA 334+98 TO 340+47
 STA 394+75 TO 400+26
 STA 433+00 TO 436+80

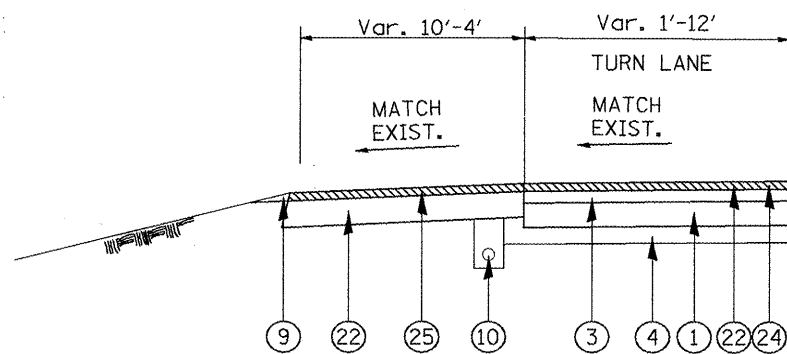

STA 474+14 TO 478+97
 STA 490+18 TO 495+07
 STA 509+18 TO 514+00
 STA 532+06 TO 536+86

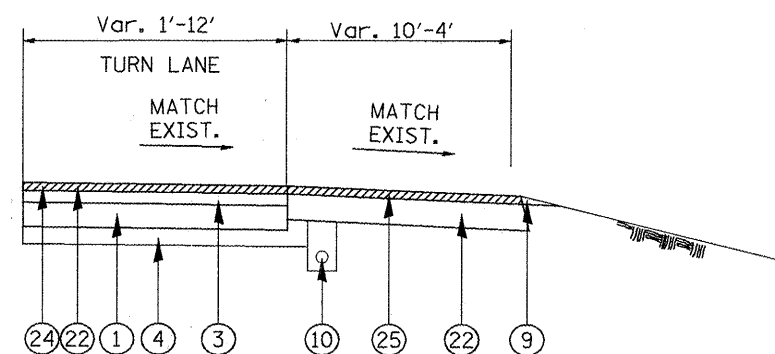

STA 480+41 TO 485+09 *enterline IL 116*
 STA 496+66 TO 501+47
 STA 538+59 TO 543+40

LEGEND

- | | |
|--|---|
| ① EXISTING PCC PAVEMENT 10" | ②① PROPOSED HOT-MIX ASPHALT REMOVAL 3/4" |
| ② EXISTING PCC PAVEMENT 9-6-9 | ②② PROPOSED HOT-MIX ASPHALT REMOVAL 1 1/2" |
| ③ EXISTING BITUMINOUS OVERLAY | ③ PROPOSED POLYMERIZED LEVELING BINDER (MACHINE METHOD), IL-4.75, N50, 3/4" |
| ④ EXISTING SUB-BASE 4" | ④ PROPOSED POLYMERIZED HMA SURFACE COURSE, MIX "E", N70 1 1/2" |
| ⑤ EXISTING BITUMINOUS BASE COURSE | ⑤ PROPOSED HOT-MIX ASPHALT SHOULDERS 1 1/2" |
| ⑥ EXISTING PCC BASE COURSE WIDENING 8" | ⑥ PROPOSED HOT-MIX ASPHALT SHOULDERS 2 1/4" |
| ⑦ EXISTING BITUMINOUS SHOULDERS | ⑦ PROPOSED AGGREGATE SHOULDERS, TYPE B, WEDGE |
| ⑧ EXISTING BITUMINOUS MEDIAN | |
| ⑨ EXISTING AGGREGATE SHOULDERS | |
| ⑩ EXISTING PIPE UNDERDRAIN | ** BITUMINOUS OVERLAY HAS AREA REFLECTIVE CRACK CONTROL FROM STA 76+57 TO STA 440+80. |
| ⑪ EXISTING GUARDRAIL | |
| ⑫ EXISTING CONCRETE MEDIAN | |

FILE NAME = 11116.dgn

USER NAME = hudeisonme
 PLOT SCALE = 1/80.0000" / IN.
 PLOT DATE = 1/29/2018

DESIGNED -	REVISED -
DRAWN -	REVISED -
CHECKED -	REVISED -
DATE -	REVISED -

**STATE OF ILLINOIS
 DEPARTMENT OF TRANSPORTATION**

TYPICAL SECTIONS

SCALE: SHEET NO. OF SHEETS STA. TO STA.

F.A.P. RTE. 673	SECTION **	COUNTY	TOTAL SHEETS 60	SHEET NO. 12
ILLINOIS FED. AID PROJECT			CONTRACT NO. 68920	

•• 101RS-3; 102RS-4; 103RS-4; 104RS-7

RESURFACING TABLE (2 OF 7) - TAZEWELL COUNTY

LOCATION	DESCRIPTION	ROADWAY WIDTH	LENGTH	AREA	HOT-MIX ASPHALT REMOVAL BUTT JOINT		TEMPORARY RAMP	HOT-MIX ASPHALT REMOVAL 3/4"		HOT-MIX ASPHALT REMOVAL 1 1/2"		POLYMERIZED BITUMINOUS MATERIAL PRIME COAT	AGGREGATE PRIME COAT	POLYMERIZED LEVELING BINDER (MACH METH) IL-4.75 N50 3/4"	POLYMERIZED HOT-MIX ASPHALT SURFACE CSE MIX "E", N70 1 1/2"	INCIDENTAL HOT-MIX ASPHALT SURFACING 1 1/2"	HOT-MIX ASPHALT SHOULDERS		AGGREGATE SHOULDER TYPE B	
					RDWY	SHLDR		RDWY	SHLDR	RDWY	SHLDR						1 1/2"	2 1/4"		
																				SQ YD
201+84 TO 204+14	RT TURN LN	36 to 25	230	779.4				779.4				0.5	2.8	32.7	65.5		21.5		6.6	
204+14 TO 249+20		24	4506	12016				12016				7.3	46.1	504.7	1009.3		420.6		128.4	
249+20 TO 250+90	RT TURN LN	36	170	680				680				0.4	2.2	28.6	57.1		6.4		4.8	
250+90 TO 253+20	RT TURN LN	36 to 25	230	779.4				779.4				0.5	2.8	32.7	65.5		21.5		6.6	
253+20 TO 267+06		24	1386	3696				3696				2.3	14.2	155.2	310.5		129.4		39.5	
267+06 TO 268+76	RT TURN LN	36	170	680				680				0.4	2.2	28.6	57.1		6.4		4.8	
268+76 TO 271+06	RT TURN LN	36 to 25	230	779.4				779.4				0.5	2.8	32.7	65.5		21.5		6.6	
271+06 TO 273+20		24	214	570.7				570.7				0.4	2.2	24	47.9		20		6.1	
273+20 TO 283+00	RT TURN LN	36 to 25	980	3825.6				3825.6				2.3	13.7	160.7	321.4		91.5		27.9	
283+00 TO 287+81		24	481	1282.7				1282.7				0.8	4.9	53.9	107.7		44.9		13.7	
287+81 TO 290+41	RT TURN LN	36	260	1584				1584				0.9	5	66.5	133.1		9.7		7.4	
290+41 TO 292+61	RT TURN LN	36 to 25	220	745.6				745.6				0.5	2.7	31.3	62.6		20.5		6.3	
292+61 TO 295+13		24	252	672				672				0.5	2.6	28.2	56.4		23.5		7.2	
295+13 TO 295+79	TRANSITION	36	66	264					29.3	264		0.2	0.9	11.1	22.2		2.5		1.9	
295+79 TO 296+53	20' + BRIDGE + 20'	36	74	296					32.9	296		0.2	1	12.4	24.9		2.8			
296+53 TO 296+83	TRANSITION	36	30	120						13.3	120	0.1	0.4	5	10.1		1.1		0.9	
296+83 TO 299+13		36 to 25	230	779.4				779.4				0.5	2.8	32.7	65.5		21.5		6.6	
299+13 TO 302+16		24	303	808				808				0.5	3.1	33.9	67.9		28.3		8.6	
302+16 TO 303+86	RT TURN LN	36	170	680				680				0.4	2.2	28.6	57.1		6.4		4.8	
303+86 TO 306+16	RT TURN LN	36 to 25	230	779.4				779.4				0.5	2.8	32.7	65.5		21.5		6.6	
306+16 TO 316+25		24	1009	2690.7				2690.7				1.7	10.3	113	226		94.2		28.8	
316+25 TO 316+55	BUTT JOINT	24	30	80	80	33.3	37.8					0.1	0.3	1.7	6.7		2.8		0.9	
316+55 TO 318+09	GAP BRIDGE																		0	
318+09 TO 318+19	BUTT JOINT	24	10	26.7	26.7	11.1	37.8			26.7	11.1	0.1	0.1		2.2		0.9		0.3	
318+19 TO 318+80.74	STA EQ	24	61.74	164.6						164.6	68.6	0.1	0.5		13.8		5.8		1.8	
319+00.64 TO 357+16		24	3815.36	10174.3						10174.3	4239.3	5.8	28.8		854.6		356.1		108.7	
MEDIAN IL 116																				
76+57 TO 76+87	BUTT JOINT	var	30	43.3		43.3	14.4							0.9	1.8					
76+87 TO 83+36		var	649	1406.2				1406.2				0.6	2.8	59.1	118.1					
83+36 TO 85+70	EB LTL	1 to 12	234	676				676	0			0.3	1.4	28.4	56.8					
85+70 TO 88+50	EB LTL	12	280	808.9				808.9	0			0.4	1.6	34	67.9					
88+50 TO 89+43	INTERSECTION	26	93	268.7				268.7				0.2	0.5	11.3	22.6					
89+43 TO 92+23	WB LTL	12	280	808.9				808.9	0			0.4	1.6	34	67.9					
92+23 TO 94+56	WB LTL	1 to 12	233	673.1				673.1	0			0.3	1.3	28.3	56.5					
94+56 TO 96+00	PAVED MEDIAN	26	144	416				416				0.2	0.8	17.5	34.9					
96+00 TO 104+87	GRASS	26	887	0					788.4			0.4	1.6					111.8	44.9	
104+87 TO 106+08	X-OVER	26	121	278.7				278.7				0.2	0.6	11.7	23.4					
106+08 TO 117+46	GRASS	26	1138	0					1011.6			0.5	2					127.5	57.7	
117+46 TO 118+70	X-OVER	26	124	278.7				278.7				0.2	0.6	11.7	23.4					
118+70 TO 119+45	GRASS	26	75	0					66.7			0.1	0.1					8.4	3.8	
119+45 TO 121+75	EB LTL	1 to 12	230	166.1				166.1	204.4			0.2	0.7	7	14			31.4	13.1	
121+75 TO 123+70	EB LTL	12	195	260				260	173.3			0.2	0.9	10.9	21.8			71	11.1	
123+70 TO 124+79	INTERSECTION	26	109	401.6				401.6				0.2	0.8	16.9	33.7					
124+79 TO 131+79	GRASS	26	700	0					622.2			0.3	1.2					78.4	39.9	
131+79 TO 133+05	X-OVER	26	126	297.6				297.6				0.2	0.6	12.5	25					
PAGE TWO SUBTOTALS					106.7	87.7		40568.8	2942.1	11045.6	4319							1381.3	428.5	
PAGE TWO TOTALS							194.4	90	43510.9	15364.6		32.4	176.5	1735.1	4343.9	0		1809.8		606.3

10IRS-3; 102RS-4; 103RS-4; 104RS-7

FILE NAME = j1116.dgn

USER NAME = hudelsonme
 PLOT SCALE = 100.0000 / IN.
 PLOT DATE = 1/29/2018

DESIGNED -
 DRAWN -
 CHECKED -
 DATE -

REVISED -
 REVISED -
 REVISED -
 REVISED -

**STATE OF ILLINOIS
 DEPARTMENT OF TRANSPORTATION**

SCHEDULE OF QUANTITIES

SCALE: SHEET NO. OF SHEETS STA. TO STA.

F.A.P. RTE.	SECTION	COUNTY	TOTAL SHEETS	SHEET NO.
673	**		60	14
		TAZE/WOOD		CONTRACT NO. 68920
		ILLINOIS FED. AID PROJECT		

RESURFACING TABLE (7 OF 7) - TOTALS															
LOCATION	HOT-MIX ASPHALT REMOVAL BUTT JOINT		TEMPORARY RAMP	HOT-MIX ASPHALT REMOVAL 3/4"		HOT-MIX ASPHALT REMOVAL 1 1/2"		POLYMERIZED BITUMINOUS MATERIAL PRIME COAT	AGGREGATE PRIME COAT	POLYMERIZED LEVELING BINDER (MACH METH) IL-4.75 N50 3/4"	POLYMERIZED HOT-MIX ASPHALT SURFACE CSE MIX "E", N70 1 1/2"	INCIDENTAL HOT-MIX ASPHALT SURFACING 1 1/2"	HOT-MIX ASPHALT SHOULDERS		AGGREGATE SHOULDER TYPE B
	RDWY	SHLDR		RDWY	SHLDR	RDWY	SHLDR						11/2"	2 1/4"	
	SQ YD	SQ YD		SQ YD	SQ YD	SQ YD	SQ YD						TON	TON	
TAZEWELL COUNTY															
PAGE ONE SUBTOTALS	286.7	111		100589	128.8	12295.1	4246.9							3699.8	0
PAGE ONE TOTALS	377.7		151.2	100717.4		16542		69	415.4	4248.8	9504.4	0	3699.8		1150.3
PAGE TWO SUBTOTALS	106.7	87.7		40568.8	2942.1	11045.6	4319							1381.3	428.5
PAGE TWO TOTALS	194.4		90	43510.9		15364.6		32.4	176.5	1735.1	4343.9	0	1809.8		606.3
PAGE THREE SUBTOTALS	0	0		11689.5	14719.1	595.5	0							0	1899.6
PAGE THREE TOTALS	0		0	26408.6		595.5		12.6	54.1	490.9	982	0	1899.6		964.3
PAGE FOUR SUBTOTALS	2735.2	199.8		12833.4	720	2612.2	5747.1							699.7	0
PAGE FOUR TOTALS	2935		978.4	13553.4		8359.3		13.9	64.8	600	714.1	870.3	699.7		65.2
TAZEWELL COUNTY SUBTOTALS	3109	399		165680	18510	26548	14313							5781	2328
TAZEWELL COUNTY TOTALS	3508		1220	184190		40861		128	711	7075	15544	870	8109		2786
WOODFORD COUNTY															
PAGE FIVE SUBTOTALS	53.4	22.2		0	0	111421	58473.9							5059.2	0
PAGE FIVE TOTALS	75.6		75.6	0		169894.8		70.6	342.6	0	9364	0	5059.2		1073.1
PAGE SIX SUBTOTALS	829.6	22.2		0	0	12005.4	12345.9							1037.3	0
PAGE SIX TOTALS	851.8		851.8	0		24351.3		11.7	50.1	0	527.8	550.2	1037.3		0
WOODFORD COUNTY SUBTOTALS	883	44		0	0	123426	70820							6097	0
WOODFORD COUNTY TOTALS	927		927	0		194246		82	393	0	9892	550	6097		1073
GRAND TOTALS															
COMBINED SUBTOTALS	3992	443		165680	18510	149974	85133							11878	2328
COMBINED TOTALS TOTALS	4435		2147	184190		235107		210	1104	7075	25436	1420	14206		3859

PRIME COAT APPLICATION RATES		
SURFACE TYPE	BITUMINOUS PRIME COAT	AGGREGATE PRIME COAT
	(GAL/SQ YD)	(LB/SQ YD)
ON COLD MILLED SURFACE	0.1	4
EXISTING PAVEMENT	0.05	4
FOG COAT ON NEW BINDER	0.03	2
0.004 TONS PER GALLON FOR BITUMINOUS PRIME COAT		

HMA AND COARSE AGGREGATE APPLICATION RATES	
HMA SURFACE AND BINDER	112 LB/SQ YD IN
ALL OTHER HMA	112 LB/SQ YD IN
COARSE AGGREGATE	2.05 TONS/CU YD

MATERIAL TRANSFER DEVICE	
LOCATION	TONS
WOODFORD COUNTY MAINLINE SURFACE	8719
TAZEWELL COUNTY MAINLINE SURFACE	13287
TOTAL	22006

MOBILIZATION	
LOCATION	L SUM
JOBSITE	1
TOTAL	1

FLEXIBLE DELINEATORS	
LOCATION	EACH
IL 116 MEDIAN AT SPRING CREEK	38
TOTAL	38

CONSTRUCTING TEST STRIP	
LOCATION	EACH
JOBSITE	2
TOTAL	2

ENGINEERING FIELD OFFICE, TYPE A	
LOCATION	CAL MO
JOBSITE	5
TOTAL	5

RAISED REFLECTIVE PAVEMENT MARKER REMOVAL	
LOCATION	EACH
SPRING CREEK	1498
TOTAL	1498

TRAFFIC CONTROL SURVEILLANCE	
LOCATION	CAL DA
JOBSITE	40
TOTAL	40

CHANGEABLE MESSAGE SIGNS	
LOCATION	CAL MO
JOBSITE - 4 SIGNS	20
TOTAL	20

FILE NAME = 11116.dgn	USER NAME = hudeisonme	DESIGNED -	REVISED -
		DRAWN -	REVISED -
	PLOT SCALE = 100.0000 "/ IN.	CHECKED -	REVISED -
	PLOT DATE = 1/29/2010	DATE -	REVISED -

STATE OF ILLINOIS
DEPARTMENT OF TRANSPORTATION

SCHEDULE OF QUANTITIES

SCALE: SHEET NO. OF SHEETS STA. TO STA.

F.A.P. RTE. 673	SECTION **	COUNTY TAZE/WOOD	TOTAL SHEETS 60	SHEET NO. 19
CONTRACT NO. 68920			ILLINOIS FED. AID PROJECT	

** 101RS-3; 102RS-4; 103RS-4; 104RS-7

PAVEMENT MARKING TABLE (1 OF 3)

LOCATION	PERMANENT AND TEMPORARY PAVEMENT MARKINGS														PAVEMENT MARKING REMOVAL SQ FT	PAVEMENT MARKING TAPE TYPE III 4" FOOT	SHORT TERM PAVEMENT MARKING (2 APPS) FOOT	WORK ZONE PAVEMENT MARKING REMOVAL SQ FT
	URETHANE										PREFORMED PLASTIC		RAISED REFLECTIVE PAVEMENT MARKERS					
	4" WHITE	4" YELLOW SINGLE	4" YELLOW DOUBLE	8" WHITE SOLID	8" WHITE SKIP	12" WHITE DIAG	12" YELLOW DIAG	24" WHITE STOP BAR	LETTERS AND SYMBOLS	6" WHITE CENTERLINE	LETTERS AND SYMBOLS	1-WAY CRYSTAL	1-WAY AMBER					
	FOOT	FOOT	FOOT	FOOT	FOOT	FOOT	FOOT	FOOT	SQ FT	FOOT	SQ FT	EACH	EACH					
TAZEWELL COUNTY																		
EASTBOUND																		
Mainline	28048	28048						120		7012		351					9293	3097.7
Truck Lane and Tapers				1076	75.8												104	34.7
Left Turn Lanes																		
Access Road 4			498	250			154	12	46.8			7	7					
Access Road 5			338	207			173	12	46.8			6	5					
Mariner's Way				202				12	31.2			6						
Marina				270				12	46.8			7						
Access Road 8				218				12	46.8			6						
Upper Free Bridge Road				205				12	31.2			6						
IL 26				670	39	61		12	46.8			17						
Spring Creek Road				190				12	31.2			5						
Access Road 10				140				12	31.2			4						
Fauber Lane				261				12	46.8			7						
Upper Spring Bay Road				261				12	46.8			7						
Right Turn Lanes																		
Highview Road				215				18	46.8			6						
Access Road 6				215				18	46.8			6						
Centennial Drive				170				18	31.2			5						
Ramp to EB US 24				468	61	108						12						
Ramp from EB US 24				1196	112													
Ramp from WB US 24				1672	173	201												
Grosenbach Road				412		95			46.8			5						
Spring Creek Road				185					31.2			5						
Ronald Road				150					31.2			4						
WESTBOUND																		
Mainline	28048	28048						120		7012		351					9293	3097.7
Left Turn Lanes																		
Highview Road			488	280			154	12	46.8			7	7					
Access Road 6			392	214			191	12	46.8			6	5					
Centennial Drive (Acceleration Ln)			354	823								18	5					
Centennial Drive			260	481				12				10	4					
Grosenbach Road				210				12	46.8			6						
Spring Creek Road				132				12	31.2			4						
Ronald Road				210				12	46.8			6						
Right Turn Lanes																		
Access Road 4				251				18	46.8			7						
Access Road 5				248					46.8			7						
Mariner's Way				231				18	46.8			6						
Marina				210				18	46.8			6						
Ramp to WB US 24				524	85	111						14						
Ramp from WB US 24				544	38													
Ramp to EB US 24				476	38	94						12						
Access Road 8				210				18	46.8			6						
Upper Free Bridge Road				210					46.8			6						
IL 26 (Acceleration Ln)				854	142	130												
IL 26				210					46.8			6						
Spring Creek Road				210					46.8			6						
Access Road 10				210					46.8			6						
PAGE ONE SUBTOTALS	56096	56096	2330	15371	763.8	800	672					962	33					
PAGE ONE TOTALS		114522		16134.8		1472		570	1326	14024	0	995		0	0		18690	6230.1

FILE NAME = 1116.dgn	USER NAME = hudeisonne	DESIGNED -	REVISED -
		DRAWN -	REVISED -
		CHECKED -	REVISED -
		DATE -	REVISED -

**STATE OF ILLINOIS
DEPARTMENT OF TRANSPORTATION**

SCHEDULE OF QUANTITIES

SCALE: SHEET NO. OF SHEETS STA. TO STA.

F.A.P. RTE. 673	SECTION ..	COUNTY TAZE/WOOD	TOTAL SHEETS 60	SHEET NO. 20
CONTRACT NO. 68920			ILLINOIS FED. AID PROJECT	

.. 101RS-3; 102RS-4; 103RS-4; 104RS-7

PAVEMENT MARKING TABLE (2 OF 3)

LOCATION	PERMANENT AND TEMPORARY PAVEMENT MARKINGS										PAVEMENT MARKING REMOVAL	PAVEMENT MARKING TAPE TYPE III 4"	SHORT TERM PAVEMENT MARKING (2 APPS)	WORK ZONE PAVEMENT MARKING REMOVAL			
	URETHANE					PREFORMED PLASTIC		RAISED REFLECTIVE PAVEMENT MARKERS									
	4" WHITE FOOT	4" YELLOW SINGLE FOOT	4" YELLOW DOUBLE FOOT	8" WHITE SOLID FOOT	8" WHITE SKIP FOOT	12" WHITE DIAG FOOT	12" YELLOW DIAG FOOT	24" WHITE STOP BAR FOOT	LETTERS AND SYMBOLS SQ FT	6" WHITE CENTERLINE FOOT					LETTERS AND SYMBOLS SQ FT	1-WAY CRYSTAL EACH	1-WAY AMBER EACH
TAZEWELL COUNTY																	
SN 090-0110 Stage One														124	2470		823.3
SN 090-0110 Stage Two															2470		823.3
SIDE ROADS																	
Access Road 4	254		254	240			70		40	41.6							
Highview Road	144		144	196			62		34	41.6							
Access Road 5	128		128	140			50		32	41.6							
Mariner Way	188		188	144			50		40	41.6							
Access Road 6	156		156	136			48		36	41.6							
Centennial Drive																	
Marina	44		44	270			89		52	72.8							
Access Road 8	128		128	183			75		40	41.6							
Upper Free Bridge Road	160		160	144			50		40	41.6							
Grosenbach Road	174		174	132			33		33	41.6							
IL 26																	
Spring Creek Road (LT)	106		106						15								
Spring Creek Road (RT)	86		86						15								
Access Road 10	92		92	133			25		18	46.8							
Ronald Road	30																
Fauber Lane	106		106														
Ten Mile Creek Road	144		144														
Upper Spring Bay Road	52		52														
YIELD BARS																	
3 in median at Spring Creek Road														178.8			
2 in median at Ten Mile Creek Road														119.2			
MEDIAN DELINIATION																	
In median 76+57 to 83+36, 94+56 to 96+00			1646						1554						21		
In median at Spring Creek Road			764						375						10		
PAGE TWO SUBTOTALS	1992	0	4372	1718	0	552	1929						0	31			
PAGE TWO TOTALS		6364		1718		2481	395	452.4	0	298			31	124	4940	0	1646.6
TAZEWELL COUNTY SUBTOTALS	58088	56096	6702	17089	763.8	1352	2601						962	64			
TAZEWELL COUNTY TOTALS		120886		17852.8		3953	965	1778.4	14024	298			1026	124	4940	18690	7877

LOCATION	PROTECTIVE COAT	BRIDGE WEARING SURFACE REMOVAL	BRIDGE DECK GROOVING	WIDTH RESTRICTION SIGNING	CONCRETE BRIDGE DECK SCARIFICATION 1/2"	BRIDGE DECK LATEX CONCRETE OVERLAY 2 1/4"	TEMPORARY CONCRETE BARRIER	RELOCATE TEMPORARY CONCRETE BARRIER	IMPACT ATTENUATORS TEMPORARY (NON-REDIRECTIVE) TEST LEVEL 3	IMPACT ATTENUATORS RELOCATE (NON-REDIRECTIVE) TEST LEVEL 3
	SQ YD	SQ YD	SQ YD	L SUM	SQ YD	SQ YD	FOOT	FOOT	EACH	EACH
SN 090-0110 (WB)	659	659	659	1	659	659	321	321	1	1
TOTALS	659	659	659	1	659	659	321	321	1	1

FRAMES AND GRATES TO BE ADJUSTED	
LOCATION	EACH
80+61 MEDIAN	1
83+83 MEDIAN	1
96+50 MEDIAN	1
124+82 MEDIAN	1
144+20 MEDIAN	1
187+00 MEDIAN	2
189+00 MEDIAN	1
190+75 MEDIAN	2
191+75 MEDIAN	2
192+40 MEDIAN	1
295+75 MEDIAN	1
HIGHVIEW RD.	2
TOTAL	16

PAVEMENT MARKING TABLE (3 OF 3)

PERMANENT AND TEMPORARY PAVEMENT MARKINGS

LOCATION	URETHANE										PREFORMED PLASTIC		RAISED REFLECTIVE PAVEMENT MARKERS		PAVEMENT MARKING REMOVAL SQ FT	PAVEMENT MARKING TAPE TYPE III 4" FOOT	SHORT TERM PAVEMENT MARKING (2 APPS) FOOT	WORK ZONE PAVEMENT MARKING REMOVAL SQ FT
	4" WHITE FOOT	4" YELLOW SINGLE FOOT	4" YELLOW DOUBLE FOOT	8" WHITE SOLID FOOT	8" WHITE SKIP FOOT	12" WHITE DIAG FOOT	12" YELLOW DIAG FOOT	24" WHITE STOP BAR FOOT	LETTERS AND SYMBOLS SQ FT	6" WHITE CENTERLINE FOOT	LETTERS AND SYMBOLS SQ FT	1-WAY CRYSTAL EACH	1-WAY AMBER EACH					
WOODFORD COUNTY																		
EASTBOUND																		
Mainline	18848	18848						72				4712		236			6141	2047
Truck Lane and Tapers				3384	75													
Left Turn Lanes																		
Byerly Hills Drive								12				46.8						
Parkway Drive								12				46.8						
St. Francis Drive								12				46.8						
Far Hills Drive								12				46.8						
Woodland Knolls Road								12				46.8						
Fandel Road								12				46.8						
Timberlan Road (LT)								12				46.8						
Arbor Vitae								12				46.8						
Right Turn Lanes																		
Upper Ten Mile Creek Road								18				46.8						
Fandel Road								18				46.8						
Timberlan Road (RT)												46.8						
Schmitt Lane								18				46.8						
WESTBOUND																		
Mainline	18848	18848						72				4712		236			6141	2047
Left Turn Lanes																		
Upper Ten Mile Creek Road								12				46.8						
Fandel Road								12				46.8						
Timberlan Road								12				46.8						
Schmitt Lane								12				46.8						
Right Turn Lanes																		
Woodland Knolls								18				46.8						
Fandel Road								18				46.8						
Arbor Vitae								18				46.8						
SIDE ROADS																		
Hoppe Lane (LT & RT)																		
Byerly Hills Drive																		
Newman Road																		
Parkway Drive	40		40															
Access Road 13	40		40															
St. Francis Lane	50		50															
Far Hills Road	348		328	76				39	41.6									
Maple Lane (LT)	131																	
Maple Lane (RT)	158																	
Woodland Knolls Drive	181		70	92		34		27	41.6									
Upper Ten Mile Creek Road	224		86	43				33	41.6									
Fandel Road (LT)	181		98	44				25	41.6									
Fandel Road (RT)	260		124	61				24	41.6									
Timberlan Road	160		104															
Arbor Vitae	179		116	54				24	41.6									
Schmitt Lane	187		98	48				24	41.6									
CROSS WALKS																		
Across IL 116 at Woodland Knolls/Upper Ten Mile	238							212										
Across Fandel Road	144							184										
Across IL 116 at Fandel Road	171							279										
Across IL 116 at Arbor Vitae/Schmitt Ln	238							212										
WOODFORD COUNTY SUBTOTALS	40626	37696	1154	3802	75	921	0					472	0					
WOODFORD COUNTY TOTALS		79476		3877		921	592	1180.4	9424	0		472	0		0		12282	4094
TAZEWELL COUNTY SUBTOTALS	58088	56096	6702	17089	763.8	1352	2601					962	64		124		4940	18690
TAZEWELL COUNTY TOTALS		120886		17852.8		3953	965	1778.4	14024	298		1026						7877
COMBINED SUBTOTALS	98714	93792	7856	20891	838.8	2273	2601					1434	64					
COMBINED TOTALS		200362		21729.8		4874	1557	2958.8	23448	298		1498			124		4940	30972

** 101RS-3; 102RS-4; 103RS-4; 104RS-7

FILE NAME = 11116.dgn	USER NAME = hudelsonne	DESIGNED -	REVISED -
		DRAWN -	REVISED -
		CHECKED -	REVISED -
		DATE -	REVISED -

STATE OF ILLINOIS
DEPARTMENT OF TRANSPORTATION

SCHEDULE OF QUANTITIES

SCALE: SHEET NO. OF SHEETS STA. TO STA.

F.A.P. RTE. 673	SECTION **	COUNTY TAZE/WOOD	TOTAL SHEETS 60	SHEET NO. 22
CONTRACT NO. 68920			ILLINOIS FED. AID PROJECT	

STEEL PLATE BEAM GUARDRAIL REMOVAL		
LOCATION	SINGLE RAIL	DOUBLE RAIL
	FT	FT
TAZEWELL COUNTY		
EASTBOUND IL 116		
RT 124+38 TO 127+05	292	
RT 127+52 TO 132+22	470	
RT 152+60 TO 155+91	331	
RT 179+50 TO 180+76	126	
RT 192+60 TO 193+76	116	
RT 218+00 TO 219+78	178	
LT 224+78 TO 227+10	232	
RT 226+00 TO 226+93	93	
LT 232+80 TO 234+20	140	
RT 232+90 TO 233+87	97	
LT 239+00 TO 242+06	306	
RT 345+00 TO 345+50	50	
WESTBOUND IL 116		
LT 218+37 TO 219+90	153	
RT 225+45 TO 227+90	245	
LT 233+59 TO 235+00	141	
RT 234+11 TO 235+00	89	
MEDIAN IL 116		
Upper Spring Bay Rd / IL 116 south		32
331+68 TO 332+00		32
TOTAL TAZEWELL COUNTY	3059	64
WOODFORD COUNTY		
MEDIAN IL 116		
Hoppe Ln / IL 116 south		32
Hoppe Ln / IL 116 north		32
Byerly Hills / IL 116 south		32
Byerly Hills / IL 116 north		32
Parkway Drive / IL 116 north		32
St. Francis / IL 116 south		32
St. Francis / IL 116 north		32
Far Hills Drive / IL 116 south		32
Far Hills Drive / IL 116 north		32
Maple Lane / IL 116 south		32
Maple Lane / IL 116 north		32
TOTAL WOODFORD COUNTY	0	352
TOTAL	3059	416

GUARDRAIL TABLE									
LOCATION	STEEL PLATE BEAM GUARD RAIL TYPE A	STEEL PLATE BEAM GUARD RAIL ATTACHED TO STRUCTURES	TRAFFIC BARRIER TERMINAL TYPE 1 TANGENT SPECIAL	TRAFFIC BARRIER TERMINAL TYPE 2	TRAFFIC BARRIER TERMINAL TYPE 6	IMPACT ATTENUATORS PARTIALLY REDIRECTIVE TEST LEVEL 3	TERMINAL MARKER DIRECT APPLIED	GUARDRAIL AGGREGATE EROSION CONTROL	GUARDRAIL MARKERS TYPE A
	FOOT	FOOT	EACH	EACH	EACH	EACH	EACH	TON	EACH
TAZEWELL COUNTY									
EASTBOUND IL 116									
RT 124+42.5 TO 127+05	200		1	1			1	51.9	3
RT 127+52 TO 132+27	412.5		1	1			1	93.9	6
RT 177+58 TO 180+5.5	225		1	1			1	56.8	3
RT 192+60 TO 193+35	12.5		1	1			1	14.8	2
RT 216+79 TO 219+54	187.5	25	1	1			1	54.3	3
LT 222+50 TO 226+87.5	375		1	1			1	86.5	5
RT TO 225+99 TO 226+93			1		1		1	18.6	2
LT 231+67 TO 234+04.5	175		1	1			1	46.9	3
RT 233+42+93 TO 233+87			1		1		1	18.6	2
LT 237+85 TO 240+22.5	162.5	12.5	1	1			1	46.9	3
RT 345+00 TO 345+50			1				1	9.9	2
WESTBOUND IL 116									
LT 218+81.5 TO 221+19	175		1	1			1	46.9	3
RT 225+67.5 TO 229+30	300		1	1			1	71.6	4
LT 233+87.5 TO 236+62.5	212.5		1	1			1	54.3	3
RT 234+06 TO 235+00			1		1		1	18.6	2
MEDIAN IL 116									
Upper Spring Bay Rd / IL 116 south						1			
331+68 TO 332+00						1			
TOTAL TAZEWELL COUNTY	2437.5	37.5	15	11	3	2	15	690.5	46
WOODFORD COUNTY									
MEDIAN									
Hoppe Ln / IL 116 south						1			
Hoppe Ln / IL 116 north						1			
Byerly Hills / IL 116 south						1			
Byerly Hills / IL 116 north						1			
Parkway Drive / IL 116 north						1			
St. Francis / IL 116 south						1			
St. Francis / IL 116 north						1			
Far Hills Drive / IL 116 south						1			
Far Hills Drive / IL 116 north						1			
Maple Lane / IL 116 south						1			
Maple Lane / IL 116 north						1			
TOTAL WOODFORD COUNTY	0	0	0	0	0	11	0	0	0
TOTAL	2437.5	37.5	15	11	3	13	15	690.5	46

TRAFFIC CONTROL AND PROTECTION STANDARDS				
LOCATION	STANDARD 701421	STANDARD 701423	STANDARD 701411	STANDARD 701701
	L SUM	EACH	EACH	L SUM
JOBSITE	1	1	5	1
TOTAL	1	1	5	1

FILE NAME = s1116.dgn	USER NAME = hudsonme	DESIGNED -	REVISED -
		DRAWN -	REVISED -
	PLOT SCALE = 1/80.0000 "/ IN.	CHECKED -	REVISED -
	PLOT DATE = 1/29/2010	DATE -	REVISED -

**STATE OF ILLINOIS
DEPARTMENT OF TRANSPORTATION**

SCHEDULE OF QUANTITIES

SCALE: SHEET NO. OF SHEETS STA. TO STA.

F.A.P. RTE. 673	SECTION **	COUNTY TAZE/WOOD	TOTAL SHEETS 60	SHEET NO. 23
CONTRACT NO. 68920			ILLINOIS FED. AID PROJECT	

** 101RS-3; 102RS-4; 103RS-4; 104RS-7

Class B Patching Schedule							
Location	Class B Type II Patch 14"	Class B Type III Patch 14"	Class B Type IV Patch 14"	Dowel Bars	Saw Cuts	Tie Bars 3/4"	Pavement Fabric
	Sq Yd	Sq Yd	Sq Yd	Each	Each	Each	Sq Yd
Start of Project to Highview Road							
Eastbound	96.00	74.67	80.00	320.00	948.00	30.00	154.67
Westbound	26.67	42.67	0.00	100.00	276.00	0.00	42.67
Highview Road to Mariner Way							
Eastbound	349.33	0.00	0.00	740.00	1674.00	0.00	0.00
Westbound	152.00	53.33	81.78	460.00	1214.00	20.00	135.11
Mariner Way to Centennial Drive							
Eastbound	338.67	48.00	653.33	900.00	3420.00	245.00	701.33
Westbound	40.00	74.67	53.33	220.00	642.00	20.00	128.00
Centennial Drive to Marina Lane							
Eastbound	48.00	0.00	386.67	160.00	1170.00	145.00	386.67
Westbound	24.00	32.00	0.00	100.00	246.00	0.00	32.00
Marina Lane to IL 26							
Eastbound	320.00	32.00	106.67	880.00	2088.00	40.00	138.67
Westbound	197.33	160.00	0.00	620.00	1548.00	0.00	160.00
IL 26 to Ten Mile Creek / Fauber Lane							
Eastbound	16.00	32.00	0.00	80.00	204.00	0.00	32.00
Westbound	77.33	90.67	0.00	380.00	942.00	0.00	90.67
Ten Mile Creek / Fauber Lane to County Line							
Eastbound	200.00	0.00	0.00	480.00	1026.00	0.00	0.00
Westbound	213.33	0.00	0.00	520.00	1104.00	0.00	0.00
TAZEWELL COUNTY SUB TOTAL							
	2099.00	640.00	1362.00	5960.00	16502.00	500.00	2002.00
County Line to Far Hills Drive							
Eastbound	469.33	32.00	0.00	1180.00	2544.00	0.00	32.00
Westbound	618.67	32.00	0.00	1540.00	3360.00	0.00	32.00
Far Hills Drive to Woodland Knols Drive							
Eastbound	162.67	0.00	0.00	380.00	822.00	0.00	0.00
Westbound	80.00	0.00	0.00	200.00	420.00	0.00	0.00
Woodland Knolls Drive / Upper Ten Mile Creek Rd to End of Project							
Eastbound	338.67	0.00	0.00	760.00	1674.00	0.00	0.00
Westbound	168.00	0.00	0.00	420.00	882.00	500.00	0.00
WOODFORD COUNTY SUB TOTAL							
	1837.00	64.00	0.00	4480.00	9702.00	500.00	64.00
TOTAL							
	3936.00	704.00	1362.00	10440.00	26204.00	1000.00	2066.00

FILE NAME = 11116.dgn	USER NAME = hudeisonne	DESIGNED -	REVISED -
		DRAWN -	REVISED -
		CHECKED -	REVISED -
		DATE -	REVISED -

**STATE OF ILLINOIS
DEPARTMENT OF TRANSPORTATION**

SCHEDULE OF QUANTITIES

SCALE: SHEET NO. OF SHEETS STA. TO STA.

F.A.P RTE. 673	SECTION **	COUNTY TAZE/WOOD	TOTAL SHEETS 60	SHEET NO. 24
CONTRACT NO. 68920				
ILLINOIS FED. AID PROJECT				

** 101RS-3; 102RS-4; 103RS-4; 104RS-7

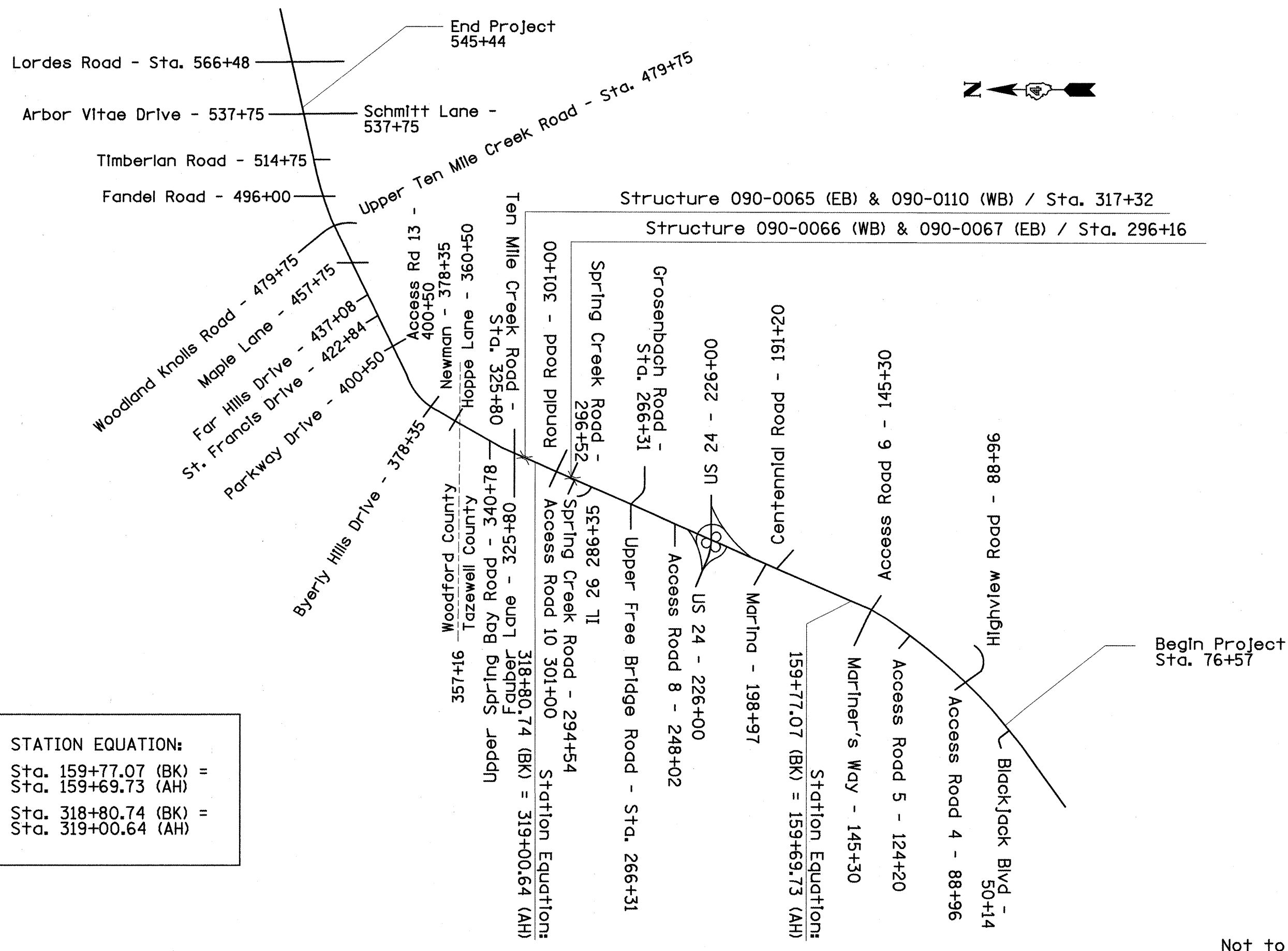

STATION EQUATION:
 Sta. 159+77.07 (BK) =
 Sta. 159+69.73 (AH)
 Sta. 318+80.74 (BK) =
 Sta. 319+00.64 (AH)

Not to Scale

•• 101RS-3; 102RS-4; 103RS-4; 104RS-7

FILE NAME = s1116.dgn	USER NAME = hudeisonme	DESIGNED -	REVISED -	STATE OF ILLINOIS DEPARTMENT OF TRANSPORTATION	LINE DIAGRAM			F.A.P. RTE. 673	SECTION ..	COUNTY	TOTAL SHEETS 60	SHEET NO. 25
	PLOT SCALE = 100.0000' / IN.	CHECKED -	REVISED -					CONTRACT NO. 68920				
PLOT DATE = 1/29/2010	DATE -	REVISED -	SCALE:		SHEET NO.	OF SHEETS	STA.	TO STA.	ILLINOIS FED. AID PROJECT			

MEDIAN DELINIATION AND YIELD BARS AT SPRING CREEK ROAD

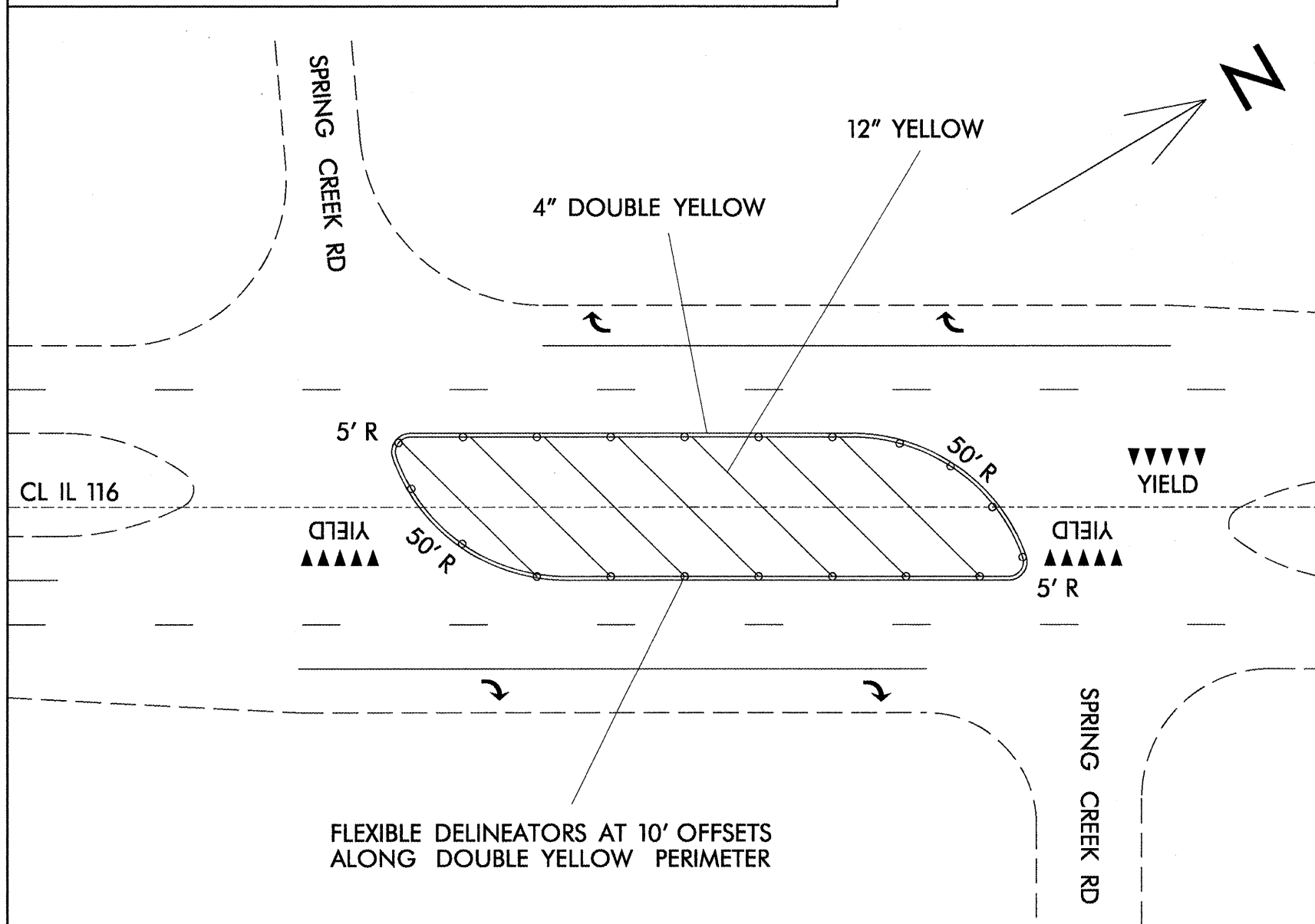

YIELD BARS AT TEN MILE CREEK ROAD

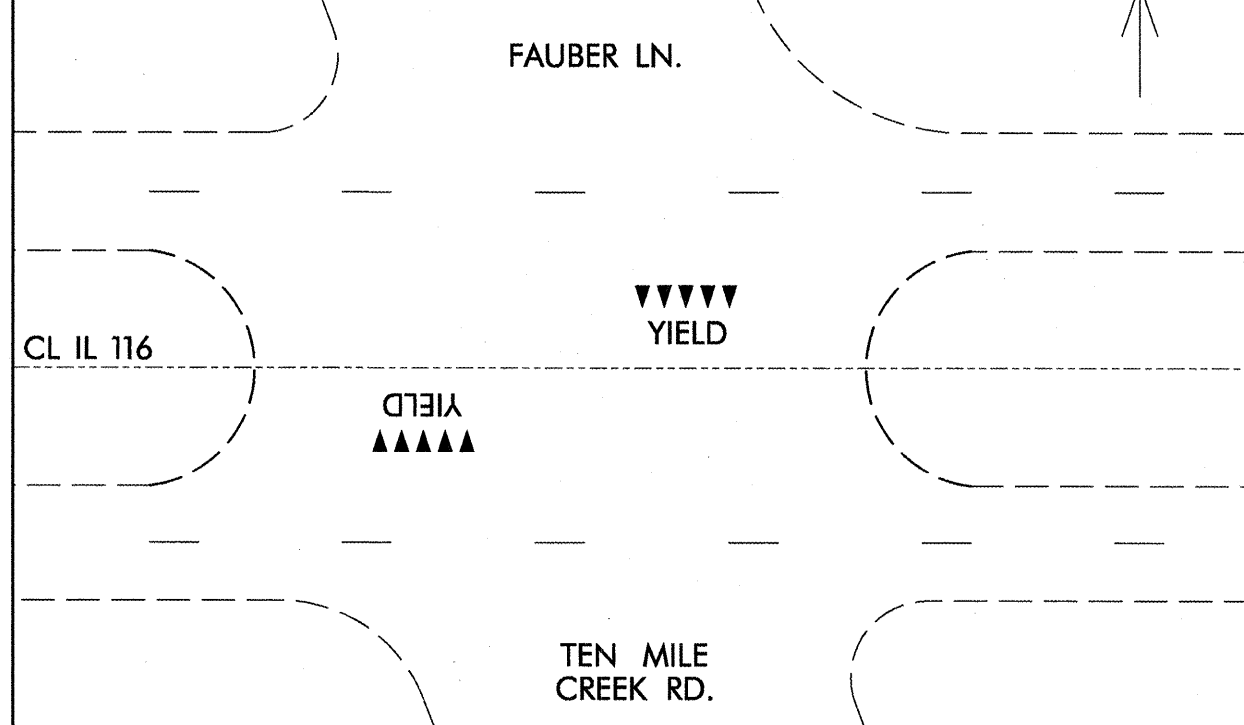

YIELD BAR DETAILS

- 1.) Arrows are isosceles triangles 2' wide by 3' tall
- 2.) large letters used for "YIELD"
- 3.) Yield bars shall be preformed plastic

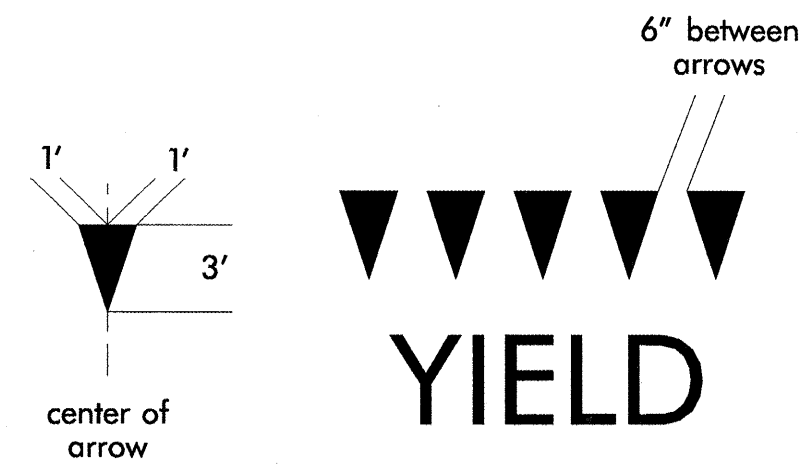

YIELD BAR PLACEMENT (TYPICAL)

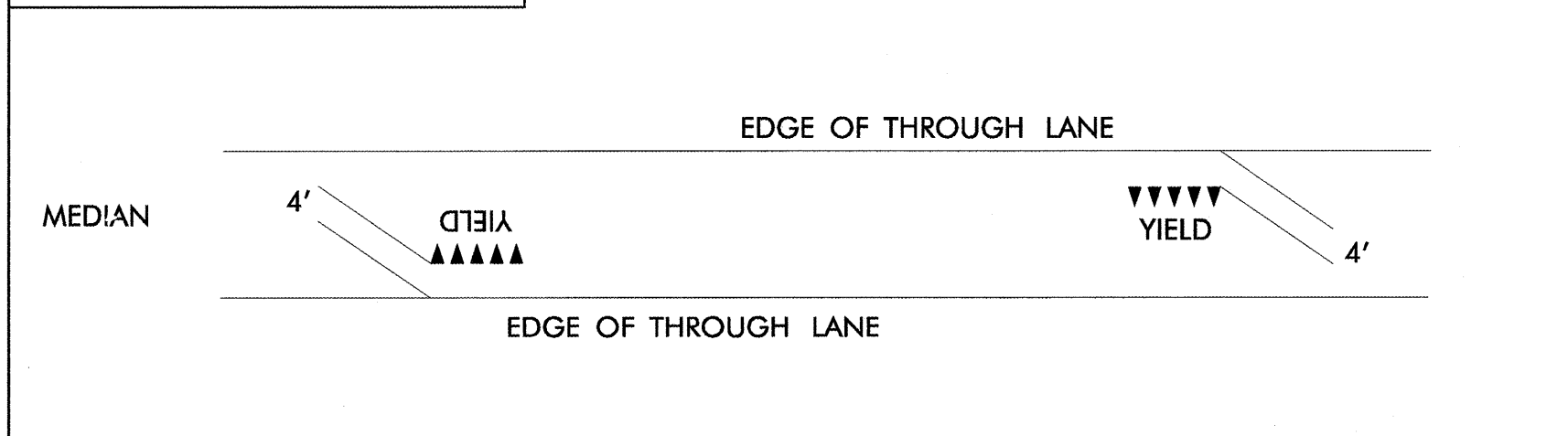

CROSS WALK DETAIL - ACROSS FANDEL RD.
ACROSS IL 116 AT WOODLAND KNOLLS / UPPER TEN MILE
ACROSS IL 116 AT FANDEL RD.
ACROSS IL 116 AT ARBOR VITAE / SCHMITT LN.

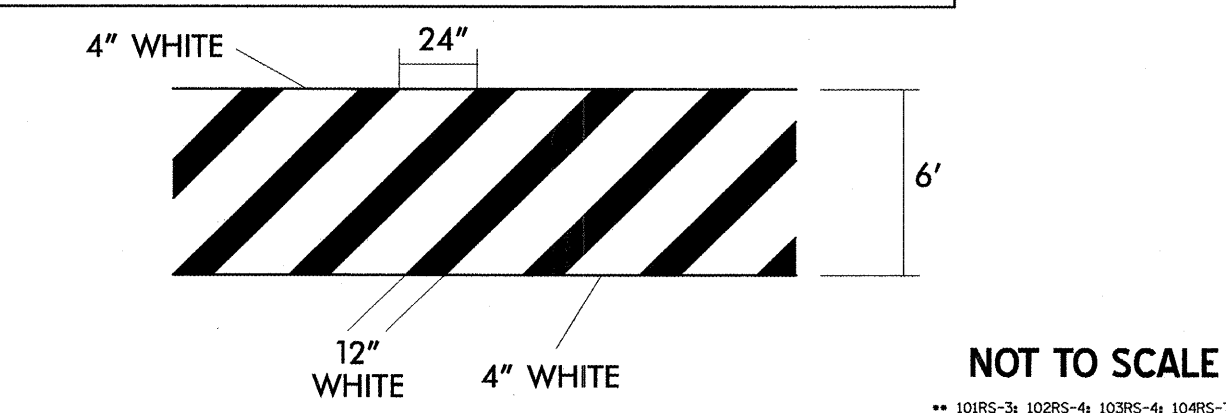

NOT TO SCALE

FILE NAME = s1116.dgn	USER NAME = hudelsonme	DESIGNED -	REVISED -
		DRAWN -	REVISED -
		CHECKED -	REVISED -
		DATE -	REVISED -

STATE OF ILLINOIS
DEPARTMENT OF TRANSPORTATION

PAVEMENT MARKING DETAILS			
SCALE:	SHEET NO.	OF SHEETS	STA. TO STA.

F.A.P. RTE.	SECTION	COUNTY	TOTAL SHEETS	SHEET NO.
673	**	TAZE/WOOD	60	26
CONTRACT NO. 68920				
ILLINOIS FED. AID PROJECT				

** 101RS-3; 102RS-4; 103RS-4; 104RS-7

Roadway

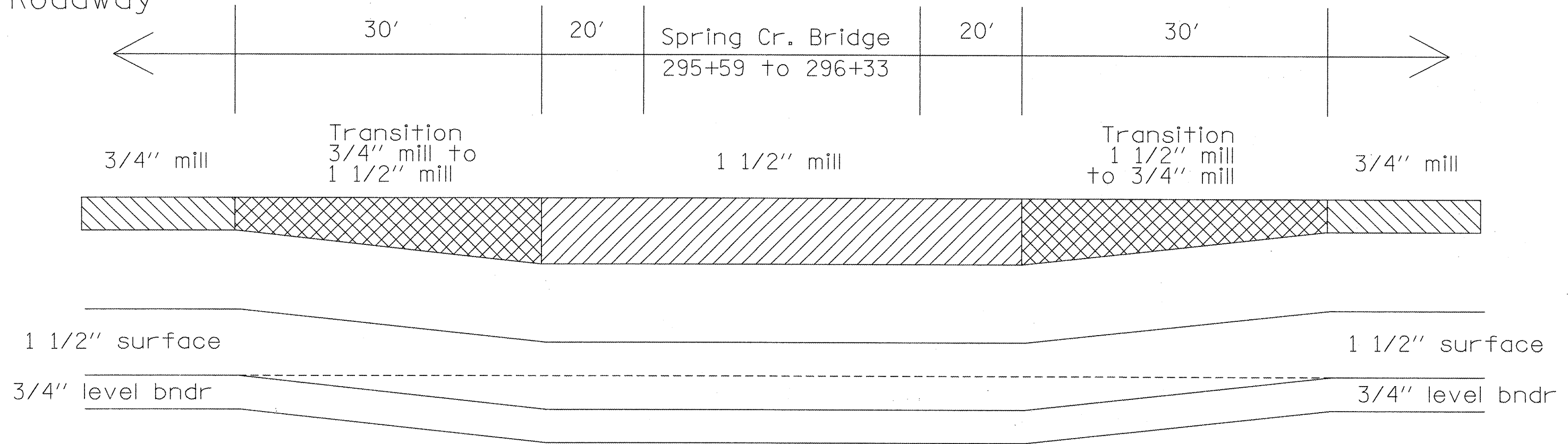

Shoulder

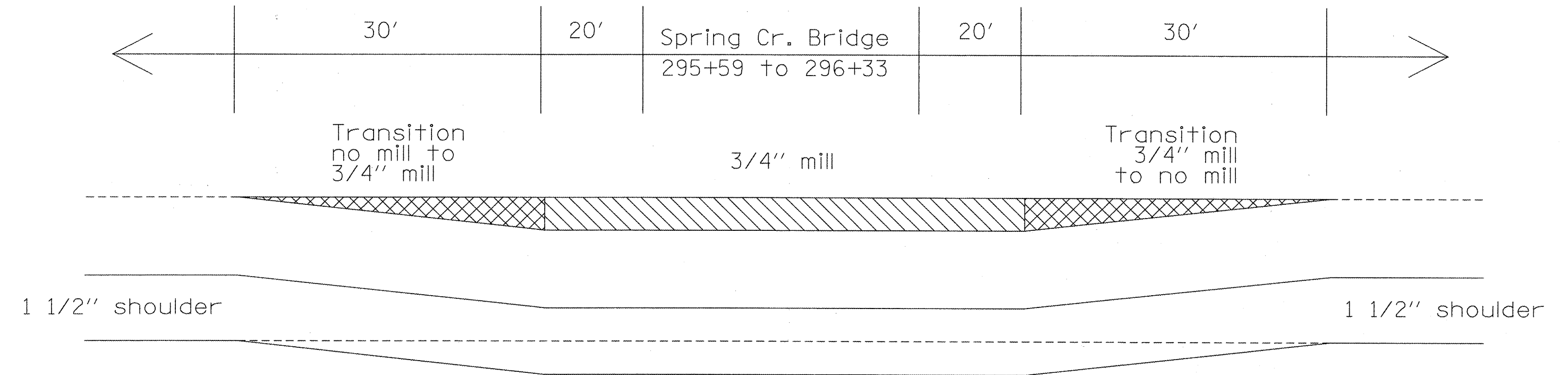

•• 101RS-3; 102RS-4; 103RS-4; 104RS-7

FILE NAME = 11116.dgn	USER NAME = hude1sonme	DESIGNED -	REVISED -
		DRAWN -	REVISED -
	PLOT SCALE = 100.0000' / IN.	CHECKED -	REVISED -
	PLOT DATE = 1/29/2010	DATE -	REVISED -

**STATE OF ILLINOIS
DEPARTMENT OF TRANSPORTATION**

SPRING CREEK BRIDGE MILL & OVERLAY

F.A.P. RTE. 673	SECTION ••	COUNTY TAZE/WOOD	TOTAL SHEETS 60	SHEET NO. 27
CONTRACT NO. 68920				ILLINOIS FED. AID PROJECT

SCALE: SHEET NO. OF SHEETS STA. TO STA.

STATE OF ILLINOIS
DEPARTMENT OF TRANSPORTATION

NOTES

All structural steel shall conform to AASHTO Classification M-270 Gr. 36, unless otherwise noted.
Reinforcement bars shall conform to the requirements of ASTM A 706 Gr 60. See Special Provisions.
Reinforcement bars designated (E) shall be epoxy coated.
Prior to pouring the new concrete deck, all heavy or loose rust, loose mill scale, and other loose or potentially detrimental foreign material shall be removed from the surfaces in contact with concrete. Tightly adhered paint may remain unless otherwise noted. Removal shall be accomplished by methods that will not damage the steel and the cost will be included in the pay item covering removal of the existing concrete.
Plan dimensions and details relative to existing plans are subject to nominal construction variations. The Contractor shall field verify existing dimensions and details affecting new construction and make necessary approved adjustments prior to construction or ordering of materials. Such variations shall not be cause for additional compensation for a change in scope of the work, however, the Contractor will be paid for the quantity actually furnished at the unit price bid for the work.
Existing reinforcement bars extending into the removal area shall be cleaned, straightened and incorporated into the new construction. Any reinforcement bars that are damaged during concrete removal shall be replaced with an approved bar splicer or anchorage system. Cost included with Concrete Removal.
Joint openings shall be adjusted according to Article 520.04 of the Standard Specifications when the deck is poured at an ambient temperature other than 50° F.
The existing structural steel coating contains lead. The Contractor shall take appropriate precautions to deal with the presence of lead on this project.
The deck surface shall have its final finish tined according to Article 420.09(e)(1) of the Standard Specifications. Cost included with Concrete Superstructures.

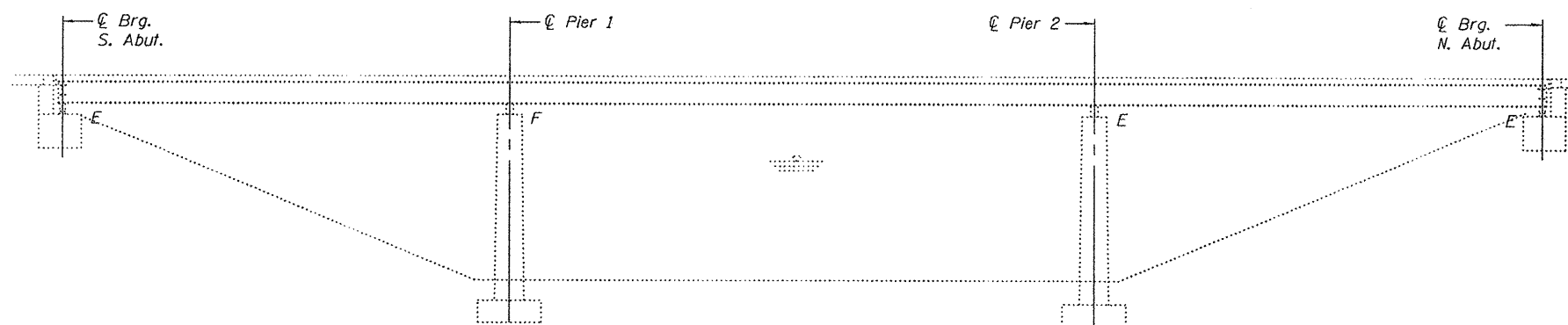

ELEVATION

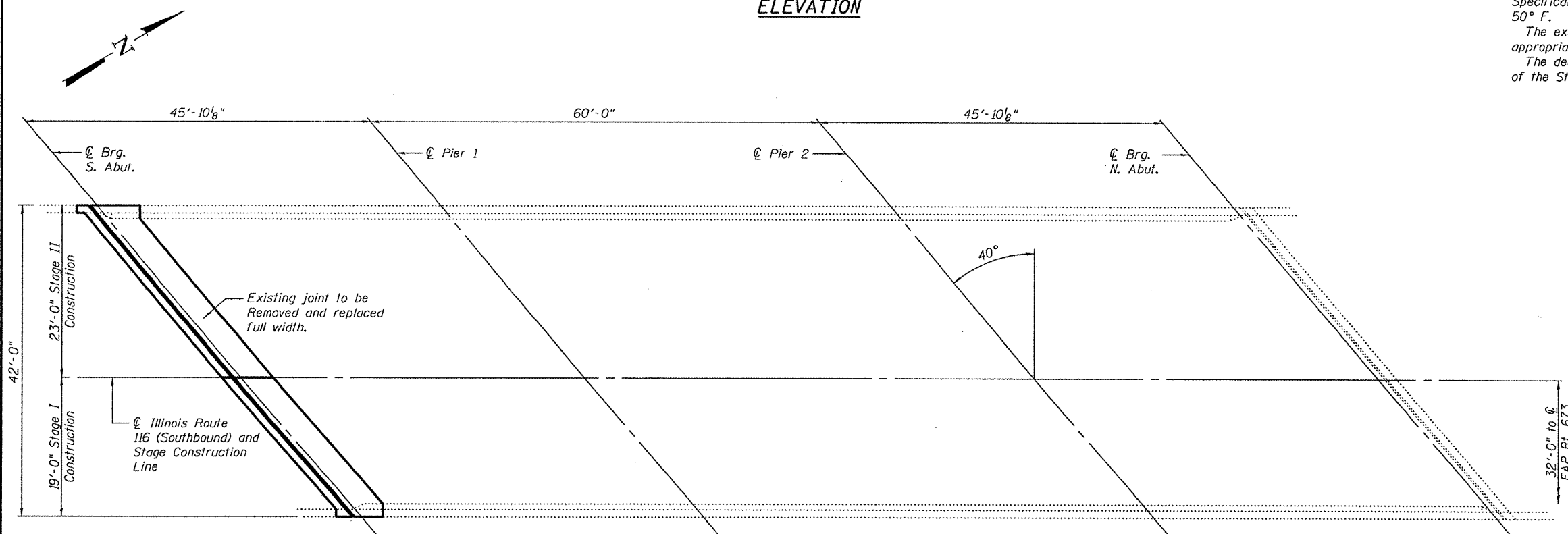

PLAN

BILL OF MATERIAL

ITEM	UNIT	QUANTITY
Concrete Removal	Cu. Yd.	12.3
Concrete Superstructure	Cu. Yd.	12.2
Reinforcement Bars, Epoxy Coated	Pound	1,560
Preformed Joint Strip Seal	Foot	54.5
Bar Splicers	Each	22
Hot-Mix Asphalt Surface Removal (Deck)	Sq. Yd.	659
Bridge Deck Hydroscarification 1/2"	Sq. Yd.	659
Bridge Deck Latex Concrete Overlay, 2 1/4"	Sq. Yd.	659
Bridge Deck Grooving	Sq. Yd.	659
Protective Coat	Sq. Yd.	659

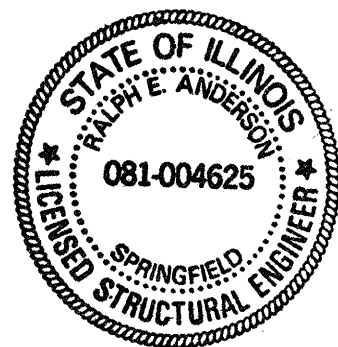

DESIGNED *[Signature]*
CHECKED *[Signature]*
DRAWN Drew Christopher
CHECKED *[Signature]* ISL

March 15, 2010
EXAMINED *[Signature]*
PASSED *[Signature]*
ENGINEER OF BRIDGES AND STRUCTURES

Expires: November 30, 2010

**PLAN AND ELEVATION
IL RTE 116 (SB) OVER
TEN MILE CREEK
SN 090-0110**

SHEET NO.	F.A.P. RTE.	SECTION	COUNTY	TOTAL SHEETS	SHEET NO.
1	673	101RS-3, 102RS-4, 103RS-4, 104RS-7	Tazewell	60	28
				CONTRACT NO.	68920
5 SHEETS		FED. ROAD DIST. NO. ILLINOIS FED. AID PROJECT			

STATE OF ILLINOIS
DEPARTMENT OF TRANSPORTATION

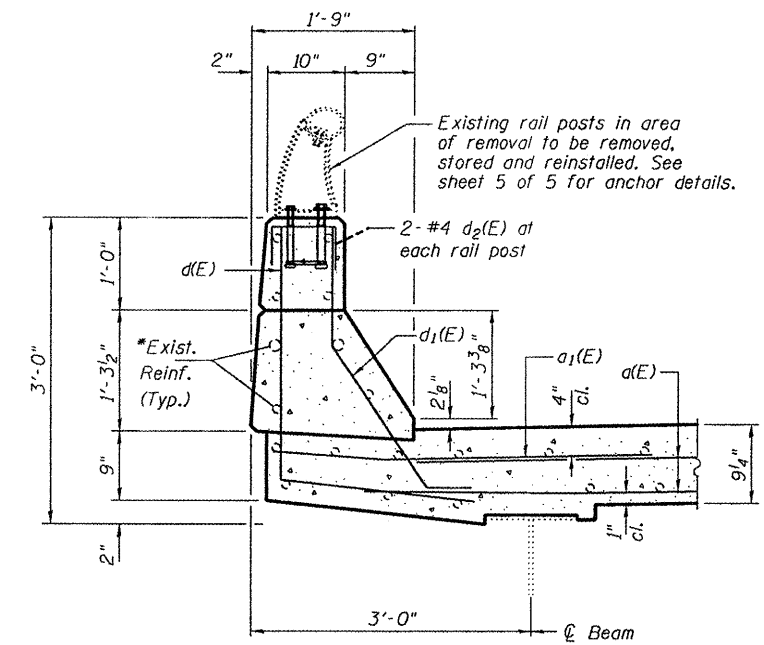
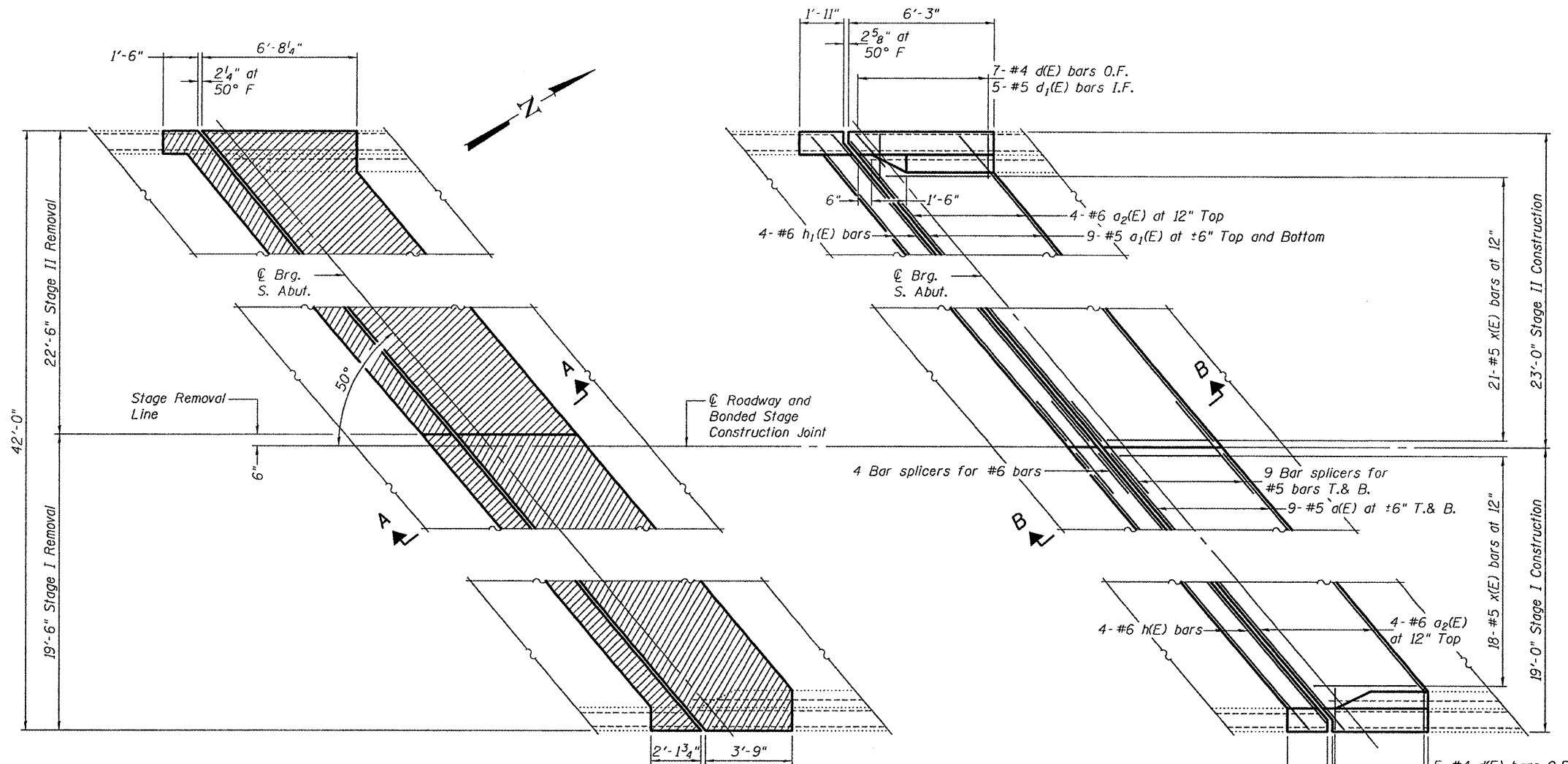

SECTION THRU PARAPET

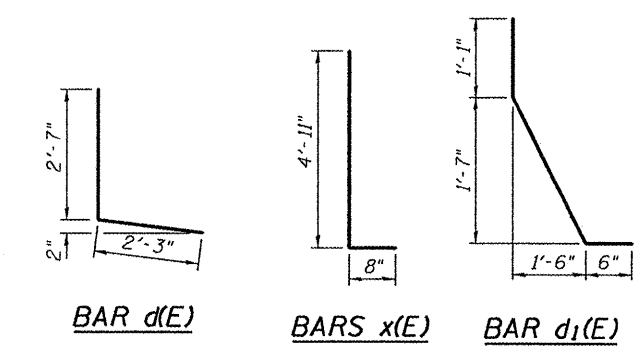

BAR d(E) BARS x(E) BAR d1(E)

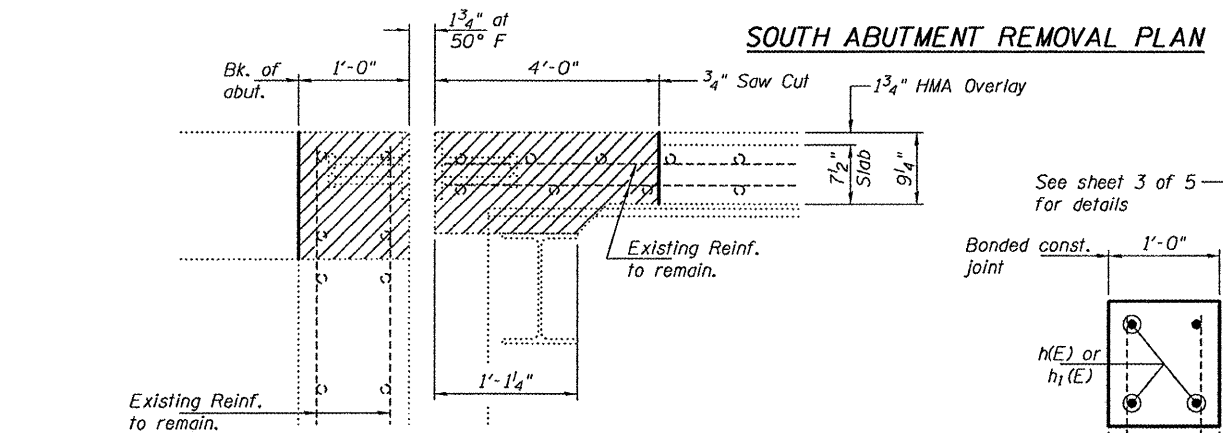

SOUTH ABUTMENT REMOVAL PLAN

SECTION A-A
(Near \bar{C} Roadway)
(Dims at RT L's to end of deck)

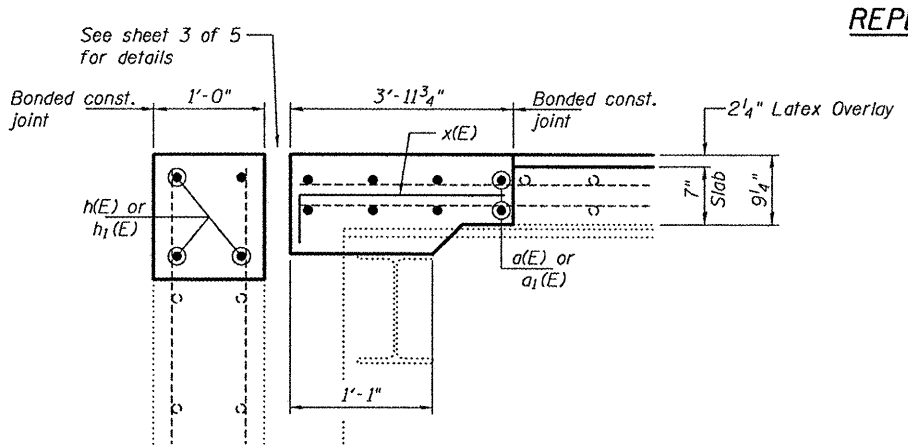

REPLACEMENT PLAN

SECTION B-B
(Near \bar{C} Roadway)
(Dims at RT L's to end of deck)

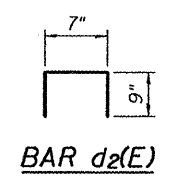

BAR d2(E)

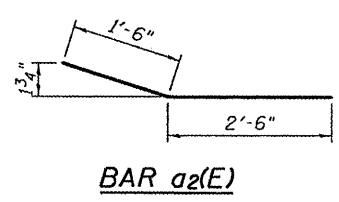

BAR a2(E)

BILL OF MATERIAL

Bar	No.	Size	Length	Shape
a(E)	18	#5	23'-3"	—
a1(E)	18	#5	28'-6"	—
a2(E)	8	#6	4'-0"	—
d(E)	12	#4	4'-10"	—
d1(E)	8	#5	3'-9"	—
d2(E)	4	#4	2'-1"	—
h(E)	4	#6	24'-6"	—
h1(E)	4	#6	30'-0"	—
x(E)	39	#5	5'-7"	—
Concrete Removal			Cu. Yd.	12.3
Concrete Superstructure			Cu. Yd.	12.2
Reinforcement Bars, Epoxy Coated			Lbs.	1,560

SOUTH ABUTMENT JOINT DETAILS
SN 090-0110

DESIGNED GGE
CHECKED I.J.L.
DRAWN Drew Christopher
CHECKED GGE I.J.L.

March 15, 2010
EXAMINED *Carl Krueger*
ENGINEER OF STRUCTURAL SERVICES
PASSED *Ralph E. Anderson*
ENGINEER OF BRIDGES AND STRUCTURES

Notes:
Hatched areas indicate removal.

SHEET NO. 2 5 SHEETS	F.A.P. RTE. 673	SECTION 101RS-3, 102RS-4, 103RS-4, 104RS-7	COUNTY Tazewell	TOTAL SHEETS 60	SHEET NO. 29
	CONTRACT NO. 68920			FED. ROAD DIST. NO. ILLINOIS FED. AID PROJECT	

* Granular or solid Flux filled headed studs conforming to Article 1006.32 of the Std. Specs., automatically end welded.

STATE OF ILLINOIS
DEPARTMENT OF TRANSPORTATION

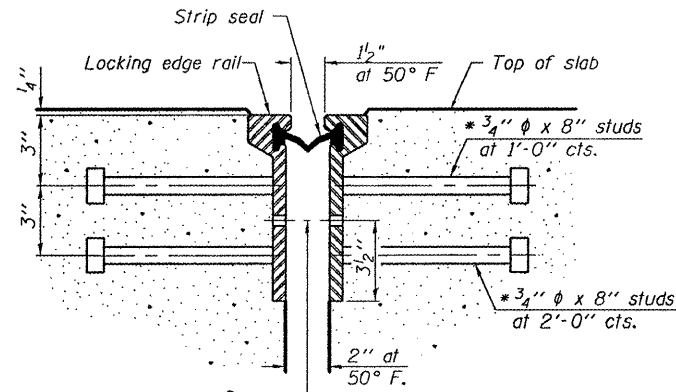

7/16" ϕ holes at 4'-0" cts. for 3/8" ϕ bolts. All bolts shall be burned, sawed, or chipped off flush with the plates after forms are removed, typ.

SECTION THRU
ROLLED RAIL JOINT

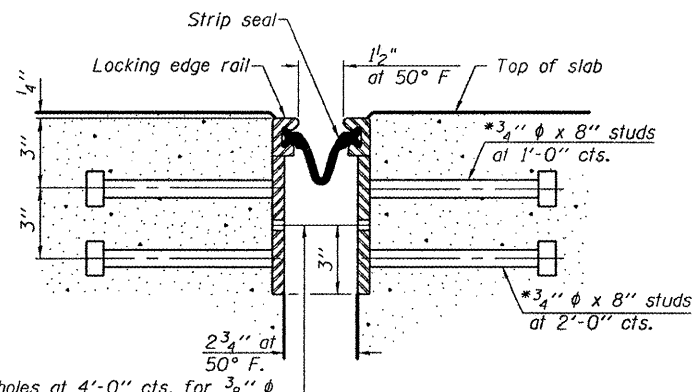

7/16" ϕ holes at 4'-0" cts. for 3/8" ϕ bolts. All bolts shall be burned, sawed, or chipped off flush with the plates after forms are removed, typ.

SECTION THRU
WELDED RAIL JOINT

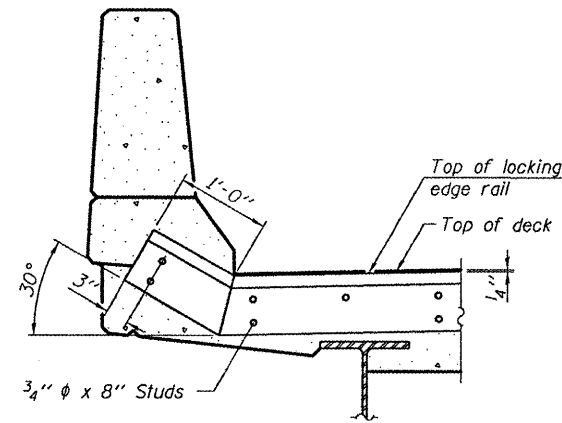

AT PARAPET

See Section A-A for end treatment of skew > 30°.

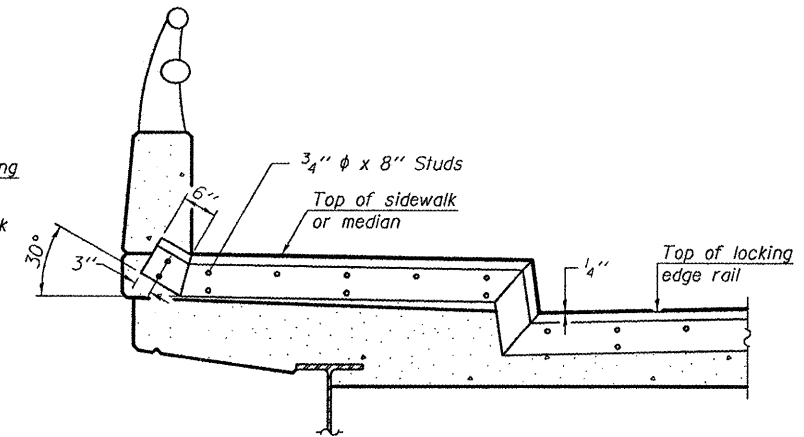

AT SIDEWALK OR MEDIAN

Shorter plates with a single row of studs at 12" cts. may be necessary on medians which are shallower than 9". See manufacturer's recommendation.

TYPICAL END TREATMENTS

Notes:

The strip seal shall be made continuous and shall have a minimum thickness of 1/4". The configuration of the strip seal shall match the configuration of the Locking Edge Rails. Open or "webbed" strip seal gland configurations are not permitted. The gland shall be sized for a maximum rated movement of 4 inches. The Locking Edge Rails depicted are conceptual only, except for the minimum dimensions shown. The actual configuration of the Locking Edge Rails and matching strip seal may vary from manufacturer to manufacturer. Flanged edge rails will not be allowed. Locking Edge Rails may be spliced at slope discontinuities.

The manufacturer's recommended installation methods shall be followed. The joint opening and deck dimensions detailed on the superstructure are based on a rolled rail expansion joint. If the Contractor elects to use the welded rail expansion joint, the opening and deck dimensions shall be modified according to the dimensions detailed on this sheet. Required modifications shall be made at no additional cost to the State.

All steel components shall be galvanized after fabrication according to Article 520.03 of the Standard Specifications. Maximum space between rail segments at stage lines shall be 3/16", sealed with a suitable sealant.

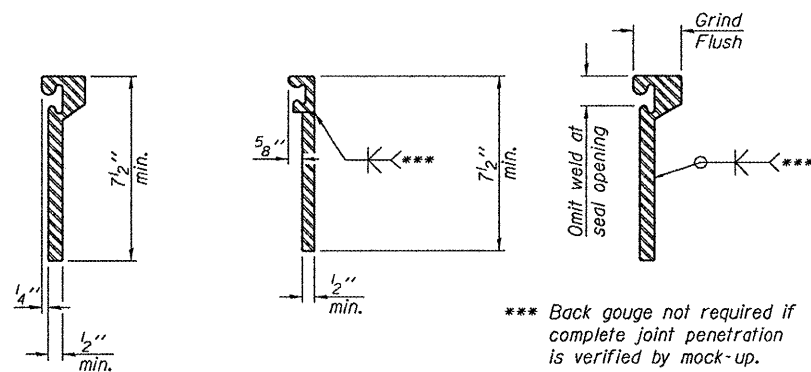

ROLLING
EXTRUDED RAIL

WELDED RAIL

LOCKING EDGE
RAIL SPLICE

The inside of the locking edge rail groove shall be free of weld residue. Rolled rail shown, welded rail similar.

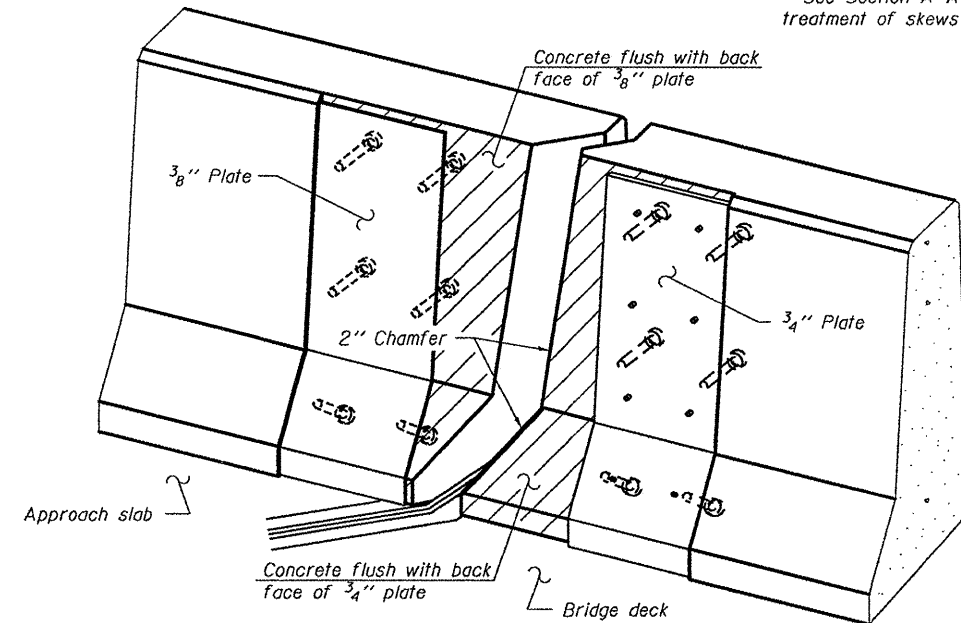

LOCKING EDGE RAILS

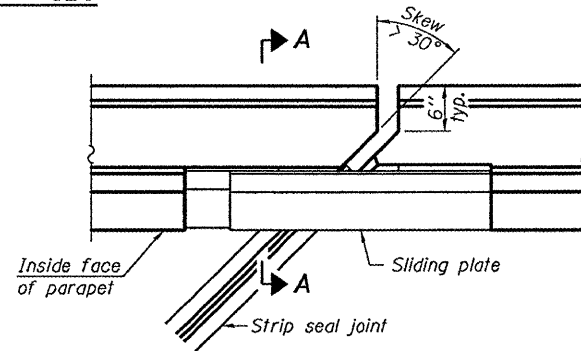

PLAN

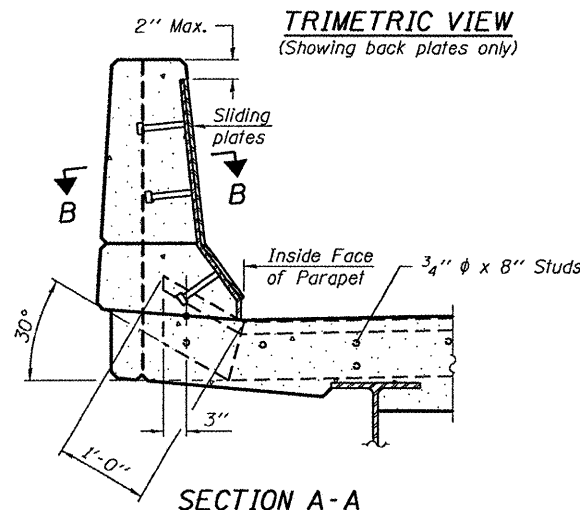

SECTION A-A

POINT BLOCK DETAILS
(for skew > 30°)

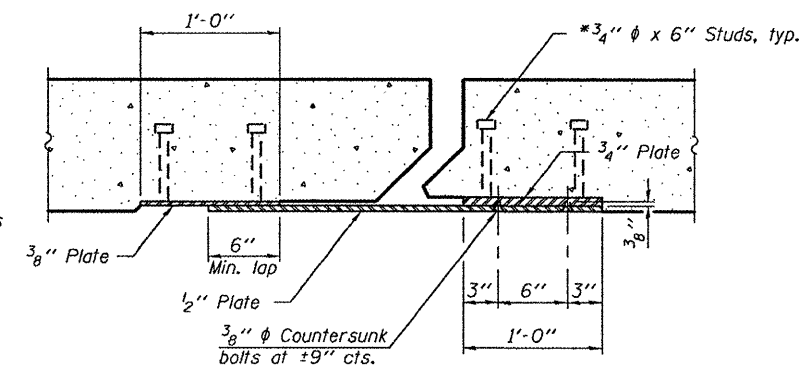

SECTION B-B

BILL OF MATERIAL

Item	Unit	Total
Preformed Joint Strip Seal	Foot	54.5

STRIP SEAL DETAILS
SN 090-0110

DESIGNED	GGE
CHECKED	I.J.L.
DRAWN	Drew Christopher
CHECKED	GGE I.J.L.

EXAMINED	March 15, 2010	<i>Carl Hoyer</i>
PASSED		<i>Ralph E. Anderson</i>

EJ-SSJ 11-1-09

SHEET NO. 3	F.A.P. RTE.	SECTION	COUNTY	TOTAL SHEETS	SHEET NO.
5 SHEETS	673	101RS-3, 102RS-4, 103RS-4, 104RS-7	Tazewell	60	30
FED. ROAD DIST. NO.			ILLINOIS	FED. AID PROJECT	
			CONTRACT NO. 68920		

STATE OF ILLINOIS
DEPARTMENT OF TRANSPORTATION

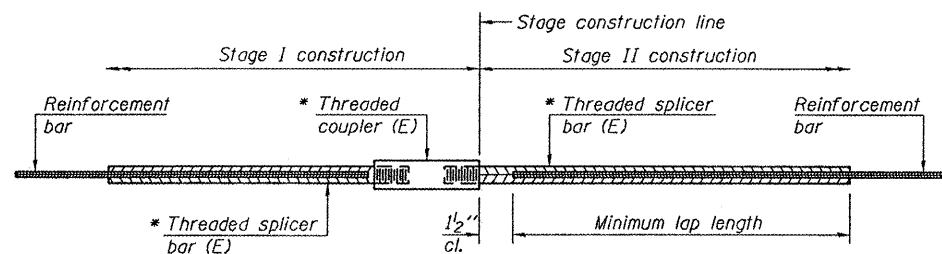

STANDARD BAR SPLICER ASSEMBLY

Bar size to be spliced	Minimum Lap Lengths			
	Table 1	Table 2	Table 3	Table 4
3, 4	1'-5"	1'-11"	2'-1"	2'-4"
5	1'-9"	2'-5"	2'-7"	2'-11"
6	2'-1"	2'-11"	3'-1"	3'-6"
7	2'-9"	3'-10"	4'-2"	4'-8"
8	3'-8"	5'-1"	5'-5"	6'-2"
9	4'-7"	6'-5"	6'-10"	7'-9"

Table 1: Black bar, 0.8 Class C
Table 2: Black bar, Top bar lap, 0.8 Class C
Table 3: Epoxy bar, 0.8 Class C
Table 4: Epoxy bar, Top bar lap, 0.8 Class C

Threaded splicer bar length = min. lap length + 1 1/2" + thread length

* Epoxy not required on Bar Splicer Assembly components used in conjunction with black bars.

Location	Bar size	No. assemblies required	Table for minimum lap length
S. Abutment	#5	18	3
S. Abutment	#6	4	3

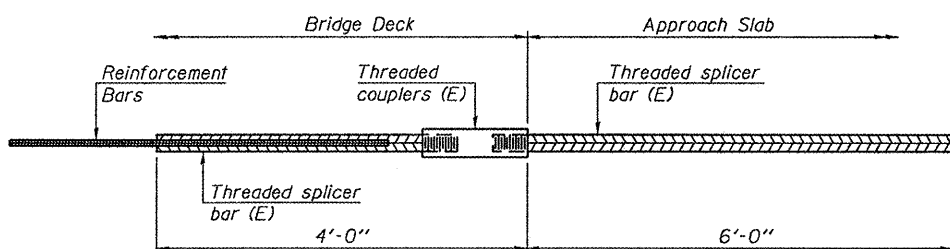

BAR SPLICER ASSEMBLY FOR #5 BAR ON INTEGRAL OR SEMI-INTEGRAL ABUTMENTS

No. required =

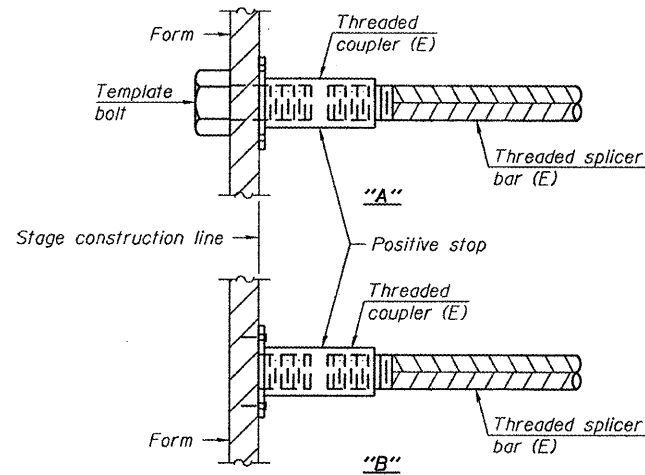

INSTALLATION AND SETTING METHODS

"A" : Set bar splicer assembly by means of a template bolt.
"B" : Set bar splicer assembly by nailing to wood forms or cementing to steel forms.
(E) : Indicates epoxy coating.

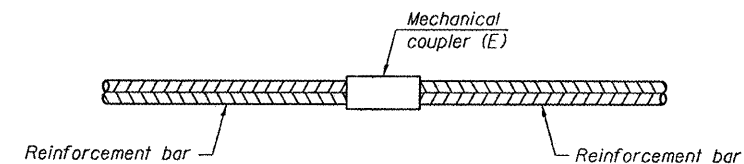

STANDARD MECHANICAL SPLICER

Location	Bar size	No. assemblies required

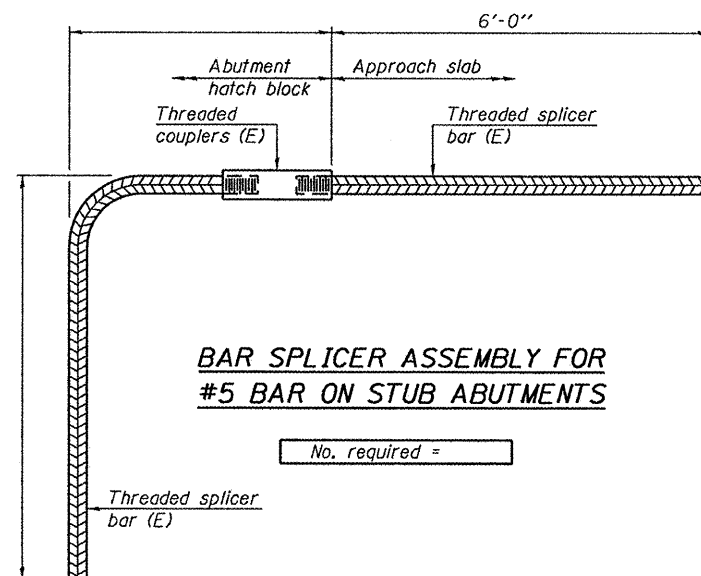

BAR SPLICER ASSEMBLY FOR #5 BAR ON STUB ABUTMENTS

No. required =

NOTES

Splicer bars shall be deformed with threaded ends and have a minimum 60 ksi yield strength.
All reinforcement shall be lapped and tied to the splicer bars.
Bar splicer assemblies shall be epoxy coated according to the requirements for reinforcement bars. See Section 508 of the Standard Specifications.
See special provision for Mechanical Splicers.
See approved list of bar splicer assemblies and mechanical splicers for alternatives.

DESIGNED	GGE
CHECKED	I.J.L.
DRAWN	Drew Christopher
CHECKED	GGE I.J.L.

March 15, 2010
EXAMINED <i>A. Carl</i>
PASSED <i>Ralph E. Anderson</i>

BSD-1 11-1-09

**BAR SPLICER DETAILS
SN 090-0110**

SHEET NO. 4 5 SHEETS	F.A.P. RTE. 673	SECTION 101RS-3, 102RS-4, 103RS-4, 104RS-7	COUNTY Tazewell	TOTAL SHEETS 60	SHEET NO. 31
	CONTRACT NO. 68920			FED. ROAD DIST. NO. ILLINOIS FED. AID PROJECT	

STATE OF ILLINOIS
DEPARTMENT OF TRANSPORTATION

Notes:

All Posts shall be normal to parapet.

In lieu of the cast-in-place anchor device shown, the Contractor has the option of drilling and setting stainless steel anchor rods of the same diameter and grade as the specified cap screws according to Article 509.06 of the Standard Specifications. Embedment shall be according to the manufacturer's specifications.

Removal and re-erection of the existing aluminum handrail, rail post, and all new applicable hardware, including labor and installation shall be included in the cost of Concrete Removal.

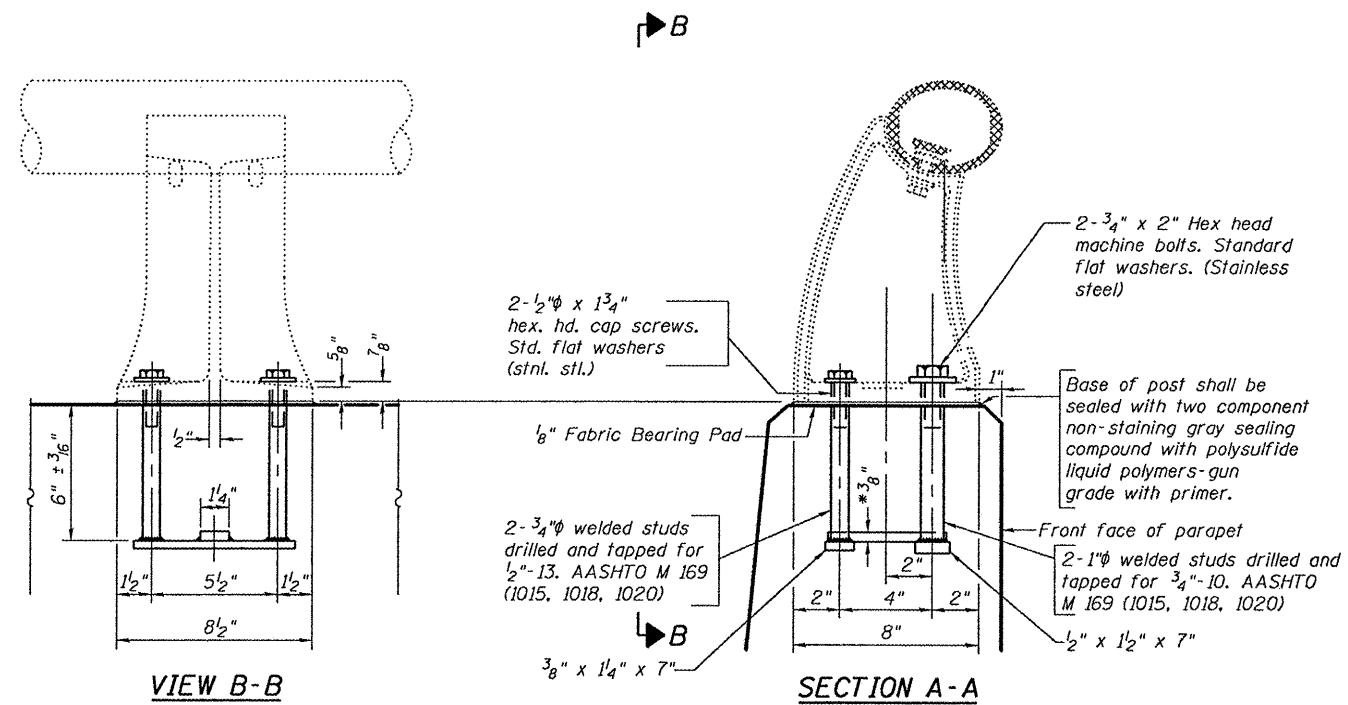

RAIL POST DETAILS

DESIGNED	GGE
CHECKED	I.J.L.
DRAWN	Drew Christopher
CHECKED	GGE I.J.L.

EXAMINED	March 15, 2010 <i>Carl Prosky</i> ENGINEER OF STRUCTURAL SERVICES
PASSED	<i>Ralph E. Anderson</i> ENGINEER OF BRIDGES AND STRUCTURES

RAILING DETAILS
SN 090-0110

SHEET NO.	F.A.P. RTE.	SECTION	COUNTY	TOTAL SHEETS	SHEET NO.
5	673	101RS-3, 102RS-4, 103RS-4, 104RS-7	Tazewell	60	31A
FED. ROAD DIST. NO. ILLINOIS				FED. AID PROJECT	
				CONTRACT NO. 68920	

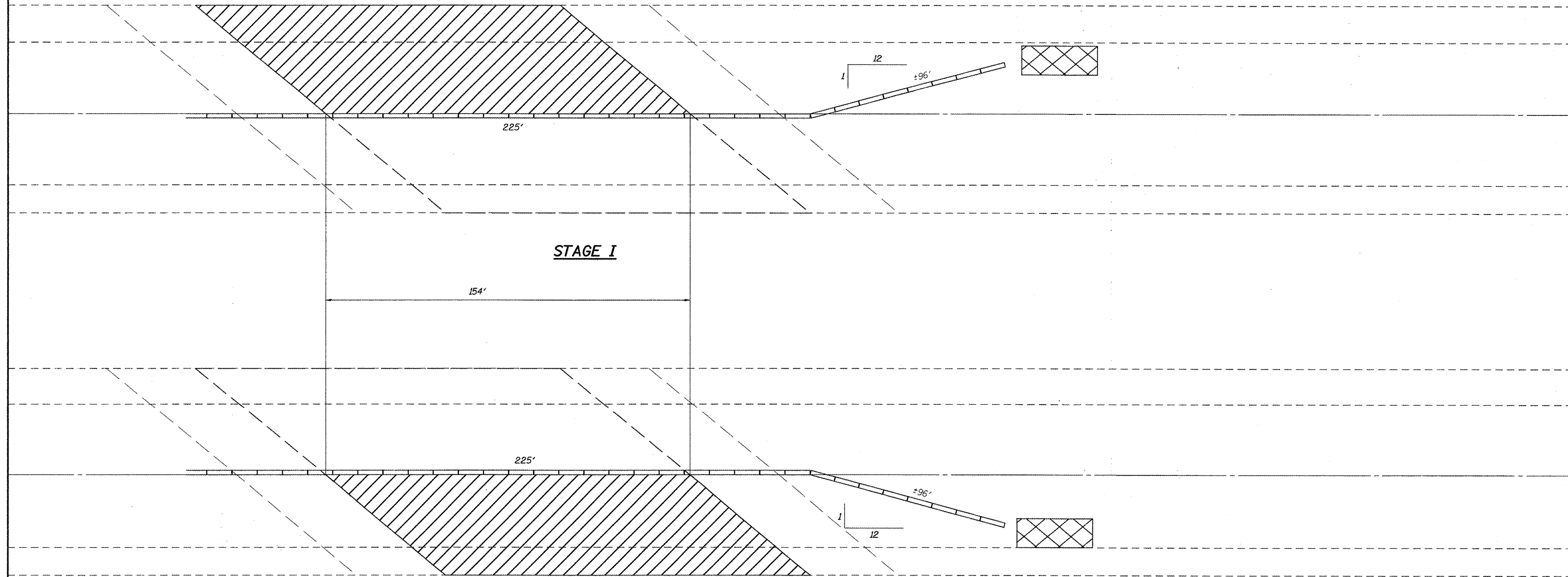
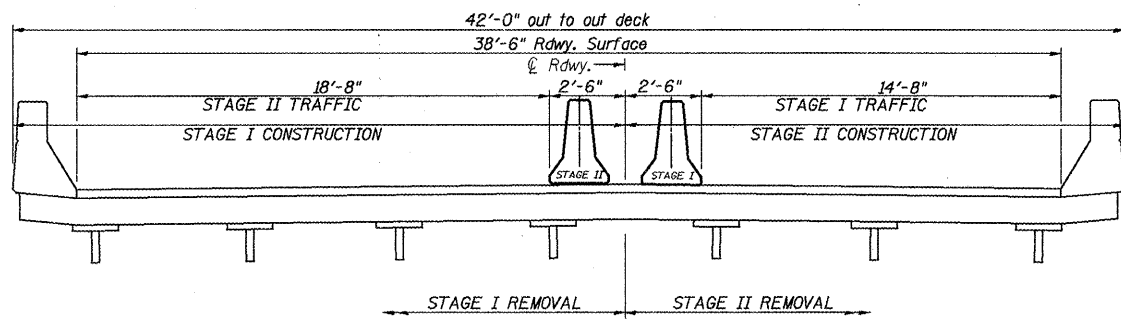

SYMBOLS

- Work Area
- Impact Attenuator
- Temporary Concrete Barrier
- Temporary Concrete Barrier

NOTES
 Refer to Highway Standards 701432 in conjunction with this sheet for exact placement of traffic management devices and other clarifications as construction staging symbols and dimensioning were duplicated off of this standard. Traffic staging sequence shall be at the discretion of the Engineer for given field applications. All barricades, drums and markers shall be as shown on the standard.

FILE NAME = 11116.dgn	USER NAME = hudsonne	DESIGNED -	REVISED -
		DRAWN -	REVISED -
	PLOT SCALE = 100.0000' / IN.	CHECKED -	REVISED -
	PLOT DATE = 1/29/2010	DATE -	REVISED -

**STATE OF ILLINOIS
 DEPARTMENT OF TRANSPORTATION**

S.N. 090-0110 STAGING (WB IL 116)

SCALE: SHEET NO. OF SHEETS STA. TO STA.

F.A.P. RTE. 673	SECTION ..	COUNTY TAZE/WOOD	TOTAL SHEETS 60	SHEET NO. 32
CONTRACT NO. 68920			ILLINOIS FED. AID PROJECT	

** 101RS-3; 102RS-4; 103RS-4; 104RS-7

TRAFFIC SIGNAL AND ITS FIBER SCHEDULE OF QUANTITIES											
ITEM DESCRIPTION	UNIT	TOTAL	ITS FIBER	IL 116 & HIGHVIEW	IL 116 & MARINERS/ ACCESS RD. 6	IL 116 & CENTENNIAL	IL 116 & ACCESS RD. 7	IL 116 & ACCESS RD. 8	IL 116 & WOODLAND KNOLLS	IL 116 & FANDEL	IL 116 & ARBOR VITAE/ SCHMITT
CONDUIT IN TRENCH, 2" DIA, PVC	FOOT	21523.0	21523.0								
CONDUIT PUSHED, 3" DIA, PVC	FOOT	950.0	950.0								
CONDUIT ATTACHED TO STRUCTURE, 2" DIA, GALVANIZED STEEL	FOOT	211.0	211.0								
JUNCTION BOX, STAINLESS STEEL, ATTACHED TO STRUCTURE, 24" X 24" X 10"	EACH	4.0	4.0								
DOUBLE HANDHOLE, PORTLAND CEMENT CONCRETE	EACH	13.0	13.0								
TRENCH AND BACKFILL FOR ELECTRICAL WORK	FOOT	21523.0	21523.0								
FULL-ACTUATED CONTROLLER AND TYPE IV CABINET, SPECIAL	EACH	1.0					1.0				
ELECTRIC CABLE IN CONDUIT, SIGNAL NO. 14 5C	FOOT	755.5					297.0		458.5		
DRILL EXISTING HANDHOLE	EACH	1.0	1.0								
INDUCTIVE LOOP DETECTOR	EACH	8.0					8.0				
DETECTOR LOOP, TYPE I	FOOT	6561.0		914.0	914.0	534.0	741.0	572.0	1186.0	850.0	850.0
PEDESTRIAN PUSH.BUTTON	EACH	8.0							2.0	4.0	2.0
REBUILD EXISTING SIGNAL HEAD, LED	EACH	8.0					2.0	2.0	4.0		
MODIFY EXISTING CONTROLLER CABINET	EACH	2.0						1.0	1.0		
LED SIGNAL FACE RETROFIT, RED BALL	EACH	22.0							6.0	8.0	8.0
LED SIGNAL FACE RETROFIT, GREEN BALL	EACH	21.0							5.0	8.0	8.0
LED SIGNAL FACE RETROFIT, GREEN ARROW	EACH	6.0							6.0		
BOND TRAFFIC SIGNAL STRUCTURE	EACH	28.0							10.0	9.0	9.0
ADJUST EXISTING DETECTOR LOOP RISER	EACH	40.0		6.0	6.0	4.0	5.0	5.0	6.0	4.0	4.0
FIBER OPTIC INTERCONNECT CENTER, 24 FIBER	EACH	3.0	3.0								
ELECTRIC CABLE IN CONDUIT, GROUNDING, NO. 6 1C	FOOT	1498.0							460.5	429.0	608.5
FIBER OPTIC CABLE IN CONDUIT, 62.5/125, MM12F SM24F	EACH	30536.0	30536.0								

TRAFFIC SIGNALS
SHEET 1 OF 15

* 101RS-3; 102RS-4; 103RS-4; 104RS-7 ** TAZEWELL & WOODFORD

FILE NAME = 1116.dgn	USER NAME = hudelsonne	DESIGNED -	REVISED -
		DRAWN -	REVISED -
		CHECKED -	REVISED -
		DATE -	REVISED -

**STATE OF ILLINOIS
DEPARTMENT OF TRANSPORTATION**

**PROPOSED TRAFFIC SIGNALS
SUMMARY OF QUANTITIES**

SCALE: Not to Scale SHEET NO. OF SHEETS STA. TO STA.

F.A.P. RTE. 673	SECTION	COUNTY	TOTAL SHEETS	SHEET NO.
			60	33
CONTRACT NO. 68920			ILLINOIS FED. AID PROJECT	

DETECTOR LOOP INSTALLATION - CONSTRUCTION NOTES	
1. DETECTOR LOOP REPLACEMENT QUANTITIES ARE ESTIMATED. THE CONTRACTOR SHALL ONLY REPLACE THE DETECTOR LOOPS THAT ARE DAMAGED BY THE MILLING PROCESS.	
2. A TYPE II SPLICE SHALL BE USED FOR ALL DETECTOR LEAD-INS.	
3. ALL DETECTOR LOOPS SHALL BE PLACED BACK INTO THEIR ORIGINAL LOCATIONS. ALL DETECTOR LOOPS SHALL BE INSTALLED IN THE CENTER OF THEIR RESPECTIVE TRAVEL LANES.	
4. THE PROPOSED DETECTOR LOOPS SHALL BE CUT IN THE MILLED SURFACE OR LEVELING BINDER COURSE BEFORE THE FINAL OVERLAY.	
5. THE CONTRACTOR SHALL NOTIFY THE ENGINEER OF TRAFFIC, RANDY LANINGA, AT (309) 671-4477 FORTY-EIGHT HOURS PRIOR TO BEGINNING MILLING OR PATCHING OPERATIONS.	
6. THESE ITEMS SHALL BE INCLUDED IN THE BID PRICE FOR DETECTOR LOOP, TYPE I PAY ITEM. THERE WILL BE NO ADDITIONAL COMPENSATION.	
CONTROLLER CABINET INSTALLATION - CONSTRUCTION NOTES	
1. THE CONTRACTOR SHALL REMOVE THE EXISTING TRAFFIC SIGNAL CABINET AND DELIVER THE CABINET AND ITS CONTENTS TO THE IDOT TRAFFIC BUILDING LOCATED AT 1025 W. DETWEILLER DR., PEORIA. THE CONTRACTOR SHALL NOTIFY PAUL GRANT, AT (309) 671-4474 FORTY-EIGHT HOURS IN ADVANCE OF EQUIPMENT DELIVERY.	
2. THE CONTRACTOR SHALL SCHEDULE THE REPLACEMENT OF THE TRAFFIC SIGNAL CABINET ONLY DURING THE HOURS OF 8:30 AM TO 3:00 PM MONDAY THROUGH FRIDAY.	
3. THE CONTRACTOR WILL BE ALLOWED TO PLACE THE INTERSECTION INTO ALL-RED FLASH MODE AND ALL-WAY STOP CONTROL ONLY DURING THE HOURS SPECIFIED ABOVE TO FACILITATE THE INSTALLATION OF THE PROPOSED TRAFFIC SIGNAL CONTROLLER CABINET.	
4. THE CONTRACTOR SHALL FURNISH AND INSTALL A MINIMUM OF TWO STOP SIGNS PER APPROACH WHEN THE INTERSECTION IS OPERATING IN ALL-RED FLASH MODE OR ALL-WAY STOP CONTROL.	
5. THE CONTRACTOR SHALL GROUND AND SAFETY-BOND THE PROPOSED CONTROLLER CABINET IN ACCORDANCE WITH NEC REQUIREMENTS.	
6. ALL COSTS (LABOR, MATERIALS, AND EQUIPMENT) ASSOCIATED WITH THESE REQUIREMENTS SHALL BE INCLUDED IN THE CONTRACT BID PRICE FOR THE TRAFFIC SIGNAL CABINET. THERE WILL BE NO ADDITIONAL COMPENSATION FOR THIS WORK.	
CONSTRUCTION NOTES	
1. ANY MAINTENANCE OF EXISTING TRAFFIC SIGNALS WILL BE CONSIDERED EXTRA WORK IN ACCORDANCE WITH ARTICLE 109.04 OF THE STANDARD SPECIFICATIONS.	
2. THE LOCATION OF ALL UTILITIES AND PRIVATELY OWNED FACILITIES SHALL BE FIELD VERIFIED BY THE CONTRACTOR PRIOR TO THE INSTALLATION OF ANY COMPONENTS.	
3. THE CONTRACTOR SHALL BE RESPONSIBLE FOR LOCATING EXISTING IDOT ELECTRICAL FACILITIES AT HIS/HER OWN EXPENSE IF REQUIRED. THE CONTRACTOR SHALL ALSO BE LIABLE FOR ANY DAMAGE TO IDOT FACILITIES RESULTING FROM INACCURATE LOCATING.	
4. ELECTRICAL WORK SHALL CONFORM WITH NATIONAL, STATE, AND LOCAL CODES.	
5. ALL LOOP RISERS AFFECTED BY THE MILLING OPERATIONS SHALL BE REFLECTED THROUGH THE NEW SURFACE AND ALL LOOP RISERS SHALL BE CHIPPED OUT AND FILLED WITH EPOXY. THIS WORK WILL BE PAID FOR UNDER THE PAY ITEM FOR "ADJUST EXISTING DETECTOR LOOP RISER".	
6. ALL TRAFFIC SIGNAL SECTIONS SHALL HAVE 12" SINGLE LED LENSES.	
7. THE RED SECTIONS OF THE SIGNAL HEADS SHARING THE SAME MAST ARM SHALL BE LEVEL WITH ONE ANOTHER AND MAINTAIN A 16 FT. MINIMUM CLEARANCE FROM THE HIGHEST POINT OF THE ROADWAY.	
8. ALL TRAFFIC SIGNAL HEAD BRACKETS ARE TO BE ALUMINUM WITH A NATURAL FINISH.	
9. THE EXISTING TRAFFIC SIGNALS SHALL REMAIN IN OPERATION DURING THE CONSTRUCTION OF THE PROPOSED TRAFFIC SIGNALS.	
10. REMOVAL OF EXISTING TRAFFIC SIGNAL ITEMS WILL NOT BE PAID FOR SEPARATELY, BUT SHALL BE INCLUDED IN THE UNIT BID PRICES FOR THE PROPOSED ITEMS.	
11. THE CONTRACTOR SHALL PROVIDE ELECTRICAL CABLE SLACK IN ACCORDANCE WITH ARTICLE 873.03 UNLESS SPECIFIED OTHERWISE.	
12. ELECTRICAL CABLE WILL BE MEASURED FOR PAYMENT IN ACCORDANCE WITH ARTICLE 873.04.	
13. ALL SURPLUS MATERIALS SHALL BE DISPOSED OF IN ACCORDANCE WITH ARTICLE 202.03 OF THE STANDARD SPECIFICATION.	
14. THE LOCATIONS FOR HANDHOLES ARE PROVIDED FOR REFERENCE ONLY. THE ENGINEER OF TRAFFIC SHALL BE NOTIFIED FOR LOCATION VERIFICATION BEFORE INSTALLATION.	
15. PROPOSED HANDHOLES SHALL BE CAST IN PLACE CONCRETE HANDHOLES.	
16. THE HANDHOLE SHALL BE CONSTRUCTED SO THAT THE TOP OF THE FRAME WILL BE FLUSH WITH THE SURFACE OF THE MEDIAN, SIDEWALK, OR GROUND LINE.	
17. COILABLE POLYETHYLENE DUCT MAY BE SUBSTITUTED FOR PVC PUSHED OR TRENCHED.	
18. THE CONTRACTOR MAY ELECT TO PUSH A CONDUIT THAT IS SHOWN TO BE TRENCHED ON THE PLANS. HOWEVER, THIS WORK WILL BE MEASURED FOR PAYMENT AND PAID FOR AS CONDUIT IN TRENCH OF THE TYPE AND SIZE SPECIFIED AND TRENCH AND BACKFILL FOR ELECTRICAL WORK.	
19. POTHOLES TO LOCATE EXISTING UNDERGROUND UTILITIES SHALL BE INCLUDED IN THE CONTRACT BID PRICE FOR THE CONDUIT PAY ITEMS (PUSHED OR TRENCHED).	
20. REMOVAL AND REPLACEMENT OF EXISTING SIDEWALK, PAVEMENT, AND ISLANDS FOR UTILITY LOCATING PURPOSES WILL NOT BE PAID FOR SEPARATELY, BUT SHALL BE INCLUDED IN THE CONTRACT BID PRICE FOR THE CONDUIT PAY ITEMS.	
21. NO ADDITIONAL COMPENSATION SHALL BE ALLOWED FOR PLACING CONDUIT AT GREATER THAN 2 FT. MINIMUM DEPTH TO AVOID OBSTACLES SUCH AS UNDERGROUND UTILITIES.	
22. THE CONTRACTOR IS RESPONSIBLE FOR THE COST OF UNCOVERING OR HAND DIGGING AROUND UTILITIES AS NECESSARY. THIS COST OF THIS WORK SHALL BE INCLUDED IN THE UNIT PRICES FOR THE CONDUITS.	
23. THE CONTRACTOR SHALL INSTALL A #10 (EPR-TYPE RHW) TRACER WIRE ALONG WITH THE FIBER OPTIC CABLE. THE TRACER WIRE SHALL BE CONTINUOUS AND BE ACCESSIBLE FROM THE TRAFFIC SIGNAL CONTROLLER CABINETS AND HANDHOLES. THE COST OF FURNISHING AND INSTALLING THE TRACER WIRE SHALL BE INCLUDED IN THE UNIT BID PRICE FOR THE FIBER OPTIC CABLE IN CONDUIT PAY ITEM.	
24. THE EXISTING TRAFFIC SIGNALS SHALL REMAIN IN OPERATION DURING THE CONSTRUCTION OF THE PROPOSED TRAFFIC SIGNALS.	
25. ALL TRAFFIC SIGNAL STRUCTURES SHALL BE BONDED IN ACCORDANCE WITH NEC REQUIREMENTS. THIS WORK SHALL BE PAID FOR AT THE CONTRACT UNIT PRICE FOR "BOND TRAFFIC SIGNAL STRUCTURE" AND SHALL INCLUDE ALL LABOR, EQUIPMENT, AND MATERIALS (INCLUDING CLAMPS, HARDWARE, ELECTRICAL CABLE, AND ALL OTHER ITEMS REQUIRED TO BOND THE STRUCTURES).	
26. A FIVE FOOT PIECE OF GREEN INSULATED #8 1/C XLP-USE CABLE SHALL BE USED TO CONNECT THE HANDHOLE LID TO THE FRAME. THE COST OF THIS WIRE SHALL BE INCLUDED IN THE CONTRACT BID PRICE FOR "BOND TRAFFIC SIGNAL STRUCTURE".	
27. THE CONTRACTOR SHALL BE RESPONSIBLE FOR LOCATING ALL EXISTING UNDERDRAIN CLEANOUTS AND REPAIRING ANY DAMAGE DONE TO ROADWAY UNDERDRAINS THAT OCCURS DURING CONDUIT INSTALLATION.	
28. THE CONTRACTOR SHALL FURNISH AND INSTALL 2" GALVANIZED CONDUIT FOR ALL CONDUIT INSTALLED ABOVE GROUND (WITH ONE FOOT INSTALLED BELOW GRADE) AND UTILIZED FOR THE INSTALLATION OF THE STAINLESS STEEL JUNCTION BOXES ATTACHED TO STRUCTURE. THE COST OF THIS CONDUIT SHALL BE INCLUDED IN THE UNIT BID PRICE FOR THE JUNCTION BOX PAY ITEM.	

TRAFFIC SIGNALS
SHEET 2 OF 15

* 101RS-3; 102RS-4; 103RS-4; 104RS-7 ** TAZEWELL & WOODFORD

FILE NAME = 1116.dgn	USER NAME = hudelsonne	DESIGNED -	REVISED -	STATE OF ILLINOIS DEPARTMENT OF TRANSPORTATION	TRAFFIC SIGNAL DETECTOR LOOP REPLACEMENT LOCATIONS	F.A.P. RTE.	SECTION	COUNTY	TOTAL SHEETS	SHEET NO.	
	PLOT SCALE = 100.0000' / IN.	DRAWN -	REVISED -			673	.	**	60	34	
	PLOT DATE = 1/29/2018	CHECKED -	REVISED -			SCALE: Not to Scale		SHEET NO. OF SHEETS STA. TO STA.		CONTRACT NO. 68920	
		DATE -	REVISED -			ILLINOIS FED. AID PROJECT					

DETECTOR LOOP AND DETECTOR ASSIGNMENT SCHEDULE - IL 116 & HIGHVIEW/ACCESS RD. #4						
DETECTOR LOOP	TYPE	DETECTOR LOOP QTY.	DETECTOR LEAD-IN QTY.	ASSIGNED PHASE	ADJUST LOOP RISER	COMMENTS
D-1	6' X 50' QUAD	162	6	1	1	IL 116 SOUTHBOUND LEFT TURN LANE (ONTO HIGHVIEW RD.)
D-2A	6' X 6'	24	15	2	1	IL 116 NORTHBOUND (LEFT LANE)
D-2B	6' X 6'	24	8	2		IL 116 NORTHBOUND (RIGHT LANE)
D-4A	6' X 50' QUAD	162	8	4	1	ACCESS RD. #4 EASTBOUND (THRU/LEFT TURN LANE)
D-4B	6' X 14'	40	8	4		ACCESS RD. #4 EASTBOUND (RIGHT TURN LANE)
D-5	6' X 50' QUAD	162	6	5	1	IL 116 NORTHBOUND LEFT TURN LANE (ONTO ACCESS RD. #4)
D-6A	6' X 6'	24	15	6	1	IL 116 SOUTHBOUND (LEFT LANE)
D-6B	6' X 6'	24	8	6		IL 116 SOUTHBOUND (RIGHT LANE)
D-8A	6' X 50' QUAD	162	8	8	1	HIGHVIEW RD. WESTBOUND (THRU/LEFT LANE)
D-8B	6' X 14'	40	8	8		HIGHVIEW RD. WESTBOUND (RIGHT TURN LANE)
TOTAL:		824	90		6	

DETECTOR LOOP AND DETECTOR ASSIGNMENT SCHEDULE - IL 116 & MARINERS WAY/ACCESS RD. #6						
DETECTOR LOOP	TYPE	DETECTOR LOOP QTY.	DETECTOR LEAD-IN QTY.	ASSIGNED PHASE	ADJUST LOOP RISER	COMMENTS
D-1	6' X 50' QUAD	162	6	1	1	IL 116 SOUTHBOUND LEFT TURN LANE (ONTO ACCESS RD. #6)
D-2A	6' X 6'	24	15	2	1	IL 116 NORTHBOUND (LEFT LANE)
D-2B	6' X 6'	24	8	2		IL 116 NORTHBOUND (RIGHT LANE)
D-4A	6' X 50' QUAD	162	8	4	1	MARINERS WAY EASTBOUND (THRU/LEFT TURN LANE)
D-4B	6' X 14'	40	8	4		MARINERS WAY EASTBOUND (RIGHT TURN LANE)
D-5	6' X 50' QUAD	162	6	5	1	IL 116 NORTHBOUND LEFT TURN LANE (ONTO MARINERS WAY)
D-6A	6' X 6'	24	15	6	1	IL 116 SOUTHBOUND (LEFT LANE)
D-6B	6' X 6'	24	8	6		IL 116 SOUTHBOUND (RIGHT LANE)
D-8A	6' X 50' QUAD	162	8	8	1	ACCESS RD. #6 WESTBOUND (THRU/LEFT TURN LANE)
D-8B	6' X 14'	40	8	8		ACCESS RD. #6 WESTBOUND (RIGHT TURN LANE)
TOTAL:		824	90		6	

DETECTOR LOOP AND DETECTOR ASSIGNMENT SCHEDULE - IL 116 & CENTENNIAL DR.						
DETECTOR LOOP	TYPE	DETECTOR LOOP QTY.	DETECTOR LEAD-IN QTY.	ASSIGNED PHASE	ADJUST LOOP RISER	COMMENTS
D-1	6' X 50' QUAD	162	12	1	1	IL 116 SOUTHBOUND LEFT TURN LANE (ONTO CENTENNIAL)
D-2A	6' X 6'	24	15	2	1	IL 116 NORTHBOUND (LEFT LANE)
D-2B	6' X 6'	24	8	2		IL 116 NORTHBOUND (RIGHT LANE)
D-6A	6' X 6'	24	15	6	1	IL 116 SOUTHBOUND (LEFT LANE)
D-6B	6' X 6'	24	8	6		IL 116 SOUTHBOUND (RIGHT LANE)
D-8A	6' X 50' QUAD	162	8	8	1	CENTENNIAL DR. WESTBOUND (THRU/LEFT TURN LANE)
D-8B	6' X 14'	40	8	8		CENTENNIAL DR. WESTBOUND (RIGHT TURN LANE)
TOTAL:		460	74		4	

SCHEDULE OF DETECTOR LOOP QUANTITIES		
IL 116 & HIGHVIEW/ACCESS RD. 4, IL 116 & MARINERS WAY/ACCESS RD. 6, IL 116 & CENTENNIAL		
DETECTOR LOOP, TYPE I	FOOT	2362.0
ADJUST EXISTING DETECTOR LOOP RISER	EACH	16.0

TRAFFIC SIGNALS
SHEET 3 OF 15

• 101RS-3; 102RS-4; 103RS-4; 104RS-7 ** TAZEWELL & WOODFORD

FILE NAME = 11116.dgn	USER NAME = hudeleonme	DESIGNED -	REVISED -	STATE OF ILLINOIS DEPARTMENT OF TRANSPORTATION	TRAFFIC SIGNAL DETECTOR LOOP REPLACEMENT LOCATIONS IL 116 (HIGHVIEW/ACCESS RD. 4, MARINERS/ACCESS RD. 6, CENTENNIAL)	F.A.P. RTE. 673	SECTION .	COUNTY ..	TOTAL SHEETS 10	SHEET NO. 35	
	PLOT SCALE = 1/80.0000' / IN.	DRAWN -	REVISED -			SCALE: Not to Scale SHEET NO. OF SHEETS STA. TO STA.		CONTRACT NO. 68920		ILLINOIS FED. AID PROJECT	
	PLOT DATE = 1/29/2010	CHECKED -	REVISED -								
		DATE -	REVISED -								

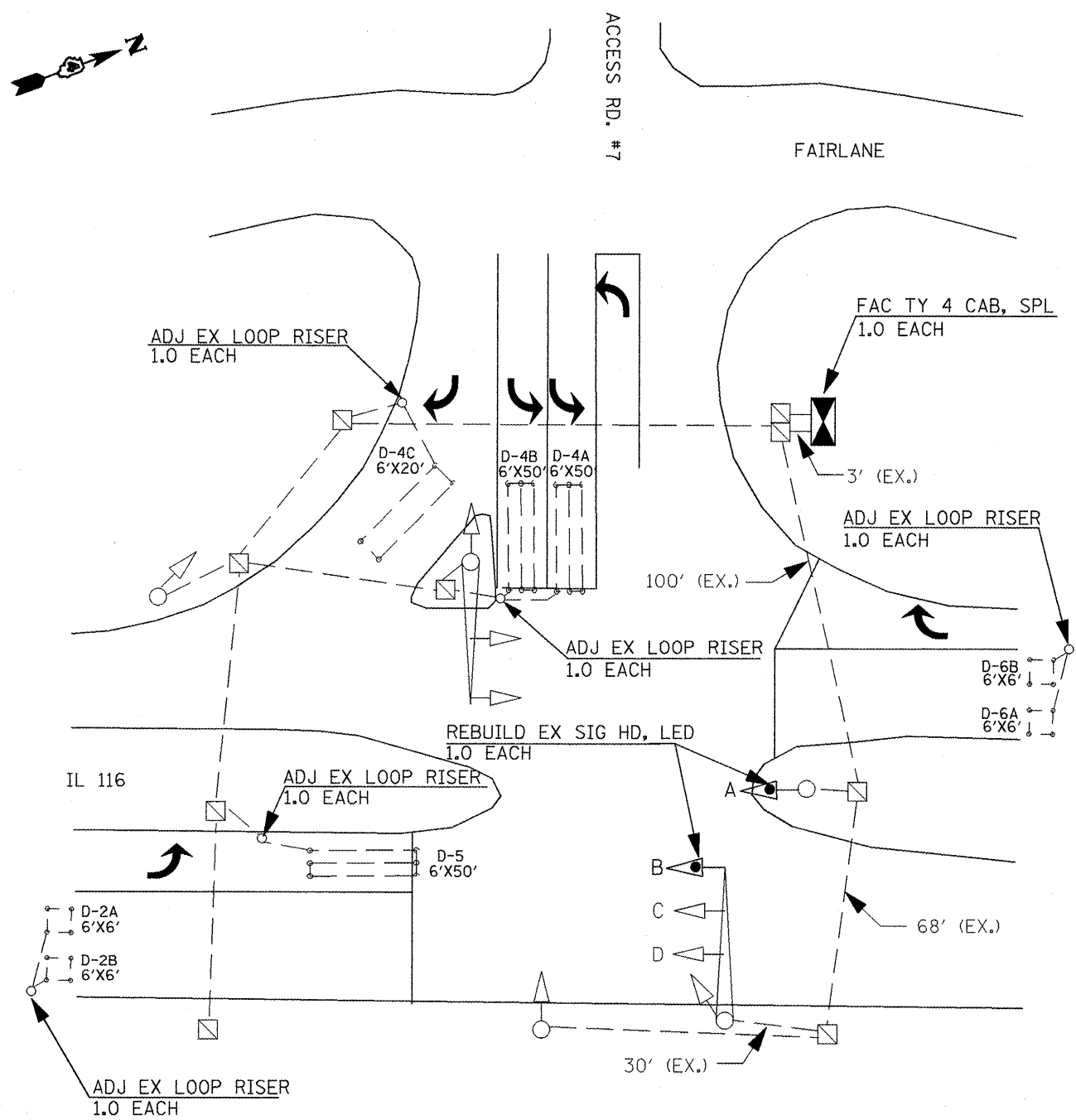

TRAFFIC SIGNAL LEGEND

	EX. DETECTOR LOOP (6'X6')
	EX. DETECTOR LOOP (6'X50' QUAD)
	EX. HANDHOLE
	EX. CONDUIT
	EX. ELECTRICAL SERVICE
	EX. TRAFFIC SIGNAL HEAD
	PROP. SIGNAL HEAD (REBUILT)
	PROP. TRAFFIC SIGNAL CONTROLLER

HEAD "A" (BM)		HEAD "B" (MAM)	
EX.	PROP.	EX.	PROP.
(7)	(7)	(7)	(7)
R	R	R	R
Y	Y	Y	Y
G	Y	G	Y
Y/G	G	Y/G	G

INSTALL NEW 5/C CABLE FOR MAM HEADS "C" AND "D" (JUMPER HEADS)

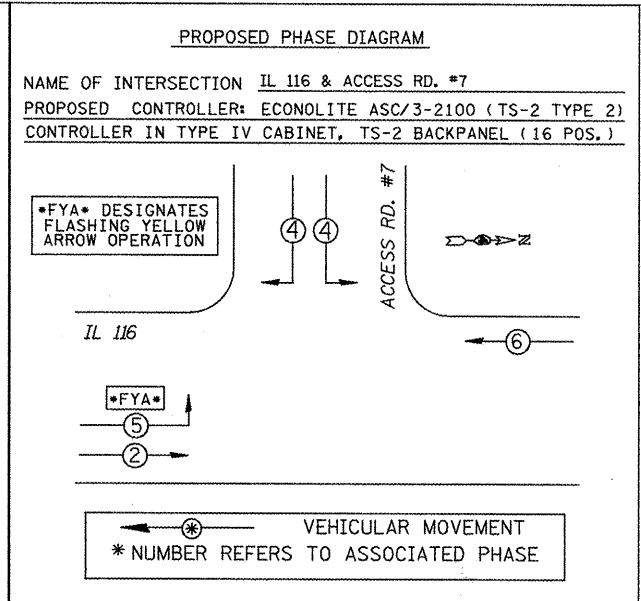
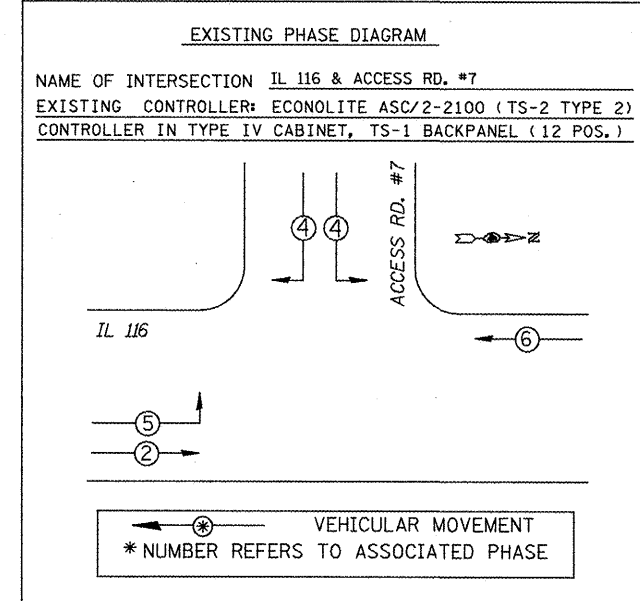

DETECTOR LOOP AND DETECTOR ASSIGNMENT SCHEDULE - IL 116 & ACCESS RD. #7

DETECTOR LOOP	TYPE	DETECTOR LOOP QTY.	DETECTOR LEAD-IN QTY.	ASSIGNED PHASE	ADJUST LOOP RISER	CHANNELS REQUIRED	COMMENTS
D-2A	6' X 6'	24	15	2	1	1	IL 116 NORTHBOUND (LEFT LANE)
D-2B	6' X 6'	24	8	2		1	IL 116 NORTHBOUND (RIGHT LANE)
D-4A	6' X 50' QUAD	162	20	4	1	1	ACCESS RD. #7 EASTBOUND (INSIDE LEFT TURN LANE)
D-4B	6' X 50' QUAD	162	8	4		1	ACCESS RD. #7 EASTBOUND (OUTSIDE LEFT TURN LANE)
D-4C	6' X 20'	52	25	4		1	ACCESS RD. #7 EASTBOUND (RIGHT TURN LANE)
D-5	6' X 50' QUAD	162	8	5	1	1	IL 116 NORTHBOUND LEFT (ONTO ACCESS RD. #7)
D-6A	6' X 6'	24	15	6	1	1	IL 116 SOUTHBOUND (LEFT LANE)
D-6B	6' X 6'	24	8	6		1	IL 116 SOUTHBOUND (RIGHT LANE)
TOTAL:		634	107		5	8	

SCHEDULE OF QUANTITIES
IL 116 & ACCESS RD. #7

DESCRIPTION	UNIT	QUANTITY
FULL-ACTUATED CONTROLLER AND TYPE IV CABINET, SPL	EACH	1.0
ELECTRIC CABLE IN CONDUIT, SIGNAL NO. 14 5C	FOOT	297.0
INDUCTIVE LOOP DETECTOR	EACH	8.0
DETECTOR LOOP, TYPE I	FOOT	741.0
REBUILD EXISTING SIGNAL HEAD, LED	EACH	2.0
ADJUST EXISTING DETECTOR LOOP RISER	EACH	5.0

TRAFFIC SIGNALS
SHEET 4 OF 15

FILE NAME = 1116.dgn	USER NAME = hudeisonne	DESIGNED -	REVISED -
		DRAWN -	REVISED -
		CHECKED -	REVISED -
		DATE -	REVISED -

STATE OF ILLINOIS
DEPARTMENT OF TRANSPORTATION

PROPOSED TRAFFIC SIGNALS
IL 116 & ACCESS RD. #7

SCALE: Not to Scale SHEET NO. OF SHEETS STA. TO STA.

F.A.P. RTE. 673	SECTION	COUNTY	TOTAL SHEETS 60	SHEET NO. 30
			CONTRACT NO. 68920	

ILLINOIS FED. AID PROJECT

101RS-3; 102RS-4; 103RS-4; 104RS-7 ** TAZEWELL & WOODFORD

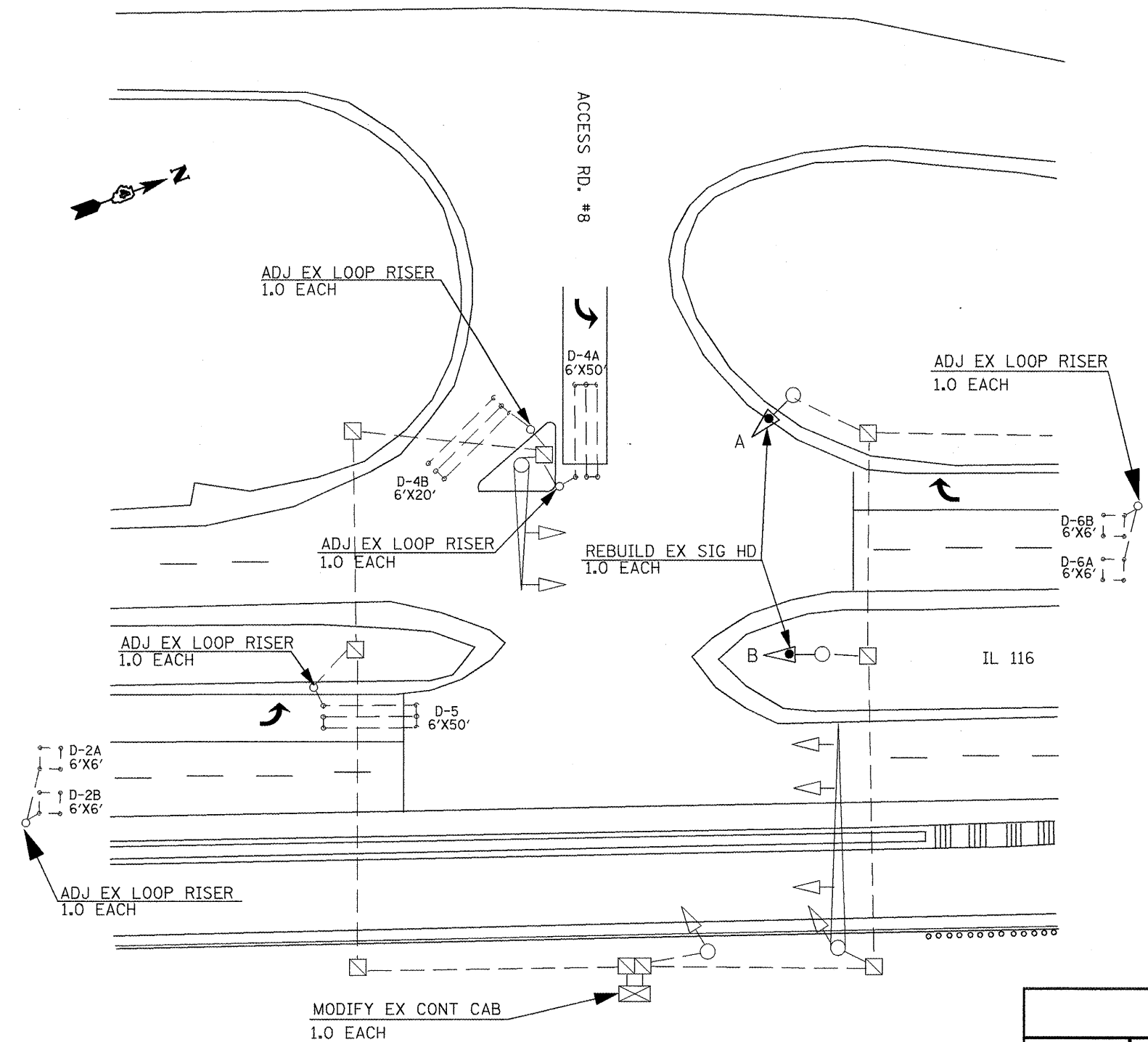

TRAFFIC SIGNAL LEGEND

	EX. DETECTOR LOOP (6'X6')
	EX. DETECTOR LOOP (6'X50' QUAD)
	EX. CONTROLLER CABINET
	EX. HANDHOLE
	EX. CONDUIT
	EX. ELECTRICAL SERVICE
	EX. TRAFFIC SIGNAL HEAD
	PROP. SIGNAL HEAD (REBUILT)

HEAD "A" (BM)		HEAD "B" (BM)	
EX.	PROP.	EX.	PROP.
7	7	7	7
R	R	R	R
Y	Y	Y	Y
G	Y	G	Y
Y	G	Y	G
G	G	G	G

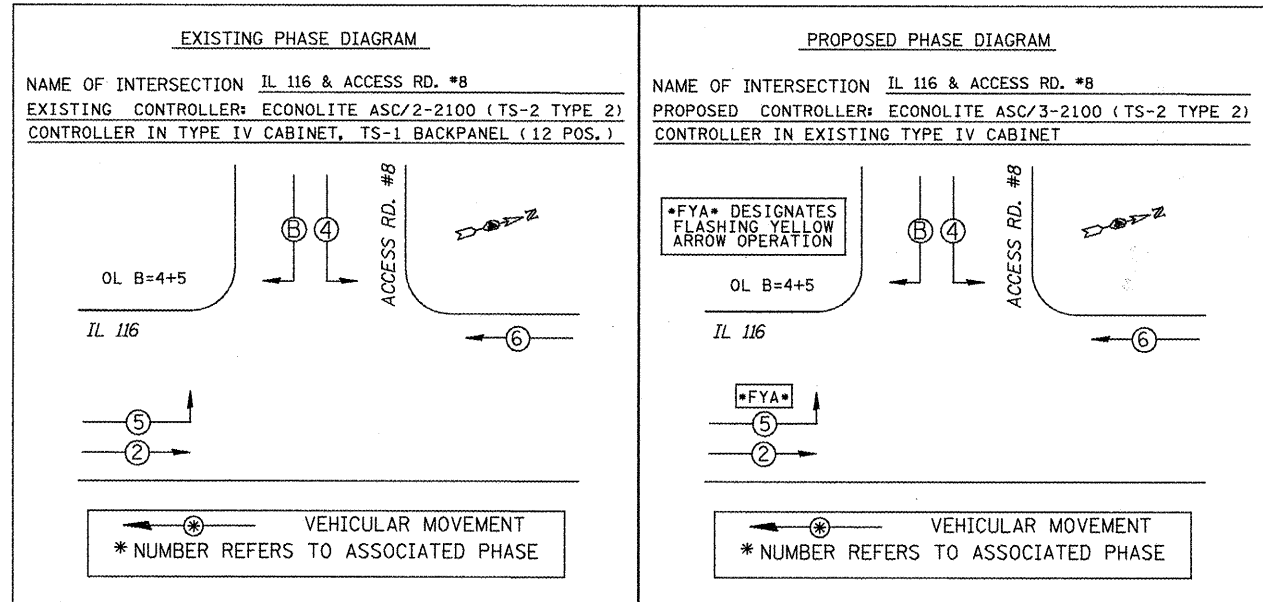

SCHEDULE OF QUANTITIES
IL 116 & ACCESS RD. #8

DESCRIPTION	UNIT	QUANTITY
DETECTOR LOOP, TYPE I	FOOT	572.0
REBUILD EXISTING SIGNAL HEAD, LED	EACH	2.0
MODIFY EXISTING CONTROLLER CABINET	EACH	1.0
ADJUST EXISTING DETECTOR LOOP RISER	EACH	5.0

DETECTOR LOOP AND DETECTOR ASSIGNMENT SCHEDULE - IL 116 & ACCESS RD. #8

DETECTOR LOOP	TYPE	DETECTOR LOOP QTY.	DETECTOR LEAD-IN QTY.	ASSIGNED PHASE	ADJUST LOOP RISER	COMMENTS
D-2A	6' X 6'	24	15	2	1	IL 116 NORTHBOUND (LEFT LANE)
D-2B	6' X 6'	24	8	2		IL 116 NORTHBOUND (RIGHT LANE)
D-4A	6' X 50' QUAD	162	20	4	1	ACCESS RD. #8 EASTBOUND (LEFT TURN LANE)
D-4B	6' X 20' QUAD	72	8	4	1	ACCESS RD. #8 EASTBOUND (LEFT TURN LANE)
D-5	6' X 50' QUAD	162	6	5	1	IL 116 NORTHBOUND LEFT (ONTO ACCESS RD. #8)
D-6A	6' X 6'	24	15	6	1	IL 116 SOUTHBOUND (LEFT LANE)
D-6B	6' X 6'	24	8	6		IL 116 SOUTHBOUND (RIGHT LANE)
TOTAL:		492	80		5	

FILE NAME = 11116.dgn	USER NAME = hudsonme	DESIGNED -	REVISED -
		DRAWN -	REVISED -
		CHECKED -	REVISED -
		DATE -	REVISED -

STATE OF ILLINOIS
DEPARTMENT OF TRANSPORTATION

PROPOSED TRAFFIC SIGNALS
IL 116 & ACCESS RD. #8

SCALE: Not to Scale SHEET NO. OF SHEETS STA. TO STA.

F.A.P. RTE. 673	SECTION	COUNTY	TOTAL SHEETS	SHEET NO.
			60	37
CONTRACT NO. 68920				

• 101RS-3; 102RS-4; 103RS-4; 104RS-7 • TAZEVELL & WOODFORD

TRAFFIC SIGNALS
SHEET 5 OF 15

ILLINOIS FED. AID PROJECT

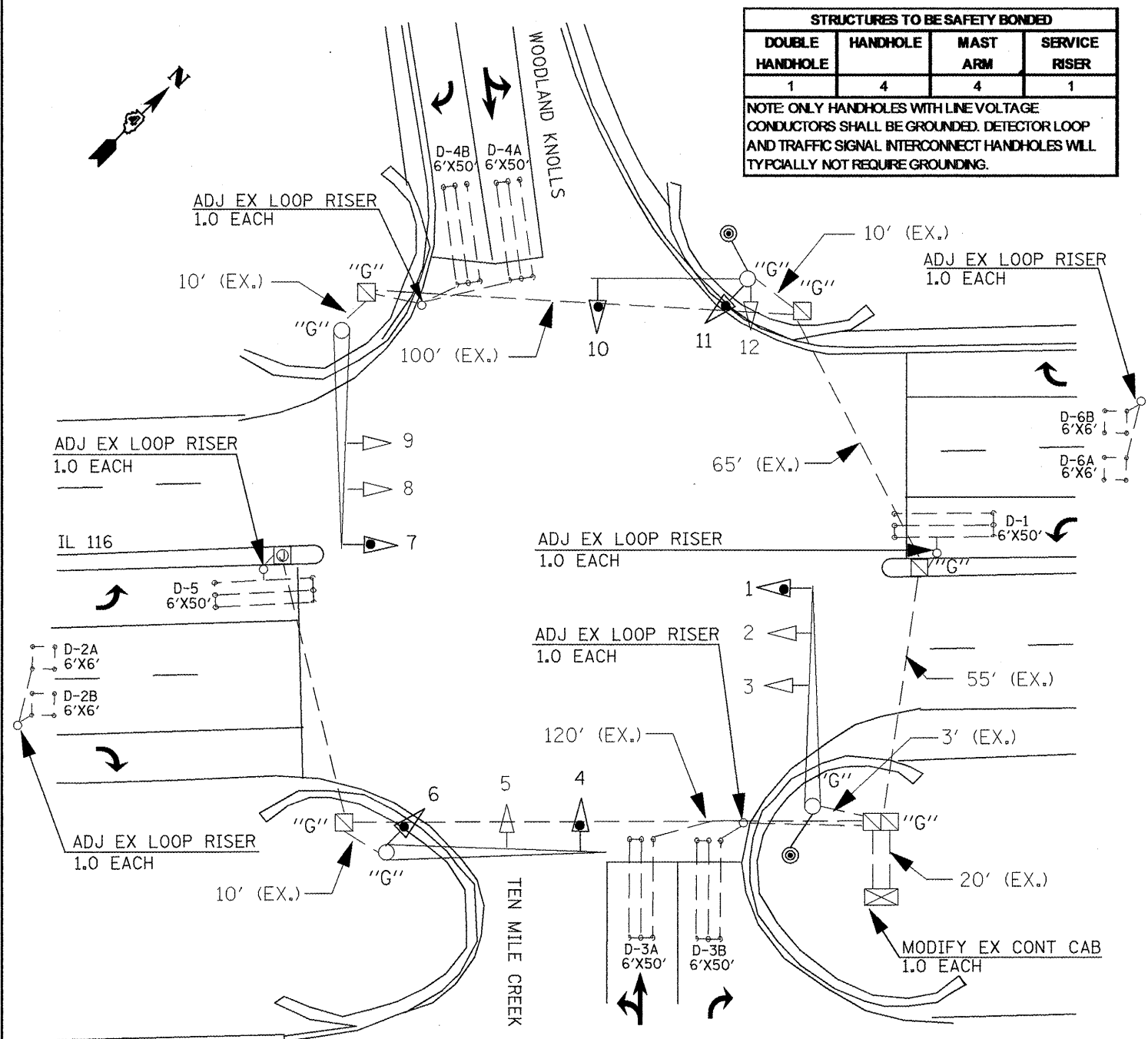

STRUCTURES TO BE SAFETY BONDED			
DOUBLE HANDHOLE	HANDHOLE	MAST ARM	SERVICE RISER
1	4	4	1

NOTE: ONLY HANDHOLES WITH LINE VOLTAGE CONDUCTORS SHALL BE GROUNDED. DETECTOR LOOP AND TRAFFIC SIGNAL INTERCONNECT HANDHOLES WILL TYPICALLY NOT REQUIRE GROUNDING.

TRAFFIC SIGNAL LEGEND

- EX. DETECTOR LOOP (6'X6')
- EX. DETECTOR LOOP (6'X50' QUAD)
- EX. CONTROLLER CABINET
- EX. HANDHOLE
- EX. CONDUIT
- EX. ELECTRICAL SERVICE
- EX. TRAFFIC SIGNAL HEAD
- PROP. SIGNAL HEAD (REBUILT)
- EX. STRUCTURE TO BE SAFETY BONDED
- PROP. PEDESTRIAN PUSHBUTTON

SCHEDULE OF QUANTITIES
IL 116 & WOODLAND KNOLLS/TEN MILE CREEK RD.

ITEM	UNIT	QUANTITY
DETECTOR LOOP, TYPE I	FOOT	1186.0
ELECTRIC CABLE IN CONDUIT, SIGNAL NO. 14 5C	FOOT	458.5
REBUILD EXISTING SIGNAL HEAD, LED	EACH	4.0
LED SIGNAL FACE RETROFIT, RED BALL	EACH	6.0
LED SIGNAL FACE RETROFIT, GREEN BALL	EACH	5.0
LED SIGNAL FACE RETROFIT, GREEN ARROW	EACH	6.0
ELECTRIC CABLE IN CONDUIT, 1/C, NO. 6 GROUNDING	FOOT	460.5
BOND TRAFFIC SIGNAL STRUCTURE	EACH	10.0
MODIFY EXISTING CONTROLLER CABINET	EACH	1.0
ADJUST EXISTING DETECTOR LOOP RISER	EACH	6.0

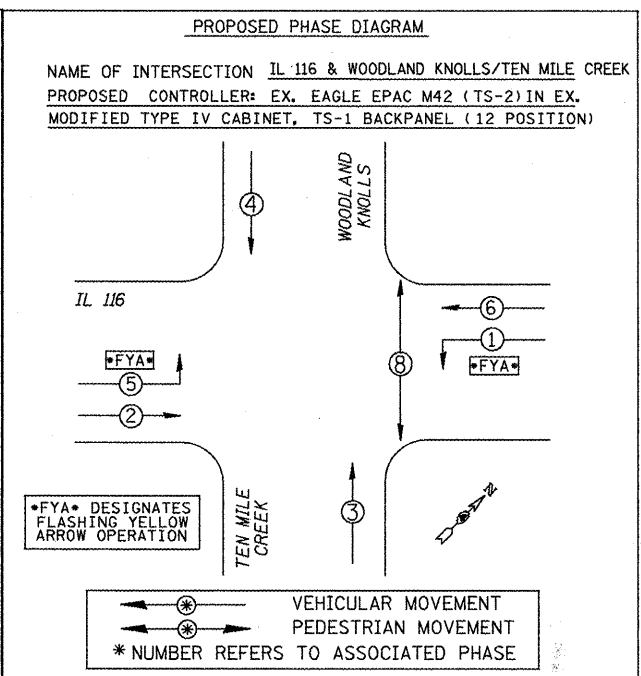
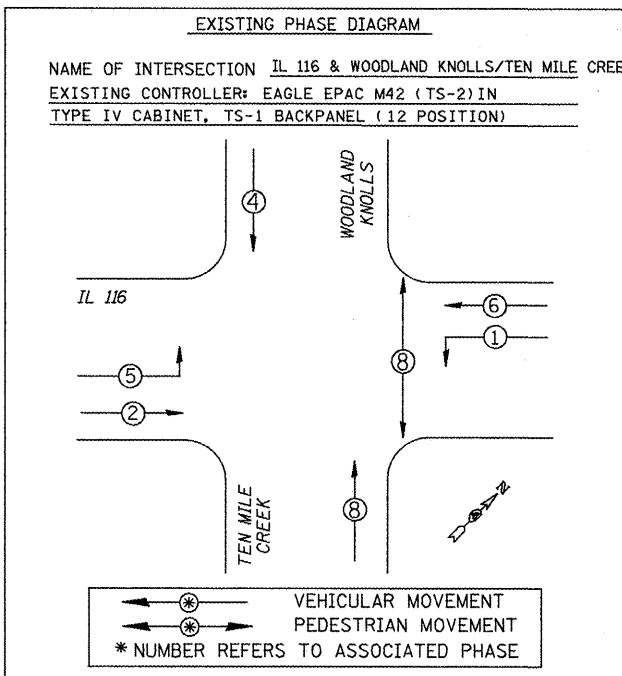

DETECTOR LOOP AND DETECTOR ASSIGNMENT SCHEDULE - IL 116 & WOODLAND KNOLLS/TEN MILE CREEK RD.

DETECTOR LOOP	TYPE	DETECTOR LOOP QTY.	DETECTOR LEAD-IN QTY.	ASSIGNED PHASE	ADJUST LOOP RISER	COMMENTS
D-1	6' X 50' QUAD	162	6	1	1	IL 116 WESTBOUND LEFT TURN LANE (ONTO TEN MILE CREEK RD.)
D-2A	6' X 6'	24	15	2	1	IL 116 EASTBOUND (LEFT LANE)
D-2B	6' X 6'	24	8	2		IL 116 EASTBOUND (RIGHT LANE)
D-3A	6' X 50' QUAD	162	20	3	1	TEN MILE CREEK RD. NORTHBOUND (LEFT TURN/THRU LANE)/EX. D-8A
D-3B	6' X 50' QUAD	162	10	3		TEN MILE CREEK RD. NORTHBOUND (RIGHT TURN LANE)/EX. D-8B
D-4A	6' X 50' QUAD	162	20	4	1	WOODLAND KNOLLS SOUTHBOUND (LEFT TURN/THRU LANE)
D-4B	6' X 50' QUAD	162	10	4		WOODLAND KNOLLS SOUTHBOUND (RIGHT TURN LANE)
D-5	6' X 50' QUAD	162	6	5	1	IL 116 EASTBOUND LEFT TURN LANE (ONTO WOODLAND KNOLLS)
D-6A	6' X 6'	24	15	6	1	IL 116 WESTBOUND (LEFT LANE)
D-6B	6' X 6'	24	8	6		IL 116 WESTBOUND (RIGHT LANE)
TOTAL:		1068	118		6	

#1, #7 (MAM)		#6, #11 (BM)		#4, #10 (MAM)		#2, #3, #8, #9, #12 (MAM)		#5 (MAM)	
EX.	PROP.	EX.	PROP.	EX.	PROP.	EX.	PROP.	EX.	PROP.
(7)	(7)	(7)	(7)	(5)	(5)	(5)	(5)	(5)	(5)
R	R	R	R	R	R	R	R	R	R
Y	Y	Y	Y	Y	Y	Y	Y	Y	Y
G	G	G	G	G	G	G	G	G	G
Y/G	Y/G	Y/G	Y/G	Y/G	Y/G	Y/G	Y/G	Y/G	Y/G

INSTALL NEW 5/C CABLE FOR MAM HEADS #2, #3 (JUMPER) AND #8, #9 (JUMPER) RETROFIT NEW LED MODULES

TRAFFIC SIGNALS SHEET 6 OF 15

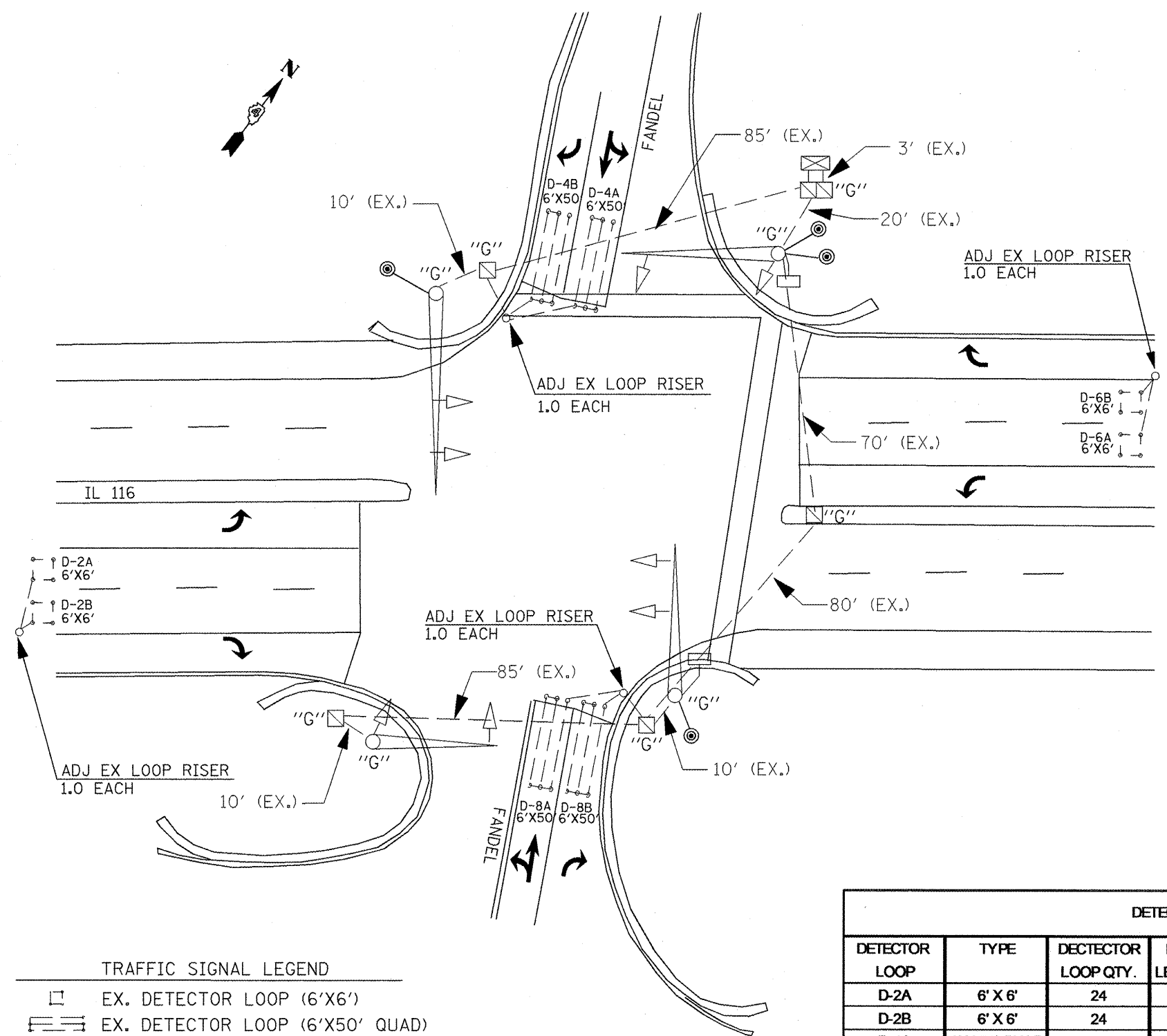
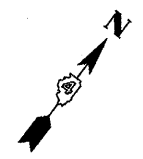

STRUCTURES TO BE SAFETY BONDED			
DOUBLE HANDHOLE	HANDHOLE	MAST ARM	SERVICE RISER
1	4	4	1

NOTE: ONLY HANDHOLES WITH LINE VOLTAGE CONDUCTORS SHALL BE GROUNDED. DETECTOR LOOP AND TRAFFIC SIGNAL INTERCONNECT HANDHOLES WILL TYPICALLY NOT REQUIRE GROUNDING.

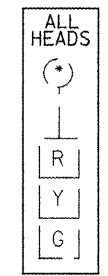

SCHEDULE OF QUANTITIES IL 116 & FANDEL		
DETECTOR LOOP, TYPE I	FOOT	850.0
PEDESTRIAN PUSH-BUTTON	EACH	4.0
LED SIGNAL FACE RETROFIT, RED BALL	EACH	8.0
LED SIGNAL FACE RETROFIT, GREEN BALL	EACH	8.0
ELECTRIC CABLE IN CONDUIT, 1/C, NO. 6 GROUNDING	FOOT	429.0
BOND TRAFFIC SIGNAL STRUCTURE	EACH	9.0
ADJUST EXISTING DETECTOR LOOP RISER	EACH	4.0

- TRAFFIC SIGNAL LEGEND**
- EX. DETECTOR LOOP (6'X6')
 - EX. DETECTOR LOOP (6'X50' QUAD)
 - EX. CONTROLLER CABINET
 - EX. HANDHOLE
 - EX. CONDUIT
 - EX. ELECTRICAL SERVICE
 - EX. TRAFFIC SIGNAL HEAD
 - PROP. SIGNAL HEAD (REBUILT)
 - EX. STRUCTURE TO BE SAFETY BONDED
 - PROP. PEDESTRIAN PUSHBUTTON

DETECTOR LOOP AND DETECTOR ASSIGNMENT SCHEDULE - IL 116 & FANDEL						
DETECTOR LOOP	TYPE	DETECTOR LOOP QTY.	DETECTOR LEAD-IN QTY.	ASSIGNED PHASE	ADJUST LOOP RISER	COMMENTS
D-2A	6' X 6'	24	15	2	1	IL 116 EASTBOUND (LEFT LANE)
D-2B	6' X 6'	24	8	2		IL 116 EASTBOUND (RIGHT LANE)
D-4A	6' X 50' QUAD	162	20	4	1	FANDEL SOUTHBOUND (LEFT/THRU LANE)
D-4B	6' X 50' QUAD	162	10	4		FANDEL SOUTHBOUND (RIGHT TURN LANE)
D-6A	6' X 6'	24	15	6	1	IL 116 WESTBOUND (LEFT LANE)
D-6B	6' X 6'	24	8	6		IL 116 WESTBOUND (RIGHT LANE)
D-8A	6' X 50' QUAD	162	20	8	1	FANDEL NORTHBOUND (LEFT/THRU LANE)
D-8B	6' X 50' QUAD	162	10	8		FANDEL NORTHBOUND (RIGHT TURN LANE)
TOTAL:		744	106		4	

TRAFFIC SIGNALS
SHEET 7 OF 15

• 101RS-3; 102RS-4; 103RS-4; 104RS-7 •• TAZEWELL & WOODFORD

FILE NAME = 11116.dgn	USER NAME = hudeisonme	DESIGNED -	REVISED -
		DRAWN -	REVISED -
		CHECKED -	REVISED -
		DATE -	REVISED -

**STATE OF ILLINOIS
DEPARTMENT OF TRANSPORTATION**

**PROPOSED TRAFFIC SIGNALS
IL 116 & FANDEL RD.**

SCALE: Not to Scale SHEET NO. OF SHEETS STA. TO STA.

F.A.P. RTE. 673	SECTION .	COUNTY ..	TOTAL SHEETS 60	SHEET NO. 39
			CONTRACT NO. 68920	
ILLINOIS FED. AID PROJECT				

STRUCTURES TO BE SAFETY BONDED	
HANDHOLE (STD OR HD)	MAST ARM
5	4
NOTE: ONLY HANDHOLES WITH LINE VOLTAGE CONDUCTORS SHALL BE GROUNDED. DETECTOR LOOP AND TRAFFIC SIGNAL INTERCONNECT HANDHOLES WILL TYPICALLY NOT REQUIRE GROUNDING.	

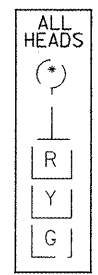
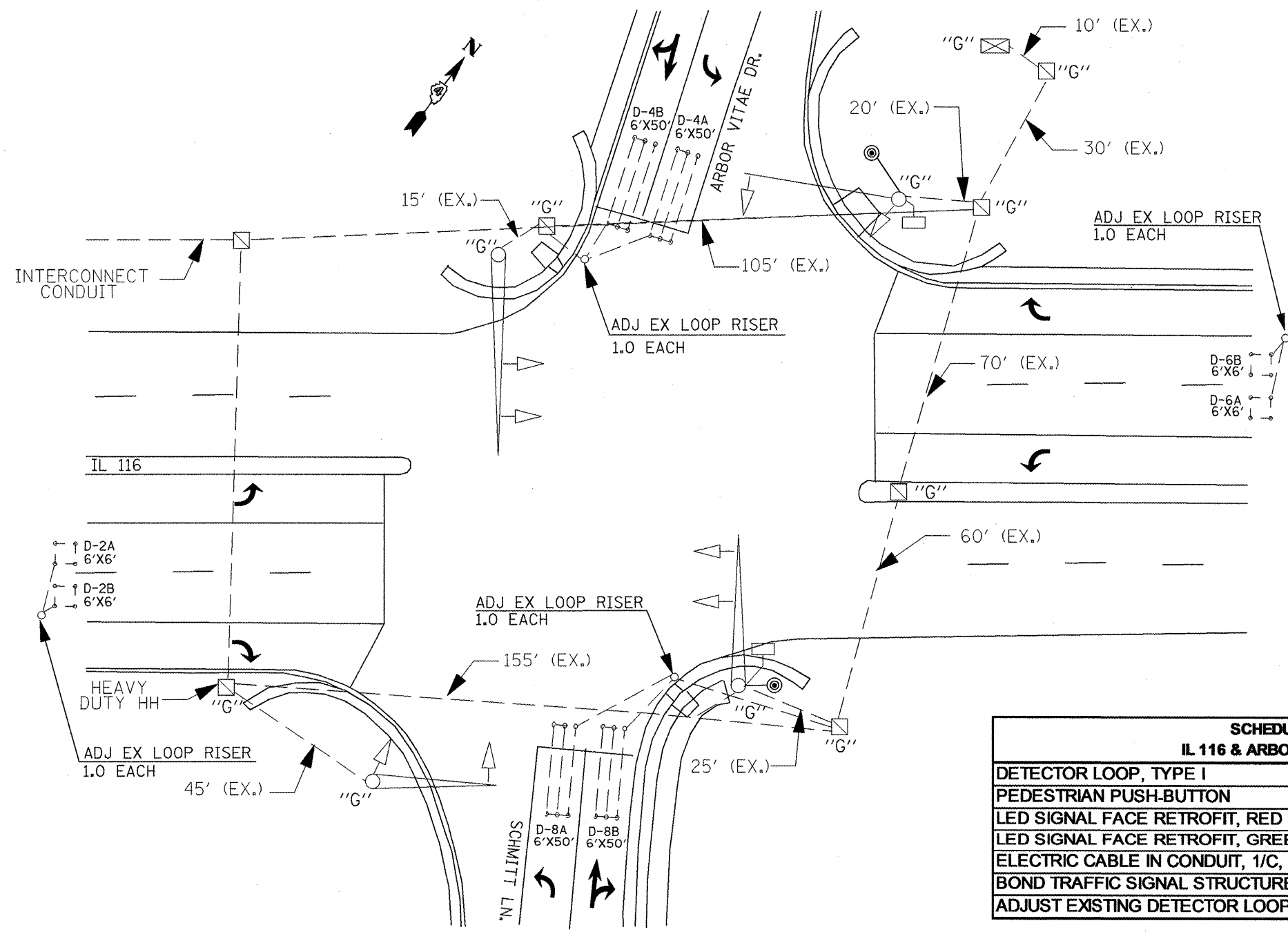

SCHEDULE OF QUANTITIES IL 116 & ARBOR VITAE DR./SCHMITT LN.		
DETECTOR LOOP, TYPE I	FOOT	0.0
PEDESTRIAN PUSH-BUTTON	EACH	2.0
LED SIGNAL FACE RETROFIT, RED BALL	EACH	8.0
LED SIGNAL FACE RETROFIT, GREEN BALL	EACH	8.0
ELECTRIC CABLE IN CONDUIT, 1/C, NO. 6 GROUNDING	FOOT	608.5
BOND TRAFFIC SIGNAL STRUCTURE	EACH	9.0
ADJUST EXISTING DETECTOR LOOP RISER	EACH	4.0

TRAFFIC SIGNAL LEGEND	
	EX. DETECTOR LOOP (6'X6')
	EX. DETECTOR LOOP (6'X50' QUAD)
	EX. CONTROLLER CABINET
	EX. HANDHOLE
	EX. CONDUIT
	EX. ELECTRICAL SERVICE
	EX. TRAFFIC SIGNAL HEAD
	PROP. SIGNAL HEAD (REBUILT)
	EX. STRUCTURE TO BE SAFETY BONDED
	PROP. PEDESTRIAN PUSHBUTTON

DETECTOR LOOP AND DETECTOR ASSIGNMENT SCHEDULE - IL 116 & SCHMITT LN./ARBOR VITAE DR.						
DETECTOR LOOP	TYPE	DETECTOR LOOP QTY.	DETECTOR LEAD-IN QTY.	ASSIGNED PHASE	ADJUST LOOP RISER	COMMENTS
D-2A	6' X 6'	24	15	2	1	IL 116 EASTBOUND (LEFT LANE)
D-2B	6' X 6'	24	8	2		IL 116 EASTBOUND (RIGHT LANE)
D-4A	6' X 50' QUAD	162	20	4	1	ARBOR VITAE SOUTHBOUND (LEFT LANE)
D-4B	6' X 50' QUAD	162	10	4		ARBOR VITAE SOUTHBOUND (RIGHT TURN/THRU LANE)
D-6A	6' X 6'	24	15	6	1	IL 116 WESTBOUND (LEFT LANE)
D-6B	6' X 6'	24	8	6		IL 116 WESTBOUND (RIGHT LANE)
D-8A	6' X 50' QUAD	162	20	8	1	SCHMITT NORTHBOUND (LEFT LANE)
D-8B	6' X 50' QUAD	162	10	8		SCHMITT NORTHBOUND (RIGHT TURN/THRU LANE)
TOTAL:		744	106		4	

TRAFFIC SIGNALS
SHEET 8 OF 15

FILE NAME = i1116.dgn	USER NAME = hudeisonme	DESIGNED -	REVISED -
		DRAWN -	REVISED -
		CHECKED -	REVISED -
		DATE -	REVISED -

STATE OF ILLINOIS
DEPARTMENT OF TRANSPORTATION

PROPOSED TRAFFIC SIGNALS
IL 116 & ARBOR VITAE DR./SCHMITT LN.
SCALE: Not to Scale SHEET NO. OF SHEETS STA. TO STA.

F.A.P. RTE. 673	SECTION	COUNTY	TOTAL SHEETS 60	SHEET NO. 40
			CONTRACT NO. 68920	
ILLINOIS FED. AID PROJECT				

• 101RS-3; 102RS-4; 103RS-4; 104RS-7 • TAZEWELL & WOODFORD

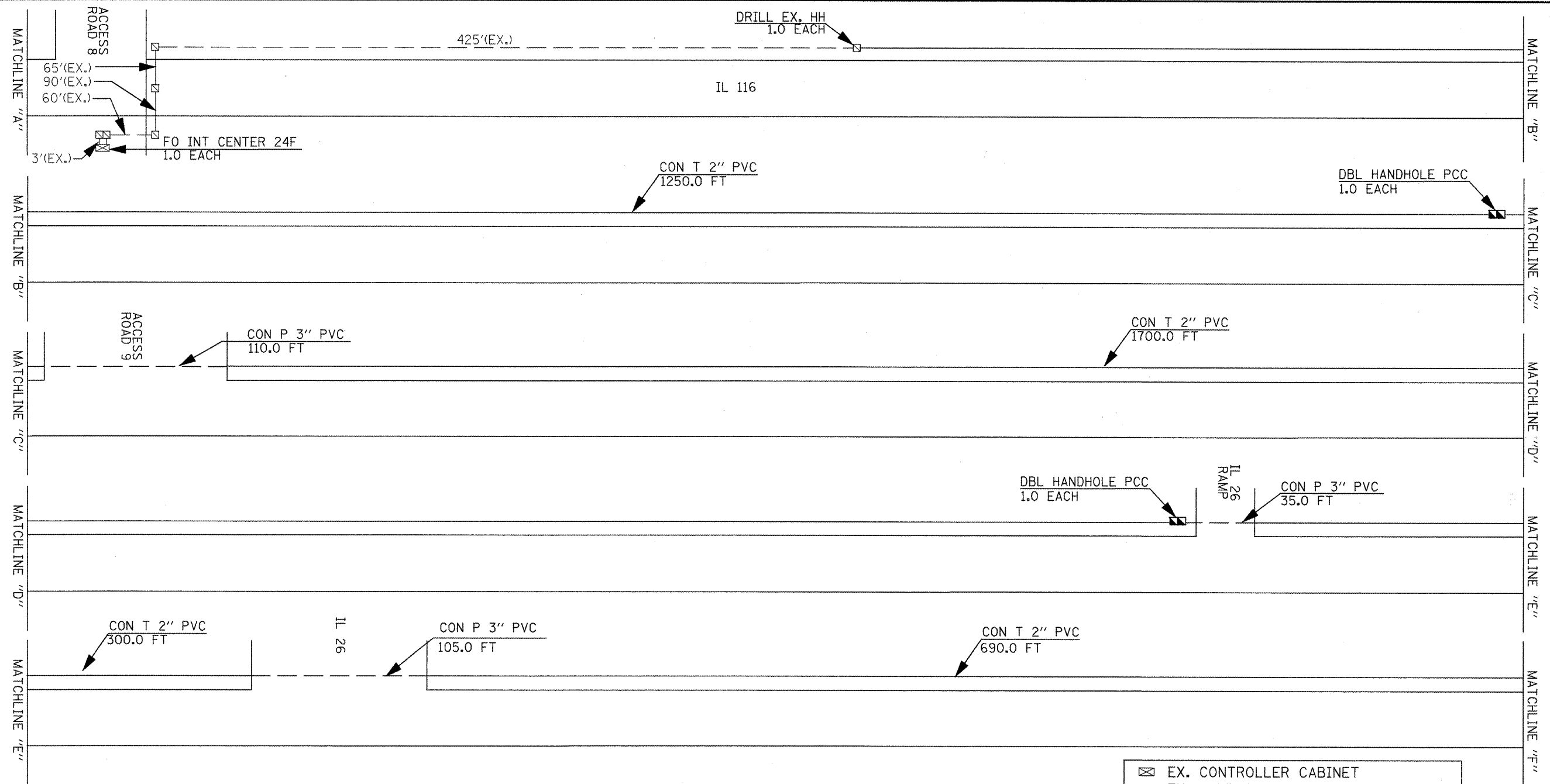

FIBER OPTIC SPLICING REQUIREMENTS

SIX SINGLE MODE CABLES SHALL BE SPLICED TO CREATE A CONTINUOUS FIBER LINK FROM THE SIGNAL CABINET AT IL 116 & ACCESS RD. 8 TO THE SIGNAL CABINET AT IL 116 & ARBOR VITAE DRIVE/SCHMITT LN.
 FOUR SINGLE MODE CABLES SHALL BE SPLICED TO CREATE A CONTINUOUS FIBER LINK FROM THE SIGNAL CABINET AT IL 116 & ACCESS RD. 8 TO THE SIGNAL CABINET AT IL 116 & WOODLAND KNOLLS.
 THE FIBERS AT EACH END OF THE LINKS SHALL BE TERMINATED WITH FUSION SPLICED ST CONNECTORS.
 SIX MULTIMODE FIBERS SHALL BE TERMINATED IN EACH OF THE SIGNAL CABINETS LOCATED ALONG IL 116 AT WOODLAND KNOLLS, FANDEL, AND ARBOR VITAE/SCHMITT LN.

THE DISTANCES SHOWN ARE APPROXIMATE. THE CONTRACTOR SHALL BE RESPONSIBLE FOR VERIFYING THE THE EXISTING FIELD CONDITIONS TO DETERMINE THE ACTUAL LENGTHS REQUIRED PRIOR TO ORDERING AND INSTALLING THE PROPOSED CONDUIT, HANDHOLES, AND FIBER OPTIC CABLE. THE COST OF THIS WORK SHALL BE INCLUDED IN THE BID PRICE FOR THE FIBER OPTIC CABLE.

SLACK CABLE LENGTHS

DOUBLE HANDHOLE:	50.0 FT.
HANDHOLE:	10.0 FT.
CONTROLLER CABINET:	10.0 FT.

- EX. CONTROLLER CABINET
- EX. HANDHOLE
- EX. DOUBLE HANDHOLE
- - EX. CONDUIT
- PROP. DOUBLE HANDHOLE, PCC
- - PROP. CONDUIT, 2" PVC (TRENCHED)
- - PROP. CONDUIT, 3" PVC (PUSHED)
- - PROP. CONDUIT, 2" GALVS ATTACHED TO STRUCTURE

SCHEDULE OF QUANTITIES
ITS FIBER SHEET 1 - IL 116 (ACCESS RD. 8 TO IL 26)

CONDUIT IN TRENCH, 2" DIA, PVC	FOOT	3940.0
CONDUIT PUSHED, 3" DIA, PVC	FOOT	250.0
DOUBLE HANDHOLE, PORTLAND CEMENT CONCRETE	EACH	2.0
TRENCH AND BACKFILL FOR ELECTRICAL WORK	FOOT	3940.0
DRILL EXISTING HANDHOLE	EACH	1.0
FIBER OPTIC INTERCONNECT CENTER, 24 FIBER	EACH	1.0
FIBER OPTIC CABLE IN CONDUIT, 62.5/125, MM12F SM24F	EACH	5033.0

TRAFFIC SIGNALS SHEET 9 OF 15

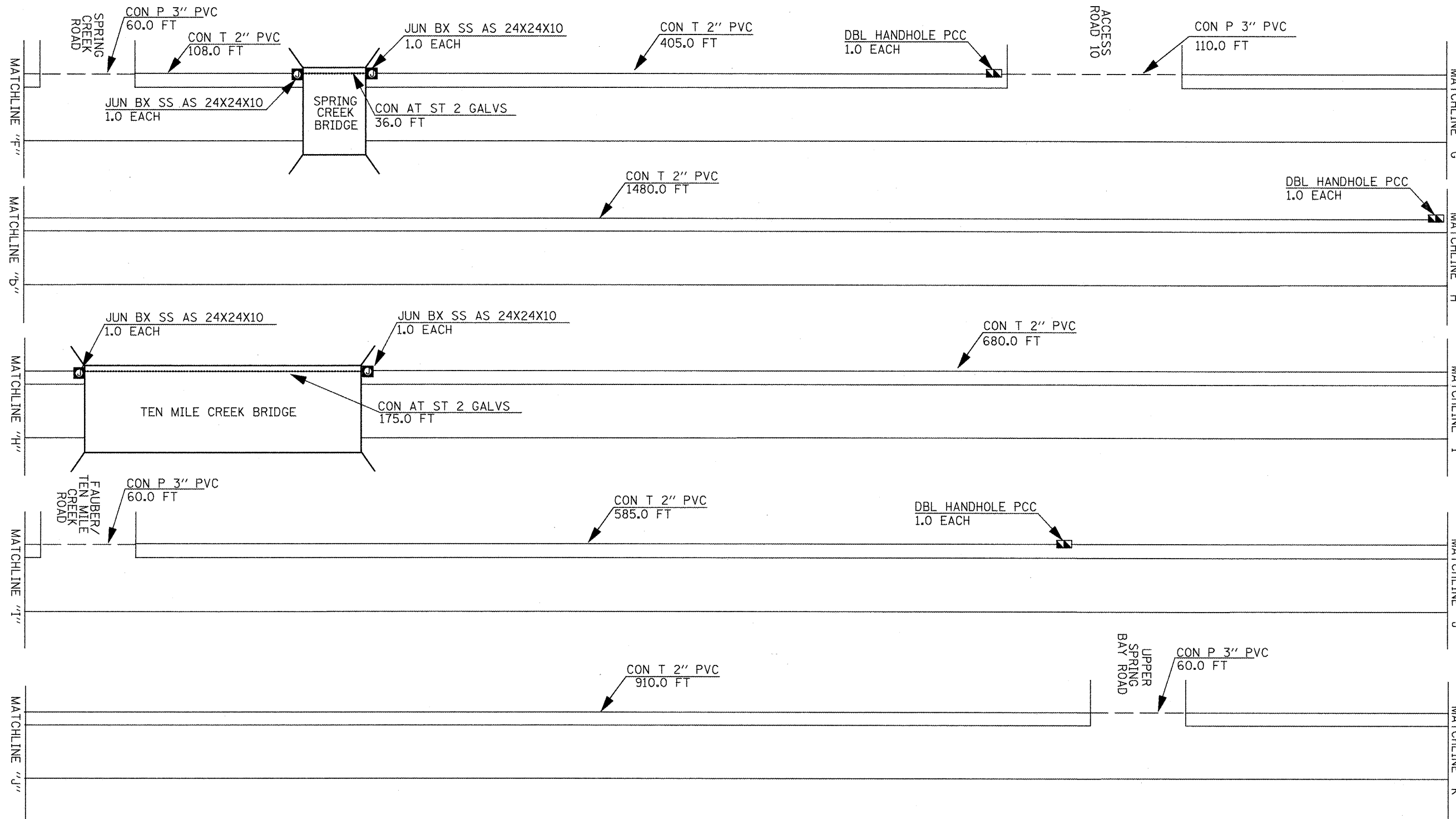

- PROP. JUNCTION BOX, STAINLESS STEEL ATTACHED TO STRUCTURE
- ▣ PROP. DOUBLE HANDHOLE, PCC
- PROP. CONDUIT, 2" PVC (TRENCHED)
- - PROP. CONDUIT, 3" PVC (PUSHED)
- PROP. CONDUIT, 2" GALVS ATTACHED TO STRUCTURE

SLACK CABLE LENGTHS	
DOUBLE HANDHOLE:	50.0 FT.
HANDHOLE:	10.0 FT.
CONTROLLER CABINET:	10.0 FT.
JUNCTION BOX:	6.0 FT.

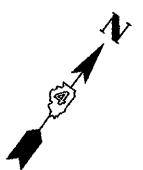

SCHEDULE OF QUANTITIES		
ITS FIBER SHEET 2 - IL 116 (IL 26 TO UPPER SPRING BAY RD.)		
CONDUIT IN TRENCH, 2" DIA, PVC	FOOT	4168.0
CONDUIT PUSHED, 3" DIA, PVC	FOOT	290.0
CONDUIT ATTACHED TO STRUCTURE, 2" DIA, GALV STEEL	FOOT	211.0
JUNCTION BOX, SS, ATTACHED TO STRUCT, 24" X 24" X 10"	EACH	4.0
DOUBLE HANDHOLE, PORTLAND CEMENT CONCRETE	EACH	3.0
TRENCH AND BACKFILL FOR ELECTRICAL WORK	FOOT	4168.0
FIBER OPTIC CABLE IN CONDUIT, 62.5/125, MM12F SM24F	EACH	4843.0

TRAFFIC SIGNALS SHEET 10 OF 15

• 101RS-3; 102RS-4; 103RS-4; 104RS-7 •• TAZEWELL & WOODFORD

FILE NAME = il116.dgn	USER NAME = hudsonme	DESIGNED -	REVISED -
		DRAWN -	REVISED -
	PLOT SCALE = 100,9589' / IN.	CHECKED -	REVISED -
	PLOT DATE = 1/29/2010	DATE -	REVISED -

**STATE OF ILLINOIS
DEPARTMENT OF TRANSPORTATION**

**PROPOSED ITS FIBER AND CONDUIT
SHEET 2 - IL 116 (IL 26 TO UPPER SPRING BAY RD.)**

SCALE: Not to Scale SHEET NO. OF SHEETS STA. TO STA.

F.A.P. RTE. 673	SECTION .	COUNTY ..	TOTAL SHEETS 60	SHEET NO. 42
			CONTRACT NO. 68920	
ILLINOIS FED. AID PROJECT				

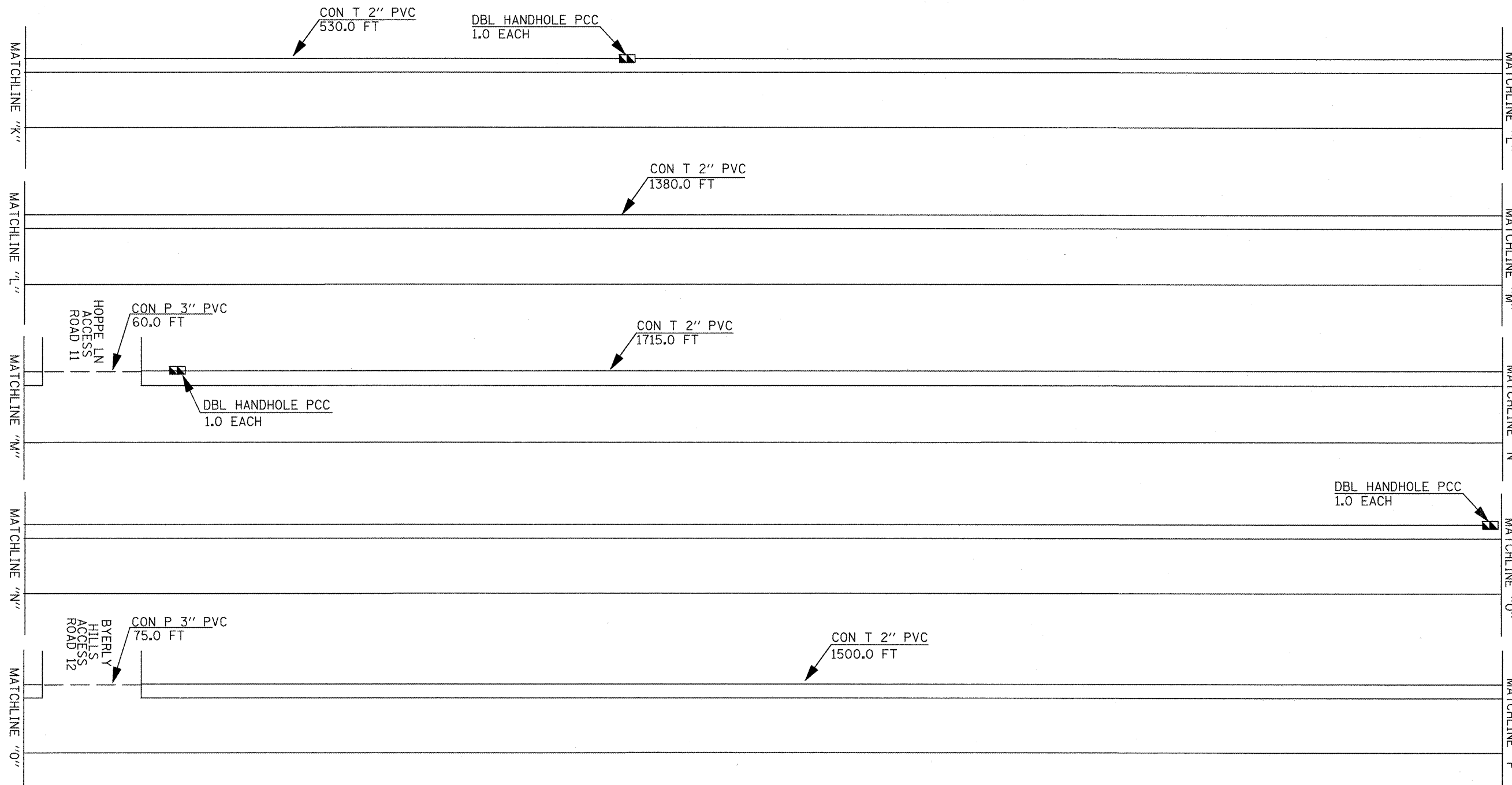

- PROP. JUNCTION BOX, STAINLESS STEEL ATTACHED TO STRUCTURE
- PROP. DOUBLE HANDHOLE, PCC
- PROP. CONDUIT, 2" PVC (TRENCHED)
- PROP. CONDUIT, 3" PVC (PUSHED)
- PROP. CONDUIT, 2" GALVS ATTACHED TO STRUCTURE

SLACK CABLE LENGTHS	
DOUBLE HANDHOLE:	50.0 FT.
HANDHOLE:	10.0 FT.
CONTROLLER CABINET:	10.0 FT.

SCHEDULE OF QUANTITIES		
ITS FIBER SHEET 3 - IL 116 (UPPER SPRING BAY RD. TO BEVERLY HILLS/ACCESS RD. 12)		
CONDUIT IN TRENCH, 2" DIA., PVC	FOOT	5125.0
CONDUIT PUSHED, 3" DIA., PVC	FOOT	135.0
DOUBLE HANDHOLE, PORTLAND CEMENT CONCRETE	EACH	3.0
TRENCH AND BACKFILL FOR ELECTRICAL WORK	FOOT	5125.0
FIBER OPTIC CABLE IN CONDUIT, 62.5/125, MM12F SM24F	EACH	5410.0

TRAFFIC SIGNALS
SHEET 11 OF 15

• 101RS-3; 102RS-4; 103RS-4; 104RS-7 •• TAZEWELL & WOODFORD

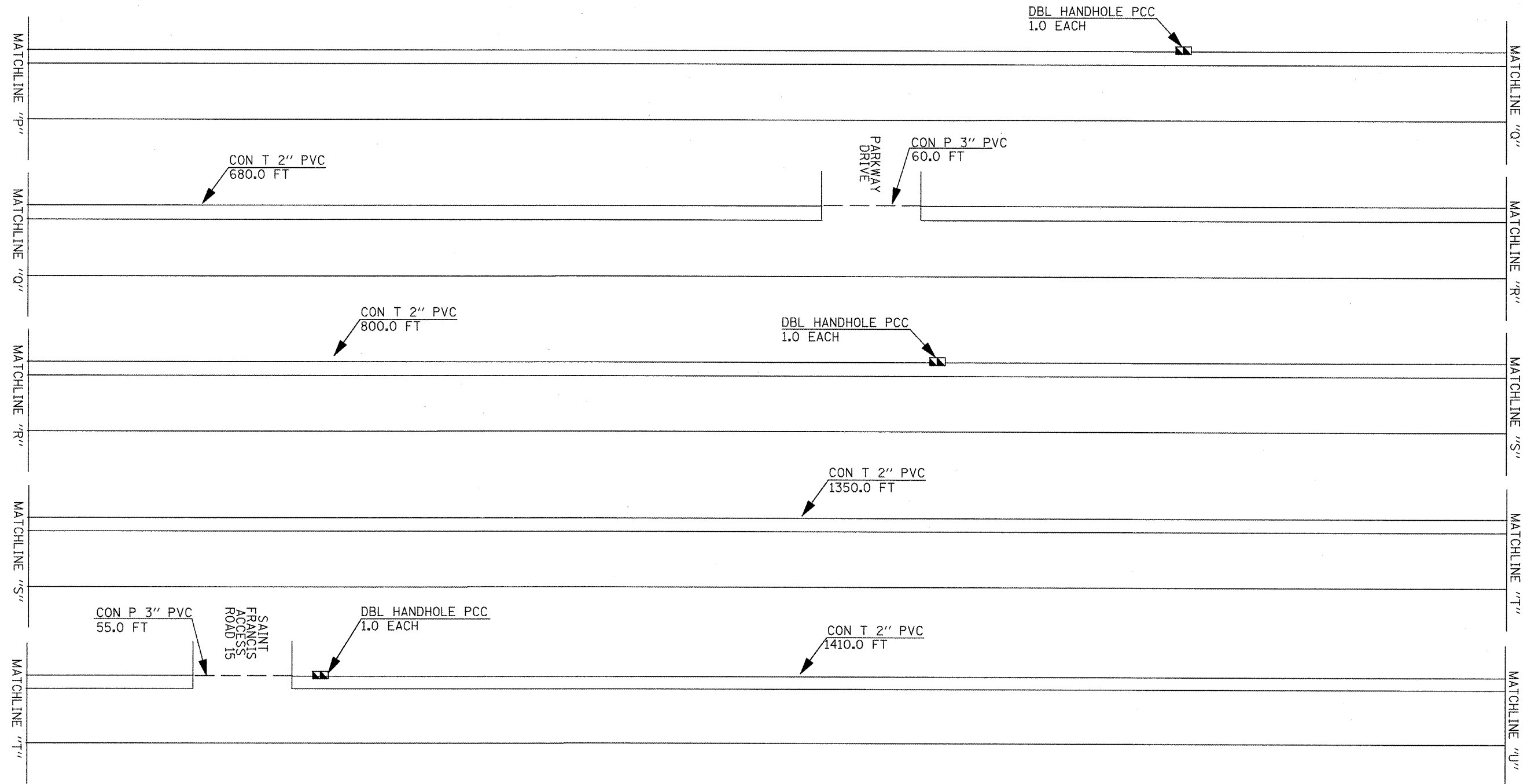

- ☐ PROP. JUNCTION BOX, STAINLESS STEEL ATTACHED TO STRUCTURE
- ▣ PROP. DOUBLE HANDHOLE, PCC
- PROP. CONDUIT, 2" PVC (TRENCHED)
- - PROP. CONDUIT, 3" PVC (PUSHED)
- PROP. CONDUIT, 2" GALVS ATTACHED TO STRUCTURE

SLACK CABLE LENGTHS	
DOUBLE HANDHOLE:	50.0 FT.
HANDHOLE:	10.0 FT.
CONTROLLER CABINET:	10.0 FT.

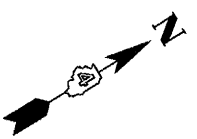

SCHEDULE OF QUANTITIES		
ITS FIBER SHEET 4 - IL 116 (BEV HILLS/ACCESS RD. 12 TO ST FRANCIS/ACCESS RD. 15)		
CONDUIT IN TRENCH, 2" DIA., PVC	FOOT	4240.0
CONDUIT PUSHED, 3" DIA., PVC	FOOT	115.0
DOUBLE HANDHOLE, PORTLAND CEMENT CONCRETE	EACH	3.0
TRENCH AND BACKFILL FOR ELECTRICAL WORK	FOOT	4240.0
FIBER OPTIC CABLE IN CONDUIT, 62.5/125, MM12F SM24F	EACH	4505.0

TRAFFIC SIGNALS
SHEET 12 OF 15

FILE NAME = 11116.dgn	USER NAME = hudelsonno	DESIGNED -	REVISED -
		DRAWN -	REVISED -
		CHECKED -	REVISED -
		DATE -	REVISED -

STATE OF ILLINOIS
DEPARTMENT OF TRANSPORTATION

PROPOSED ITS FIBER AND CONDUIT
SHEET 4 - IL 116 (BYLY HILLS/ACCESS RD. 12 TO ST. FRAN/ACCESS RD. 15)

F.A.P. RTE. 673	SECTION	COUNTY	TOTAL SHEETS 60	SHEET NO. 44
SCALE: Not to Scale			CONTRACT NO. 68920	
ILLINOIS FED. AID PROJECT				

* 101RS-3; 102RS-4; 103RS-4; 104RS-7 ** TAZEVELL & WOODFORD

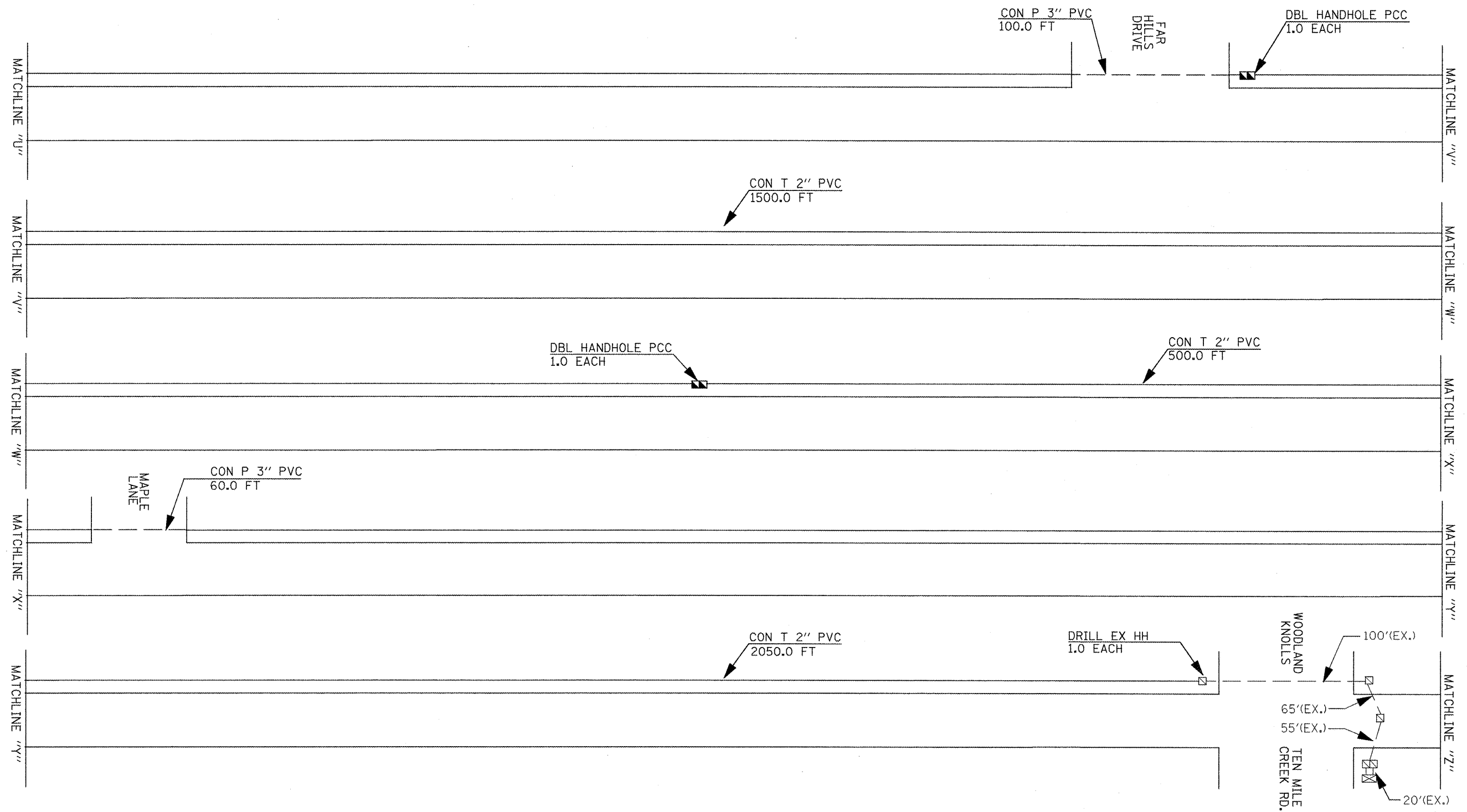

- EX. CONTROLLER CABINET
- EX. HANDHOLE
- EX. DOUBLE HANDHOLE
- EX. CONDUIT
- PROP. DOUBLE HANDHOLE, PCC
- PROP. CONDUIT, 2" PVC (TRENCHED)
- PROP. CONDUIT, 3" PVC (PUSHED)
- PROP. CONDUIT, 2" GALVS ATTACHED TO STRUCTURE

SLACK CABLE LENGTHS
 DOUBLE HANDHOLE: 50.0 FT.
 HANDHOLE: 10.0 FT.
 CONTROLLER CABINET: 10.0 FT.

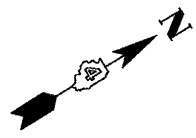

SCHEDULE OF QUANTITIES		
ITS FIBER SHEET 5 - IL 116 (ST FRANCIS/ACCESS RD. 15 TO WOODLAND KNOLLS)		
CONDUIT IN TRENCH, 2" DIA, PVC	FOOT	4050.0
CONDUIT PUSHED, 3" DIA, PVC	FOOT	160.0
DOUBLE HANDHOLE, PORTLAND CEMENT CONCRETE	EACH	2.0
TRENCH AND BACKFILL FOR ELECTRICAL WORK	FOOT	4050.0
DRILL EXISTING HANDHOLE	EACH	1.0
FIBER OPTIC CABLE IN CONDUIT, 62.5/125, MM12F SM24F	EACH	4643.0

TRAFFIC SIGNALS
SHEET 13 OF 15

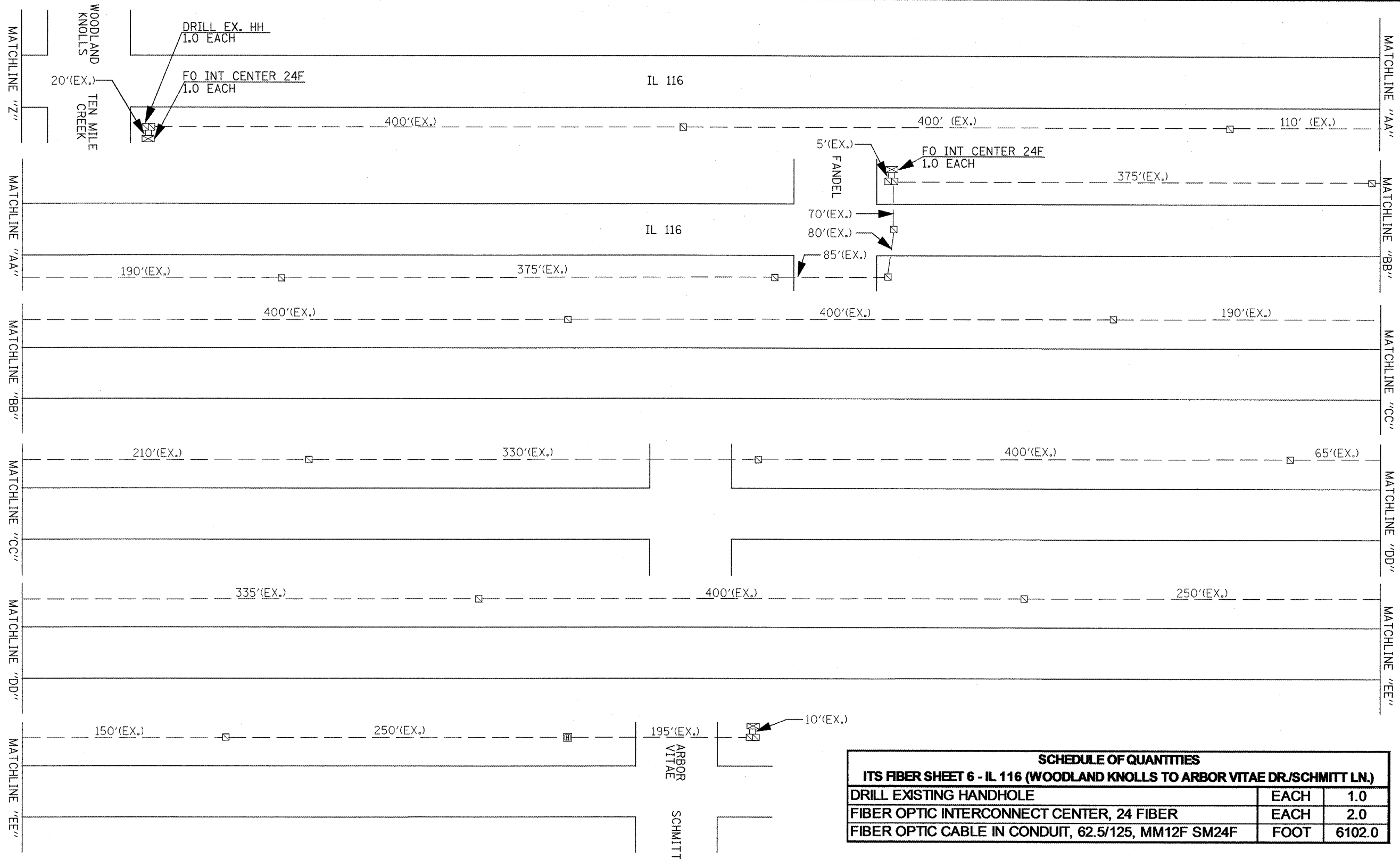

SCHEDULE OF QUANTITIES		
ITS FIBER SHEET 6 - IL 116 (WOODLAND KNOLLS TO ARBOR VITAE DR/SCHMITT LN.)		
DRILL EXISTING HANDHOLE	EACH	1.0
FIBER OPTIC INTERCONNECT CENTER, 24 FIBER	EACH	2.0
FIBER OPTIC CABLE IN CONDUIT, 62.5/125, MM12F SM24F	FOOT	6102.0

- NOTES: 1. PROPOSED FIBER OPTIC CABLE TO BE INSTALLED IN EXISTING INTERCONNECT CONDUIT AND HANDHOLES.
 2. SPACING BETWEEN INTERCONNECT CONDUIT HANDHOLES IS TYPICALLY APPROXIMATELY 400 FT.
 3. THE DISTANCES SHOWN ARE APPROXIMATE. THE CONTRACTOR SHALL BE RESPONSIBLE FOR MEASURING THE EXISTING CONDUIT RUNS TO DETERMINE THE ACTUAL LENGTHS PRIOR TO ORDERING AND INSTALLING THE PROPOSED FIBER OPTIC CABLE. THE COST OF THIS WORK SHALL BE INCLUDED IN THE BID PRICE FOR THE FIBER OPTIC CABLE. THERE WILL BE NO ADDITIONAL COMPENSATION FOR THIS WORK.
 4. TRACER WIRE IS NOT REQUIRED IN THIS EXISTING CONDUIT RUN.

- ☒ EX. CONTROLLER CABINET
- ☐ EX. HANDHOLE
- ☒ EX. DOUBLE HANDHOLE
- EX. CONDUIT

SLACK CABLE LENGTHS
 DOUBLE HANDHOLE: 50.0 FT.
 HANDHOLE: 10.0 FT.
 CONTROLLER CABINET: 10.0 FT.

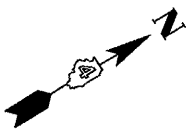

101RS-3; 102RS-4; 103RS-4; 104RS-7 ** TAZEWELL & WOODFORD

TRAFFIC SIGNALS
 SHEET 14 OF 15

FILE NAME = 11116.dgn	USER NAME = hudsonme	DESIGNED -	REVISED -
		DRAWN -	REVISED -
	PLOT SCALE = 100.9589' / IN.	CHECKED -	REVISED -
	PLOT DATE = 1/29/2010	DATE -	REVISED -

**STATE OF ILLINOIS
 DEPARTMENT OF TRANSPORTATION**

**PROPOSED ITS FIBER AND CONDUIT
 SHEET 6 - IL 116 (WOODLAND KNOLLS TO ARBOR VITAE/SCHMITT)**

SCALE: Not to Scale SHEET NO. OF SHEETS STA. TO STA.

F.A.P. RTE. 673	SECTION .	COUNTY ..	TOTAL SHEETS 60	SHEET NO. 16
CONTRACT NO. 68920				
ILLINOIS FED. AID PROJECT				

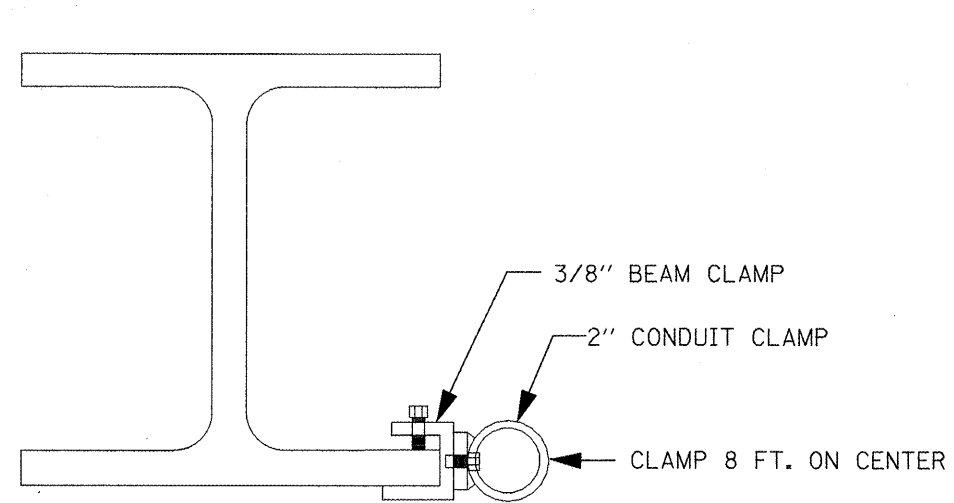

CONDUIT ATTACHMENT DETAIL

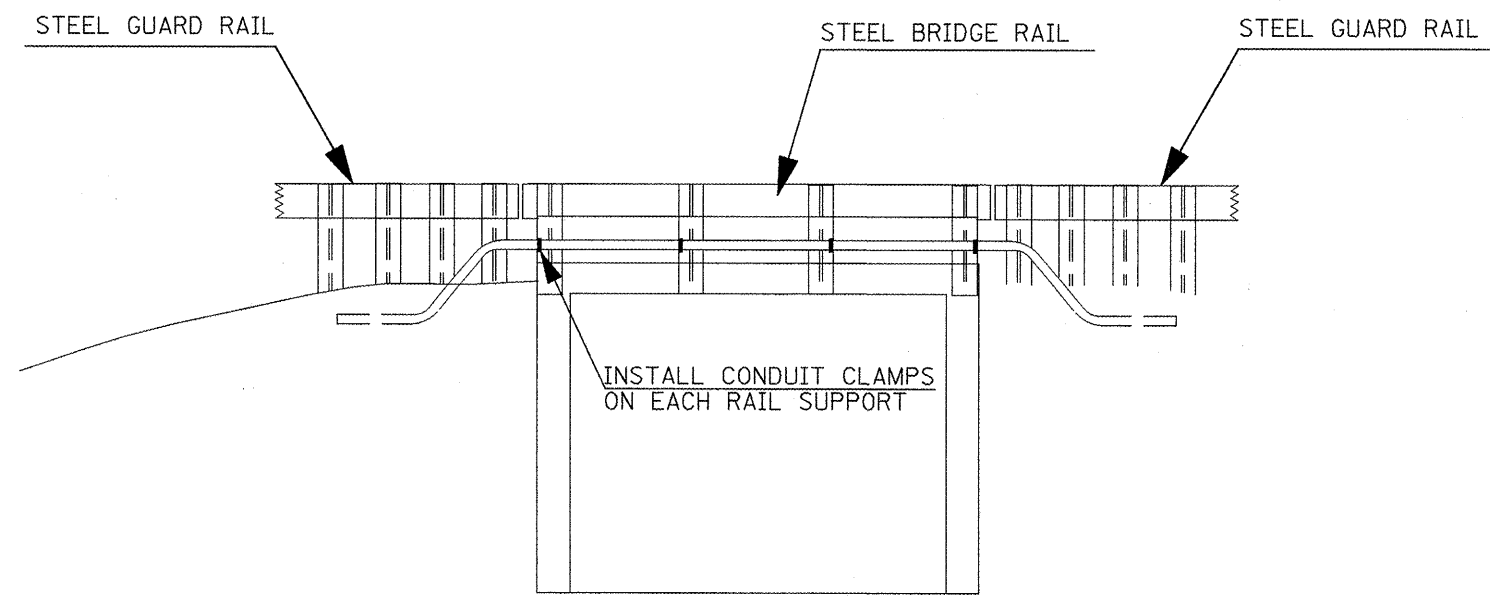

IL 116 BRIDGE OVER SPRING CREEK

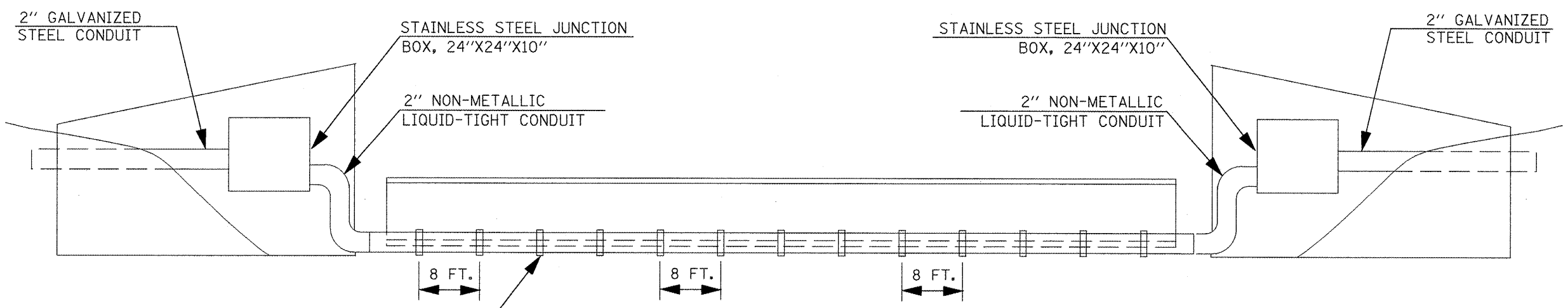

IL 116 BRIDGE OVER TEN MILE CREEK

• 101RS-3; 102RS-4; 103RS-4; 104RS-7 •• TAZEVELL & WOODFORD

TRAFFIC SIGNALS
SHEET 15 OF 15

FILE NAME = i1116.dgn	USER NAME = hudeisonme	DESIGNED -	REVISED -
		DRAWN -	REVISED -
		CHECKED -	REVISED -
		DATE -	REVISED -

STATE OF ILLINOIS
DEPARTMENT OF TRANSPORTATION

CONDUIT ATTACHED TO STRUCTURE
INSTALLATION DETAILS
SCALE: Not to Scale SHEET NO. OF SHEETS STA. TO STA.

F.A.P. RTE. 673	SECTION .	COUNTY ..	TOTAL SHEETS 60	SHEET NO. 47
			CONTRACT NO. 68920	
ILLINOIS FED. AID PROJECT				

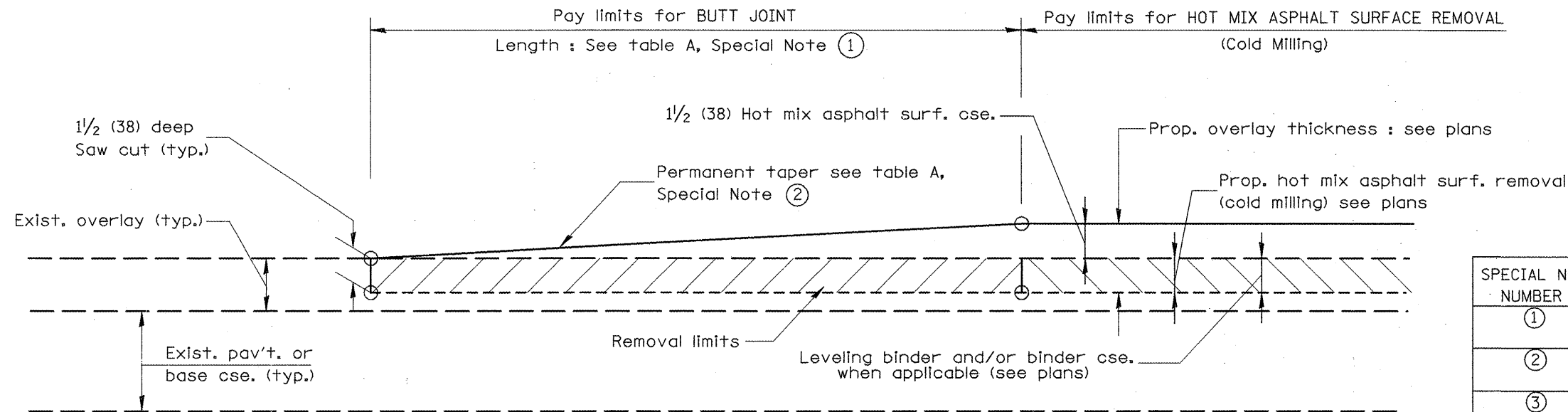

CASE 1 : WITH HOT MIX ASPHALT SURFACE REMOVAL (COLD MILLING)

TABLE A
(LENGTHS AND TAPER RATES)

SPECIAL NOTE NUMBER	ELEMENT	MAINLINE INTERSTATES & 4-LANE EXPRESSWAYS	ALL OTHERS
①	LENGTH OF BUTT JOINT	60'(18.0 m)	30'(9.0 m)
②	PERMANENT TAPER RATE	1:480	1:240
③	TEMPORARY RAMP TAPER RATE	1:80	1:40
④	TEMPORARY RAMP LENGTH	10'(3.0 m)	5'(1.5 m)
⑤	LENGTH OF BUTT JOINT	10'(3.0 m)	10'(3.0 m)

GENERAL NOTES

1. The work shall be done in accordance with Article 406.08 and the Special Provision for Butt Joints.
2. The pavement surface to be removed may be either bituminous or P.C. concrete. The work shall be performed in accordance with Article 440.04 and the Special Provisions for Butt Joints.
3. The saw cut joints shall be primed just prior to the placing of bituminous material. The work will be in accordance with the applicable portions of Article 406.05.

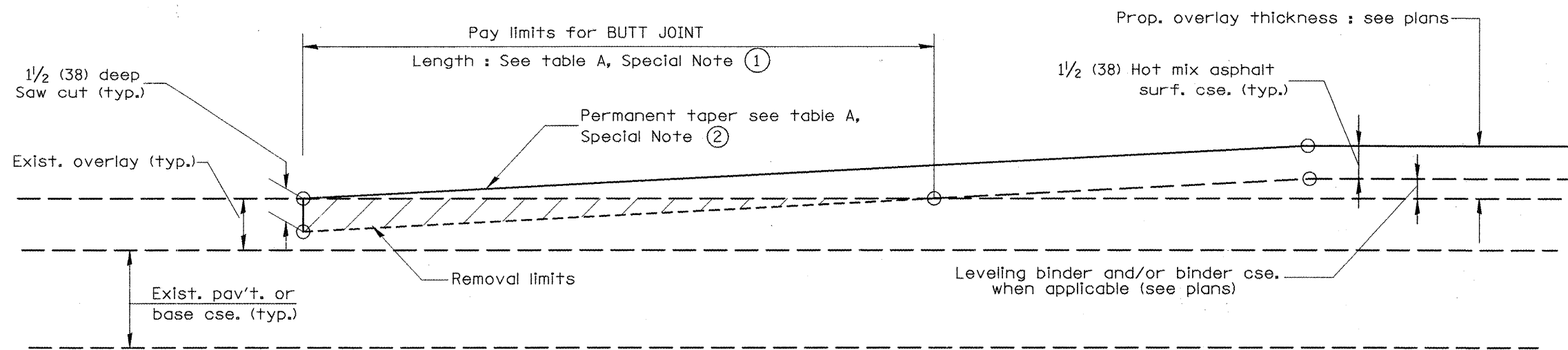

CASE 2 : NO HOT MIX ASPHALT SURFACE REMOVAL (COLD MILLING)

All dimensions are in inches (millimeters) unless otherwise noted.

01-01-97	RENUM. C-23.01, NEW REVISION BOX	T.P.
04-01-97	CORRECTION TO DEPTH	J.A.
09-15-05	REVISED DESIGNER NOTE	M.M.A.
10-16-06	REVISED TO 2007 SPEC.	M.A.

STATE OF ILLINOIS
DEPARTMENT OF TRANSPORTATION

BUTT JOINTS

NOT TO SCALE

SHT. 1 OF 3
CADD STD. 406101-D4

F.A.P. RTE.	SECTION	COUNTY	TOTAL SHEETS	SHEET NO.
673	**	TAZE/WOOD	60	48
FED. ROAD DIST. NO.			CONTRACT NO. 68920	
ILLINOIS FED. AID PROJECT				

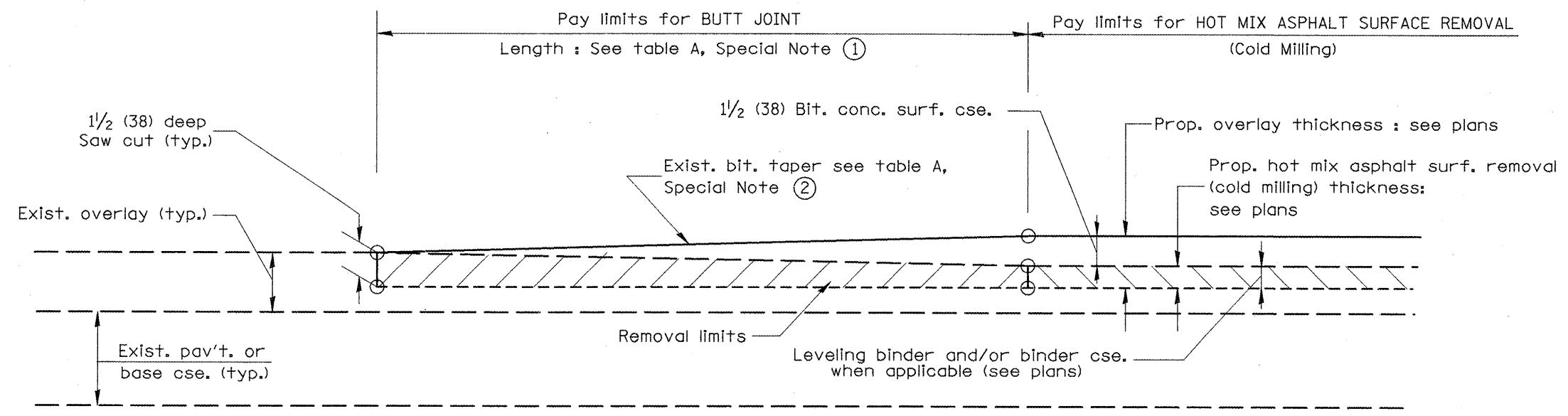

**CASE 3 : WITH HOT MIX ASPHALT SURFACE REMOVAL (COLD MILLING)
TIE-IN TO EXISTING BITUMINOUS TAPER**

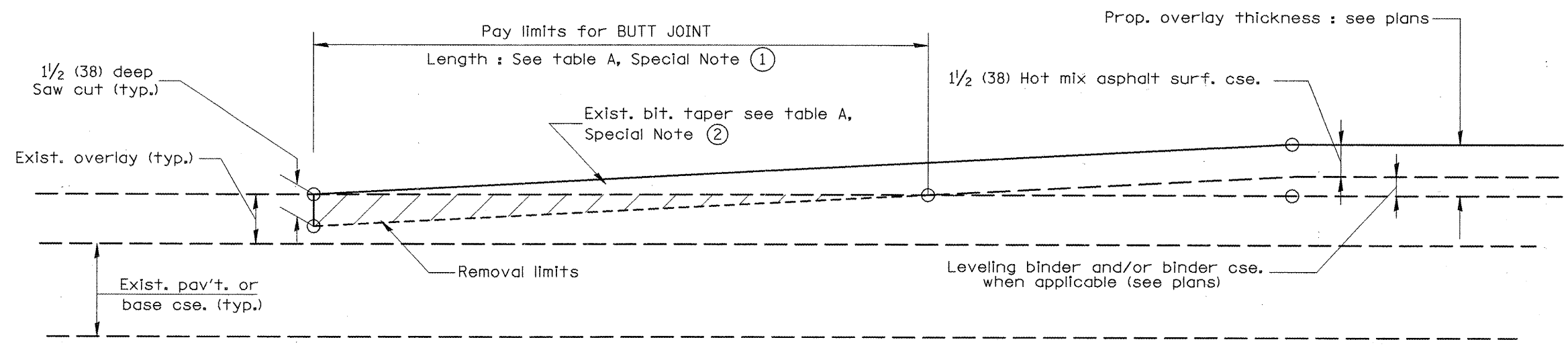

**CASE 4 : NO HOT MIX ASPHALT SURFACE REMOVAL (COLD MILLING)
TIE-IN TO EXISTING BITUMINOUS TAPER**

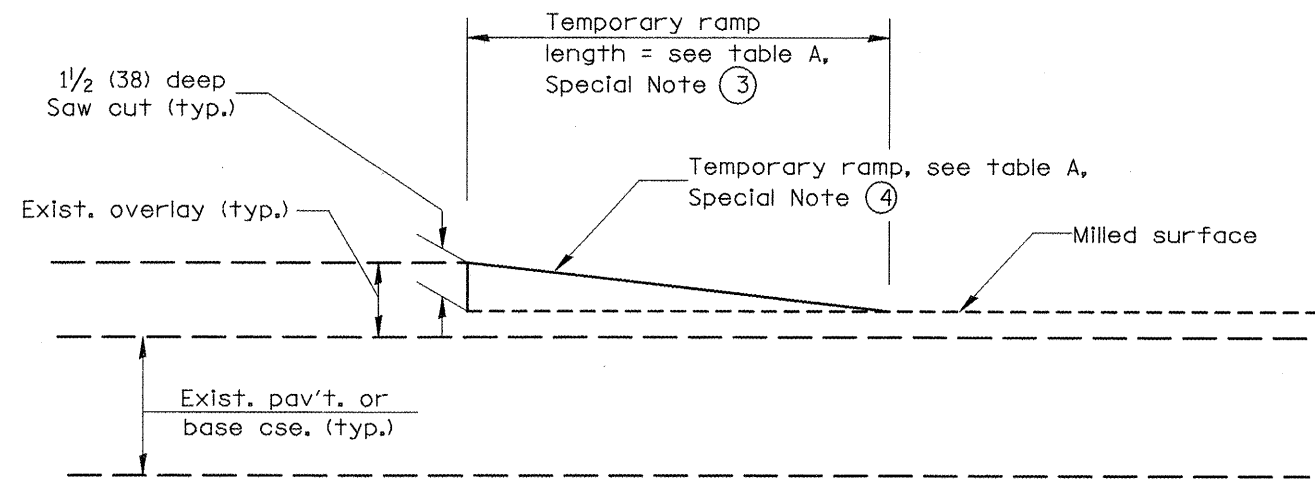

DETAIL TEMPORARY RAMP

All dimensions are in inches (millimeters)
unless otherwise noted.

--	--	--	--	--	--	--	--	--	--

STATE OF ILLINOIS
DEPARTMENT OF TRANSPORTATION

BUTT JOINTS
NOT TO SCALE

F.A.P. RTE.	SECTION	COUNTY	TOTAL SHEETS	SHEET NO.
673	..	TAZE/WOOD	60	49

SHT. 2 OF 3
CADD STD. 406101-04

FED. ROAD DIST. NO. ILLINOIS FED. AID PROJECT CONTRACT NO. 68920

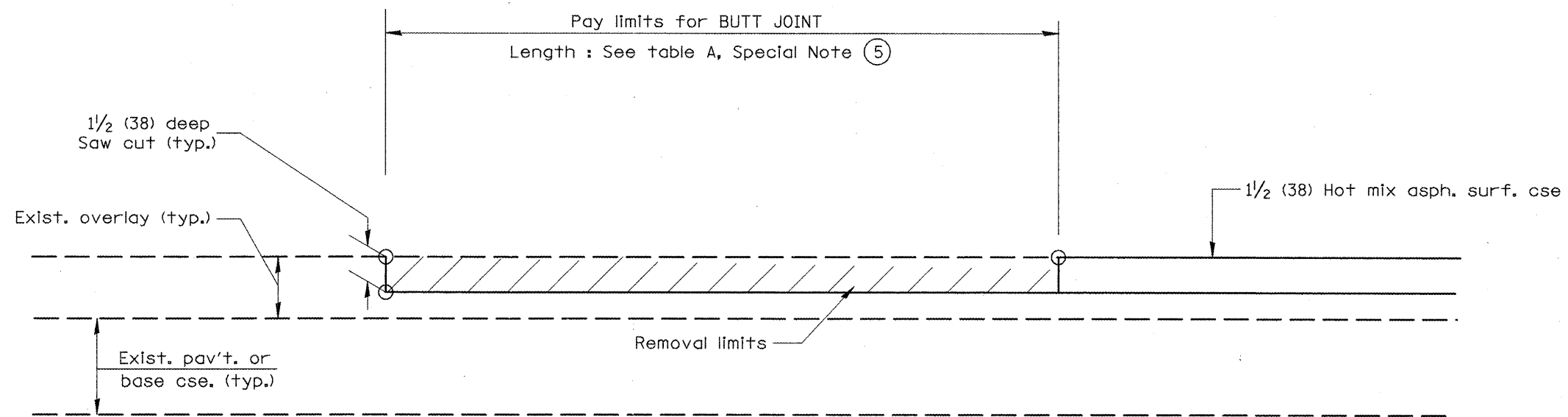

**CASE 5 : WITH HOT MIX ASPHALT SURFACE REMOVAL (COLD MILLING)
TIE-IN TO EXISTING BITUMINOUS TAPER**

All dimensions are in inches (millimeters) unless otherwise noted.

•• 101RS-3; 102RS-4; 103RS-4; 104RS-7

**STATE OF ILLINOIS
DEPARTMENT OF TRANSPORTATION**

BUTT JOINTS

NOT TO SCALE

SHT. 3 OF 3
CADD STD. 406101-D4

F.A.P. RTE.	SECTION	COUNTY	TOTAL SHEETS	SHEET NO.
673	••	TAZE/WOOD	60	50
FED. ROAD DIST. NO. ILLINOIS FED. AID PROJECT			CONTRACT NO. 68920	

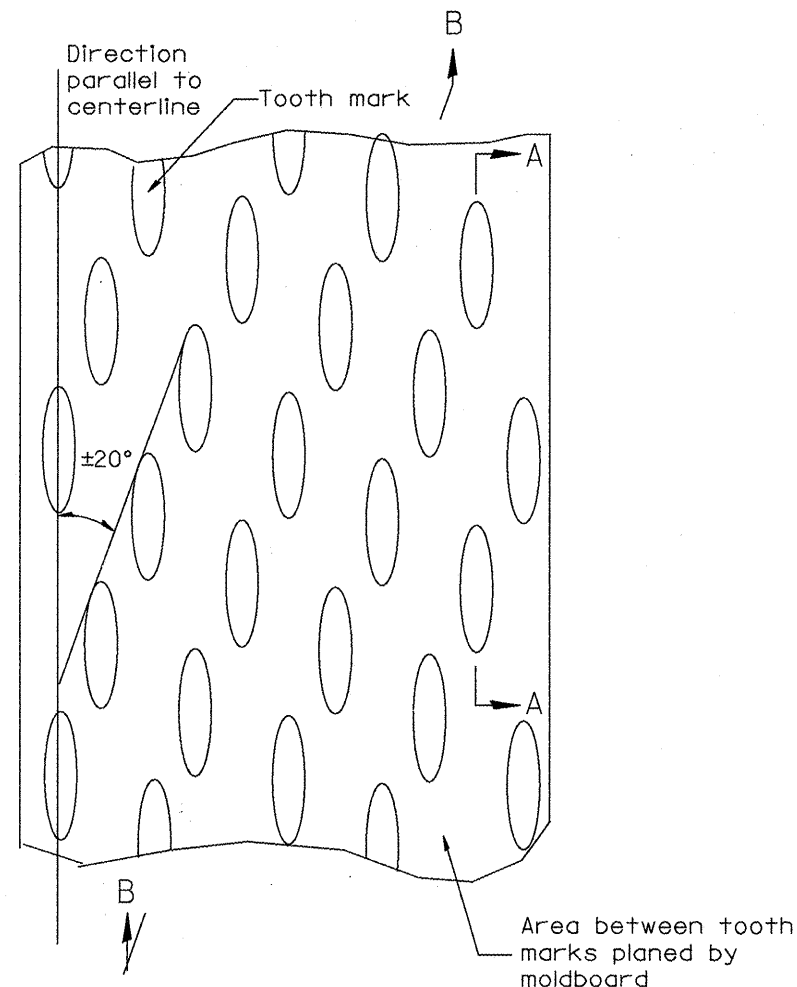

PLAN

General notes:

1. Coldmilling shall consist of two processes: Cutting with carbide teeth mounted on a rotating drum, and planing with a moldboard mounted immediately behind the cutting drum.
2. Other similar patterns will be acceptable if they consist of a smooth, flat, planed surface interspersed with a pattern of discontinuous longitudinal striations.

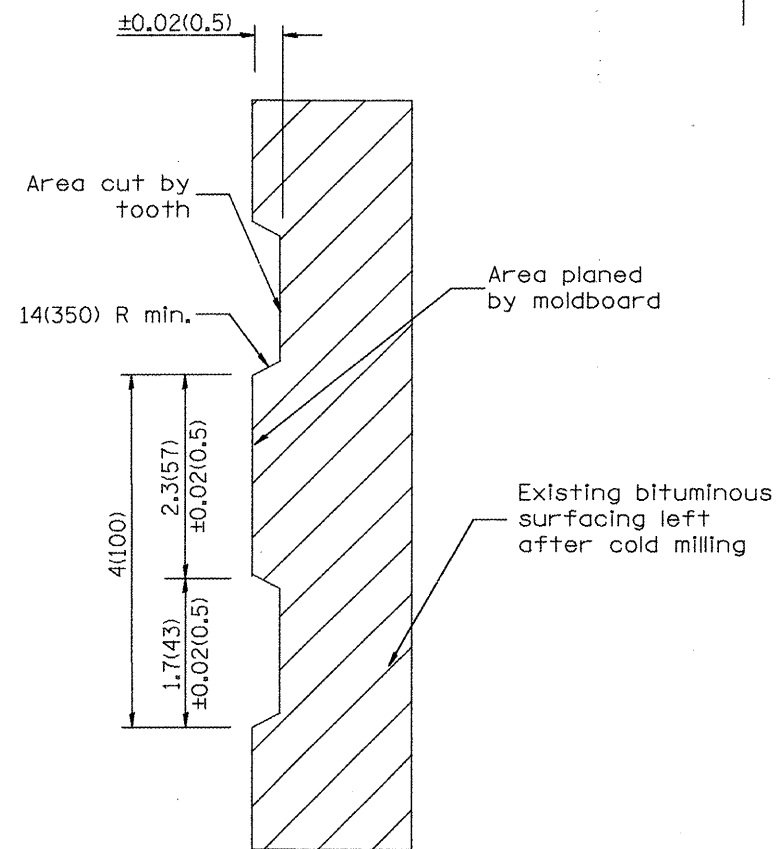

SECTION A-A

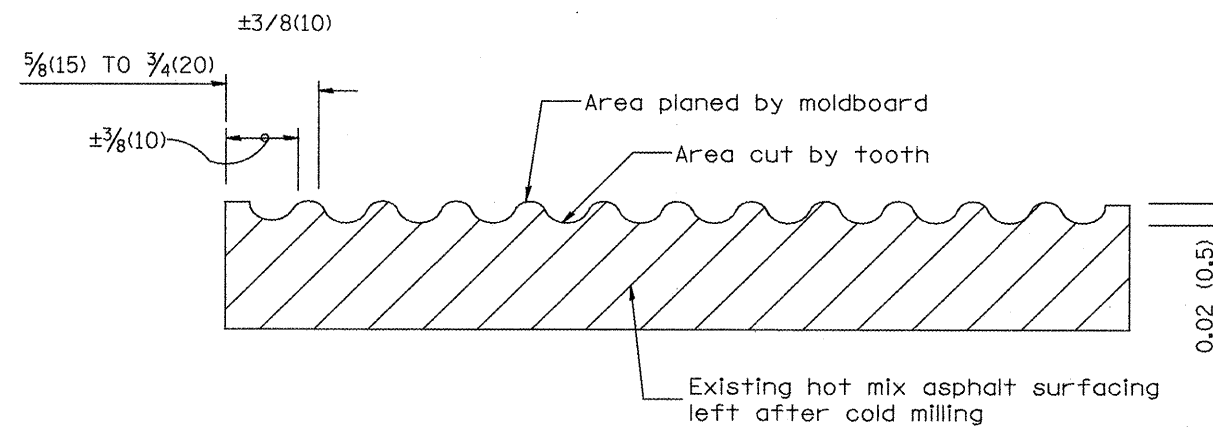

SECTION B-B PROJECTED
PERPENDICULAR TO CENTERLINE

All dimensions are in Inches (millimeters) unless otherwise noted.

•• 101RS-3; 102RS-4; 103RS-4; 104RS-7

01-01-97	RENUM. C-104.01, NEW REVISION BOX	T.P.
04-20-98	REMOVED MILLING DETAIL FROM STANDARD	J.A.
09-08-98	CORRECT NOTE LEADER PLACEMENT	R.W.
10-16-06	REVISED TO 2007 SPEC.	M.A.

STATE OF ILLINOIS
DEPARTMENT OF TRANSPORTATION

HOT MIX ASPHALT SURFACE REMOVAL (COLD MILLING)

NOT TO SCALE

CADD STD. 440001-D4

F.A.P. RTE.	SECTION	COUNTY	TOTAL SHEETS	SHEET NO.
673	**	TAZE/WOOD	60	51
FED. ROAD DIST. NO.			ILLINOIS FED. AID PROJECT	
			CONTRACT NO. 68920	

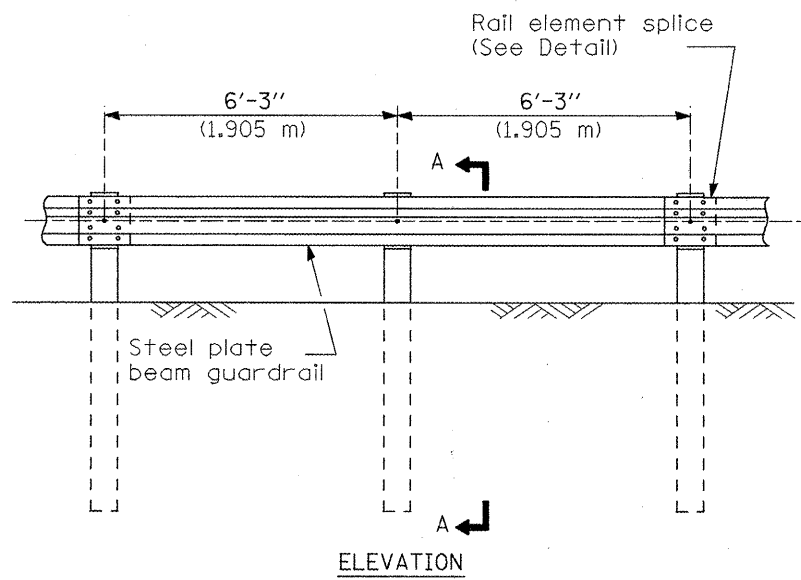

TYPE A

6'-3" (1.905 m) Typical post spacing

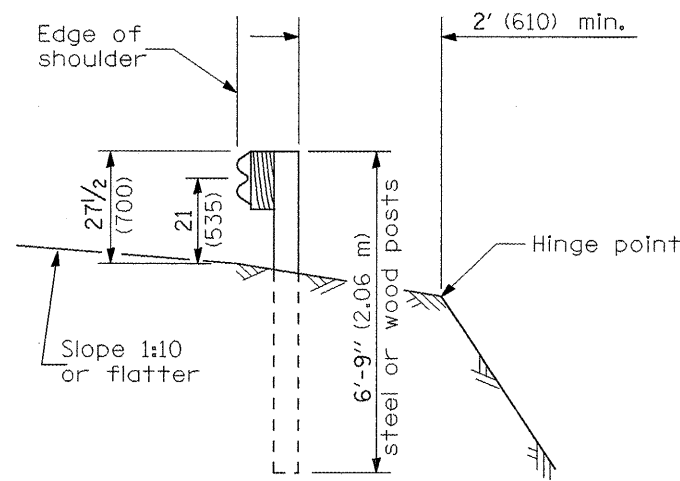

SECTION A-A

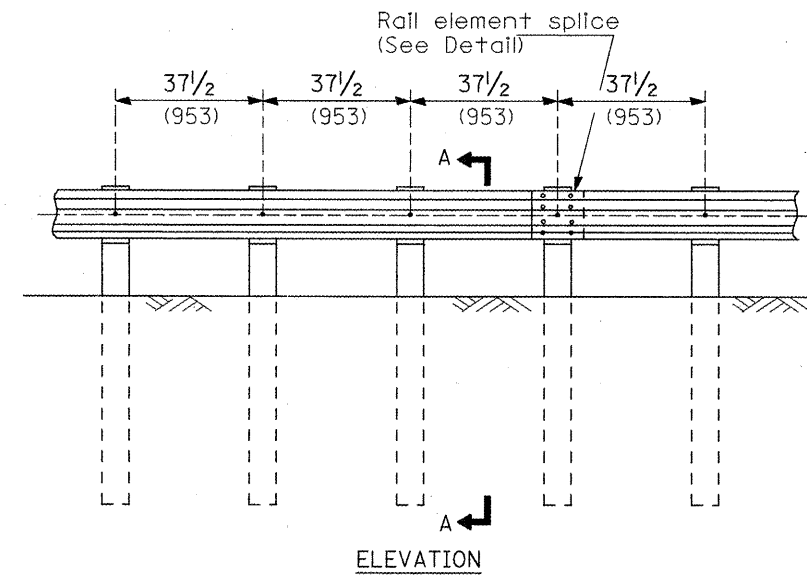

TYPE B

37 1/2 (953) Closed post spacing

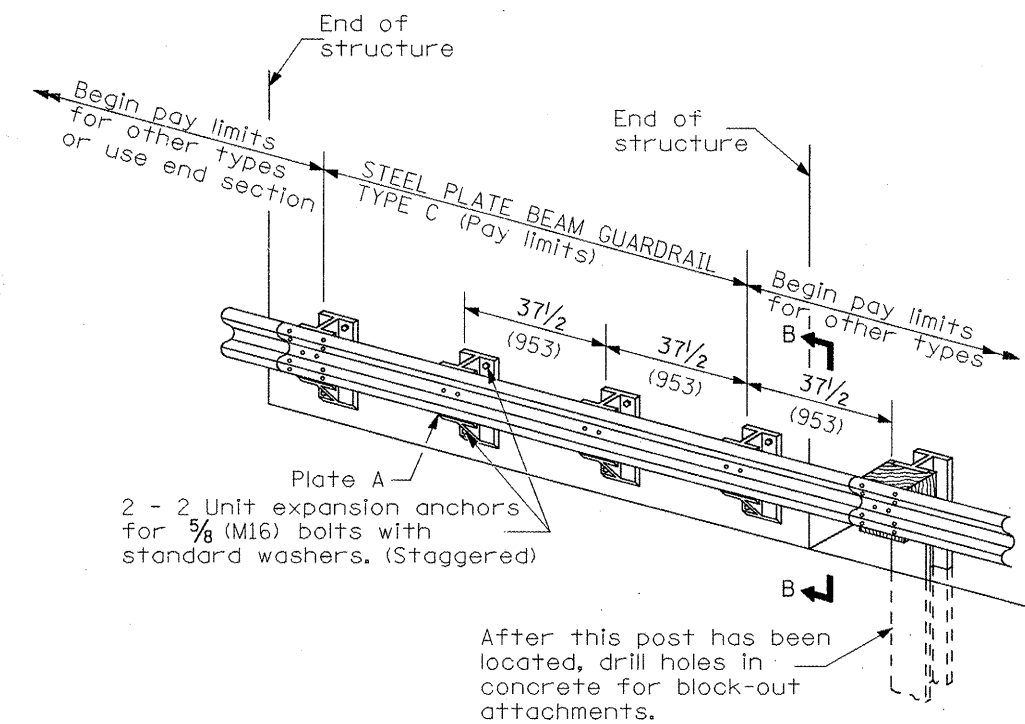

TYPE C

37 1/2 (953) Block-out spacing

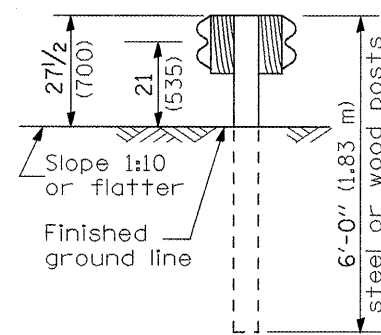

SECTION C-C

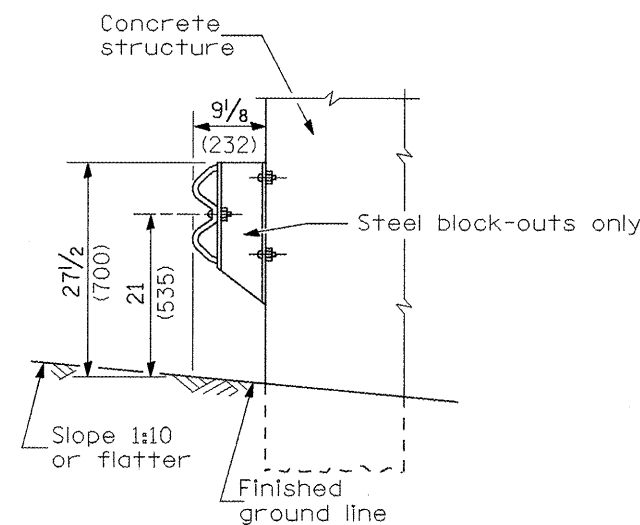

SECTION B-B

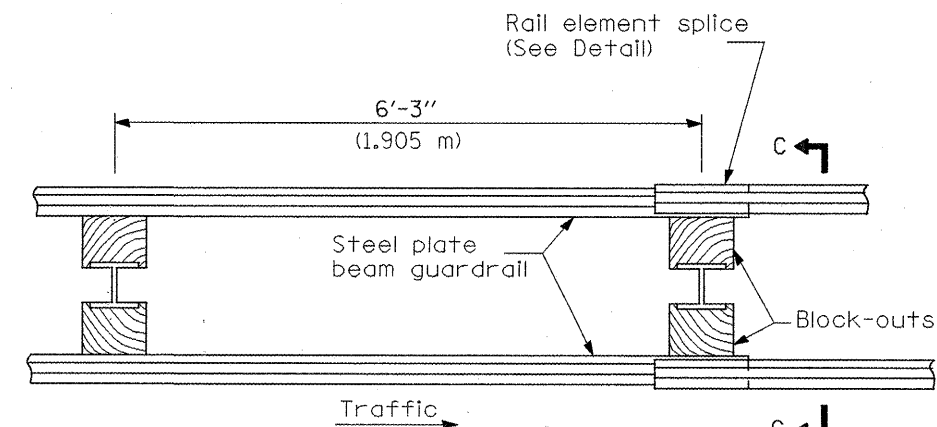

PLAN

TYPE D

Double steel plate beam guardrail
6'-3" (1.905 m) typical post spacing

GENERAL NOTES

All slope ratios are expressed as units of vertical displacement to units of horizontal displacement (V:H).

All dimensions are in millimeters (inches) unless otherwise shown.

The existing steel posts may be drilled to match the bolt pattern shown herein for the wood block-out, or a new steel post shall be provided.

This detail is applicable to the guardrail system used prior to January 1, 2007. For details on the Midwest Guardrail System, see Standard 630001.

All dimensions are in inches (millimeters) unless otherwise noted.

03-01-07	NEW DETAIL	RJD			
----------	------------	-----	--	--	--

**STATE OF ILLINOIS
DEPARTMENT OF TRANSPORTATION**

REMOVE AND REERECT STEEL PLATE BEAM GUARDRAIL
SHT. 1 OF 4
CADD STD. 630011-D4
NOT TO SCALE

F.A.P. RTE.	SECTION	COUNTY	TOTAL SHEETS	SHEET NO.
673	**	TAZE/WOOD	60	52
FED. ROAD DIST. NO.			CONTRACT NO. 68920	

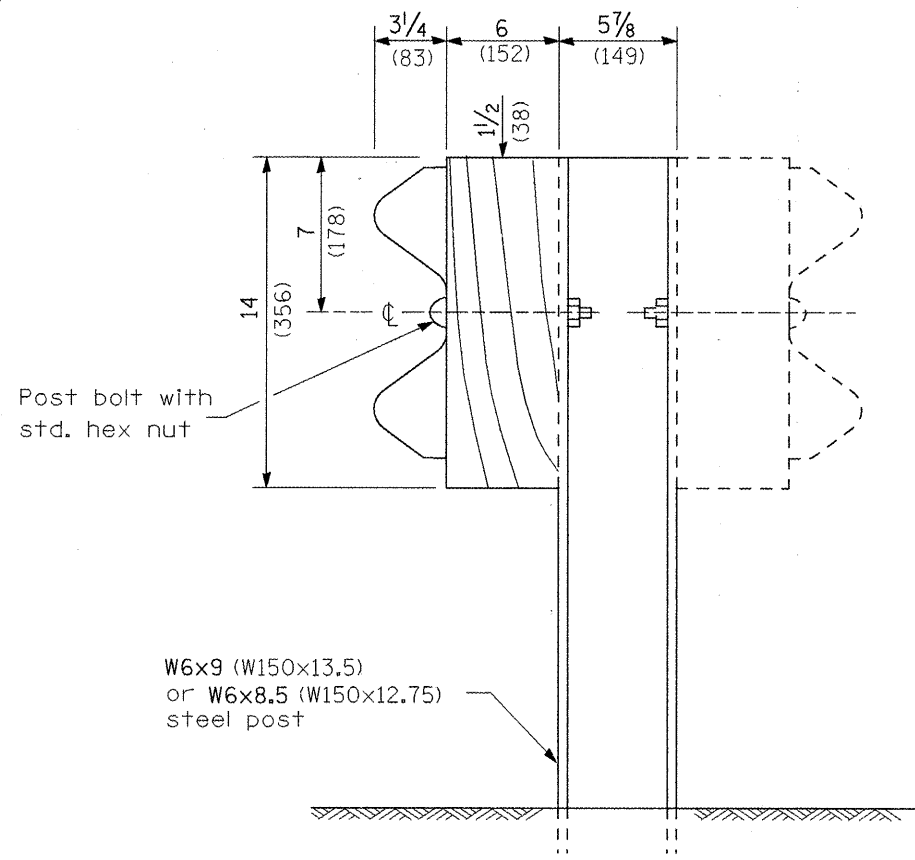

STEEL POST CONSTRUCTION

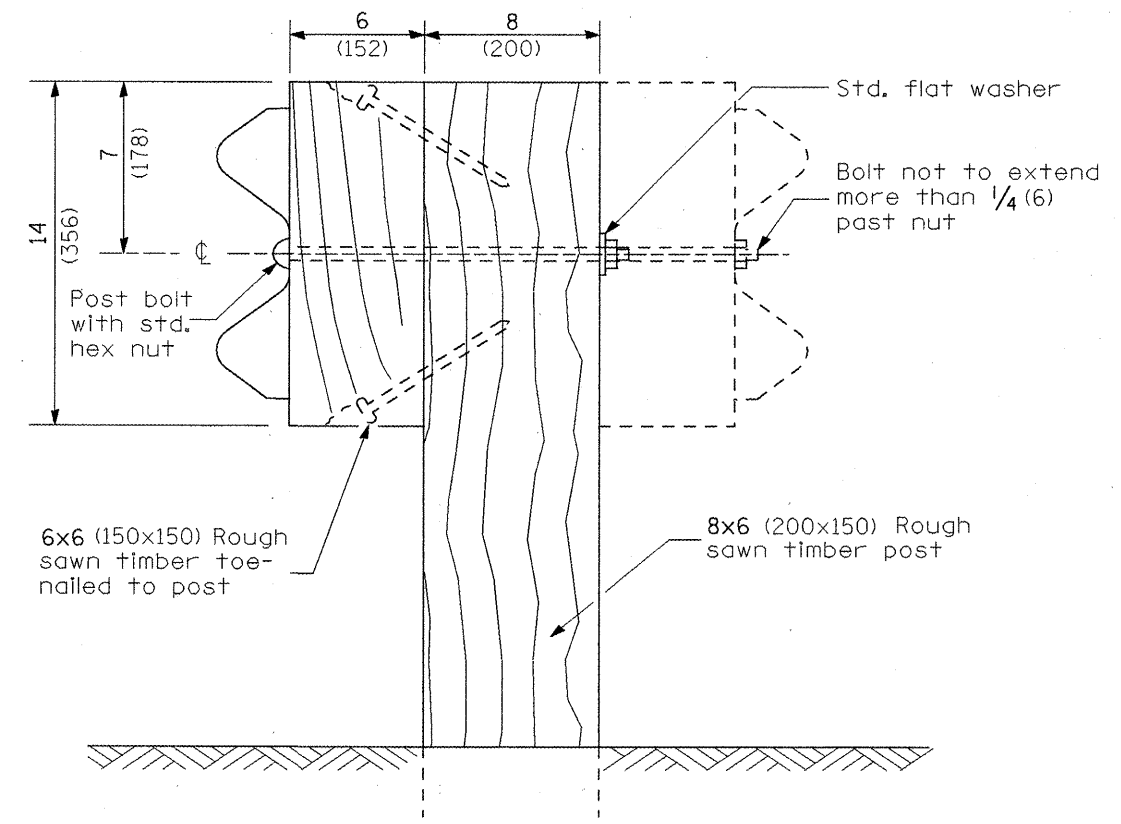

WOOD POST CONSTRUCTION

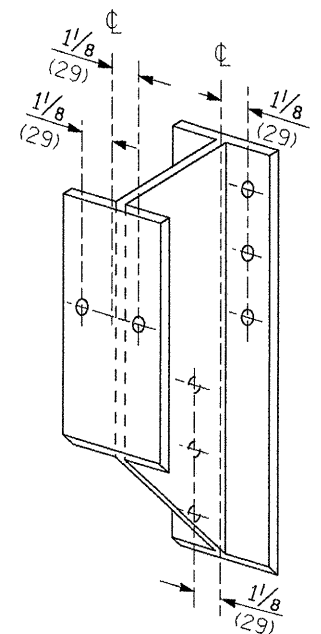

STEEL BLOCK-OUT DETAIL

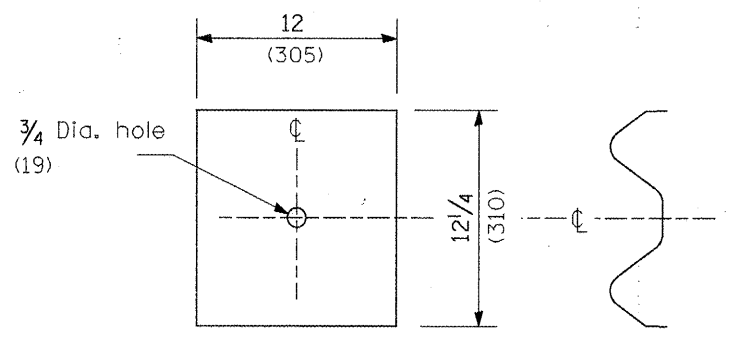
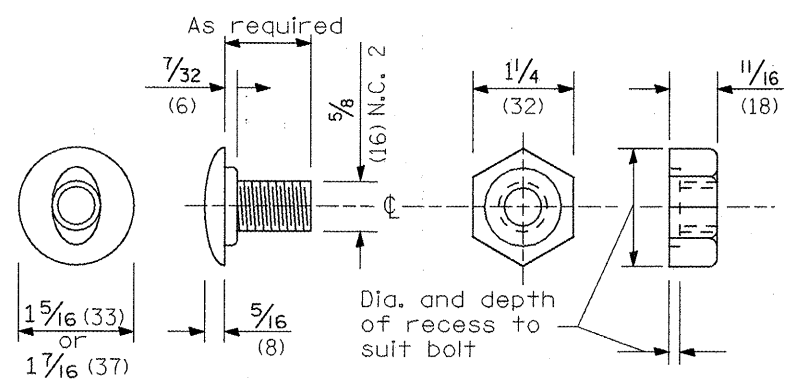

PLATE A

NOTE
Plate A shall be placed between rail element and block-out at non-splice mounting points only when steel block-outs are used.



POST OR SPLICE BOLT & NUT

All dimensions are in inches (millimeters) unless otherwise noted.

STATE OF ILLINOIS
DEPARTMENT OF TRANSPORTATION

REMOVE AND REERECT STEEL PLATE BEAM GUARDRAIL

NOT TO SCALE

SHT. 2 OF 4
CADD STD. 630011-D4

F.A.P. RTE.	SECTION	COUNTY	TOTAL SHEETS	SHEET NO.
673	..	TAZE/WOOD	66	53
FED. ROAD DIST. NO. ILLINOIS FED. AID PROJECT			CONTRACT NO. 68920	

Place standard end shoe between splice plate and rail element

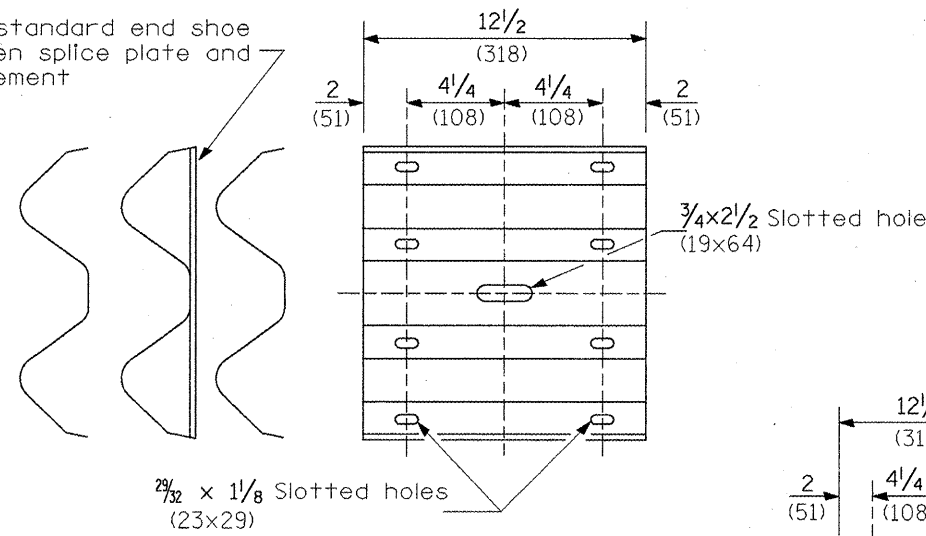

SPLICE PLATE

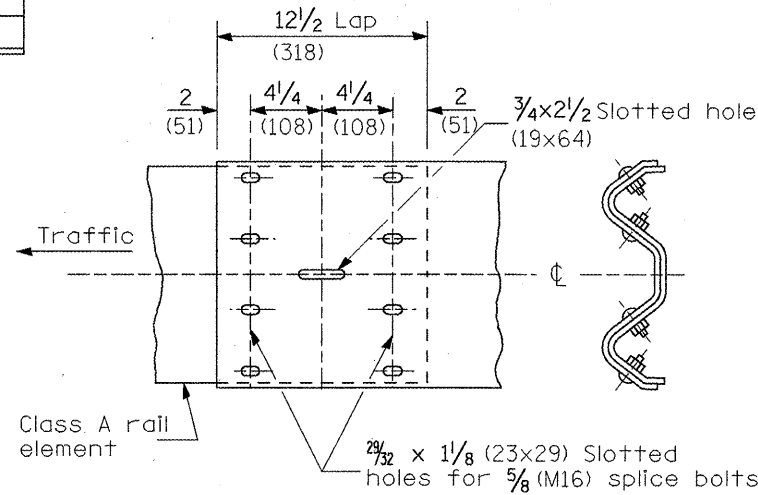

RAIL ELEMENT SPLICE

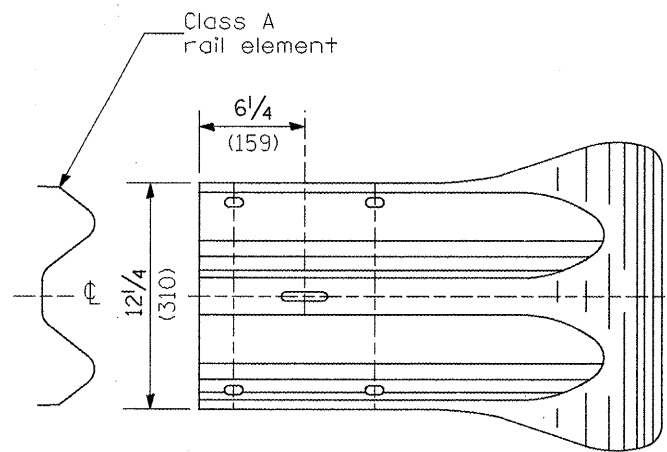
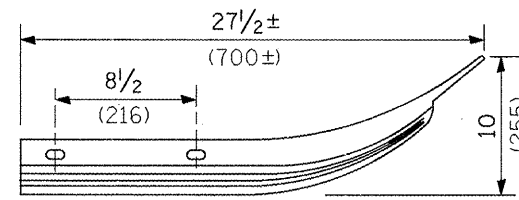

END SECTION

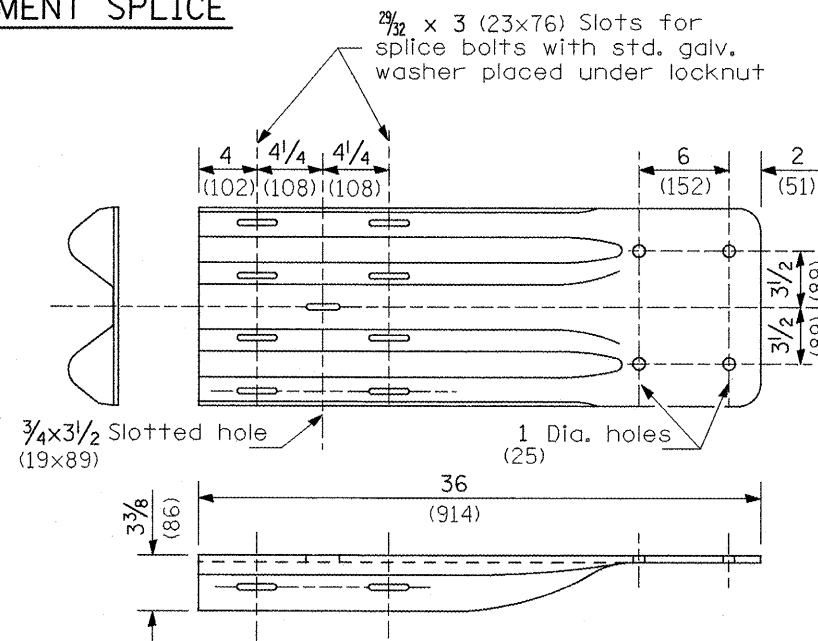

NOTE

When end shoe is attached to a bridge parapet which has an expansion joint, the bolts shall be provided with a locknut or double nut and shall be tightened only to a point that will allow guardrail movement.

The standard end shoe shall be attached to the concrete with pre-drilled or self-drilling anchor bolts. The anchor cone shall be set flush with the surface of the concrete.

Externally threaded studs protruding from the surface of the concrete will not be permitted.

END SHOE

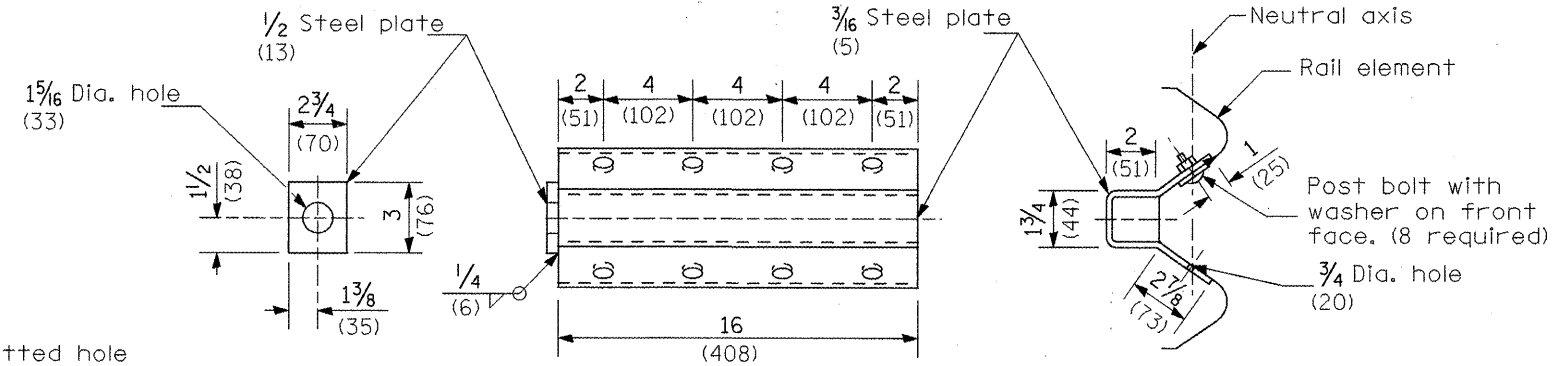

NOTE

Anchor plate T shall be used to attach cable assembly to guardrail when required on traffic barrier terminals.

ANCHOR PLATE T DETAILS

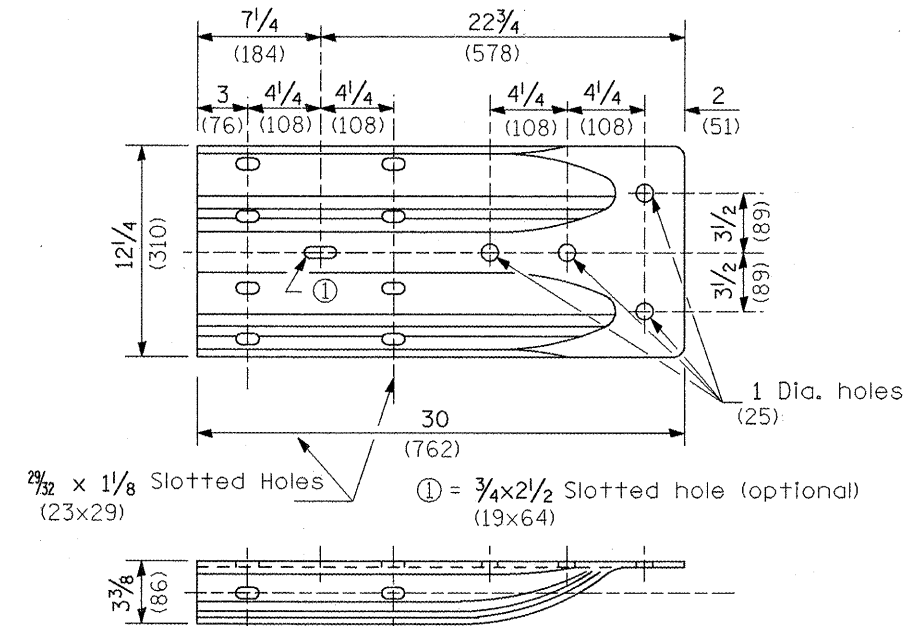

ALTERNATE END SHOE

All dimensions are in inches (millimeters) unless otherwise noted.

F.A.P. RTE.	SECTION	COUNTY	TOTAL SHEETS	SHEET NO.
673	**	TAZE/WOOD	60	54
CONTRACT NO. 68920			FED. ROAD DIST. NO. ILLINOIS FED. AID PROJECT	

STATE OF ILLINOIS
DEPARTMENT OF TRANSPORTATION

REMOVE AND REERECT STEEL PLATE BEAM GUARDRAIL

NOT TO SCALE

SHT. 3 OF 4
CADD STD. 630011-D4

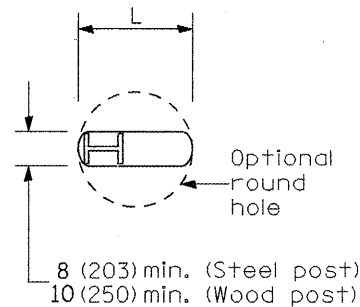

PLAN

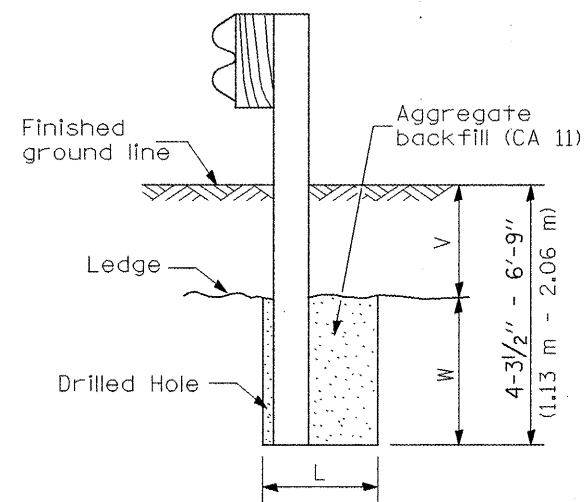

Notes:
Ledge line is top of rock ledge or hard slag fill.

ELEVATION

FOOTING FOR POST WHEN IMPERVIOUS MATERIAL IS ENCOUNTERED

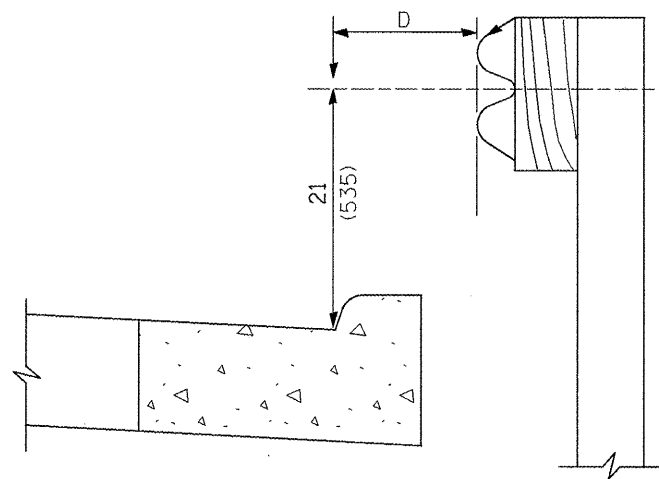

Note:
If it is necessary for D to be more than 12 (300) and less than 10'-0" (3.0 m) type M-2 (M-5) curb and gutter (Std. 606001) shall be used in front of and in advance of the guardrail.

GUARDRAIL PLACED BEHIND CURB

(D = 0 desirable to 12 (300) maximum)

V	W	L	
		Steel Post	Wood Post
0 - 18 (0 - 460)	24 (610)	21 (530)	23 (580)
>18 - 41.5 (>460 - 825)	12 (305)	8 (203)	10 (250)
>41.5 - 53.5 (>825 - 1.13 m)	12 - 0 (305 - 0)	8 (203)	10 (250)

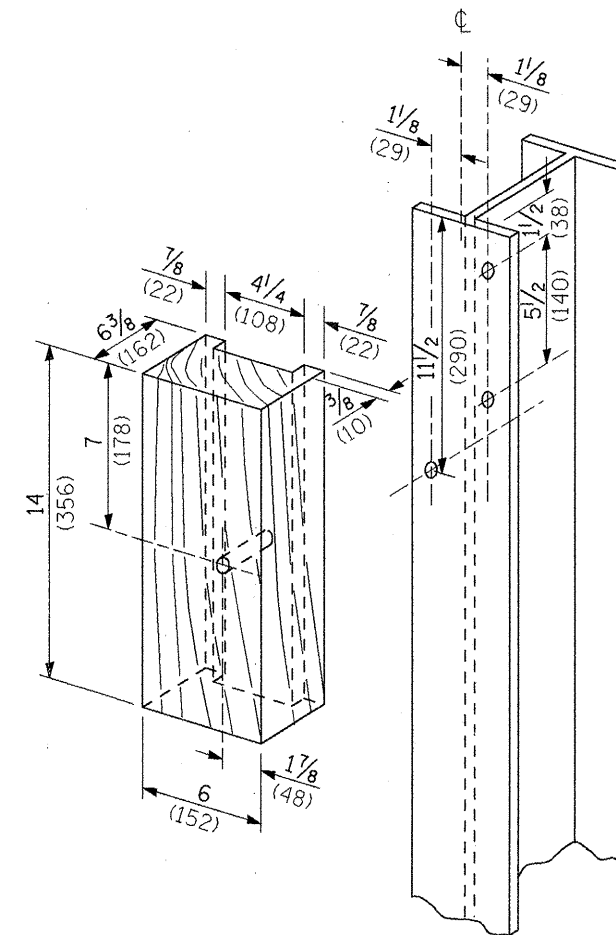

WOOD BLOCK-OUT AND STEEL POST DETAILS

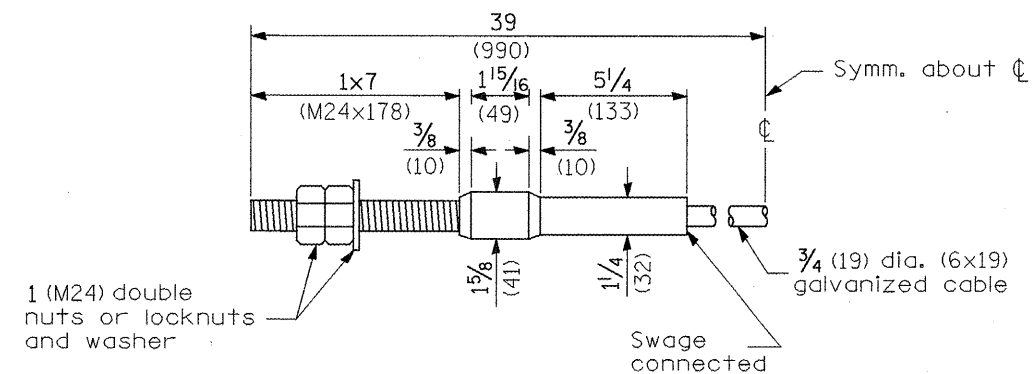

CABLE ASSEMBLY

(18,100 kg (40,000 lbs.) min. breaking strength)
Tighten to taut tension.

All dimensions are in inches (millimeters) unless otherwise noted.

•• 101RS-3; 102RS-4; 103RS-4; 104RS-7

STATE OF ILLINOIS
DEPARTMENT OF TRANSPORTATION

REMOVE AND REERECT STEEL PLATE BEAM GUARDRAIL

NOT TO SCALE

SHT. 4 OF 4
CADD STD. 630011-D4

F.A.P. RTE.	SECTION	COUNTY	TOTAL SHEETS	SHEET NO.
673	••	TAZE/WOOD	60	55
CONTRACT NO. 68920			FED. ROAD DIST. NO. ILLINOIS FED. AID PROJECT	

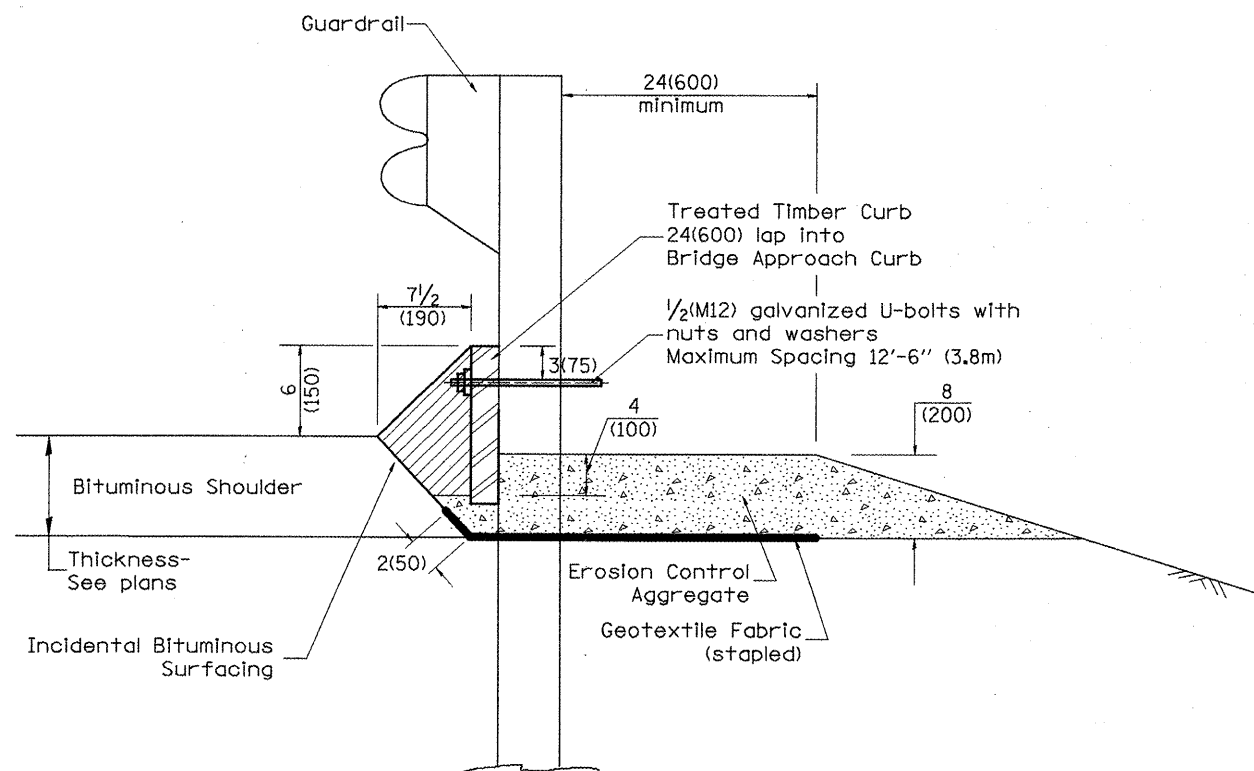

TYPICAL SECTION WITH EROSION CONTROL CURB

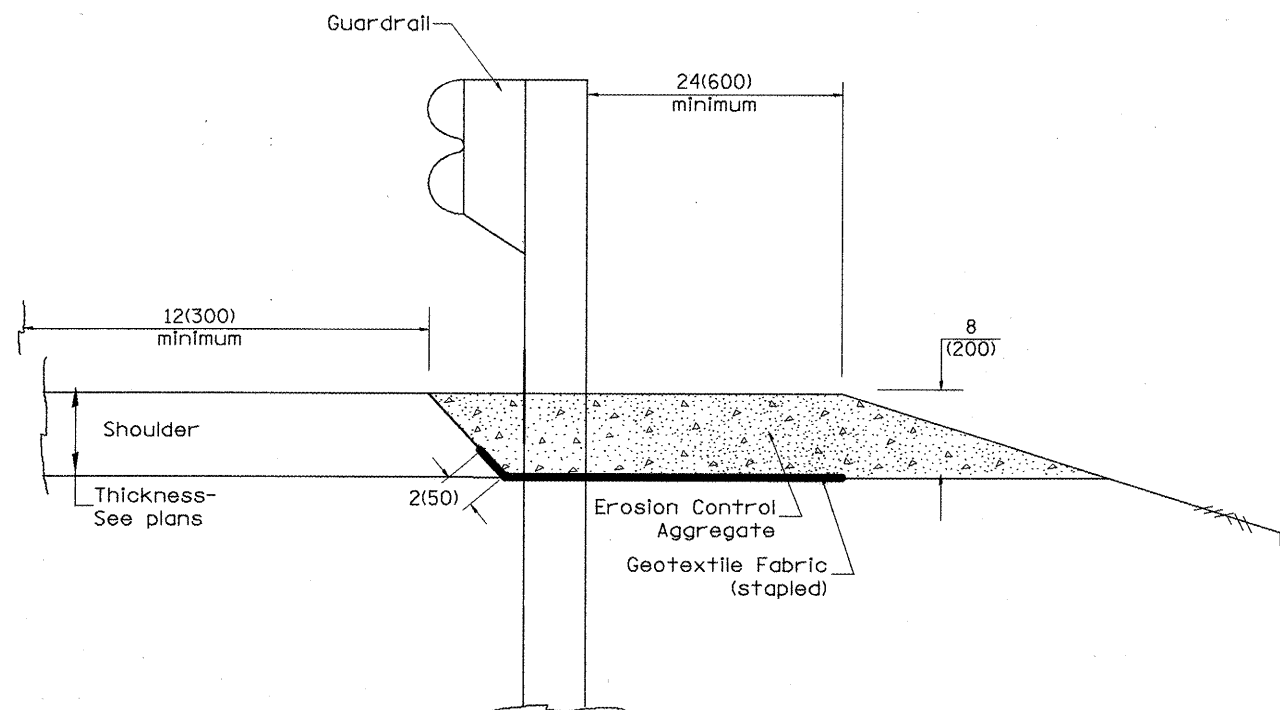

TYPICAL SECTION WITHOUT EROSION CONTROL CURB

GENERAL NOTES: EROSION CONTROL CURB

1. This work shall consist of grading as needed, installing hardware and treated timber boards, furnishing and placing mastic material and incidental bituminous surfacing in front of Steel Plate Beam Guardrail in accordance with Plan Details.
2. Timber shall be treated in accordance with Article 1007.12. All preservatives specified in the article will be allowed. Waterborne preservatives "asa" and "cca" shall have a minimum retention of 0.40 lbs./cu. ft. (6.4 kg/m³)

GENERAL NOTES: GUARDRAIL AGGREGATE EROSION CONTROL

1. This work shall consist of grading as needed, furnishing and installing geotextile fabric and staples, and furnishing, placing and shaping crushed aggregate around and behind Steel Plate Beam Guardrail posts in accordance with Plan Details.
2. Before placing the aggregate and the Geotextile Fabric, weeds and grass shall be removed from the area to be covered.
3. After the area has been prepared, and in a dry condition, the Geotextile fabric shall be placed with a 12(300) minimum overlap. A knife cut for guardrail post installation is necessary.
4. The aggregate shall be deposited, compacted and shaped by either mechanical or hand methods, in a manner reasonably true to line and grade.
5. The Contractor shall have the option of placing the guardrail before or after the Geotextile Fabric and Aggregate are in place. If the guardrail is placed after the Geotextile Fabric and Aggregate, then any voids must be filled and the aggregate returned to line and grade.
6. Materials shall meet the following requirements:
 - A. The crushed aggregate shall be CA1 gradation in accordance with Article 1004.01(c) of the Standard Specifications.
 - B. The Geotextile Fabric shall be nonwoven fabric in accordance with Article 1080.02 of the Standard Specifications.

All dimensions are in Inches (millimeters) unless otherwise noted.

01-01-97	RENUM. C-22.01, NEW REVISION BOX	T.P.
03-01-97	CORRECT STD. NUMBERS IN NOTES PG. 2	J.A.
11-03-00	CORRECTION TO NOTES	M.A.
10-16-06	REVISED TO 2007 SPEC.	M.A.

**STATE OF ILLINOIS
DEPARTMENT OF TRANSPORTATION**

GUARDRAIL EROSION CONTROL TREATMENTS

NOT TO SCALE

SHT. 1 OF 2
CADD STD. 630101-D4

F.A.P. RTE.	SECTION	COUNTY	TOTAL SHEETS	SHEET NO.
673	**	TAZE/WOOD	60	56
FED. ROAD DIST. NO.			CONTRACT NO. 68920	
ILLINOIS			FED. AID PROJECT	

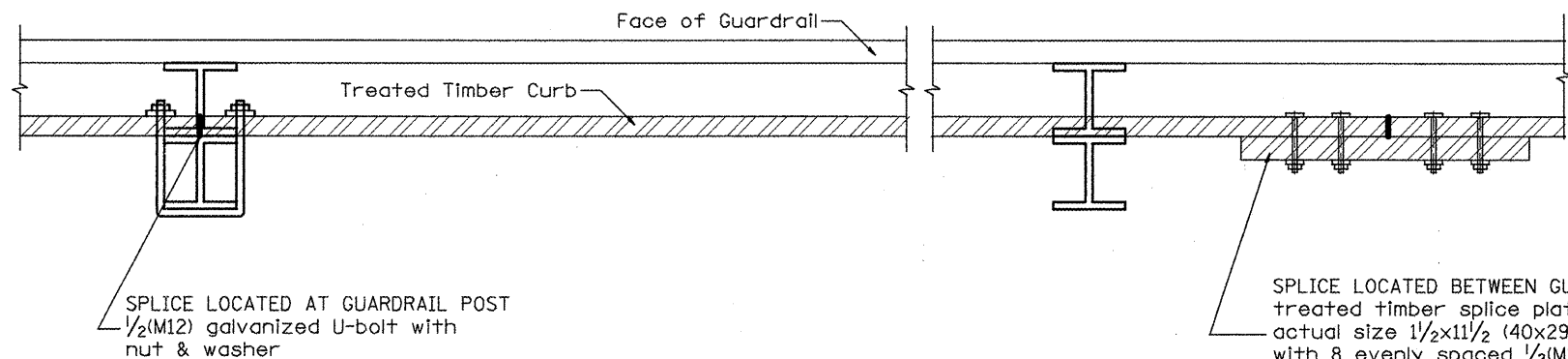

DETAIL A
(Typical Treated Timber Splices)

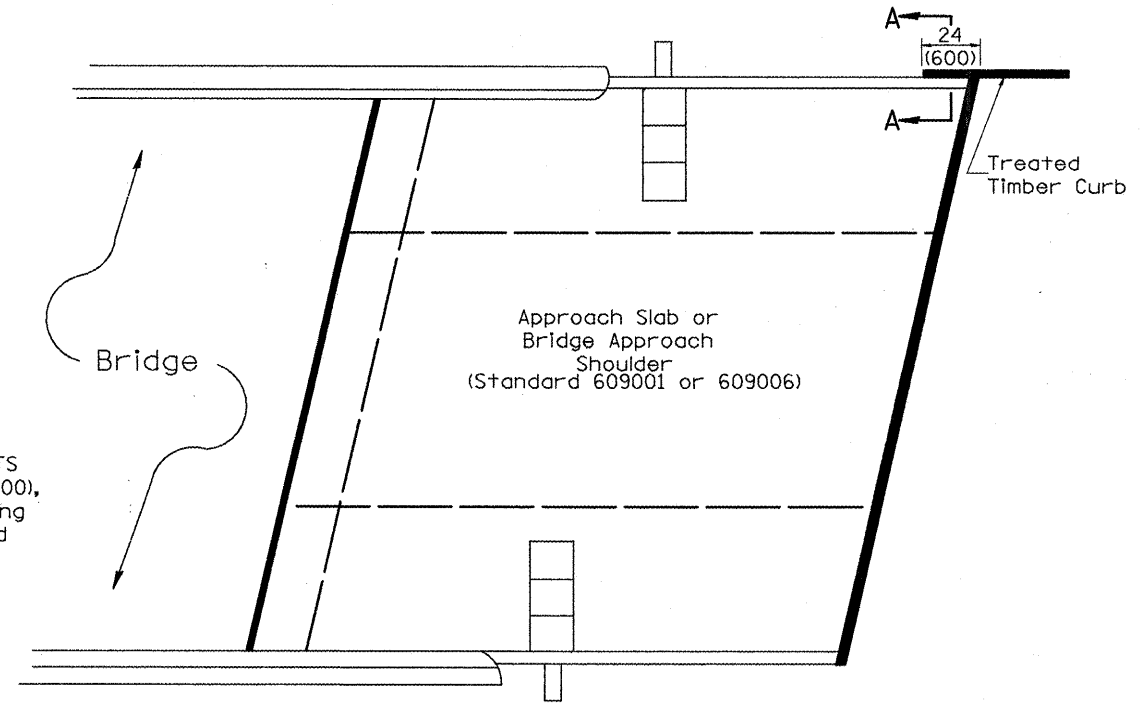

PLAN VIEW
APPROACH SLAB OR BRIDGE APPROACH SHOULDER
(STANDARD 609001 or 609006)

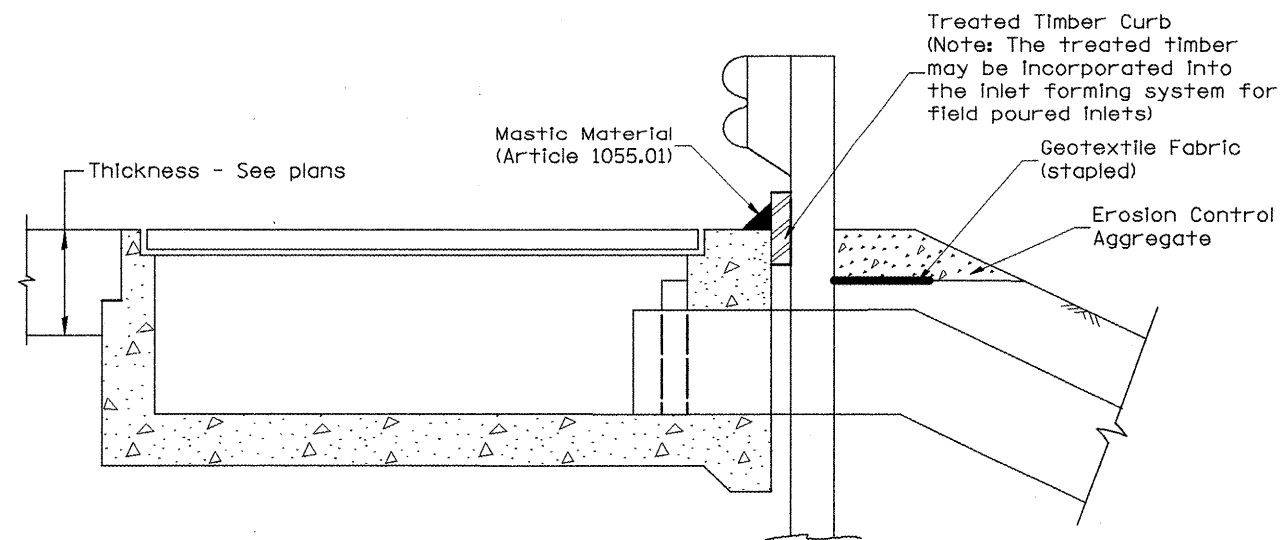

TYPICAL SECTION WITH EROSION CONTROL CURB
AT INLETS TYPE E & F (STANDARD 610001)

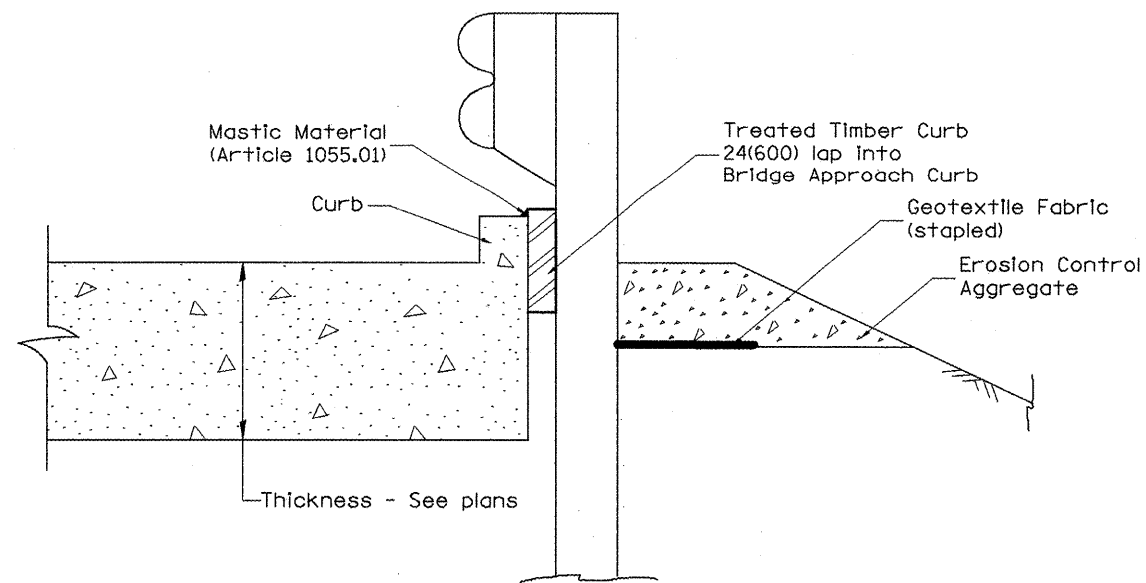

SECTION A-A
TYPICAL SECTION WITH EROSION CONTROL CURB
AT BRIDGE APPROACH CURB
(STANDARD 609001 OR 609006)

All dimensions are in inches (millimeters) unless otherwise noted.

101RS-3; 102RS-4; 103RS-4; 104RS-7

STATE OF ILLINOIS
DEPARTMENT OF TRANSPORTATION

GUARDRAIL EROSION CONTROL TREATMENTS

NOT TO SCALE

SHT. 2 OF 2
CADD STD. 630101-D4

F.A.P. RTE.	SECTION	COUNTY	TOTAL SHEETS	SHEET NO.
673	**	TAZE/WOOD	60	57
FED. ROAD DIST. NO.			ILLINOIS FED. AID PROJECT	
			CONTRACT NO. 68920	

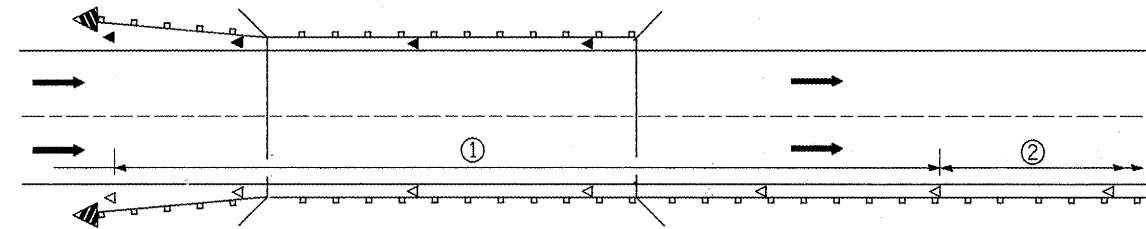

① Spacing 80 ft. (24 m) max. for first 400 ft. (122 m) or curve spacing shown in Standard 635001, whichever is less (min. 4 reflectors regardless of length).

② After 400 ft. (122 m), transition to normal delineator spacing shown in Standard 635001, and continue as required.

ONE-WAY TRAFFIC

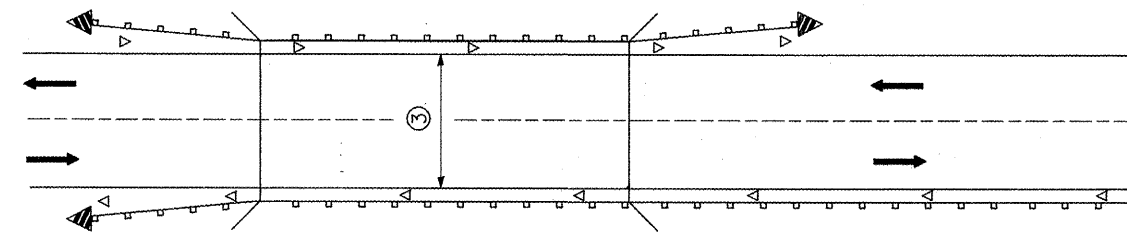

③ Bidirectional silver/silver should be used in lieu of monodirectional silver on both sides of two-lane bridges where the bridge pavement is less than 24 (6.1) wider than the pavement approaching the bridge.

TWO-WAY TRAFFIC

GUARDRAIL / BARRIER WALL / BRIDGE RAIL REFLECTORS

LEGEND

- ◁ Monodirectional silver
- ◄ Monodirectional amber
- ◄ Terminal Marker - Black/Yellow
Left or Right as appropriate

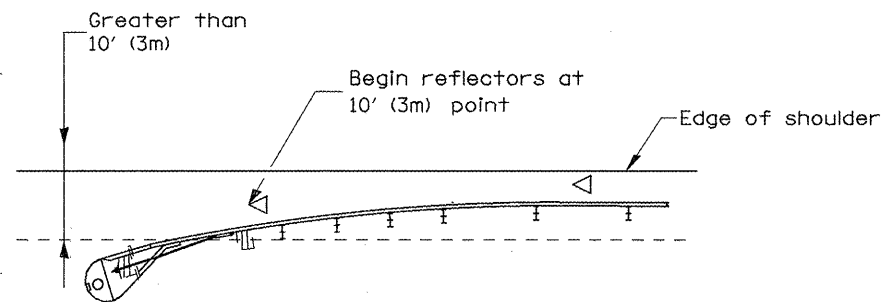

NOTE: Omit terminal marker when terminal over 10' (3m) from edge of paved shoulder or break point of unpaved shoulder, or when terminal buried in backslope.

Traffic Barrier Terminal Type(*) and/or Turned-Down Terminal

[Terminal over 10' (3m) from edge of shoulder]
*See Plans for Type

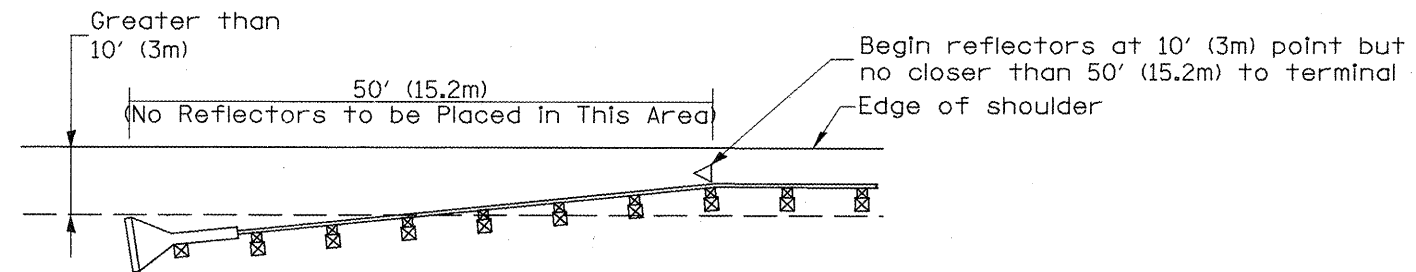

NOTE: Omit terminal marker when terminal over (10') from edge of paved shoulder or break point of unpaved shoulder.

Traffic Barrier Terminal Type 1 (Special)
[Terminal over 10' (3m) from edge of shoulder]

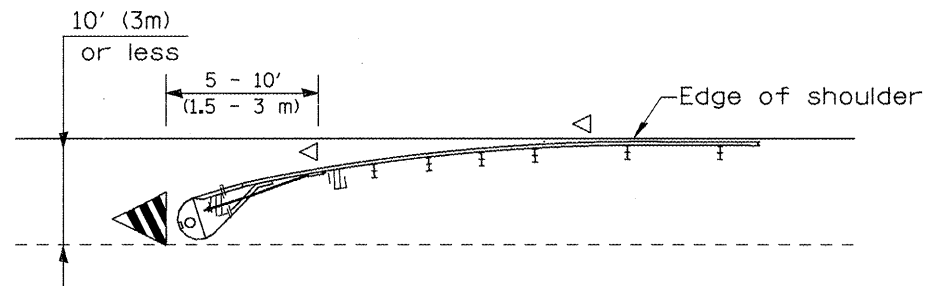

Traffic Barrier Terminal Type(*) and/or Turned-Down Terminal
[Terminal over 10' (3m) or less from edge of shoulder]
*See Plans for Type

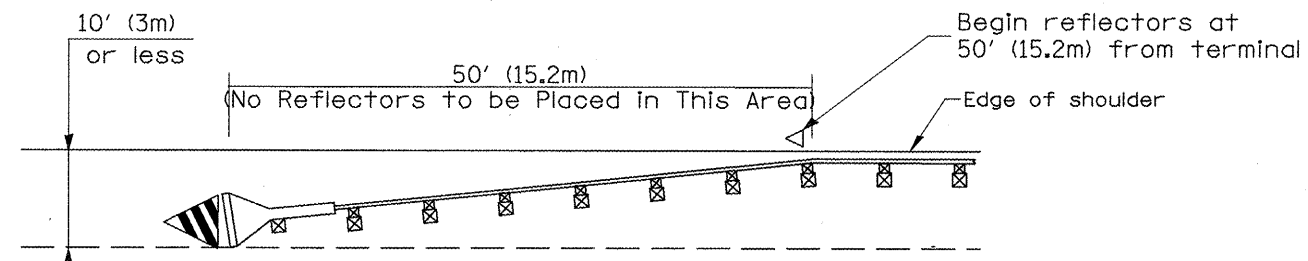

Traffic Barrier Terminal Type 1(Special)
[Terminal 10' (3m) or less from edge of shoulder]

TERMINAL MARKER PLACEMENT

All dimensions are in inches (millimeters) unless otherwise noted.

01-01-97	RENUM. E-10.02, NEW REVISION BOX	T.P.
03-01-97	CORRECT STD. SPEC. *	J.A.
10-16-06	REVISED TO 2007 SPEC.	M.A.

**STATE OF ILLINOIS
DEPARTMENT OF TRANSPORTATION**

GUARDRAIL AND BARRIER WALL DELINEATION

NOT TO SCALE

SHT. 1 OF 3
CADD STD. 635101-D4

F.A.P. RTE.	SECTION	COUNTY	TOTAL SHEETS	SHEET NO.
673	**	TAZEWOOD	60	58
FED. ROAD DIST. NO. ILLINOIS FED. AID PROJECT			CONTRACT NO. 68920	

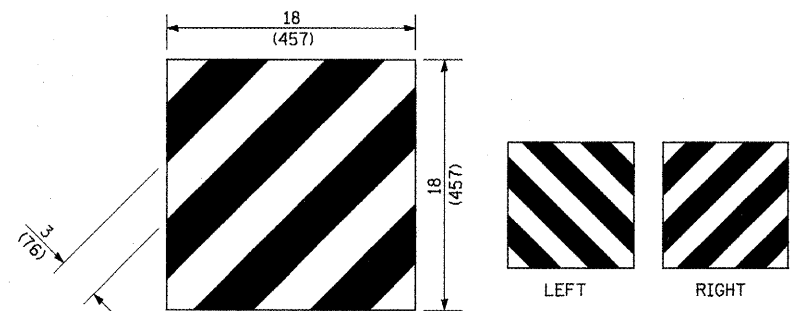

For Traffic Barrier Terminal Type 1 (Special)

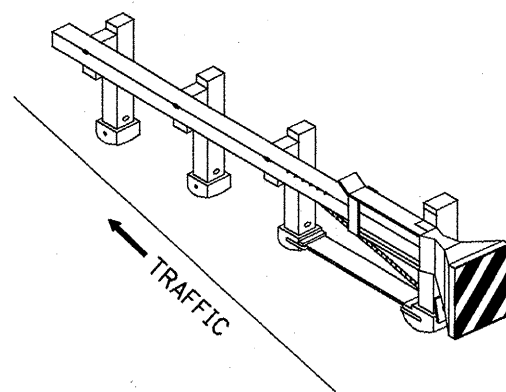

Standard Treatment - Direct Applied Sheeting
Traffic Barrier Terminal Type 1 (Special)

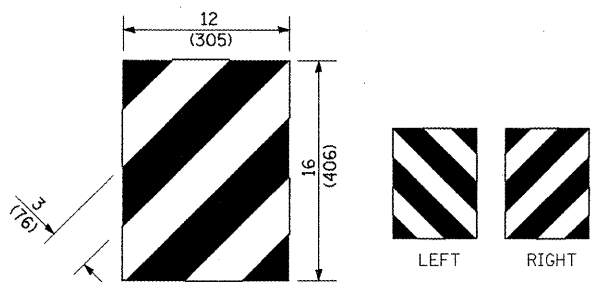

For Traffic Barrier Terminal Type (*)
and Post Mount
* See Plans for Type

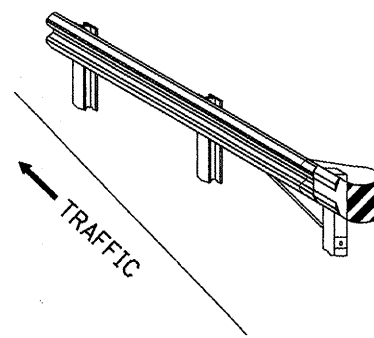

Standard Treatment - Direct Applied Sheeting
Traffic Barrier Terminal Type (*)
* See Plans for Type

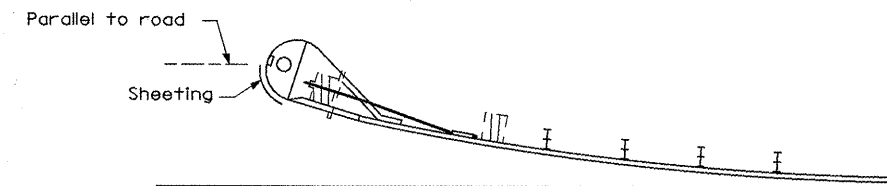

Sheeting Position for
Traffic Barrier Terminal Type (*)
* See Plans for Type

TERMINAL MARKER DETAILS

Color: Black / Yellow reflectorized
OM - I100 (L or R) Direct applied reflective sheeting
OM - I200 (L or R) Post mounted

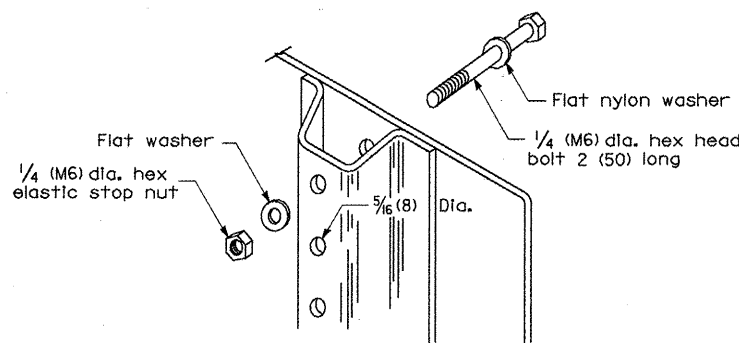

DETAIL OF MOUNTING TERMINAL MARKER TO POST

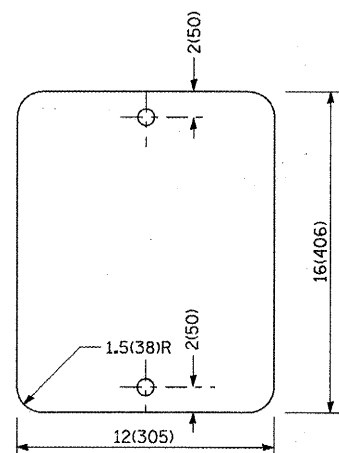

STANDARD TERMINAL MARKER

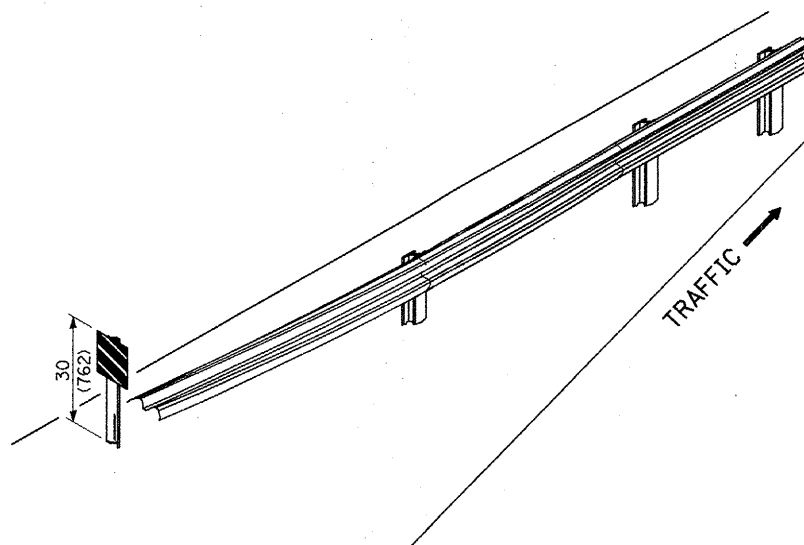

ALTERNATE TREATMENT - POST MOUNTED
(For turned-down terminal where sheeting cannot be direct applied)

TERMINAL MARKER TREATMENTS

GENERAL NOTES

All dimensions are in inches (millimeters) unless otherwise noted.

•• 101RS-3; 102RS-4; 103RS-4; 104RS-7

F.A.P. RTE.	SECTION	COUNTY	TOTAL SHEETS	SHEET NO.
673	..	TAZE/WOOD	60	59
FED. ROAD DIST. NO.			ILLINOIS FED. AID PROJECT	

STATE OF ILLINOIS
DEPARTMENT OF TRANSPORTATION

GUARDRAIL AND BARRIER WALL DELINEATION

NOT TO SCALE

SHT. 2 OF 3
CADD STD. 635101-D4

CONTRACT NO. 68920

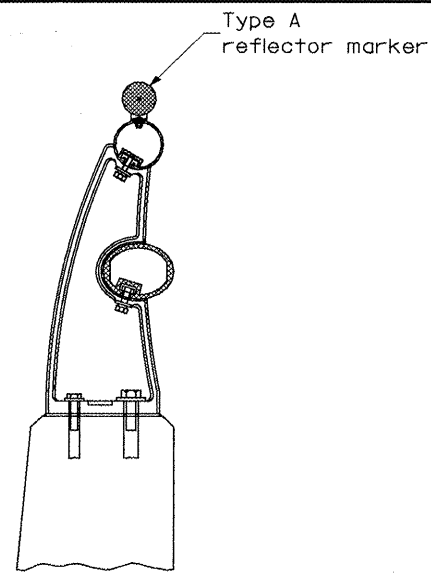

TYPICAL MOUNTING DETAIL FOR BRIDGE RAIL REFLECTOR

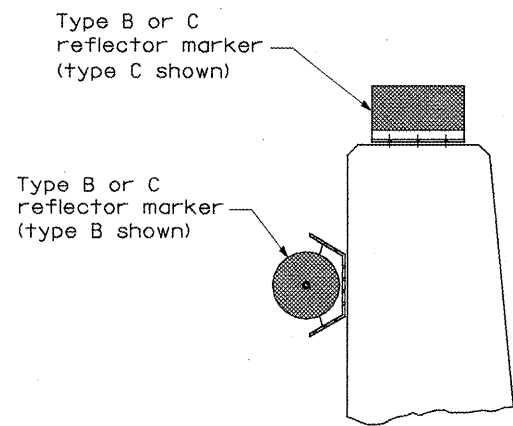

TYPICAL MOUNTING DETAIL FOR BARRIER WALL REFLECTOR

REFLECTOR MOUNTING

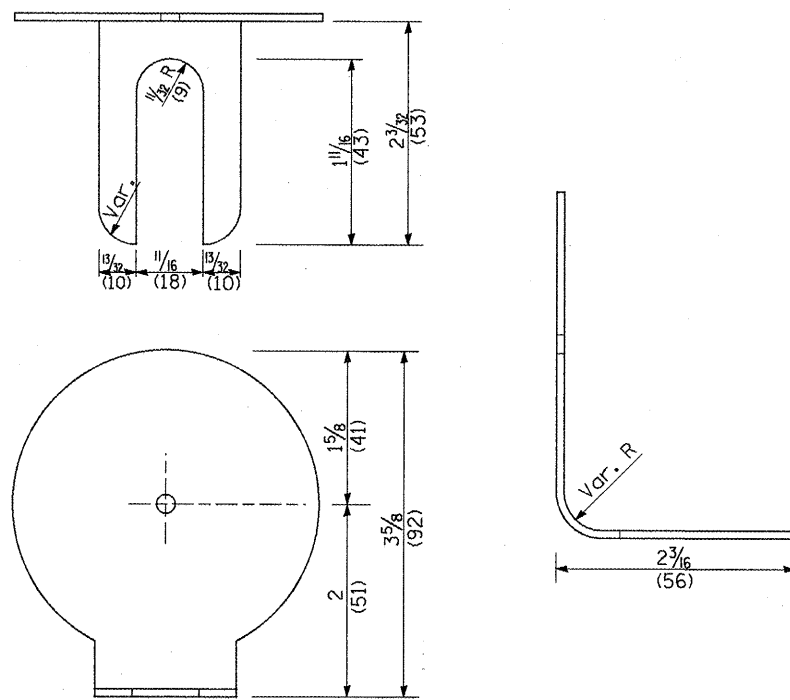

REFLECTOR MARKER TYPE A

Min. reflective area 6 1/2 sq. in. (4,194 mm²) each side. May be rectangular or slight trapezoid.

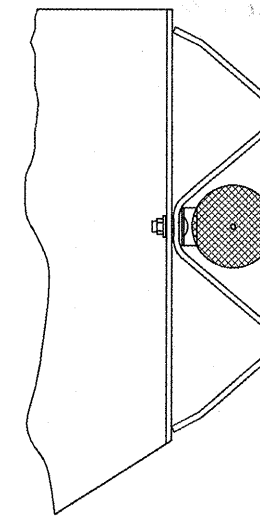

TYPICAL GUARDRAIL MOUNTING WITH REFLECTOR MARKER TYPE A

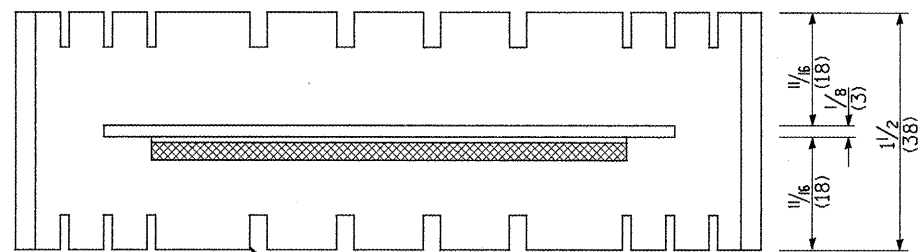

Adhesive weep slots or holes equally spaced on both sides

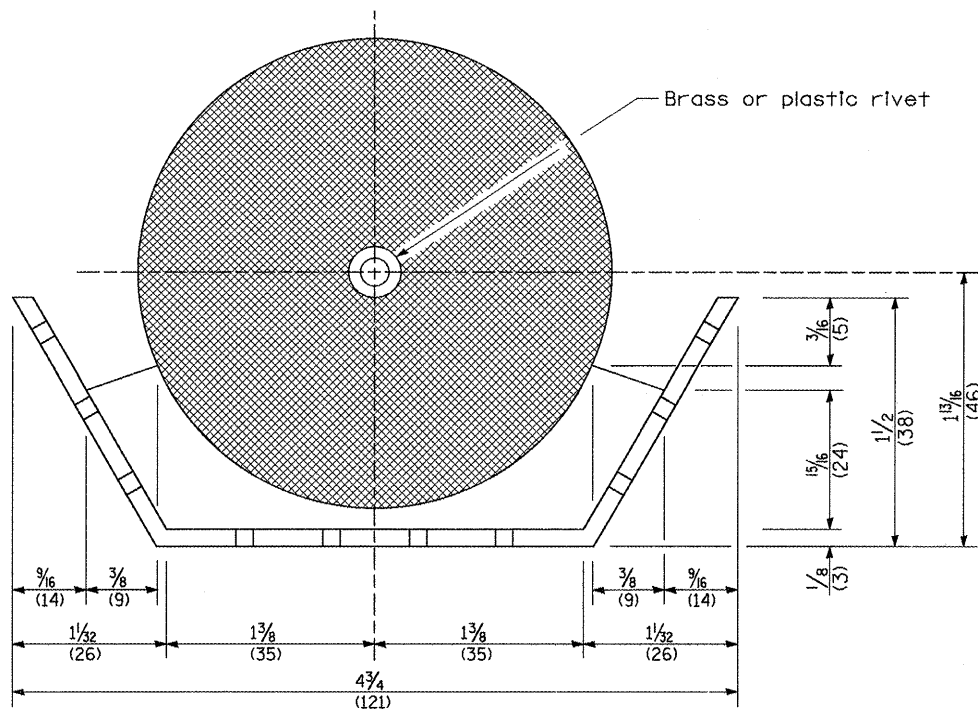

REFLECTOR MARKER TYPE B

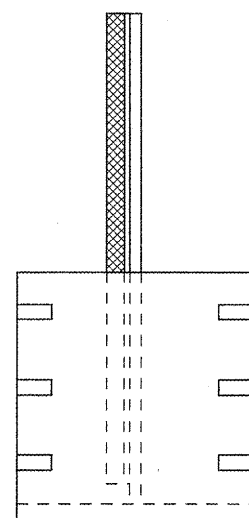

3 min. adhesive weep holes or slots each side, variable spacing.

REFLECTOR MARKER TYPE C

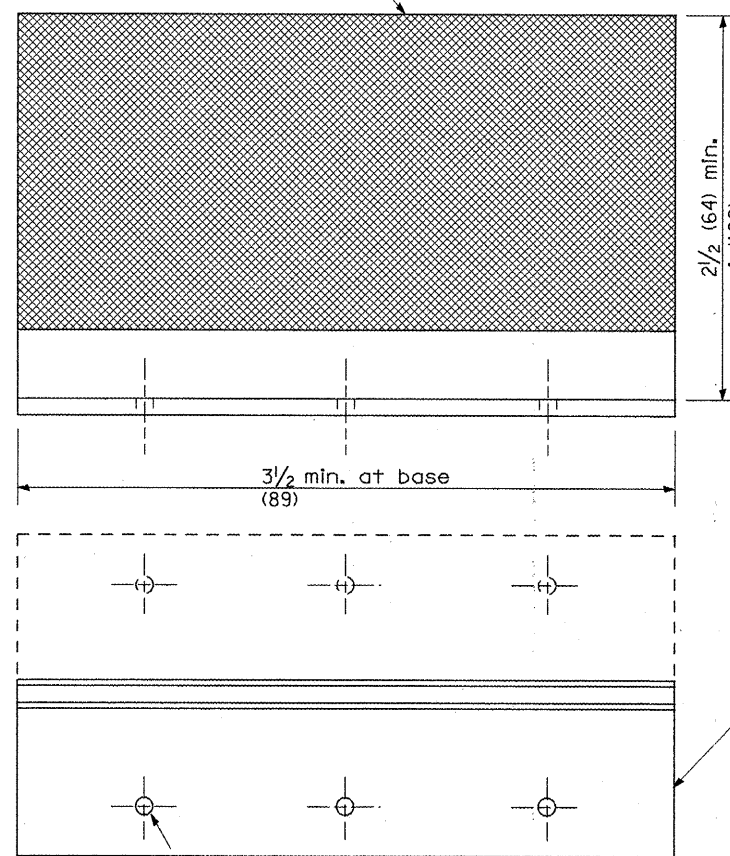

Minimum total area of base 7.0 Sq. in. (4,516 mm²)

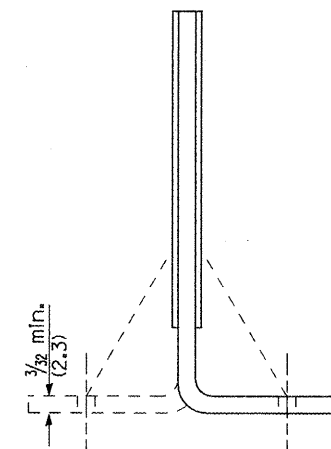

Cross section may be "T" or "L" shaped and may have side supports at ends.

REFLECTORS

All dimensions are in inches (millimeters) unless otherwise noted.

•• 101RS-3; 102RS-4; 103RS-4; 104RS-7

F.A.P. RTE.	SECTION	COUNTY	TOTAL SHEETS	SHEET NO.
673	**	TAZE/WOOD	60	60
FED. ROAD DIST. NO. ILLINOIS FED. AID PROJECT			CONTRACT NO. 68920	