

RAILROAD CROSSING WITH INTERCONNECT ONLY

RAILROAD CROSSING WITH INTERCONNECT AND PRE-SIGNALS

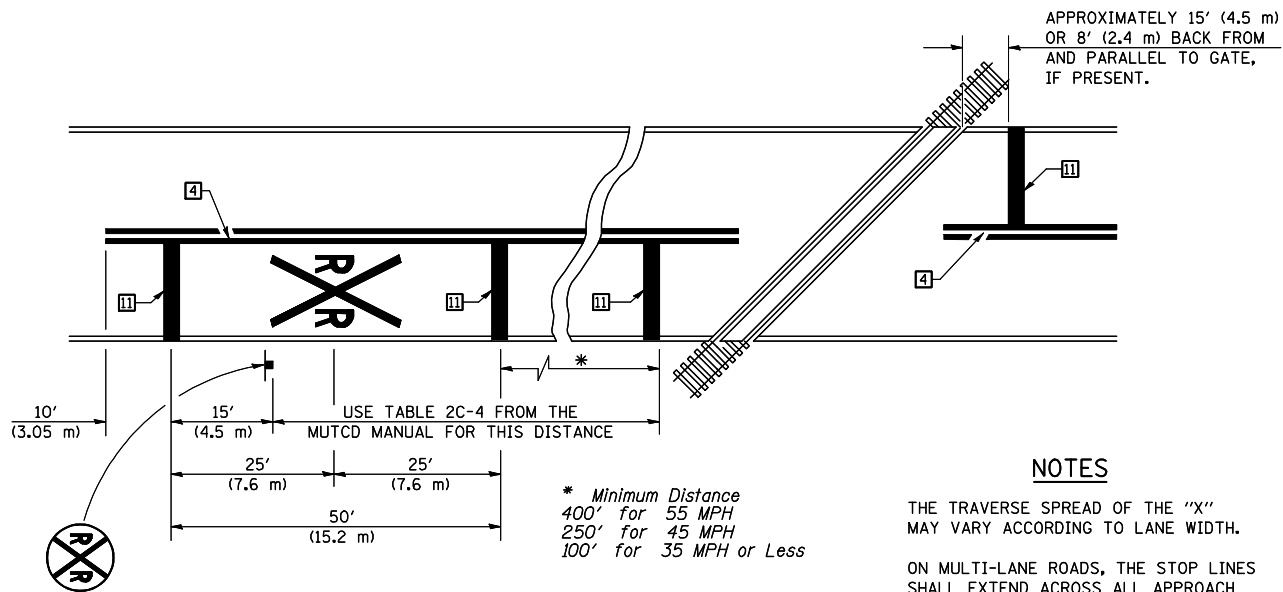

PAVEMENT MARKINGS AT RAILROAD-HIGHWAY GRADE CROSSING

NOTES

APPROXIMATELY 15' (4.5 m) OR 8' (2.4 m) BACK FROM AND PARALLEL TO GATE, IF PRESENT.

THE TRAVERSE SPREAD OF THE "X" MAY VARY ACCORDING TO LANE WIDTH.

ON MULTI-LANE ROADS, THE STOP LINES SHALL EXTEND ACROSS ALL APPROACH LANES AND SEPARATE RXR SYMBOLS SHALL BE PLACED ADJACENT TO EACH OTHER IN EACH LANE.

WHEN THE PAVEMENT MARKING SYMBOL IS USED, A PORTION OF THE SYMBOL SHOULD BE LOCATED DIRECTLY ADJACENT TO THE ADVANCE WARNING SIGN (W10-1) AS PLACED BY TABLE II-1, CONDITION B OF THE MUTCD.

* Minimum Distance
400' for 55 MPH
250' for 45 MPH
100' for 35 MPH or Less

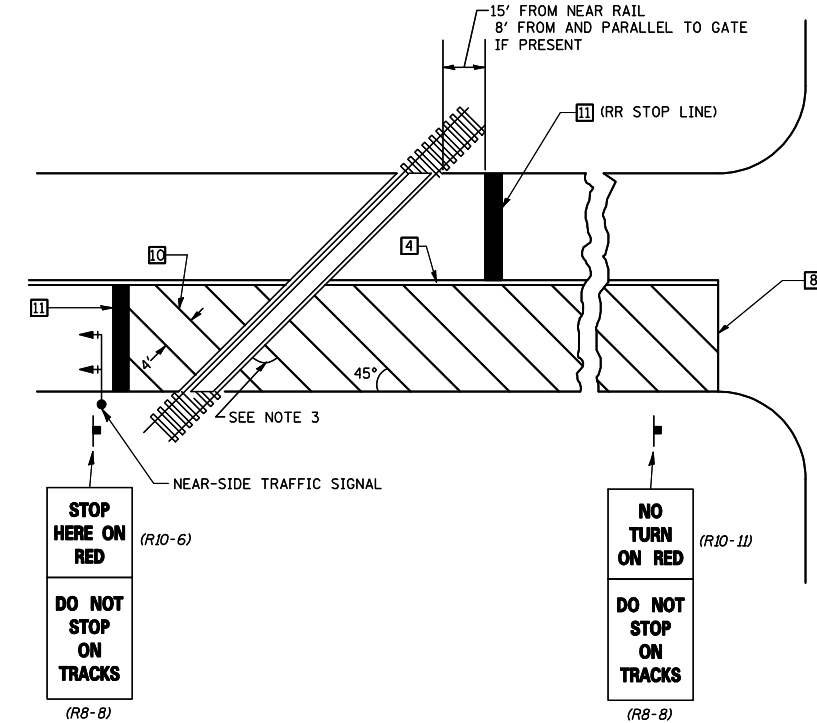
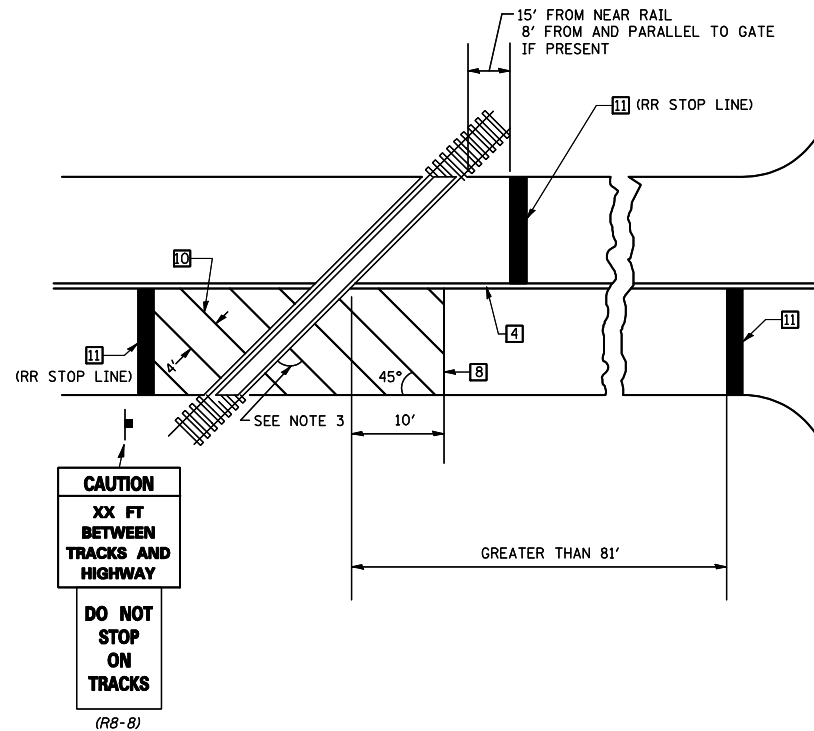

SUPPLEMENTAL PAVEMENT MARKING TREATMENT FOR RAILROAD-HIGHWAY GRADE CROSSING

GENERAL NOTES

- SUPPLEMENTAL PAVEMENT MARKINGS TO BE INSTALLED ONLY ON APPROACHES TO INTERSECTIONS CONTROLLED BY TRAFFIC SIGNALS WHICH ARE INTERCONNECTED WITH THE RAILROAD WARNING SIGNALS.
- EXTEND PAVEMENT MARKINGS TO THE INTERSECTION ONLY WHERE NEAR-SIDE TRAFFIC SIGNALS ARE USED.
- WHERE THE ANGLE BETWEEN THE DIAGONAL PAVEMENT MARKINGS AND THE TRACK WOULD BE LESS THAN 20°, THE PAVEMENT MARKINGS SHOULD BE PLACED IN THE OPPOSITE DIRECTION FROM THAT SHOWN.

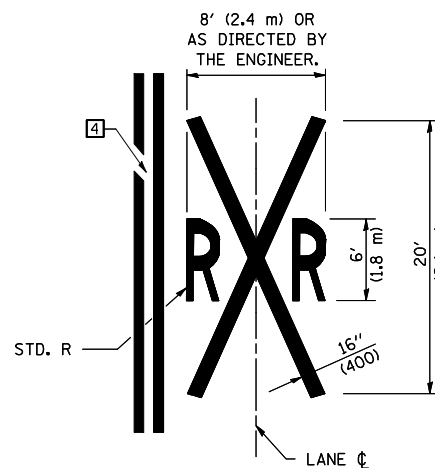

Note: All dimensions are in INCHES (millimeters) unless otherwise shown.

FILE NAME = \$FILEL\$	USER NAME = \$USER\$	DESIGNED -	REVISED - 11/06
		DRAWN -	REVISED - 09/2009 - KJT
	PLOT SCALE = \$SCALE\$	CHECKED -	REVISED -
	PLOT DATE = \$DATE\$	DATE -	REVISED -

STATE OF ILLINOIS
DEPARTMENT OF TRANSPORTATION

PAVEMENT MARKING AND MARKERS
(RURAL & URBAN APPLICATIONS)

SCALE: SHEET NO. 4 OF 4 SHEETS STA. TO STA.

DISTRICT 5 DETAIL NO. 7800AAAA

F.A.P. RTE.	SECTION	COUNTY	TOTAL SHEETS	SHEET NO.
709	(113)RS-1	CHAMPAIGN	65	62
FED. ROAD DIST. NO. ILLINOIS FED. AID PROJECT			CONTRACT NO. 70117	