

STATE OF ILLINOIS
DEPARTMENT OF TRANSPORTATION
DIVISION OF HIGHWAYS

**PROPOSED
HIGHWAY PLANS**

F.A.P. ROUTE 709 (US 136)
SECTION (113R)RS-1
PROJECT ACF-0709(027)
RESURFACING (3P)
CHAMPAIGN COUNTY

F.A.P. RTE.	SECTION	COUNTY	TOTAL SHEETS	SHEET NO.
709	(113R)RS-1	CHAMPAIGN	65	1
FED. ROAD DIST. NO.		ILLINOIS	CONTRACT NO. 70117	

FOR INDEX OF SHEETS, SEE SHEET NO. 2
FOR SUMMARY OF QUANTITIES, SEE SHEET NO'S. 4 - 6

D-95-047-00

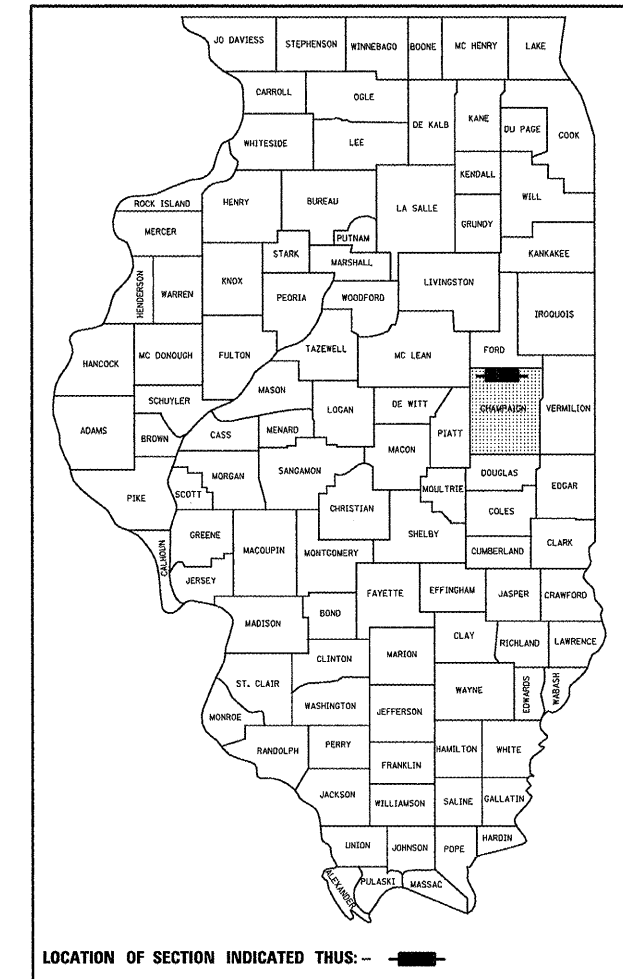

OMISSION FROM SECTION
UNDER I. C. G. RAILROAD
S. N. 010-0233
STA 2290+19.00 TO
STA 2292+45.00

C-95-109-00
E OF SUNVIEW RD TO BETHANY PARK DR IN RANTOUL

OMISSION FROM SECTION
AT US 45 INTERSECTION
STA 2303+23.32 TO
STA 2305+13.70

SECTION ENDS
STATION 105+64.00

SECTION BEGINS
STATION 2270+54.60

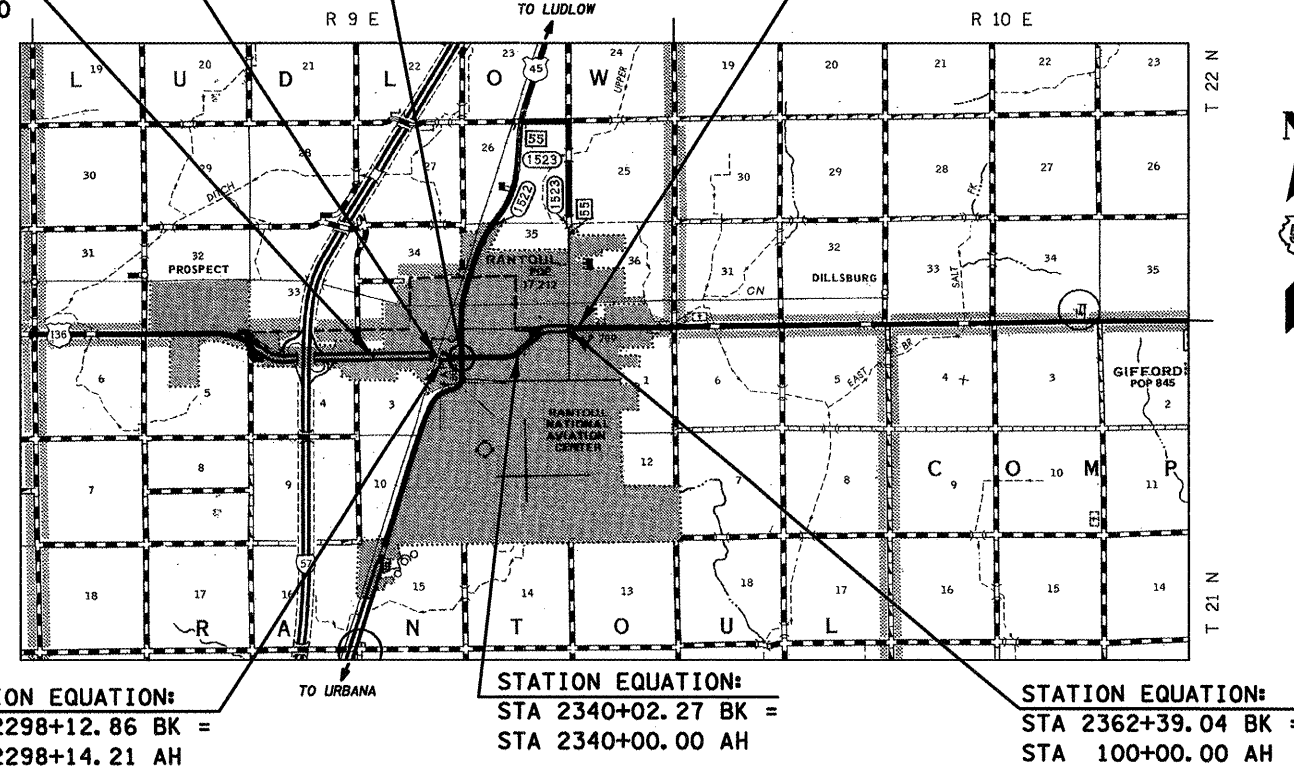

CURRENT TRAFFIC DATA
ADT = 12,600 (2009) 14,700 (2019)
20 YR ADT = 16,900 (2029)
PU & PC % = 94.8
SU % = 3.3
MU % = 1.9

DESIGN DESIGNATION
NA

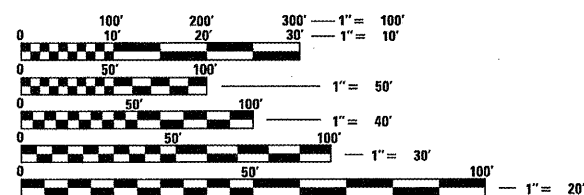

FULL SIZE PLANS HAVE BEEN PREPARED USING STANDARD ENGINEERING SCALES. REDUCED SIZED PLANS WILL NOT CONFORM TO STANDARD SCALES. IN MAKING MEASUREMENTS ON REDUCED PLANS, THE ABOVE SCALES MAY BE USED.

J.U.L.I.E.
JOINT UTILITY LOCATION INFORMATION FOR EXCAVATION
1-800-892-0123
OR 811 (RANTOUL TOWNSHIP)

PROJECT ENGINEER: NANCY FASIG
SQUAD LEADER: BRIAN J. HOGAN
DESIGNER: BILL MURPHY
PHONE: (217)465-4181
CONTRACT NO. 70117

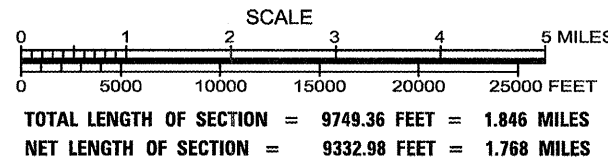

STATE OF ILLINOIS
DEPARTMENT OF TRANSPORTATION
DIVISION OF HIGHWAYS

SUBMITTED 1/29 20 10
Joseph E. Gower
DEPUTY DIRECTOR OF HIGHWAYS, REGION THREE ENGINEER

March 19 20 10
Scott E. Stitt, P.E. &c
ACTING ENGINEER OF DESIGN AND ENVIRONMENT

March 19 20 10
Christine M. Reed &c
DIRECTOR OF HIGHWAYS, CHIEF ENGINEER

**PRINTED BY THE AUTHORITY
OF THE STATE OF ILLINOIS**

INDEX OF SHEETS

SHEET NO.	DESCRIPTION
1	COVER SHEET
2	INDEX OF SHEETS
2	LIST OF HIGHWAY STANDARDS
3	GENERAL NOTES
4-6	SUMMARY OF QUANTITIES
7-21	TYPICAL CROSS SECTIONS
22-35	SCHEDULE OF QUANTITIES
36-55	PLAN SHEETS
56	MAINLINE BUTT JOINTS & HMA RUNDOWNS DETAILS
56	TANNER ST. BUTT JOINTS & HMA RUNDOWNS DETAILS
56	HMA RUNDOWNS AT U.S. 45 OMISSION
56	CLASS D PATCHING DETAIL
57-58	PRIVATE AND COMMERCIAL ENTRANCES DETAIL
59-62	PAVEMENT MARKING AND MARKERS DETAIL
63	PCC PARTIAL DEPTH HMA PATCHING DETAIL
64	SURVEY MARKERS TYPE 1 & 2 (SPECIAL) DETAIL
65	SURVEY MONUMENT COVER ASSEMBLY DETAIL

LIST OF HIGHWAY STANDARDS

STANDARD NO.	DESCRIPTION
000001 - 05	STANDARD SYMBOLS, ABBREVIATIONS, AND PATTERNS
001006	DECIMAL OF AN INCH AND OF A FOOT
442201 - 03	CLASS C AND D PATCHES
701426 - 03	LANE CLOSURE, MULTILANE, INTERMITTENT OR MOVING OPER., FOR SPEEDS GREATER THAN OR EQUAL TO 45 MPH
701602 - 04	URBAN LANE CLOSURE, MULTILANE 2W WITH BIDIRECTIONAL LEFT TURN LANE
701701 - 06	URBAN LANE CLOSURE, MULTILANE INTERSECTION
701901 - 01	TRAFFIC CONTROL DEVICES
780001 - 02	TYPICAL PAVEMENT MARKINGS
781001 - 03	TYPICAL APPLICATIONS OF RAISED REFLECTIVE PAVEMENT MARKINGS
814001 - 02	HANDHOLES
886001 - 01	DETECTOR LOOP INSTALLATIONS
886006 - 01	TYPICAL LAYOUT FOR DETECTION LOOPS

FILE NAME *	USER NAME = *USER*	DESIGNED - ___	REVISED - ___	STATE OF ILLINOIS DEPARTMENT OF TRANSPORTATION	INDEX OF SHEETS & LIST OF HIGHWAY STANDARDS	F.A.P. RTE.	SECTION	COUNTY	TOTAL SHEETS	SHEET NO.
#FILE#		DRAWN - ___	REVISED - ___			709	(113)RS-1	CHAMPAIGN	65	2
PLOT SCALE = *SCALE*	CHECKED - ___	REVISED - ___				CONTRACT NO. 70117				
PLOT DATE = *DATE*	DATE - _____	REVISED - ___				FED. ROAD DIST. NO. _ ILLINOIS FED. AID PROJECT				
				SCALE: N/A		SHEET NO. ___ OF ___ SHEETS		STA. _____ TO STA. _____		

GENERAL NOTES

G.N.-100
ENGLISH UNITS OF MEASUREMENT SHALL GOVERN OVER AND SUPERSEDE ANY METRIC UNITS SHOWN IN THIS CONTRACT. WHERE INCLUDED, METRIC UNITS ARE FOR INFORMATION ONLY.

G.N.-406
THE QUANTITIES INCLUDED IN THE PLANS FOR HOT-MIX ASPHALT RESURFACING ARE INTENDED TO GIVE THE COVERAGE SHOWN ON THE TYPICAL CROSS SECTIONS. IT IS NOT INTENDED TO INCREASE THE THICKNESS OF THE HOT-MIX ASPHALT MIXTURE IN ORDER TO USE ALL OF THE QUANTITIES INCLUDED IN THE CONTRACT.

G.N.-406.05b
ALL LEVELING BINDER OR BINDER SHALL BE GIVEN A FOG COAT OF PRIME BEFORE THE SURFACE COURSE IS PLACED WHEN DIRECTED BY THE ENGINEER.

THE FOG COAT WILL BE PAID FOR AT THE CONTRACT UNIT PRICE PER GALLON FOR BITUMINOUS MATERIAL (PRIME COAT) AND NO ADDITIONAL COMPENSATION WILL BE ALLOWED.

G.N.-406.10
FOR MULTILANE RESURFACING
WHEN BEGINNING THE RESURFACING WITH NEW MIXTURES FOR LEVELING BINDER, BINDER COURSE, AND SURFACE COURSE MIXTURES, THE WORK WILL BE CONFINED TO THE INSIDE TRAFFIC LANE (PASSING LANE) FIRST. THE WORK WILL REMAIN ON THE INSIDE LANE UNTIL THE MIX HAS BEEN ADJUSTED AND APPROVED BY THE ENGINEER BEFORE ANY RESURFACING IS ALLOWED ON THE OUTSIDE (DRIVING) TRAFFIC LANE(S).

ANY DELAYS OR INCONVENIENCES CAUSED THE CONTRACTOR IN COMPLYING WITH THIS REQUIREMENT WILL BE CONSIDERED INCIDENTAL TO THE VARIOUS HOT-MIX ASPHALT PAY ITEMS, AS SHOWN IN THE CONTRACT, AND NO ADDITIONAL COMPENSATION WILL BE ALLOWED.

G.N.-406H -- MIXTURE REQUIREMENTS Contract: 70117

Location	US136	US 136	US 136	US 136
Mixture Use	Polymer Surface	Polymer Level Binder	P.D. and Class D Patching	INCIDENTAL
AC/PG	SBS PG 70-22	SBS PG 70-22	PG 64-22	PG 64-22
RAP % (Max)	10	10	10	15
Design Air Voids	4.0% @ Ndes=90	4.0% @ Ndes=90	4.0% @ Ndes=90	4% @ Ndes=50
Mix Comp(Gradation)	IL 9.5	IL 9.5	IL 19.0	IL 9.5
Friction Aggregate	Mix D	Mix C	N.A.	MIX C

GENERAL NOTES

G.N.-408B
THE INCIDENTAL HOT-MIX ASPHALT SURFACING SHALL BE COMPACTED AS REQUIRED BY THE SPECIFICATIONS FOR DESIGN NUMBER OF GYRATIONS BEING USED,

AT THE FOLLOWING LOCATIONS:

MAPLEWOOD AVENUE

G.N.-442B -- PATCHING SCHEDULES
THE PATCHING SCHEDULES INCLUDED IN THE PLANS REPRESENT THE BEST INFORMATION AVAILABLE AT THE TIME OF COMPLETION OF THE PLANS FOR LETTING. VARIATIONS IN LOCATION AND SIZES OF BOTH FULL-DEPTH AND PARTIAL-DEPTH PATCHES MAY OCCUR.

G.N.-667
THE RESIDENT ENGINEER SHALL CONTACT THE PROGRAM DEVELOPMENT CHIEF OF SURVEYS PRIOR TO THE PRE-CONSTRUCTION CONFERENCE FOR INSTRUCTION AS TO SETTING OF TEMPORARY OR PERMANENT TIES FOR CENTERLINE ALIGNMENT CONTROL SURVEY MARKERS (PCDS, PTDS, AND PDS). PROJECT IMPLEMENTATION PERSONNEL WILL BE RESPONSIBLE FOR SETTING THESE MARKERS.

G.N.-703A
SHORT TERM PAVEMENT MARKING SHALL BE APPLIED TO THE PAVEMENT AFTER ANY OF THE FOLLOWING: COLD MILLING AND/OR PLACING BITUMINOUS MATERIALS (PRIME COAT), LEVELING BINDER (MACHINE METHOD), BINDER AND SURFACE COURSES. SHORT TERM PAVEMENT MARKING PLACED ON THE SURFACE, SHALL COINCIDE WITH THE FINAL PAVEMENT STRIPING. SHORT TERM PAVEMENT MARKING PLACED PRIOR TO THE SURFACE SHALL COINCIDE WITH THE EXISTING PAVEMENT MARKINGS. USE 4 FEET PER 40 FEET (OR 10% PER STATION).

G.N.-781
RAISED REFLECTIVE PAVEMENT MARKERS SHALL BE PLACED IN ACCORDANCE WITH STANDARD 781001, AND THE DETAILS SHOWN IN THE PLANS. IF THERE IS ANY DISCREPANCY BETWEEN THE STANDARD AND THE DETAILS IN THE PLANS, THE DETAILS IN THE PLANS SHALL GOVERN. THE FINAL PAVEMENT MARKINGS SHALL BE IN PLACE PRIOR TO PLACING THE RAISED REFLECTIVE PAVEMENT MARKERS AND THE RAISED REFLECTIVE PAVEMENT MARKERS SHALL BE PLACED MIDWAY IN THE 30 FOOT (9 m) SPACE BETWEEN THE DASHED CENTERLINE STRIPES (WHEN APPLICABLE).

G.N.-1004.01
COARSE AGGREGATE GRADATION CA-10 MAY BE USED WHENEVER COARSE AGGREGATE CA-6 IS SPECIFIED IN THE STANDARD SPECIFICATIONS.

NO COMMITMENTS

FILE NAME =	USER NAME = hoganbj	DESIGNED -	REVISED -	STATE OF ILLINOIS DEPARTMENT OF TRANSPORTATION	GENERAL NOTES	F.A.P. RTE.	SECTION	COUNTY	TOTAL SHEETS	SHEET NO.	
ca:\pwr_work\PWIDOT\HOGANBJ\010446\0574	117-shr-Gernnote.dgn	DRAWN -	REVISED -			709	(113)RS-1	CHAMPAIGN	65	3	
	PLOT SCALE = 100.0000' / IN.	CHECKED -	REVISED -			CONTRACT NO. 70117					
	PLOT DATE = 1/29/2010	DATE -	REVISED -			FED. ROAD DIST. NO. - ILLINOIS FED. AID PROJECT					

SUMMARY OF QUANTITIES (SHEET 1 OF 3)

*URBAN
80/20 FED/ST*

LOCATION OF WORK: FAP ROUTE 709 (US 136)
 CHAMPAIGN COUNTY
 ROADWAY IMPROVEMENTS
 STA. 2270+54.60 - STA. 105+64.00
 URBAN MULTILANE

FUNDING BREAKOUT:
 CONSTRUCTION TYPE CODE: 1000-2A

CODE NO	ITEM	UNIT	TOTAL QUANTITY
40600100	BITUMINOUS MATERIALS (PRIME COAT)	GALLON	6,410.0
40600300	AGGREGATE (PRIME COAT)	TON	193.0
40600845	POLYMERIZED LEVELING BINDER (MACHINE METHOD), N90	TON	3,370.0
40600895	CONSTRUCTING TEST STRIP	EACH	1.0
40600982	HOT- MIX ASPHALT SURFACE REMOVAL- BUTT JOINT	SQ YD	4,175.0
40600985	PORTLAND CEMENT CONCRETE SURFACE REMOVAL- BUTT JOINT	SQ YD	1,530.0
40600990	TEMPORARY RAMP	SQ YD	360.0
40603545	POLYMERIZED HOT-MIX ASPHALT SURFACE COURSE, MIX "D", N90	TON	5,600.0
40800010	BITUMINOUS MATERIALS (PRIME COAT)	GALLON	955.0
40800030	AGGREGATE (PRIME COAT)	TON	15.0
40800050	INCIDENTAL HOT- MIX ASPHALT SURFACING	TON	510.0
44000157	HOT-MIX ASPHALT SURFACE REMOVAL, 2"	SQ YD	44,520.0
44201741	CLASS D PATCHES, TYPE II, 8 INCH	SQ YD	18.0
44201761	CLASS D PATCHES, TYPE I, 10 INCH	SQ YD	33.0
44201765	CLASS D PATCHES, TYPE II, 10 INCH	SQ YD	722.0
44201769	CLASS D PATCHES, TYPE III, 10 INCH	SQ YD	39.0
44201777	CLASS D PATCHES, TYPE II, 11 INCH	SQ YD	454.0
44201781	CLASS D PATCHES, TYPE III, 11 INCH	SQ YD	47.0
44201815	CLASS D PATCHES, TYPE II, 14 INCH	SQ YD	15.0

SUMMARY OF QUANTITIES (SHEET 2 OF 3)

*URBAN
80/20 FED/ST*

LOCATION OF WORK:

FAP ROUTE 709 (US 136)
CHAMPAIGN COUNTY
ROADWAY IMPROVEMENTS
STA. 2270+54.60 - STA. 105+64.00
URBAN MULTILANE

FUNDING BREAKOUT:
CONSTRUCTION TYPE CODE:

1000-2A

CODE NO	ITEM	UNIT	TOTAL QUANTITY
60255500	MANHOLES TO BE ADJUSTED	EACH	41.0
67000500	ENGINEER'S FIELD OFFICE, TYPE B	CAL MO	5.0
67100100	MOBILIZATION	L SUM	1.0
70102632	TRAFFIC CONTROL AND PROTECTION, STANDARD 701602	L SUM	1.0
70102635	TRAFFIC CONTROL AND PROTECTION, STANDARD 701701	L SUM	1.0
70300100	SHORT- TERM PAVEMENT MARKING	FOOT	13,150.0
70300210	TEMPORARY PAVEMENT MARKING- LETTERS AND SYMBOLS	SQ FT	1,622.0
70300220	TEMPORARY PAVEMENT MARKING- LINE 4"	FOOT	27,050.0
70300240	TEMPORARY PAVEMENT MARKING- LINE 6"	FOOT	2,325.0
70300260	TEMPORARY PAVEMENT MARKING- LINE 12"	FOOT	300.0
70300280	TEMPORARY PAVEMENT MARKING- LINE 24"	FOOT	450.0
70301000	WORK ZONE PAVEMENT MARKING REMOVAL	SQ FT	14,625.0
* 78000100	THERMOPLASTIC PAVEMENT MARKING - LETTERS AND SYMBOLS	SQ FT	1,622.0
* 78000200	THERMOPLASTIC PAVEMENT MARKING - LINE 4"	FOOT	27,050.0
* 78000400	THERMOPLASTIC PAVEMENT MARKING - LINE 6"	FOOT	2,325.0
* 78000600	THERMOPLASTIC PAVEMENT MARKING- LINE 12"	FOOT	300.0
* 78000650	THERMOPLASTIC PAVEMENT MARKING - LINE 24"	FOOT	450.0
* 78100100	RAISED REFLECTIVE PAVEMENT MARKER	EACH	735.0
78300200	RAISED REFLECTIVE PAVEMENT MARKER REMOVAL	EACH	735.0

FILE NAME =	USER NAME = hoganbj	DESIGNED -	REVISED -	STATE OF ILLINOIS DEPARTMENT OF TRANSPORTATION	SUMMARY OF QUANTITIES	F.A.P. RTE.	SECTION	COUNTY	TOTAL SHEETS	SHEET NO.	
ct:\pwork\PIWIDOT\HOGANBJ\40104446\057	117-shr-500.dgn	DRAWN -	REVISED -			709	013RIRS-1	CHAMPAIGN	65	5	
	PLOT SCALE = 100.0000 / IN.	CHECKED -	REVISED -			CONTRACT NO. 70117					
	PLOT DATE = 1/29/2010	DATE -	REVISED -			SCALE: N/A	SHEET NO. 2 OF 3 SHEETS	STA. _____	TO STA. _____	FED. ROAD DIST. NO. _____	ILLINOIS FED. AID PROJECT

SUMMARY OF QUANTITIES (SHEET 3 OF 3)

URBAN
80/20 FED/ST
 LOCATION OF WORK: FAP ROUTE 709 (US 136)
 CHAMPAIGN COUNTY
 ROADWAY IMPROVEMENTS
 STA. 2270+54.60 - STA. 105+64.00
 URBAN MULTILANE
 FUNDING BREAKOUT:
 CONSTRUCTION TYPE CODE: I000-2A

CODE NO	ITEM	UNIT	TOTAL QUANTITY
* 81012300	CONDUIT IN TRENCH, 1" DIA., PVC	FOOT	20.0
* 81012500	CONDUIT IN TRENCH, 1 1/2" DIA., PVC	FOOT	4.0
* 81400100	HANDHOLE	EACH	2.0
* 81900200	TRENCH AND BACKFILL FOR ELECTRICAL WORK	FOOT	24.0
* 88600100	DETECTOR LOOP, TYPE I	FOOT	1,008.0
X0301232	SURVEY MARKER VAULT	EACH	3.0
X0325808	PORTLAND CEMENT CONCRETE SURFACE REMOVAL 2"	SQ YD	280.0
X4401705	PARTIAL DEPTH REMOVAL	SQ YD	220.0
X4421000	PARTIAL DEPTH PATCHING	TON	74.0
XZ193400	SURVEY MARKER, TYPE 2 (SPECIAL)	EACH	2.0
Z0010900	COLD MILLING (SPECIAL)	FOOT	11,661.0

* DENOTES SPECIALTY ITEM

EXISTING TYPICAL SECTION

STATION TO STATION
2270+54.60 2286+79.35

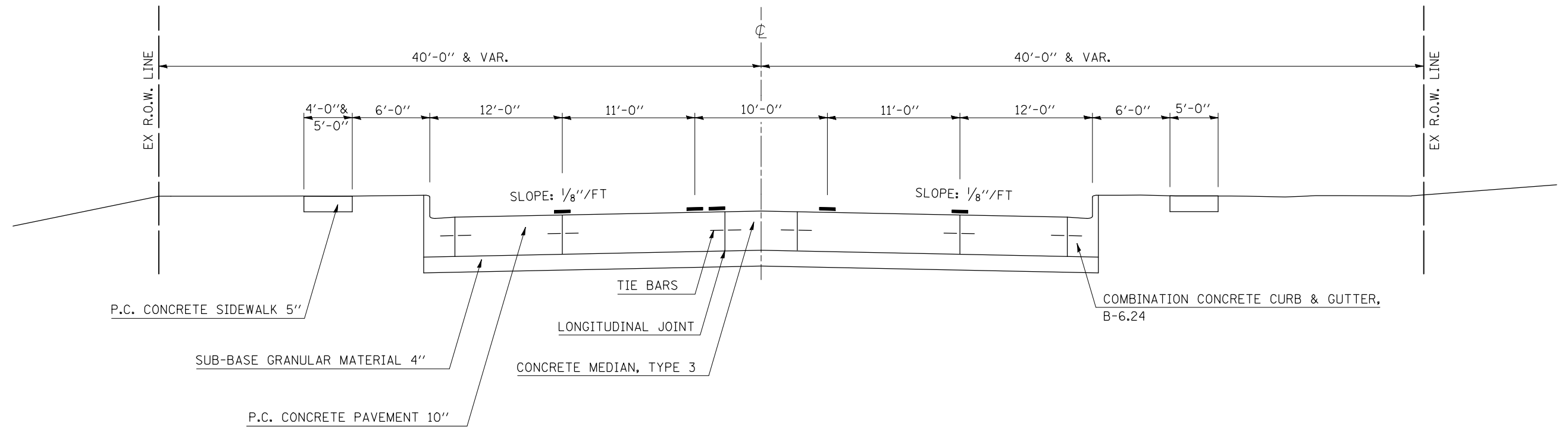

1 PROPOSED TYPICAL SECTION

STATION TO STATION
2270+54.60 2286+79.35 2

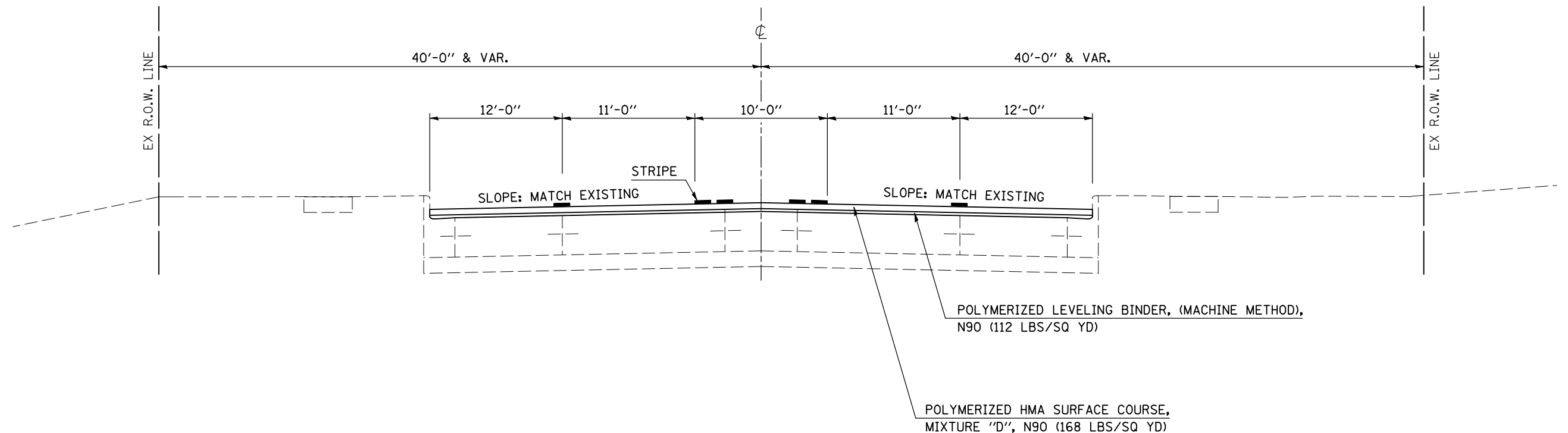

FILE NAME =	USER NAME = hoganbj	DESIGNED -	REVISED -
ct:\pwwork\pwidot\HOGANBJ\d0104446\D570117-sh-typicals.dgn		DRAWN -	REVISED -
		CHECKED -	REVISED -
		DATE -	REVISED -

**STATE OF ILLINOIS
DEPARTMENT OF TRANSPORTATION**

EXISTING AND PROPOSED TYPICAL SECTION

SCALE: N/A SHEET NO. 1 OF 15 SHEETS STA. TO STA.

F.A.P. RTE.	SECTION	COUNTY	TOTAL SHEETS	SHEET NO.
709	(113)RS-1	CHAMPAIGN	65	7
FED. ROAD DIST. NO. ILLINOIS FED. AID PROJECT			CONTRACT NO. 70117	

EXISTING TYPICAL SECTION

STATION TO STATION
2286+79.35 2296+90.00

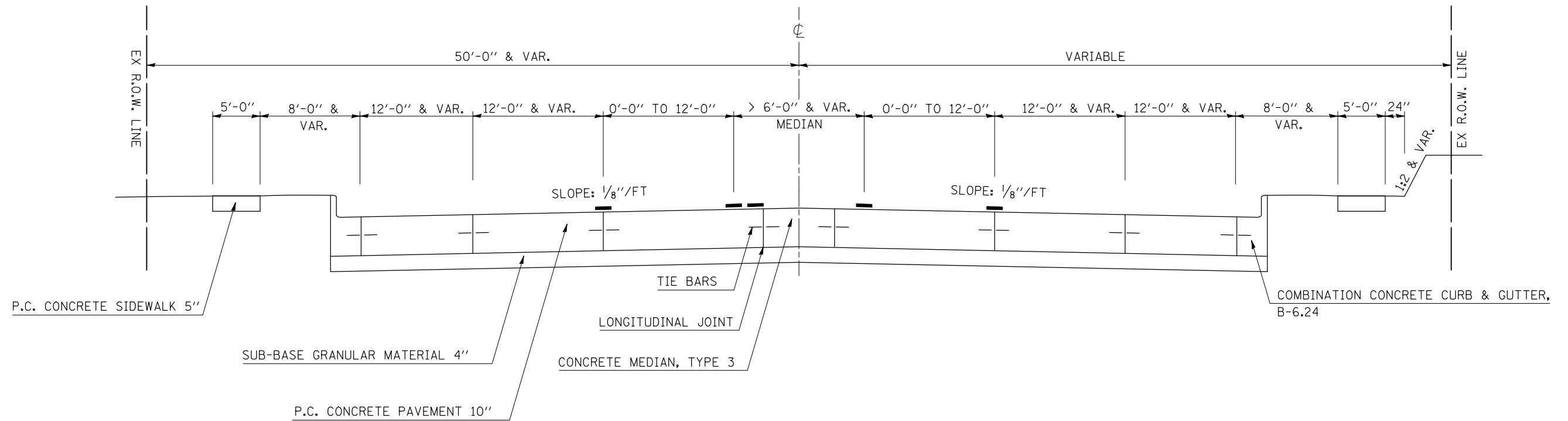

2 PROPOSED TYPICAL SECTION

STATION TO STATION
 ① 2286+79.35 2290+19.00 (R. R. OMISSION)
 2292+45.00 2296+90.00 ③

AREA OUTSIDE SUBWAY

AREA THROUGH SUBWAY

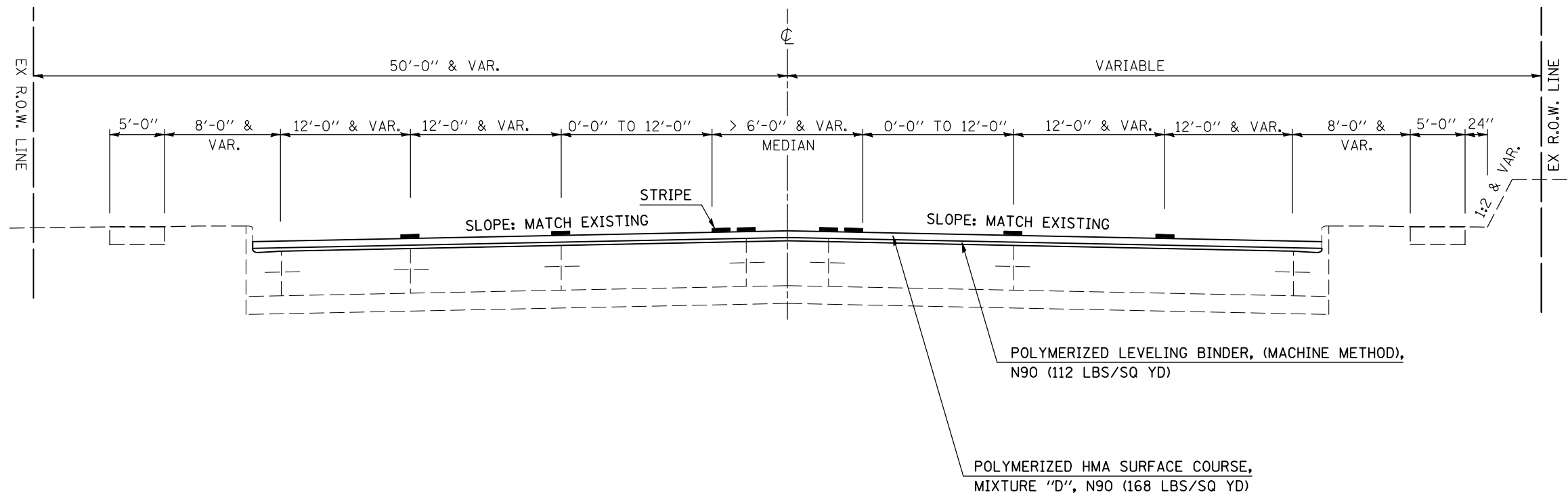

FILE NAME =	USER NAME = hoganbj	DESIGNED -	REVISED -
ct:\pwwork\pwwid\HOGANBJ\d0104446\0570117-sh-typicals.dgn		DRAWN -	REVISED -
		CHECKED -	REVISED -
		DATE -	REVISED -

STATE OF ILLINOIS
DEPARTMENT OF TRANSPORTATION

EXISTING AND PROPOSED TYPICAL SECTION

SCALE: N/A SHEET NO. 2 OF 15 SHEETS STA. TO STA.

F.A.P. RTE.	SECTION	COUNTY	TOTAL SHEETS	SHEET NO.
709	(113)RS-1	CHAMPAIGN	65	8
FED. ROAD DIST. NO. ILLINOIS FED. AID PROJECT			CONTRACT NO. 70117	

EXISTING TYPICAL SECTION

STATION TO STATION
 2296+90.00 2298+12.86 (BK)
 2298+14.21 (AH) 2299+15.32

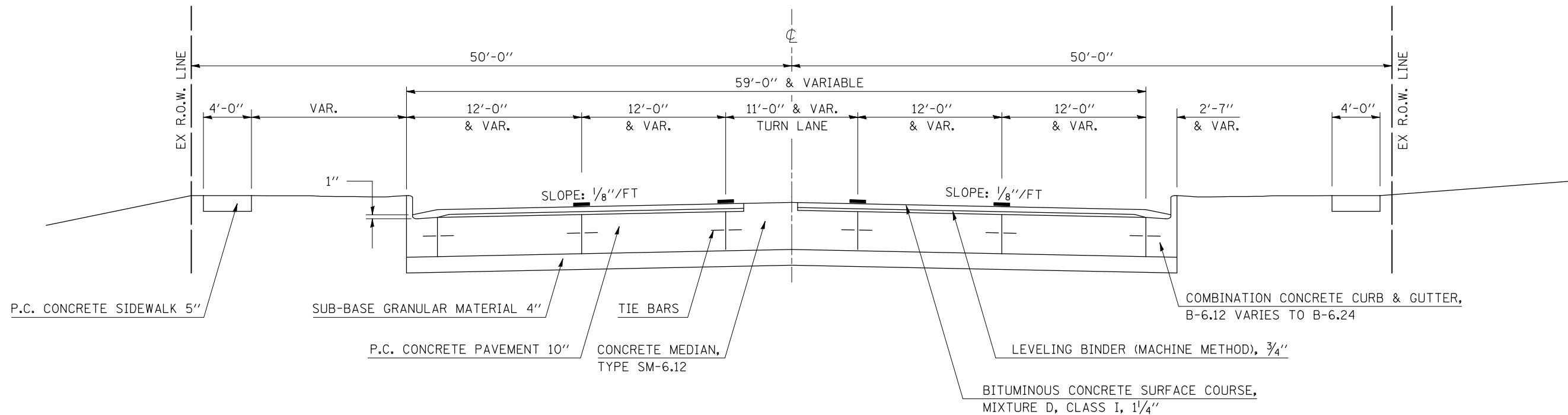

③ PROPOSED TYPICAL SECTION

STATION TO STATION
 ② 2296+90.00 2298+12.86 (BK)
 2298+14.21 (AH) 2299+15.32 ④

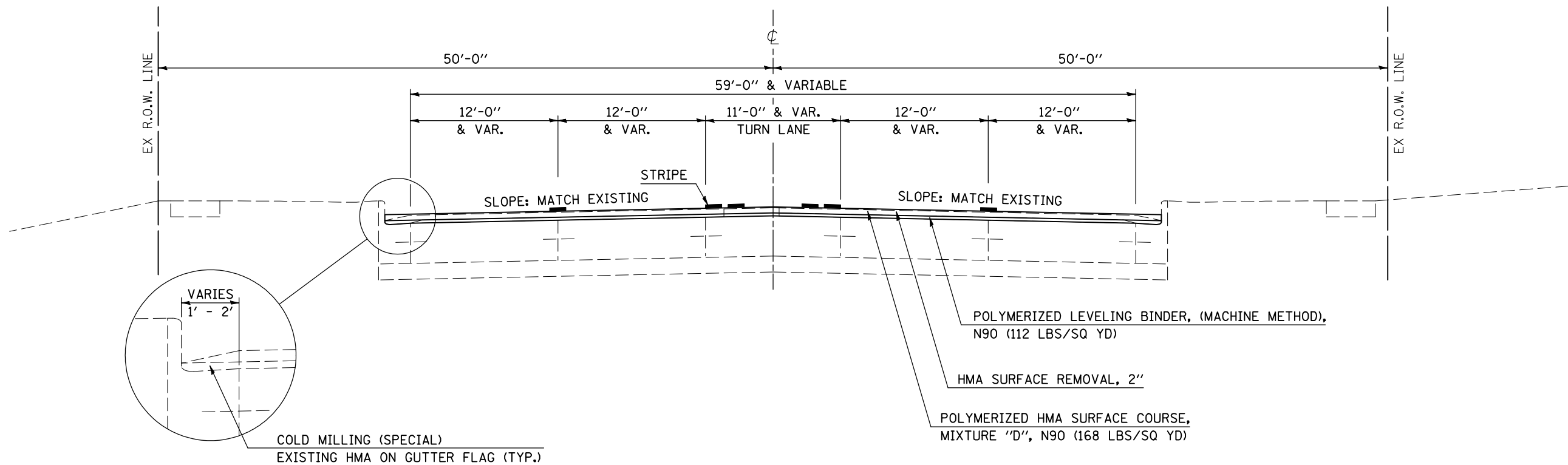

FILE NAME =	USER NAME = hoganbj	DESIGNED -	REVISED -
ct:\pw\work\PWIDOT\HOGANBJ\d0104446\D570117-shd-Typicals.dgn		DRAWN -	REVISED -
		CHECKED -	REVISED -
		DATE -	REVISED -

**STATE OF ILLINOIS
 DEPARTMENT OF TRANSPORTATION**

EXISTING AND PROPOSED TYPICAL SECTION

SCALE: N/A SHEET NO. 3 OF 15 SHEETS STA. TO STA.

F.A.P. RTE.	SECTION	COUNTY	TOTAL SHEETS	SHEET NO.
709	(113)RS-1	CHAMPAIGN	65	9
FED. ROAD DIST. NO. ILLINOIS FED. AID PROJECT			CONTRACT NO. 70117	

EXISTING TYPICAL SECTION

STATION TO STATION
2299+15.32 2300+50.00

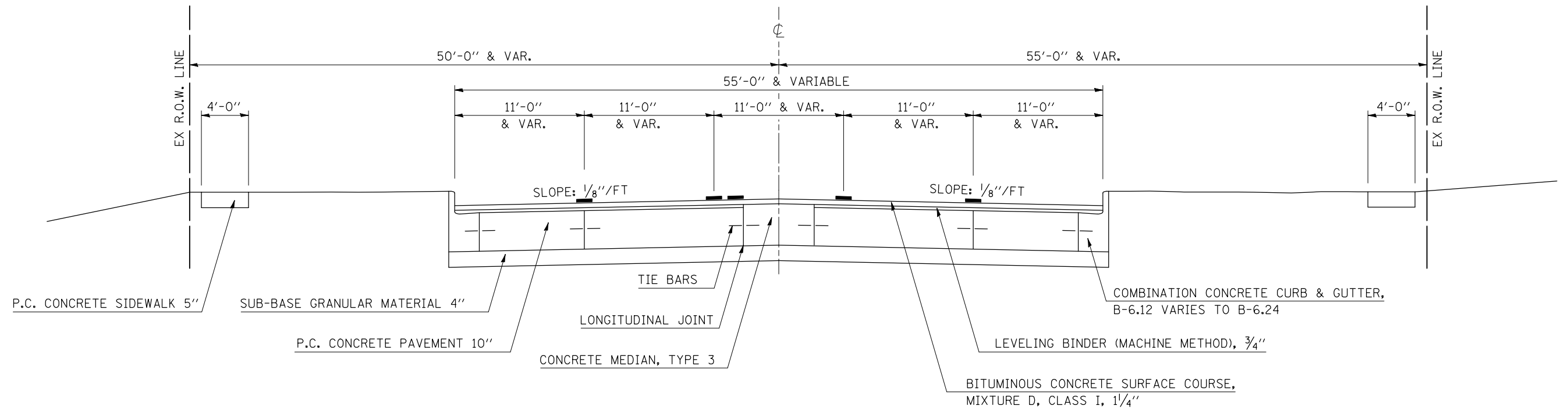

④ PROPOSED TYPICAL SECTION

STATION TO STATION
③ 2299+15.32 2300+50.00 ⑤

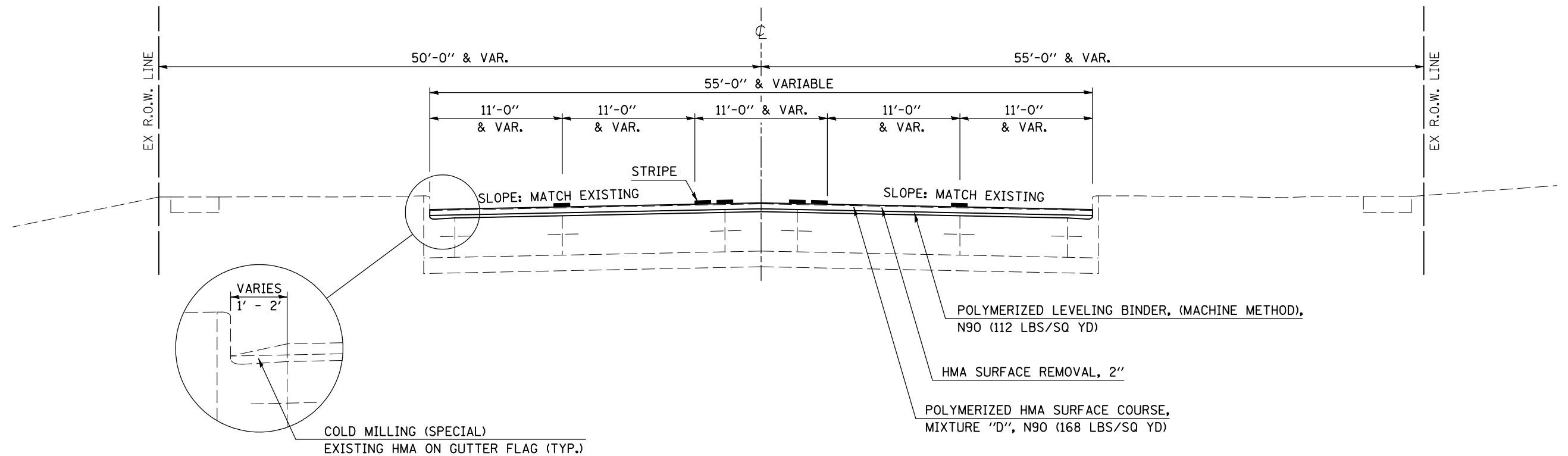

FILE NAME =	USER NAME = hoganbj	DESIGNED -	REVISED -
ct:\pwork\pwidot\HOGANBJ\d0104446\D570117-shd-Typicals.dgn		DRAWN -	REVISED -
		CHECKED -	REVISED -
		DATE -	REVISED -

**STATE OF ILLINOIS
DEPARTMENT OF TRANSPORTATION**

EXISTING AND PROPOSED TYPICAL SECTION

SCALE: N/A SHEET NO. 4 OF 15 SHEETS STA. TO STA.

F.A.P. RTE.	SECTION	COUNTY	TOTAL SHEETS	SHEET NO.
709	(113)RS-1	CHAMPAIGN	65	10
FED. ROAD DIST. NO. ILLINOIS FED. AID PROJECT			CONTRACT NO. 70117	

EXISTING TYPICAL SECTION

STATION TO STATION
 2300+50.00 2301+71.70
 2306+73.40 2319+07.00

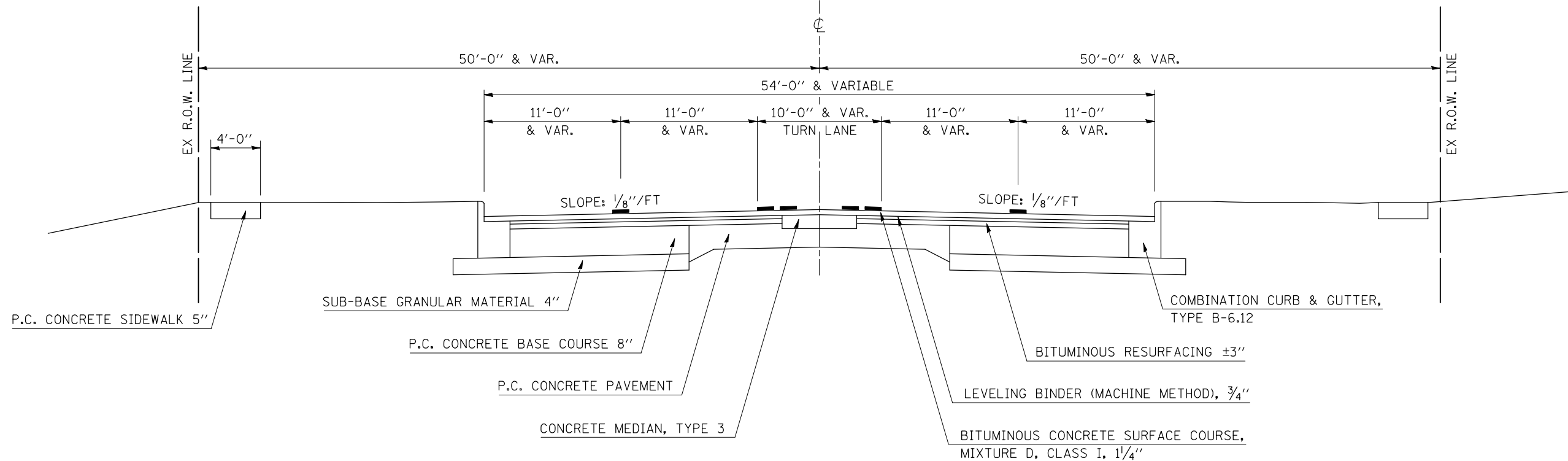

5 PROPOSED TYPICAL SECTION

STATION TO STATION
 ④ 2300+50.00 2301+71.70 ⑥
 ⑥ 2306+73.40 2319+07.00 ⑦

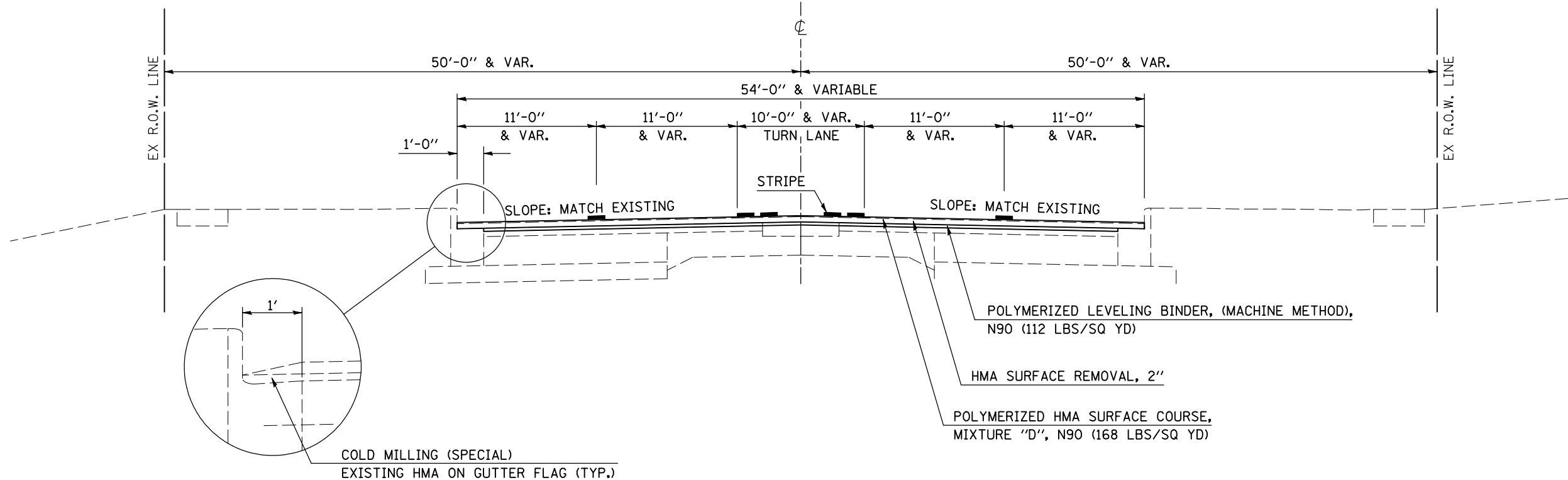

FILE NAME =	USER NAME = hoganbj	DESIGNED -	REVISED -
ct:\pw\work\PWIDOT\HOGANBJ\d0104446\D570117-sh-typicals.dgn		DRAWN -	REVISED -
		CHECKED -	REVISED -
		DATE -	REVISED -

**STATE OF ILLINOIS
 DEPARTMENT OF TRANSPORTATION**

EXISTING AND PROPOSED TYPICAL SECTION

SCALE: N/A SHEET NO. 5 OF 15 SHEETS STA. TO STA.

F.A.P. RTE.	SECTION	COUNTY	TOTAL SHEETS	SHEET NO.
709	(113)RS-1	CHAMPAIGN	65	11
CONTRACT NO. 70117				
FED. ROAD DIST. NO. ILLINOIS FED. AID PROJECT				

EXISTING TYPICAL SECTION

STATION TO STATION
2301+71.70 2306+73.40

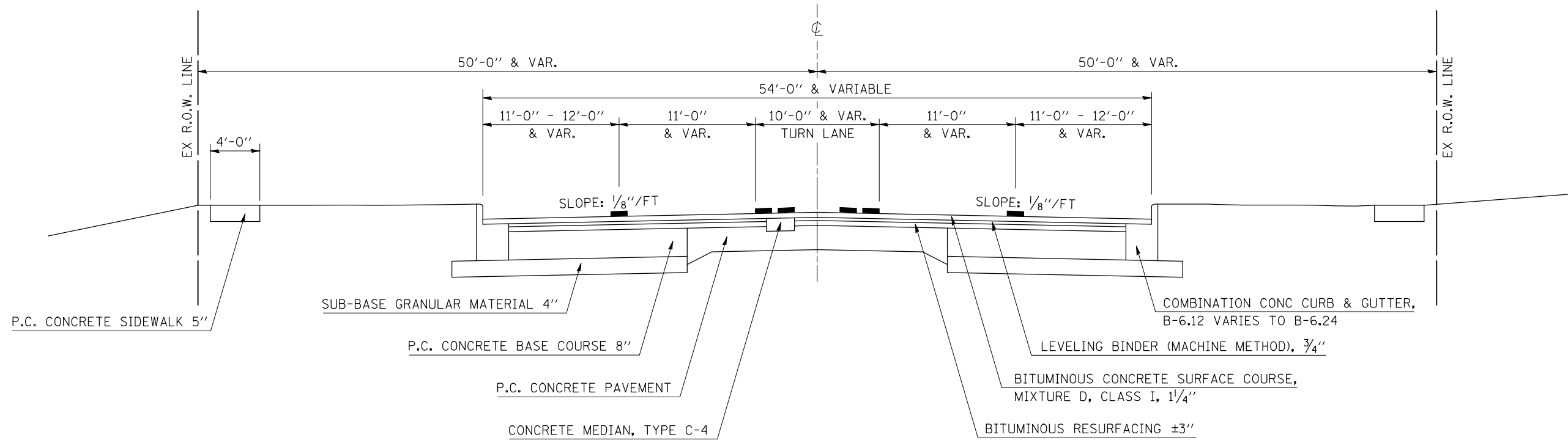

⑥ PROPOSED TYPICAL SECTION

STATION TO STATION
⑤ 2301+71.70 2303+23.32 (RESURFACING OMISSION)
2305+13.70 2306+73.40 ⑤

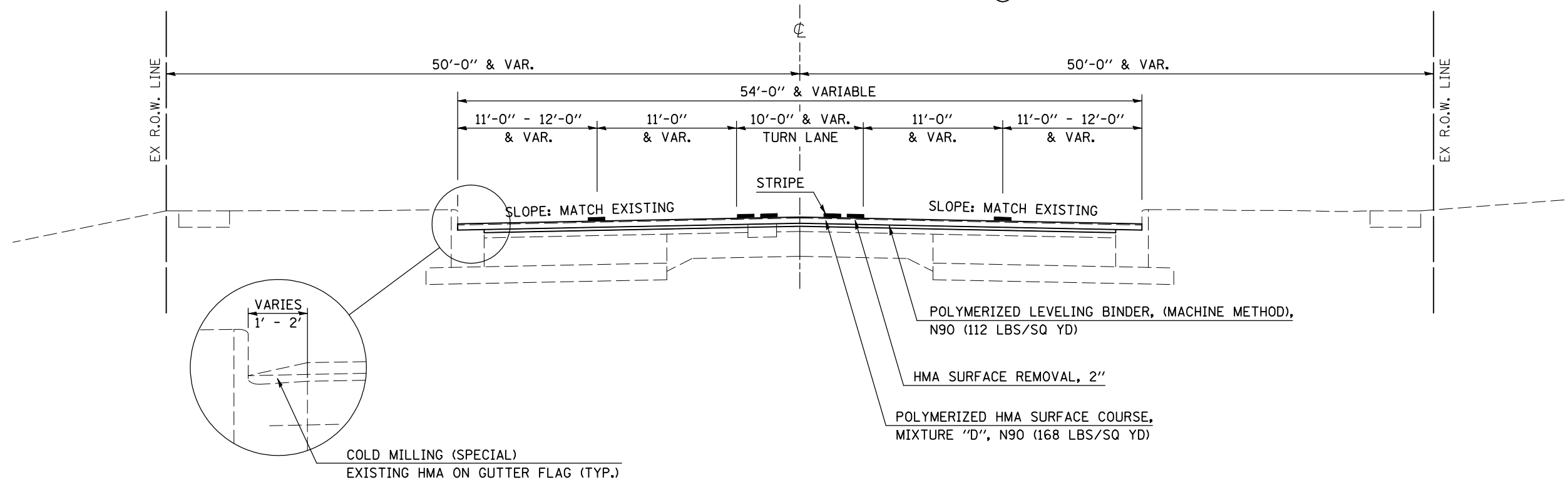

FILE NAME =	USER NAME = hoganbj	DESIGNED -	REVISED -
ct:\pwwork\pwidot\HOGANBJ\d0104446\D570117-sh-typicals.dgn		DRAWN -	REVISED -
		CHECKED -	REVISED -
		DATE -	REVISED -

**STATE OF ILLINOIS
DEPARTMENT OF TRANSPORTATION**

EXISTING AND PROPOSED TYPICAL SECTION

SCALE: N/A SHEET NO. 6 OF 15 SHEETS STA. TO STA.

F.A.P. RTE.	SECTION	COUNTY	TOTAL SHEETS	SHEET NO.
709	(113)RS-1	CHAMPAIGN	65	12
CONTRACT NO. 70117				
FED. ROAD DIST. NO. ILLINOIS FED. AID PROJECT				

EXISTING TYPICAL SECTION

STATION TO STATION
2319+07.00 2324+50.00

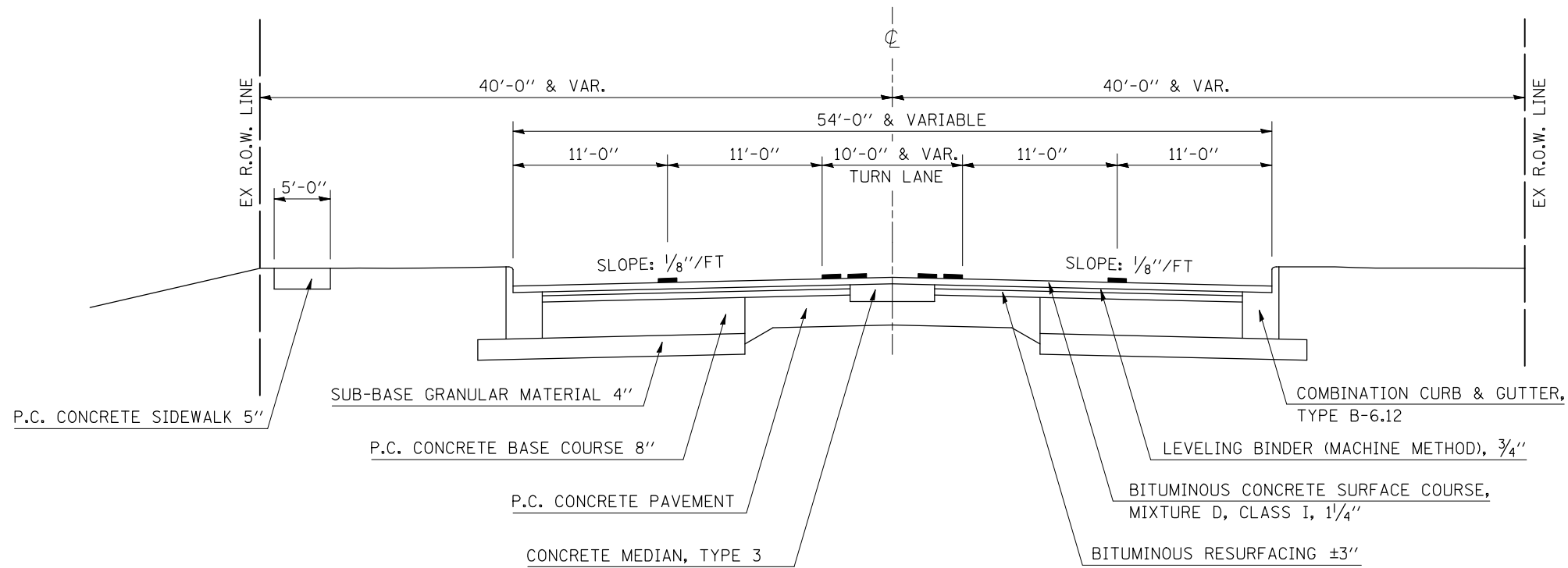

7 PROPOSED TYPICAL SECTION

STATION TO STATION
⑤ 2319+07.00 2324+50.00 ⑧

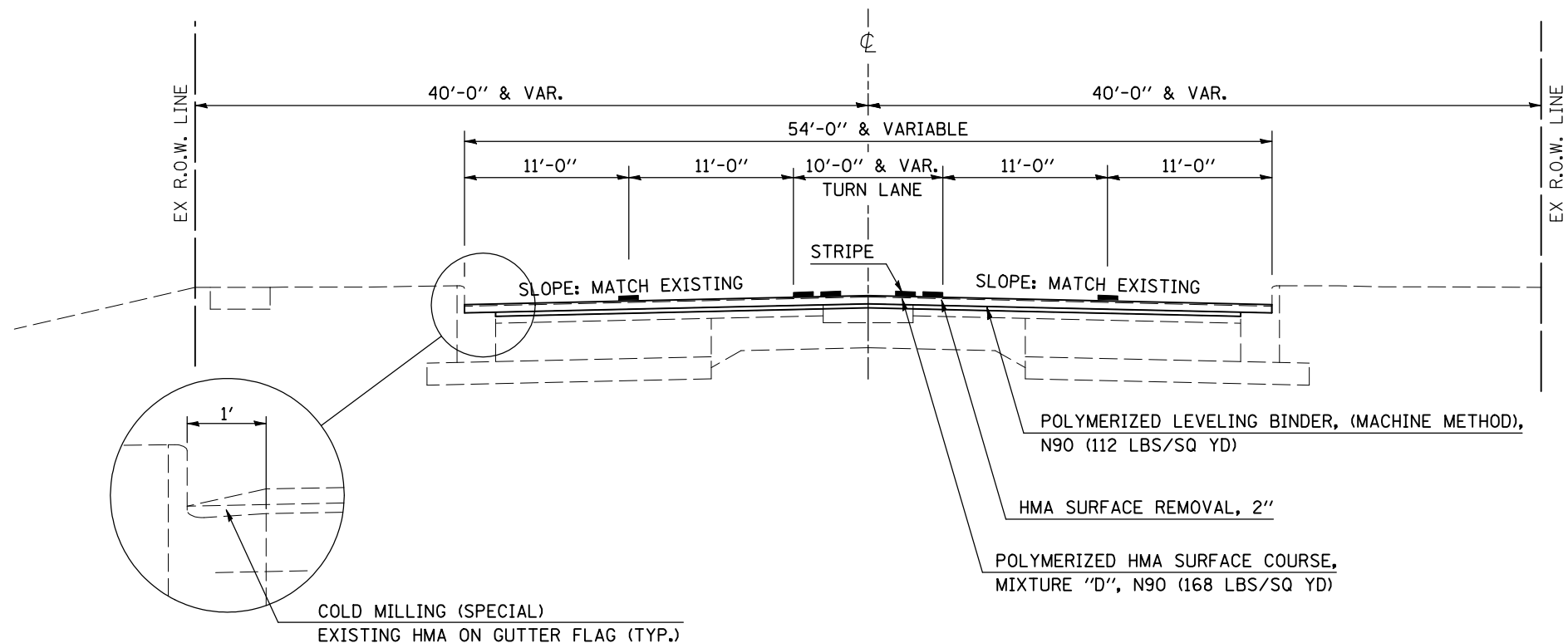

FILE NAME =	USER NAME = hoganbj	DESIGNED -	REVISED -
ct:\pw\work\PWIDOT\HOGANBJ\d0104446\D570117-shd-Typicals.dgn		DRAWN -	REVISED -
PLOT SCALE = 40.0000' / IN.		CHECKED -	REVISED -
PLOT DATE = 1/29/2010		DATE -	REVISED -

**STATE OF ILLINOIS
DEPARTMENT OF TRANSPORTATION**

EXISTING AND PROPOSED TYPICAL SECTION

SCALE: N/A SHEET NO. 7 OF 15 SHEETS STA. TO STA.

F.A.P. RTE.	SECTION	COUNTY	TOTAL SHEETS	SHEET NO.
709	(113)RS-1	CHAMPAIGN	65	13
FED. ROAD DIST. NO. ILLINOIS FED. AID PROJECT			CONTRACT NO. 70117	

EXISTING TYPICAL SECTION

STATION TO STATION
2324+50.00 2345+50.00

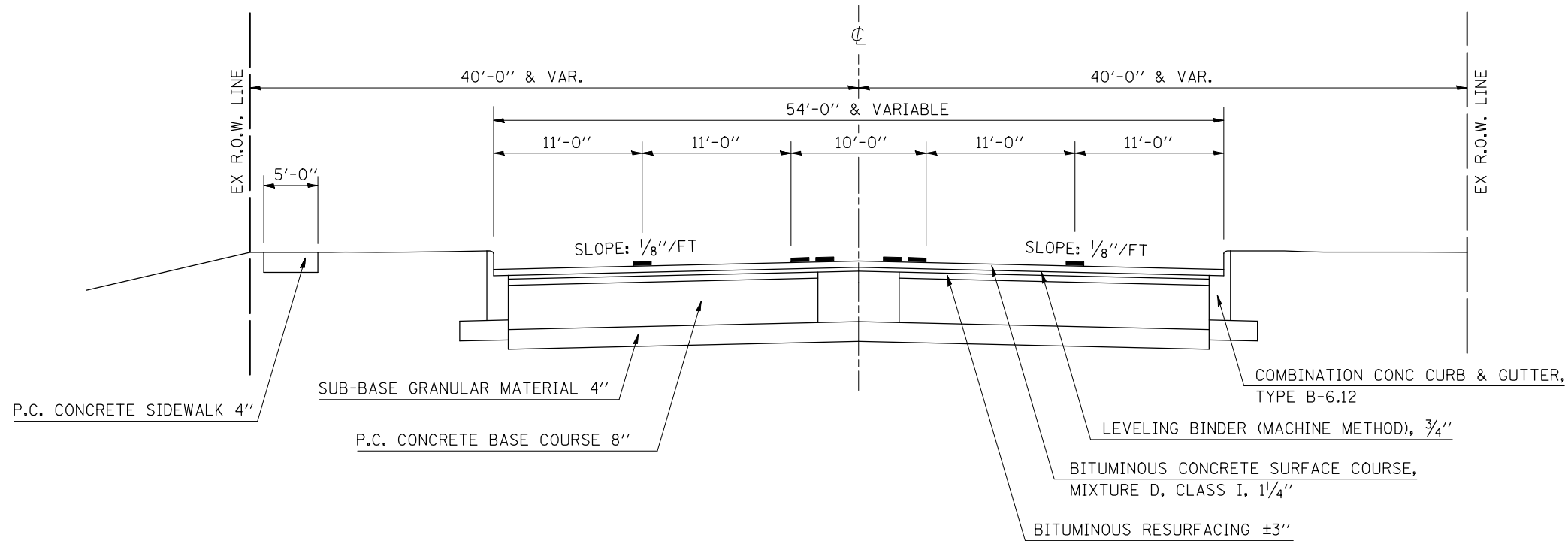

⑧ PROPOSED TYPICAL SECTION

STATION TO STATION
⑦ 2324+50.00 2345+50.00 ⑨

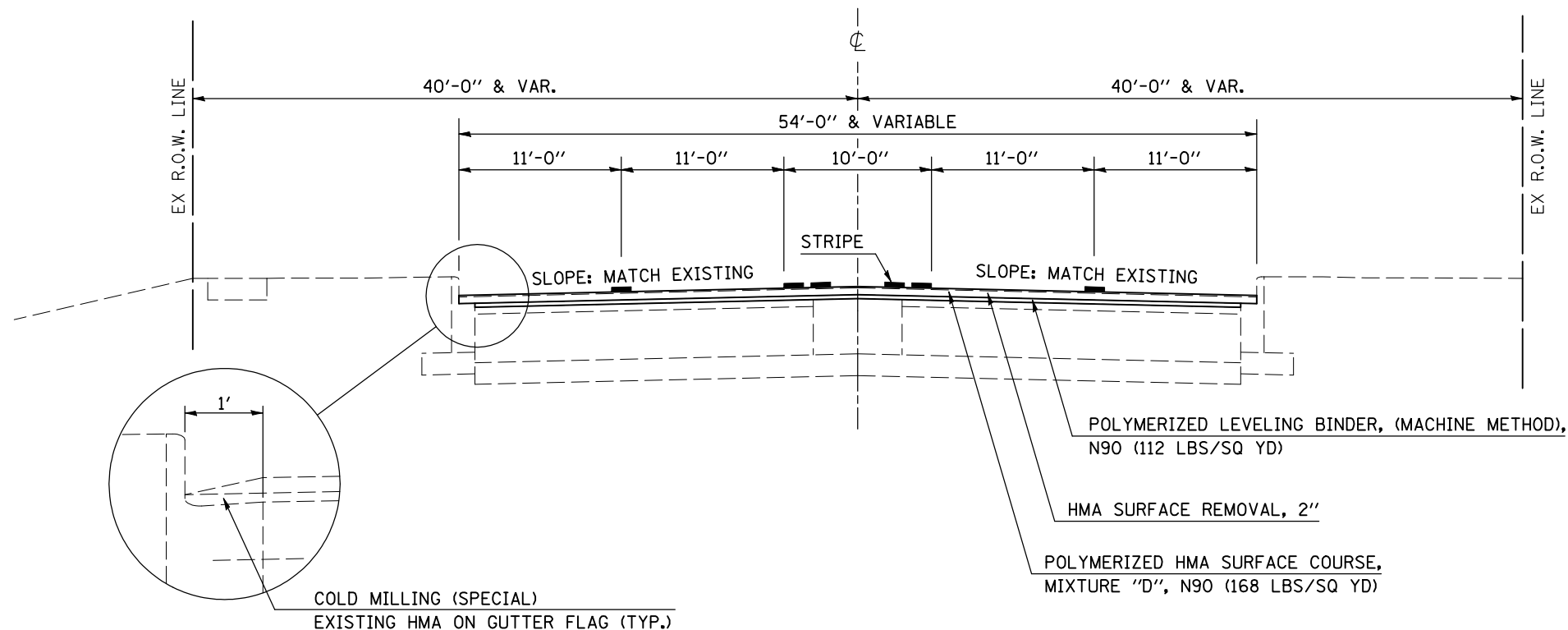

FILE NAME =	USER NAME = hoganbj	DESIGNED -	REVISED -
ct:\pwork\pwork\HOGANBJ\d0104446\0570117-shd-Typicals.dgn		DRAWN -	REVISED -
PLOT SCALE = 40.0000' / IN.		CHECKED -	REVISED -
PLOT DATE = 1/29/2010		DATE -	REVISED -

**STATE OF ILLINOIS
DEPARTMENT OF TRANSPORTATION**

EXISTING AND PROPOSED TYPICAL SECTION

SCALE: N/A SHEET NO. 8 OF 15 SHEETS STA. TO STA.

F.A.P. RTE.	SECTION	COUNTY	TOTAL SHEETS	SHEET NO.
709	(113)RS-1	CHAMPAIGN	65	14
FED. ROAD DIST. NO. ILLINOIS FED. AID PROJECT			CONTRACT NO. 70117	

EXISTING TYPICAL SECTION

STATION TO STATION
2345+50.00 2349+60.04

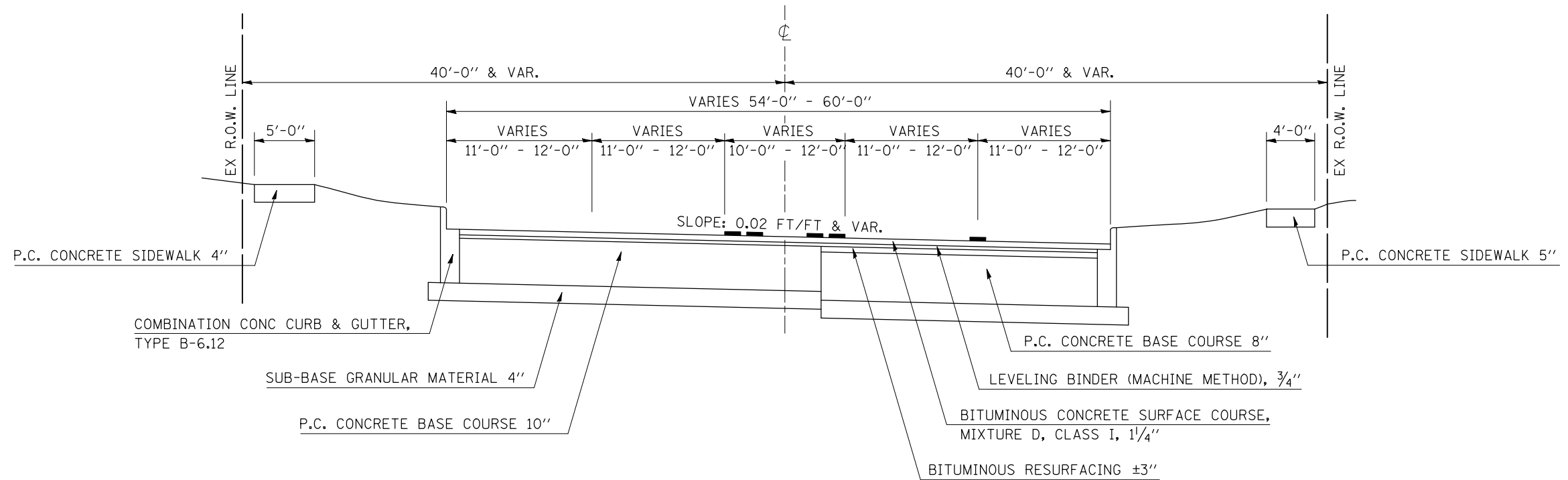

9 PROPOSED TYPICAL SECTION

STATION TO STATION
⑧ 2345+50.00 2349+60.04 ⑩

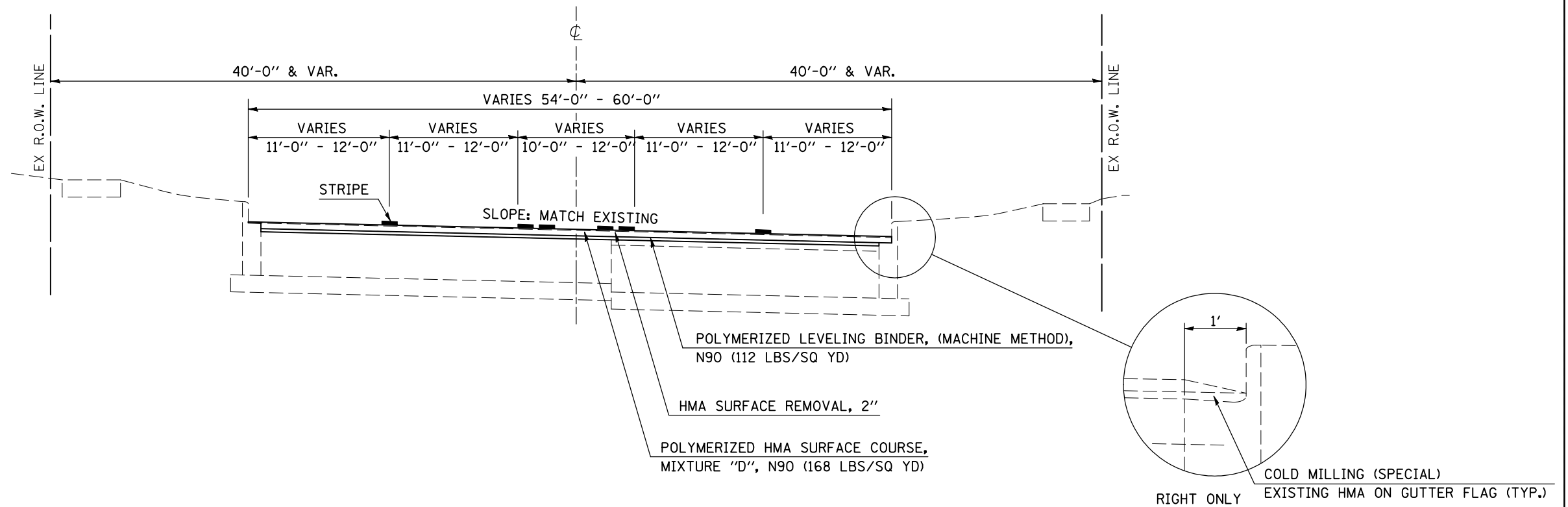

FILE NAME =	USER NAME = hoganbj	DESIGNED -	REVISED -
ct:\pw\work\PWIDOT\HOGANBJ\d0104446\D574	117-shr-Typicals.dgn	DRAWN -	REVISED -
	PLOT SCALE = 40.0000' / IN.	CHECKED -	REVISED -
	PLOT DATE = 1/29/2010	DATE -	REVISED -

**STATE OF ILLINOIS
DEPARTMENT OF TRANSPORTATION**

EXISTING AND PROPOSED TYPICAL SECTION

SCALE: N/A SHEET NO. 9 OF 15 SHEETS STA. TO STA.

F.A.P. RTE.	SECTION	COUNTY	TOTAL SHEETS	SHEET NO.
709	(113)RS-1	CHAMPAIGN	65	15
FED. ROAD DIST. NO. ILLINOIS FED. AID PROJECT			CONTRACT NO. 70117	

EXISTING TYPICAL SECTION

STATION TO STATION
2349+60.04 2354+85.00

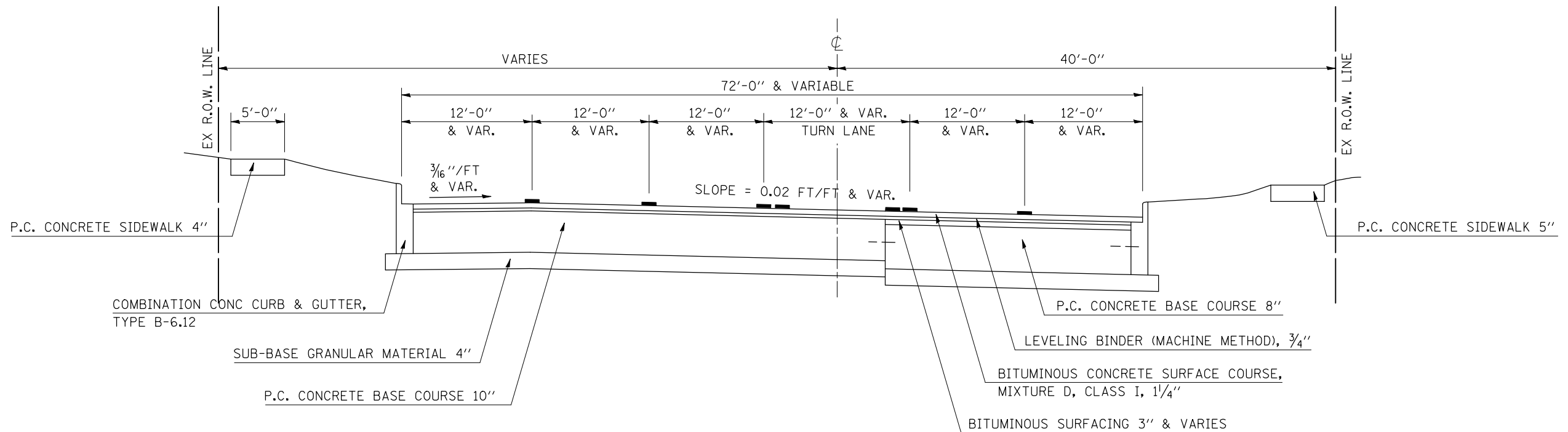

10 PROPOSED TYPICAL SECTION

STATION TO STATION
⑨ 2349+60.04 2354+85.00 ⑪

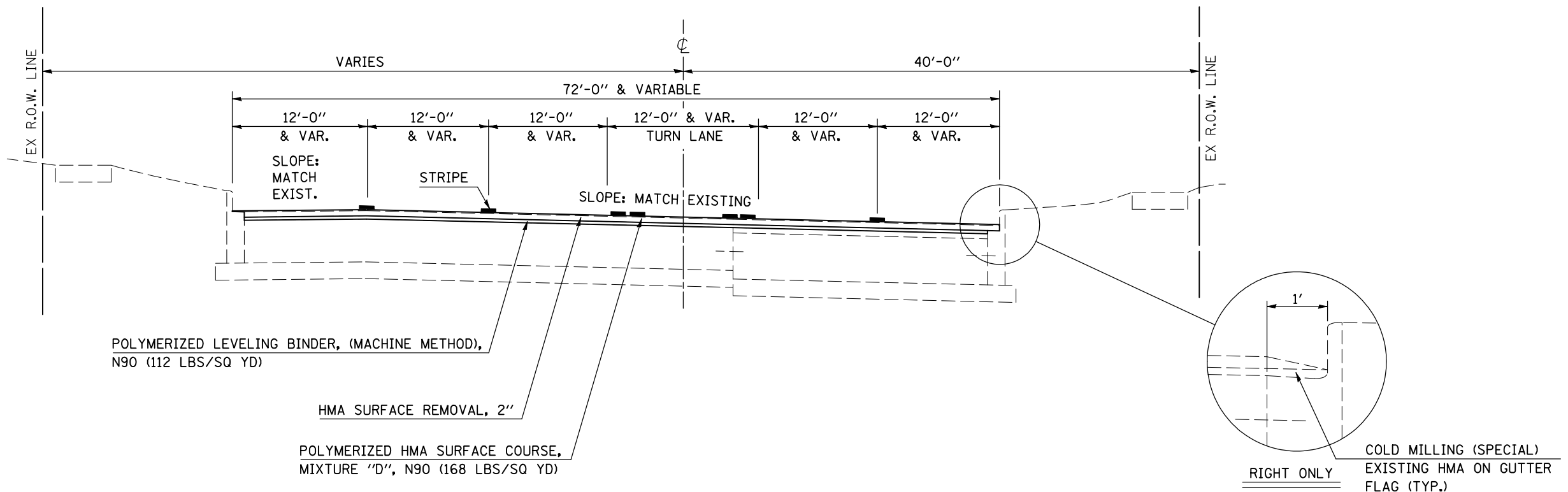

FILE NAME =	USER NAME = hoganbj	DESIGNED -	REVISED -
ct:\pw\work\PWIDOT\HOGANBJ\d0104446\D570	117-shd-Typicals.dgn	DRAWN -	REVISED -
	PLOT SCALE = 40.0000' / IN.	CHECKED -	REVISED -
	PLOT DATE = 1/29/2010	DATE -	REVISED -

**STATE OF ILLINOIS
DEPARTMENT OF TRANSPORTATION**

EXISTING AND PROPOSED TYPICAL SECTION

SCALE: N/A SHEET NO. 10 OF 15 SHEETS STA. TO STA.

F.A.P. RTE.	SECTION	COUNTY	TOTAL SHEETS	SHEET NO.
709	(113)RS-1	CHAMPAIGN	65	16
FED. ROAD DIST. NO. ILLINOIS FED. AID PROJECT			CONTRACT NO. 70117	

EXISTING TYPICAL SECTION

STATION TO STATION
2354+85.00 2356+00.00

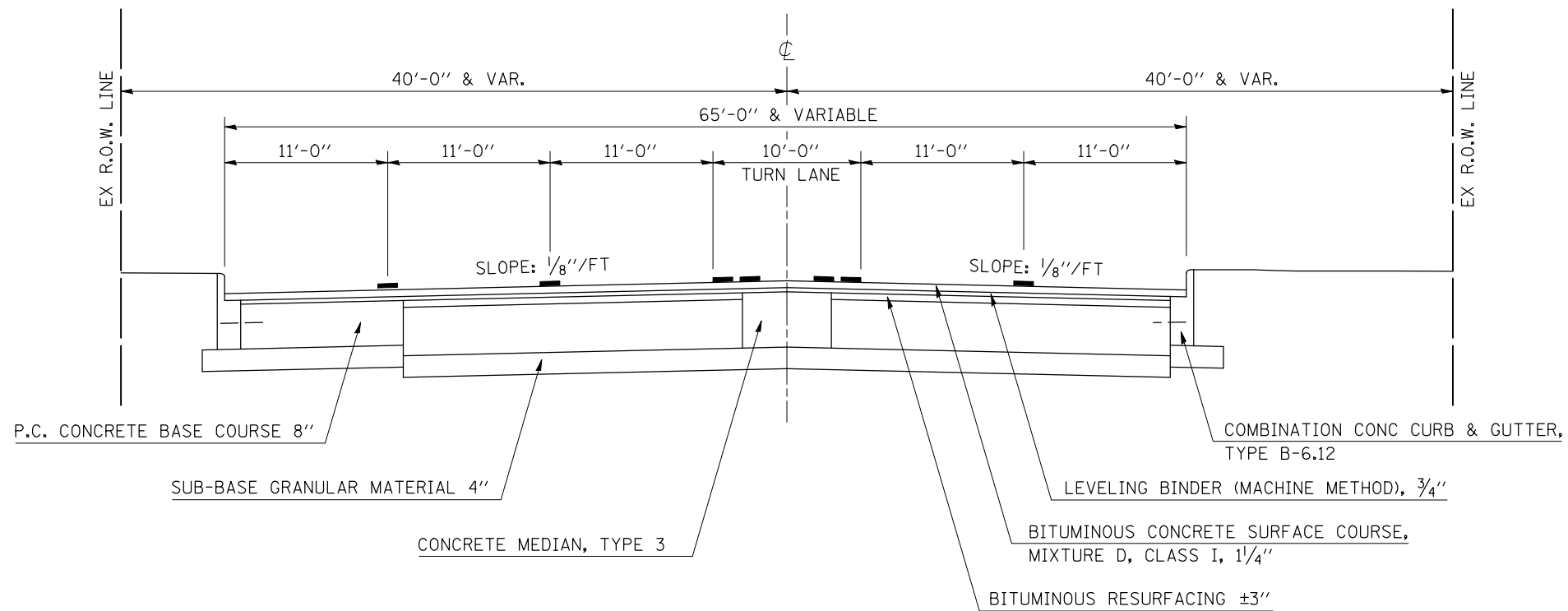

11 PROPOSED TYPICAL SECTION

STATION TO STATION
⑩ 2354+85.00 2356+00.00 ⑫

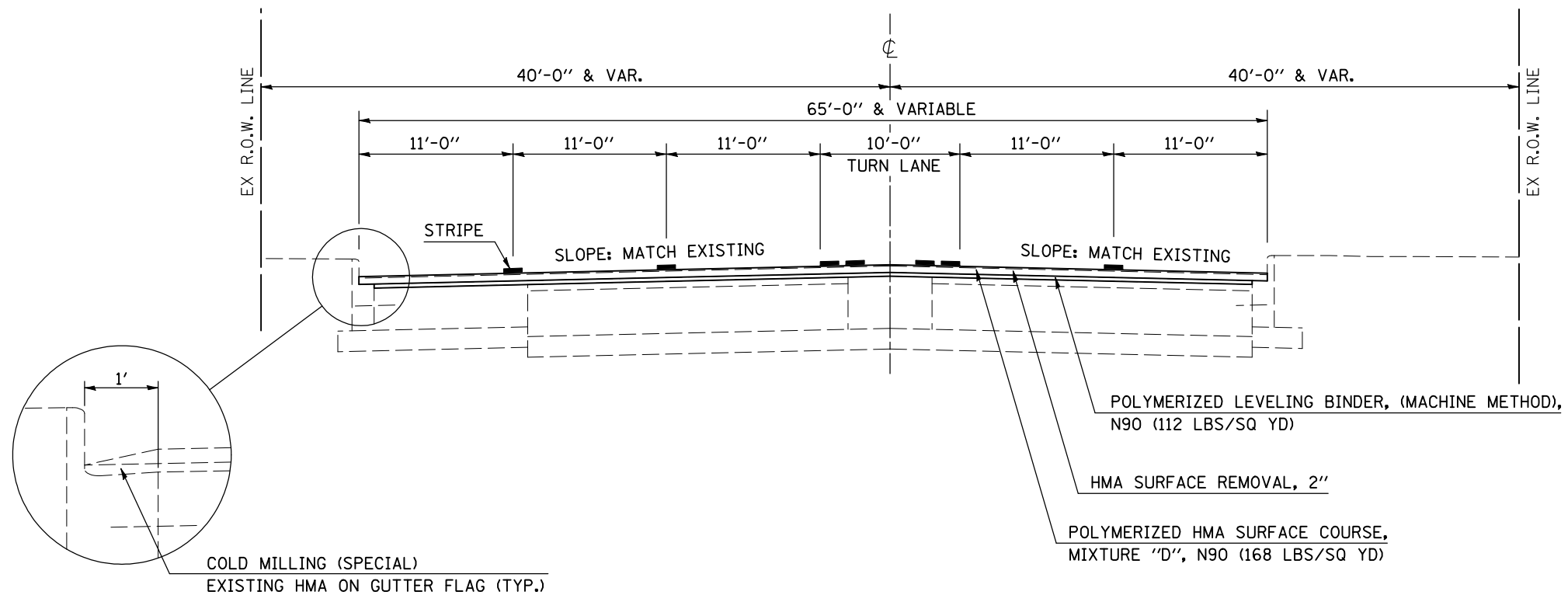

FILE NAME =	USER NAME = hoganbj	DESIGNED -	REVISED -
ct:\pw\work\PWIDOT\HOGANBJ\d0104446\D570117-shr-Typicals.dgn		DRAWN -	REVISED -
	PLOT SCALE = 40.0000' / IN.	CHECKED -	REVISED -
	PLOT DATE = 1/29/2010	DATE -	REVISED -

**STATE OF ILLINOIS
DEPARTMENT OF TRANSPORTATION**

EXISTING AND PROPOSED TYPICAL SECTION

SCALE: N/A SHEET NO. 11 OF 15 SHEETS STA. TO STA.

F.A.P. RTE.	SECTION	COUNTY	TOTAL SHEETS	SHEET NO.
709	(113)RS-1	CHAMPAIGN	65	17
FED. ROAD DIST. NO. ILLINOIS FED. AID PROJECT			CONTRACT NO. 70117	

EXISTING TYPICAL SECTION

STATION TO STATION
2356+00.00 2357+87.00

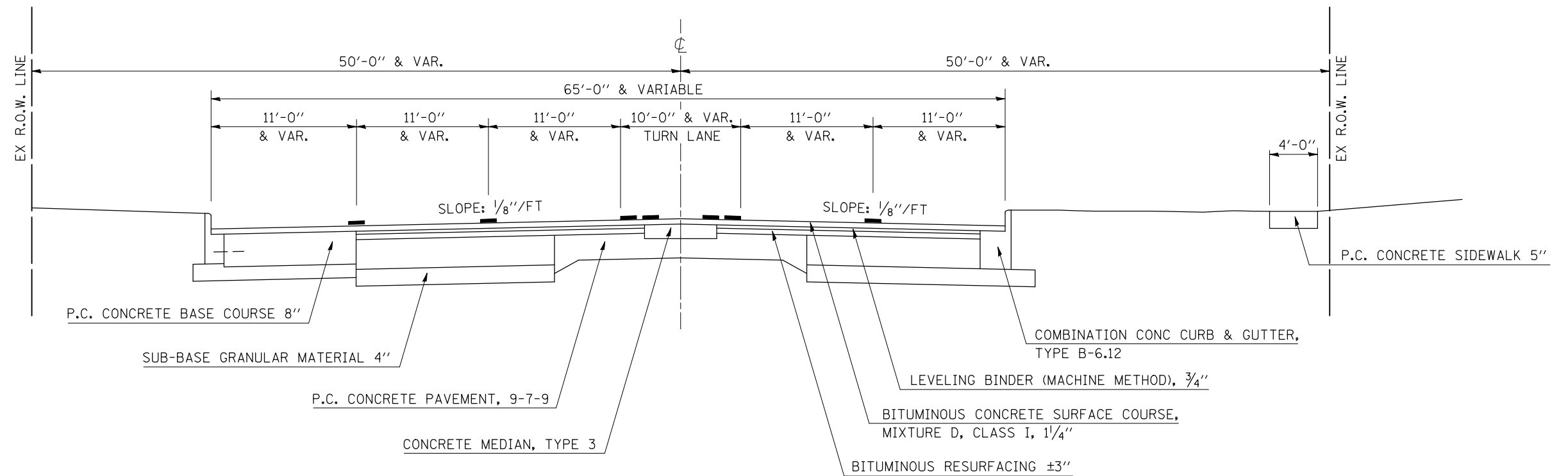

12 PROPOSED TYPICAL SECTION

STATION TO STATION
11 2356+00.00 2357+87.00 13

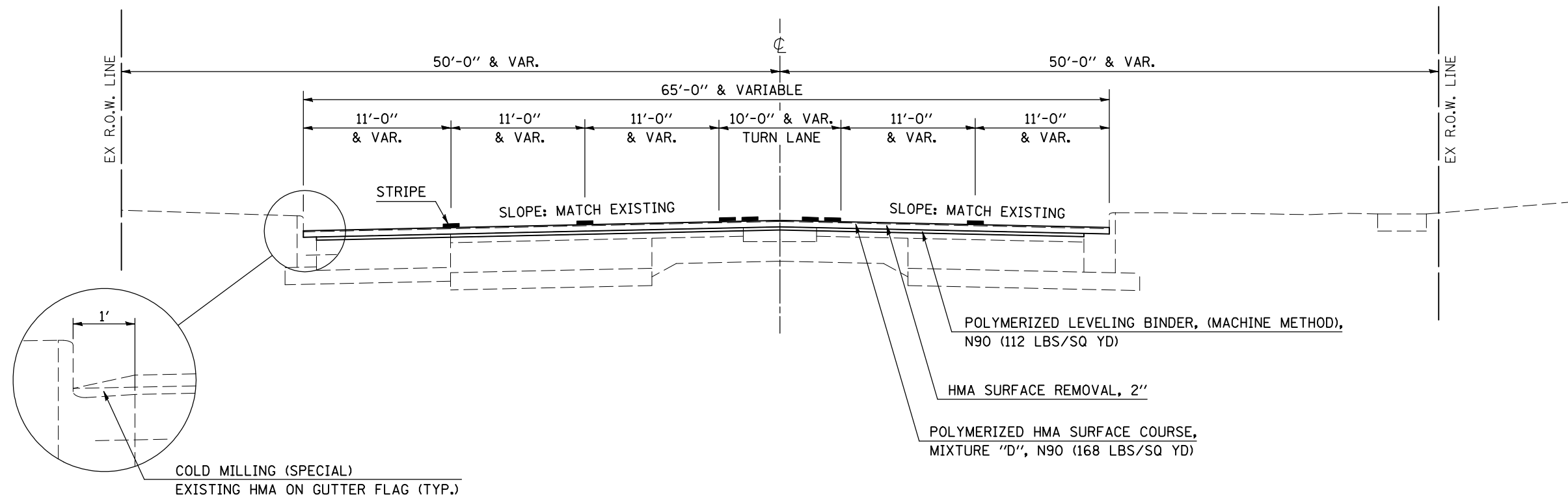

FILE NAME =	USER NAME = hoganbj	DESIGNED -	REVISED -
ct:\pwwork\pwidot\HOGANBJ\d0104446\0570117-sh-typical1.dgn		DRAWN -	REVISED -
		CHECKED -	REVISED -
		DATE -	REVISED -

**STATE OF ILLINOIS
DEPARTMENT OF TRANSPORTATION**

EXISTING AND PROPOSED TYPICAL SECTION

SCALE: N/A SHEET NO. 12 OF 15 SHEETS STA. TO STA.

F.A.P. RTE.	SECTION	COUNTY	TOTAL SHEETS	SHEET NO.
709	(113)RS-1	CHAMPAIGN	65	18
FED. ROAD DIST. NO. ILLINOIS FED. AID PROJECT			CONTRACT NO. 70117	

EXISTING TYPICAL SECTION

STATION TO STATION
2357+87.00 2359+89.00

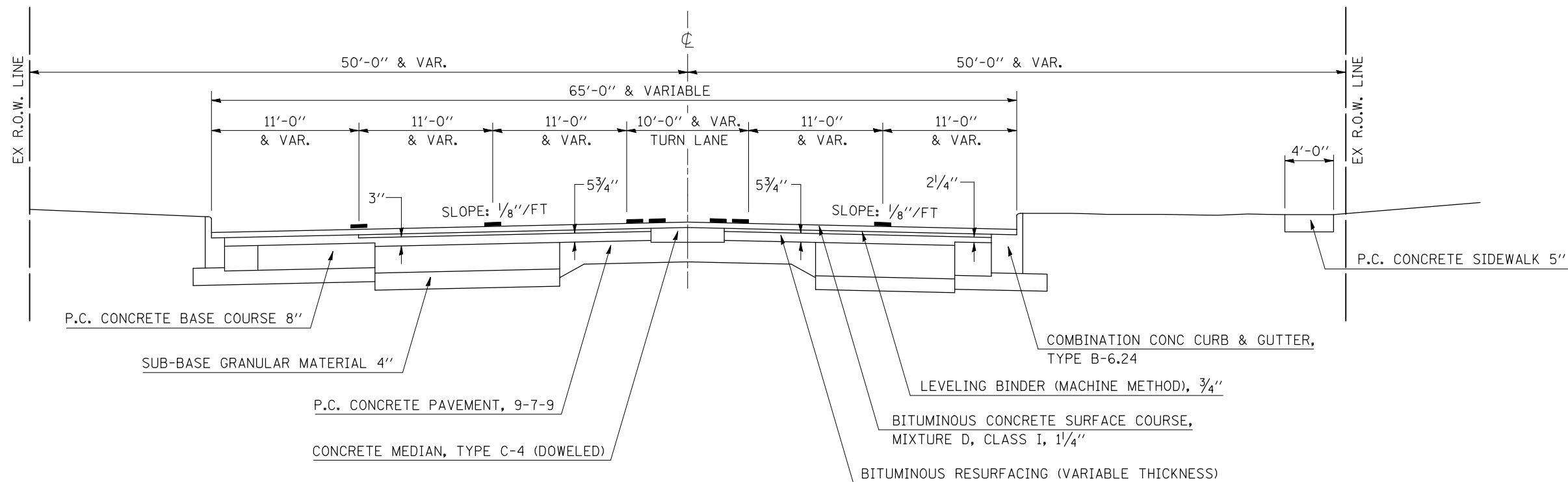

13 PROPOSED TYPICAL SECTION

STATION TO STATION
12 2357+87.00 2359+89.00 14

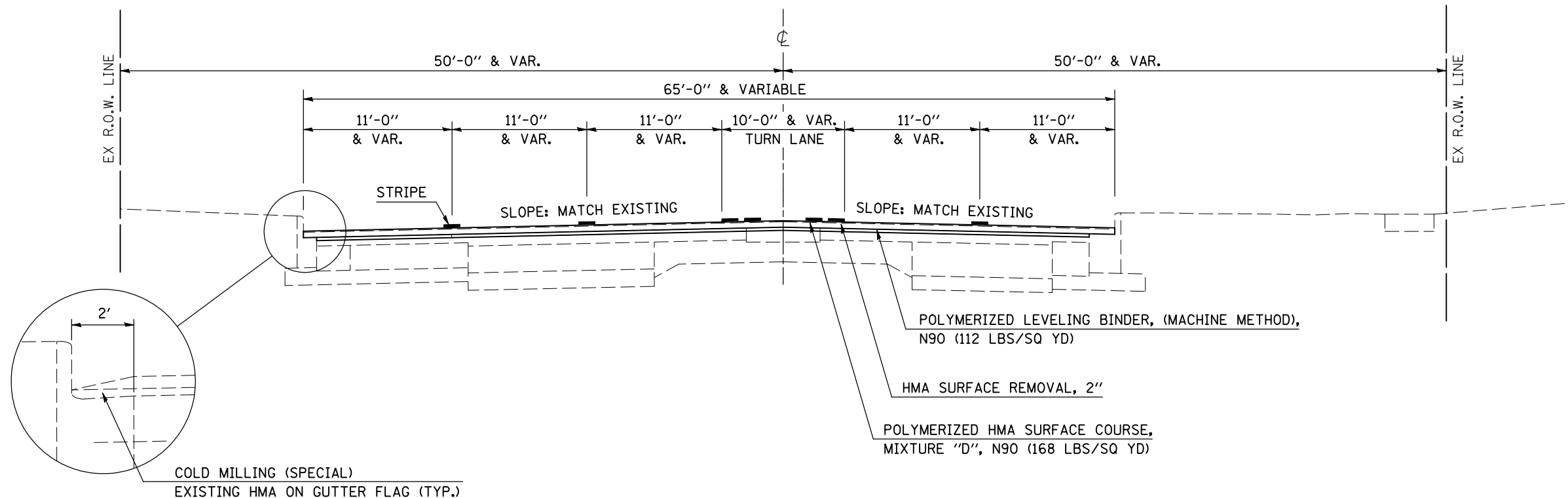

FILE NAME =	USER NAME = hoganbj	DESIGNED -	REVISED -
ct:\pw\work\PWIDOT\HOGANBJ\d0104446\D570	117-shr-Typicals.dgn	DRAWN -	REVISED -
PLOT SCALE = 40.0000 ' / IN.	CHECKED -	REVISED -	REVISED -
PLOT DATE = 1/29/2010	DATE -	REVISED -	REVISED -

**STATE OF ILLINOIS
DEPARTMENT OF TRANSPORTATION**

EXISTING AND PROPOSED TYPICAL SECTION

SCALE: N/A SHEET NO. 13 OF 15 SHEETS STA. TO STA.

F.A.P. RTE.	SECTION	COUNTY	TOTAL SHEETS	SHEET NO.
709	(113)RS-1	CHAMPAIGN	65	19
FED. ROAD DIST. NO. ILLINOIS FED. AID PROJECT			CONTRACT NO. 70117	

EXISTING TYPICAL SECTION

STATION TO STATION
 2359+89.00 2362+39.04 (BK)
 100+00.00 (AH) 100+59.00

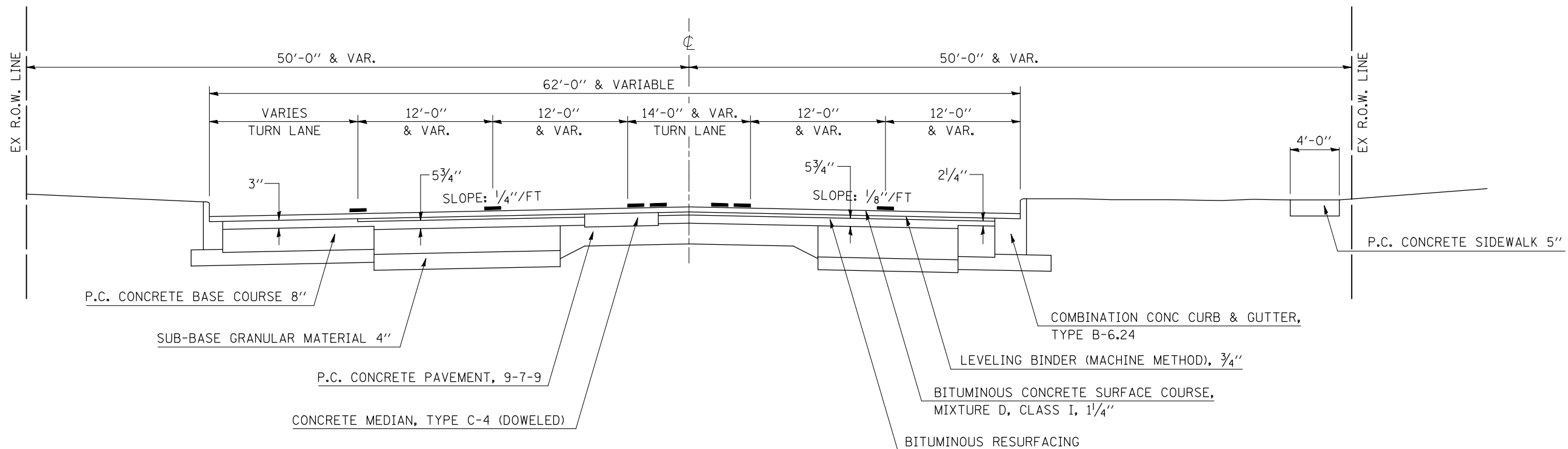

14 PROPOSED TYPICAL SECTION

STATION TO STATION
 2359+89.00 2362+39.04 (BK)
 100+00.00 (AH) 100+59.00 15

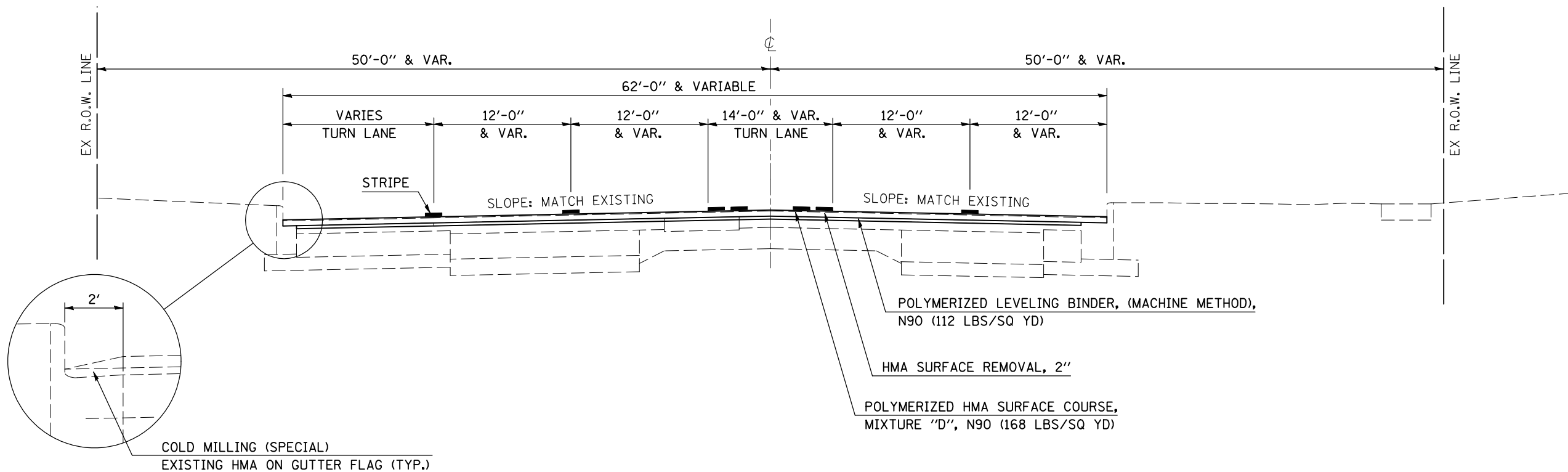

FILE NAME =	USER NAME = hoganbj	DESIGNED -	REVISED -
ct:\pwork\work\PWIDOT\HOGANBJ\d0104446\D574	117-shr-Typicals.dgn	DRAWN -	REVISED -
	PLOT SCALE = 40.0000 ' / IN.	CHECKED -	REVISED -
	PLOT DATE = 1/29/2010	DATE -	REVISED -

**STATE OF ILLINOIS
 DEPARTMENT OF TRANSPORTATION**

EXISTING AND PROPOSED TYPICAL SECTION

SCALE: N/A SHEET NO. 14 OF 15 SHEETS STA. TO STA.

F.A.P. RTE.	SECTION	COUNTY	TOTAL SHEETS	SHEET NO.
709	(113)RS-1	CHAMPAIGN	65	20
FED. ROAD DIST. NO. ILLINOIS FED. AID PROJECT			CONTRACT NO. 70117	

EXISTING TYPICAL SECTION

STATION TO STATION
100+59.00 105+64.00

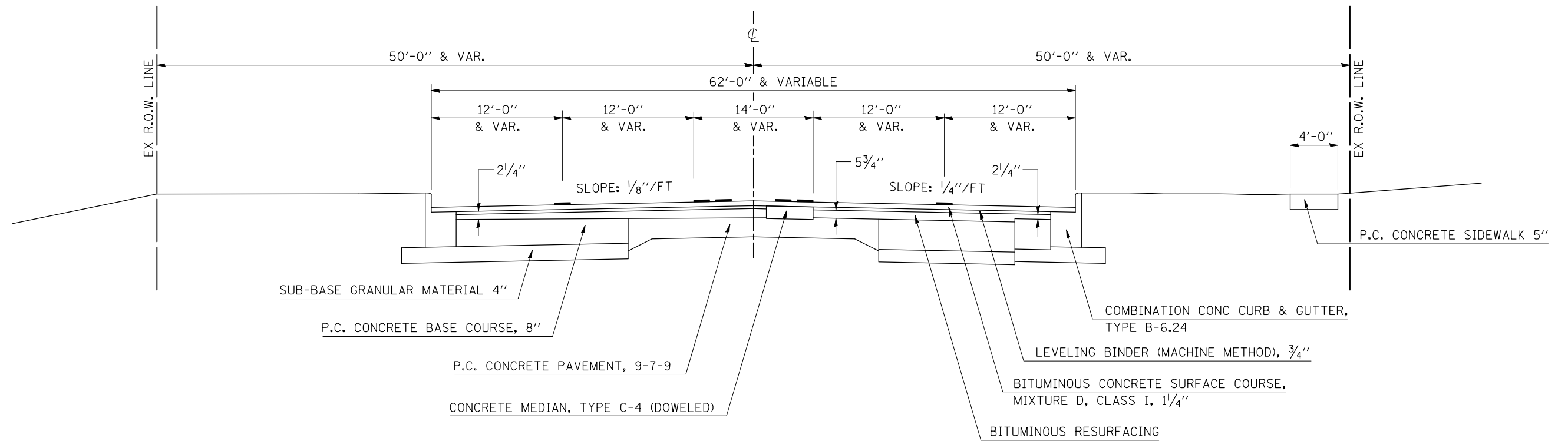

15 PROPOSED TYPICAL SECTION

STATION TO STATION
100+59.00 105+64.00

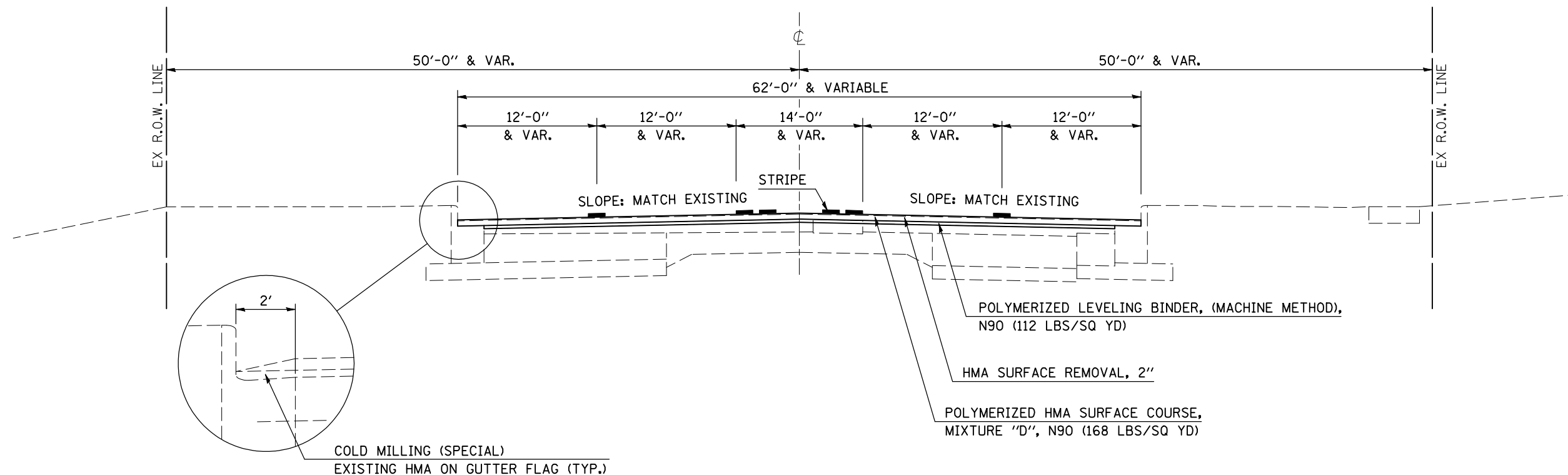

FILE NAME =	USER NAME = hoganbj	DESIGNED -	REVISED -
ct:\pwork\pwidot\HOGANBJ\d0104446\D570117-sh-typicals.dgn		DRAWN -	REVISED -
		CHECKED -	REVISED -
		DATE -	REVISED -

STATE OF ILLINOIS
DEPARTMENT OF TRANSPORTATION

EXISTING AND PROPOSED TYPICAL SECTION

SCALE: N/A SHEET NO. 15 OF 15 SHEETS STA. TO STA.

F.A.P. RTE.	SECTION	COUNTY	TOTAL SHEETS	SHEET NO.
709	(113)RS-1	CHAMPAIGN	65	21
FED. ROAD DIST. NO. ILLINOIS FED. AID PROJECT			CONTRACT NO. 70117	

SCHEDULES OF QUANTITIES

40600990 TEMPORARY RAMPS

STREET	LENGTH (FEET)	WIDTH (FEET)	AREA (SQ YD)
US 136 (2270+54.60 TO 2270+59.60)	5.0	52.0	28.9
US 136 (2290+14.00 TO 2290+19.00)	5.0	53.0	29.4
US 136 (2292+45.00 TO 2292+50.00)	5.0	58.0	32.2
US 136 (2303+16.62 TO 2303+23.32)	6.7	53.5	39.8
US 136 (2305+13.70 TO 2305+20.40)	6.7	53.0	39.5
US 136 (105+57.30 TO 105+64.00)	6.7	53.0	39.5
TANNER ST. (NORTH)	53.0	5.0	29.4
TANNER ST. (SOUTH)	48.0	5.0	26.7
MAPLEWOOD AVE. (NORTH)	88.0	5.0	48.9
MAPLEWOOD AVE. (SOUTH)	81.0	5.0	45.0
TOTAL =			359.3
ROUND TO:			360.0

60255500 MANHOLES TO BE ADJUSTED

STATION	OFFSET	# EACH
2278+00	24.0' RT	1.0
2278+35	32.0' RT	1.0
2282+61	24.0' RT	1.0
2287+26	11.0' RT	1.0
2295+40	70.0' LT	1.0
2296+06	21.0' RT	1.0
2296+14	23.0' LT	1.0
2296+44	20.0' LT	1.0
2297+68	27.0' LT	1.0
2297+88	17.0' RT	1.0
2298+68	26.0' LT	1.0
2299+80	14.0' RT	1.0
2299+80	14.0' LT	1.0
2300+10	14.0' RT	1.0
2300+10	14.0' LT	1.0
2300+37	19.0' LT	1.0
2302+00	16.4' RT	1.0
2308+65	28.0' RT	1.0
2308+89	17.0' RT	1.0
2308+90	26.0' LT	1.0
2319+01	26.0' LT	1.0
2353+19	13.0' RT	1.0
2354+66	28.0' LT	1.0
2357+56	13.0' RT	1.0
2357+91	23.0' RT	1.0
2358+08	20.0' LT	1.0
2358+39	28.0' LT	1.0
2359+14	23.0' RT	1.0
2359+15	28.0' LT	1.0
2360+86	20.0' LT	1.0
2360+94	23.0' RT	1.0
2361+19	20.0' LT	1.0
2362+14	28.0' LT	1.0
2362+22	13.0' RT	1.0
100+26	23.0' RT	1.0
100+34	28.0' LT	1.0
101+63	23.0' RT	1.0
102+50	24.0' LT	1.0
102+53	23.0' RT	1.0
103+97	24.0' LT	1.0
103+97	23.0' RT	1.0
TOTAL =		41.0

X0325808 PCC SURFACE REMOVAL, 2"

STA.	TO	STA.	LENGTH (FEET)	WIDTH (FEET)	AREA (SQ YD)
2347+40		2348+17	77.0	7.5	64.2
2348+17		2349+46	129.0	15.0	215.0
TOTAL =					279.2
ROUND TO:					280.0

X0301232 SURVEY MARKER VAULT

STA.	OFFSET	# EACH
2287+99.65	34.00' LT.	1.0
2331+46.00	2.30' LT.	1.0
100+59.00	1.60' LT.	1.0
TOTAL =		3.0

XZ193400 SURVEY MARKER, TYPE 2, SPECIAL

STA.	OFFSET	# EACH
2283+71.41	CL	1.0
2298+12.86 (BK.) = 2298+14.21 (AH.)	CL	1.0
TOTAL =		2.0

SCHEDULES OF QUANTITIES

INCIDENTAL HMA (SHEET 1 OF 5)

STATION	LT. OR RT.	TYPE	W1 (feet)	W2 (feet)	L (feet)	M1 (feet)	AREA (SY)	40600982 HMA SURFACE REMOVAL, BUTT JOINT	40600985 PCC SURFACE REMOVAL, BUTT JOINT	40800010 BITUMINOUS MATERIALS (PRIME COAT)	40800030 AGGREGATE (PRIME COAT)	40800050 INCIDENTAL HMA SURFACING
2270+54.60	LT.&RT.	Mainline				30	173.3		173.3			
2271+09.12	RT.	P.E.	31	19	5	3	13.9		6.8	1.4	0.0	1.6
2271+18.69	LT.	P.E.	45	24	5	3	19.2		8.3	1.9	0.0	2.1
2271+35.54	RT.	P.E.	31	19	5	3	13.9		6.8	1.4	0.0	1.6
2271+92.90	LT.	P.E.	41	23	5	3	17.8		8.0	1.8	0.0	2.0
2272+30.73	RT.	P.E.	31	19	5	3	13.9		6.8	1.4	0.0	1.6
2272+71.20	LT.	P.E.	35	17	5	3	14.4		6.2	1.4	0.0	1.6
2273+01.53	RT.	P.E.	41	23	5	3	17.8		8.3	1.8	0.0	2.0
2273+46.95	LT.	P.E.	38	18	5	3	15.6		6.3	1.6	0.0	1.7
2273+97.85	LT.	P.E.	40	23	5	3	17.5		7.7	1.8	0.0	2.0
2274+30.10	RT.	P.E.	31	15	5	3	12.8		5.7	1.3	0.0	1.4
2274+71.84	RT.	P.E.	31	19	5	3	13.9		6.8	1.4	0.0	1.6
2275+47.79	LT.	P.E.	38	17	5	3	15.3		6.5	1.5	0.0	1.7
2275+58.95	RT.	P.E.	39	22	5	3	16.9		8.2	1.7	0.0	1.9
2276+37.70	RT.	P.E.	38	23	5	3	16.9		8.3	1.7	0.0	1.9
2277+09.10	LT.	P.E.	38	17	5	3	15.3		6.5	1.5	0.0	1.7
2278+18.01	RT.	James	91	26	41	30	266.5		128.3	26.7	0.4	29.8
2279+26.82	LT.	P.E.	34	17	5	3	14.2		6.2	1.4	0.0	1.6
2279+46.91	RT.	P.E.	34	17	5	3	14.2		6.5	1.4	0.0	1.6
2279+58.91	RT.	P.E.	34	17	5	3	14.2		6.5	1.4	0.0	1.6
2280+00	RT.	P.E.	28	15	5	3	11.9		6.2	1.2	0.0	1.3
2280+17.22	RT.	P.E.	26	16	5	3	11.7		6.3	1.2	0.0	1.3
2281+00.59	LT.	P.E.	34	19	5	3	14.7		7.0	1.5	0.0	1.6
2281+11.96	RT.	P.E.	33	20	5	3	14.7		7.3	1.5	0.0	1.6
2281+37.40	RT.	P.E.	34	23	5	3	15.8		8.2	1.6	0.0	1.8
2282+71.37	RT.	P.E.	48	30	5	3	21.7		10.8	2.2	0.0	2.4
2282+78.49	LT.	P.E.	34	19	5	3	14.7		7.0	1.5	0.0	1.6
2283+47.44	RT.	P.E.	32	17	5	3	13.6		6.5	1.4	0.0	1.5
2284+76.68	RT.	P.E.	42	25	5	3	18.6		9.0	1.9	0.0	2.1
2285+28.99	LT.	P.E.	34	17	5	3	14.2		6.5	1.4	0.0	1.6
2285+73.01	LT.	P.E.	35	20	5	3	15.3		7.3	1.5	0.0	1.7
2286+44.74	LT.	P.E.	40	22	5	3	17.2		7.7	1.7	0.0	1.9
2287+99.65	LT.	Myers	102	49	15	9	125.8		58.0	12.6	0.2	14.1
2287+99.65	RT.	Mary Alice	97	26	50	30	341.7		103.3	34.2	0.5	38.3
2290+19.00	LT.&RT.	Mainline				30	176.7		176.7			
2292+45.00	LT.&RT.	Mainline				30	196.7		196.7			
2294+40.54	RT.	C.E.	53	36	5	3	24.7		13.2	2.5	0.0	2.8
2295+55.51	LT.	Tanner	227	53	110	30	1711.1		195.0	171.1	2.6	0.0
2295+55.51	RT.	Tanner	224	48	146	30	2206.2		163.3	220.6	3.3	0.0
2296+77	LT.	P.E.	34	17	5	3	14.2		6.5	1.4	0.0	3.2
2297+28	RT.	P.E.	42	28	5	5	19.4	19.4		1.9	0.0	1.6
2297+30	LT.	P.E.	45	22	5	5	18.6	18.6		1.9	0.0	1.6
2297+96	LT.	P.E.	42	17	5	5	16.4	16.4		1.6	0.0	1.4
SHEET 1 SUBTOTALS							5579.7	54.4	1430.5	520.6	7.8	144.4

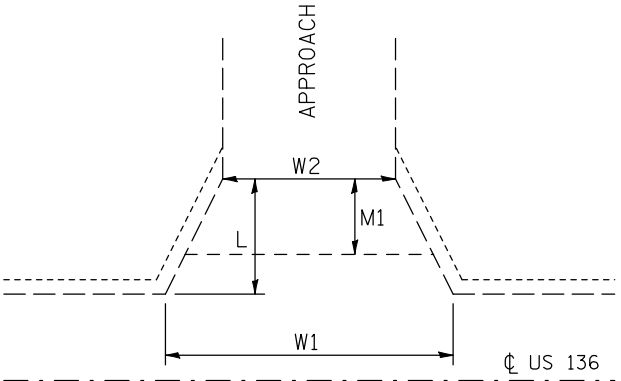

W1 = FRONT WIDTH OF HMA APPROACH
W2 = BACK WIDTH OF HMA APPROACH
L = DISTANCE FROM MAINLINE FACE OF CURB TO LIMITS OF HMA APPROACH
M1 = PROPOSED LENGTH OF PCC OR HMA BUTT JOINT

* BUTT JOINT SHALL BE MILLED TO PROVIDE 1/2" DEPTH AT W2 AND A MINIMUM OF 1" HMA DEPTH AT ALL OTHER LOCATIONS. A STRINGLINE SHALL BE USED TO ASSURE THIS REQUIREMENT

SCHEDULES OF QUANTITIES

INCIDENTAL HMA (SHEET 2 OF 5)

STATION	LT. OR RT.	TYPE	W1 (feet)	W2 (feet)	L (feet)	M1 (feet)	AREA (SY)	40600982 HMA SURFACE REMOVAL, BUTT JOINT	40600985 PCC SURFACE REMOVAL, BUTT JOINT	40800010 BITUMINOUS MATERIALS (PRIME COAT)	40800030 AGGREGATE (PRIME COAT)	40800050 INCIDENTAL HMA SURFACING
2298+47	RT.	P.E.	36	17	5	5	14.7	14.7		1.5	0.0	1.2
2298+89	RT.	P.E.	34	15	5	5	13.6	13.6		1.4	0.0	1.2
2298+98	LT.	P.E.	28	17	5	5	12.5	12.5		1.3	0.0	1.2
2299+90.79	LT.	Garrard	120	58	25	25	247.2	247.2		24.7	0.4	20.8
2299+90.79	RT.	Garrard	106	47	22	22	187.0	187.0		18.7	0.3	15.7
2301+70	LT.	C.E.	50	36	5	5	23.9	23.9		2.4	0.0	2.0
2301+76	RT.	P.E.	35	21	5	5	15.6	15.6		1.6	0.0	1.3
2302+25	LT.	C.E.	50	36	5	5	23.9	23.9		2.4	0.0	2.0
2302+31	RT.	C.E.	45	26	5	5	19.7	19.7		2.0	0.0	1.7
2305+55	LT.	C.E.	55	41	5	5	26.7	26.7		2.7	0.0	2.2
2305+57.5	RT.	C.E.	55	41	5	5	26.7	26.7		2.7	0.0	2.2
2306+07.5	LT.	C.E.	40	27	5	5	18.6	18.6		1.9	0.0	1.6
2306+19	RT.	Alley	40	23	5	5	17.5	17.5		1.8	0.0	1.5
2307+21	RT.	C.E.	51	37	5	5	24.4	24.4		2.4	0.0	2.1
2307+61	RT.	C.E.	40	27	5	5	18.6	18.6		1.9	0.0	1.6
2308+12	RT.	C.E.	40	27	5	5	18.6	18.6		1.9	0.0	1.6
2309+00	LT.	Marshall	80	27	29	29	172.4	172.4		17.2	0.3	14.5
2309+00	RT.	Marshall	73	31	15	15	86.7	86.7		8.7	0.1	7.3
2309+60	RT.	C.E.	40	27	5	5	18.6	18.6		1.9	0.0	1.6
2309+95	RT.	P.E.	25	12	5	5	10.3	10.3		1.0	0.0	0.9
2310+91	RT.	C.E.	40	29	5	5	19.2	19.2		1.9	0.0	1.6
2310+96	LT.	P.E.	40	23	5	5	17.5	17.5		1.8	0.0	1.5
2311+48	LT.	C.E.	27	14	5	5	11.4	11.4		1.1	0.0	1.0
2311+62	RT.	C.E.	28	12	5	5	11.1	11.1		1.1	0.0	0.9
2312+24	RT.	C.E.	28	12	5	5	11.1	11.1		1.1	0.0	0.9
2312+35	LT.	C.E.	32	20	5	5	14.4	14.4		1.4	0.0	1.2
2312+76	LT.	C.E.	25	14	5	5	10.8	10.8		1.1	0.0	0.9
2313+81.59	LT.	Fredrick	88	40	15	15	106.7	106.7		10.7	0.2	9.0
2313+81.59	RT.	Fredrick	96	42	13	13	99.7	99.7		10.0	0.1	8.4
2314+86	RT.	C.E.	32	16	5	5	13.3	13.3		1.3	0.0	1.1
2315+51	RT.	C.E.	40	26	5	5	18.3	18.3		1.8	0.0	1.5
2315+88	RT.	C.E.	35	14	5	5	13.6	13.6		1.4	0.0	1.1
2316+30	RT.	C.E.	35	16	5	5	14.2	14.2		1.4	0.0	1.2
2317+08	RT.	C.E.	28	23	5	5	14.2	14.2		1.4	0.0	1.2
2318+09	RT.	C.E.	44	26	5	5	19.4	19.4		1.9	0.0	1.6
2318+67.20	LT.	Sheldon	88	53	9	9	70.5	70.5		7.1	0.1	5.9
2319+14	RT.	P.E.	35	16	5	5	14.2	14.2		1.4	0.0	1.2
SHEET 2 SUBTOTALS							1476.8	1476.8	0.0	147.7	2.2	124.4

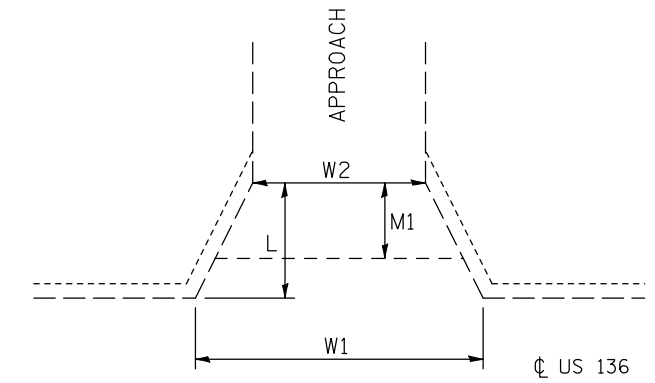

W1 = FRONT WIDTH OF HMA APPROACH
 W2 = BACK WIDTH OF HMA APPROACH
 L = DISTANCE FROM MAINLINE FACE OF CURB TO LIMITS OF HMA APPROACH
 M1 = PROPOSED LENGTH OF PCC OR HMA BUTT JOINT

* BUTT JOINT SHALL BE MILLED TO PROVIDE 1/2" DEPTH AT W2 AND A MINIMUM OF 1" HMA DEPTH AT ALL OTHER LOCATIONS. A STRINGLINE SHALL BE USED TO ASSURE THIS REQUIREMENT

SCHEDULES OF QUANTITIES

INCIDENTAL HMA (SHEET 3 OF 5)

STATION	LT. OR RT.	TYPE	W1 (feet)	W2 (feet)	L (feet)	M1 (feet)	AREA (SY)	40600982 HMA SURFACE REMOVAL. BUTT JOINT	40600985 PCC SURFACE REMOVAL. BUTT JOINT	40800010 BITUMINOUS MATERIALS (PRIME COAT)	40800030 AGGREGATE (PRIME COAT)	40800050 INCIDENTAL HMA SURFACING	
2319+72	RT.	C.E.	28	16	5	5	12.2	12.2		1.2	0.0	1.0	
2320+59.5	LT.	C.E.	61	42	5	5	28.6	28.6		2.9	0.0	2.4	
2320+79	RT.	P.E.	26	14	5	5	11.1	11.1		1.1	0.0	0.9	
2321+52	RT.	C.E.	30	12	5	5	11.7	11.7		1.2	0.0	1.0	
2322+13	RT.	C.E.	30	14	5	5	12.2	12.2		1.2	0.0	1.0	
2322+49.2	LT.	C.E.	58	35	5	5	25.8	25.8		2.6	0.0	2.2	
2322+65	RT.	C.E.	23	14	5	5	10.3	10.3		1.0	0.0	0.9	
2322+85	RT.	C.E.	26	14	5	5	11.1	11.1		1.1	0.0	0.9	
2323+33	RT.	P.E.	23	12	5	5	9.7	9.7		1.0	0.0	0.8	
2323+68	LT.	C.E.	61	35	5	5	26.7	26.7		2.7	0.0	2.2	
2324+11	RT.	Lincoln	54	21	15	15	62.5	62.5		6.3	0.1	5.3	
2324+72	RT.	P.E.	25	14	5	5	10.8	10.8		1.1	0.0	0.9	
2324+92	RT.	P.E.	26	16	5	5	11.7	11.7		1.2	0.0	1.0	
2325+48	RT.	Alley	40	25	5	5	18.1	18.1		1.8	0.0	1.5	
2326+10	RT.	C.E.	46	28	5	5	20.6	20.6		2.1	0.0	1.7	
2326+63	RT.	C.E.	49	35	5	5	23.3	23.3		2.3	0.0	2.0	
2327+22	RT.	Steffler	70	26	30	30	160.0	160.0		16.0	0.2	13.4	
2328+79	RT.	Alley	39	21	5	5	16.7	16.7		1.7	0.0	1.4	
2329+40	RT.	C.E.	81	60	5	5	39.2	39.2		3.9	0.1	3.3	
2330+74	LT.	Chanute	88	37	20	20	138.9	138.9		13.9	0.2	11.7	
2330+74	RT.	Chanute	88	42	18	18	130.0	130.0		13.0	0.2	10.9	
2332+25	RT.	C.E.	61	47	5	5	30.0	30.0		3.0	0.0	2.5	
2332+56	RT.	C.E.	44	25	5	5	19.2	19.2		1.9	0.0	1.6	
2333+30	RT.	C.E.	37	23	5	5	16.7	16.7		1.7	0.0	1.4	
2333+59.4	LT.	P.E.	35	18	5	5	14.7	14.7		1.5	0.0	1.2	
2334+80	RT.	P.E.	28	12	5	5	11.1	11.1		1.1	0.0	0.9	
2335+81.6	RT.	Charles	47	23	18	18	70.0	70.0		7.0	0.1	5.9	
2335+90.9	LT.	Congress	72	39	11	11	67.8	67.8		6.8	0.1	5.7	
2336+35.2	LT.	P.E.	28	16	5	5	12.2	12.2		1.2	0.0	1.0	
2336+75	RT.	Elaine	47	23	16	16	62.2	62.2		6.2	0.1	5.2	
2336+83	LT.	P.E.	32	16	5	5	13.3	13.3		1.3	0.0	1.1	
2337+75	RT.	Charles	47	23	16	16	62.2	62.2		6.2	0.1	5.2	
2337+85	LT.	P.E.	21	10	5	5	8.6	8.6		0.9	0.0	0.7	
2338+69.6	LT.	P.E.	26	16	5	5	11.7	11.7		1.2	0.0	1.0	
2339+17	RT.	P.E.	32	14	5	5	12.8	12.8		1.3	0.0	1.1	
2339+86.5	RT.	P.E.	30	14	5	5	12.2	12.2		1.2	0.0	1.0	
2340+47	RT.	P.E.	30	14	5	5	12.2	12.2		1.2	0.0	1.0	
2340+97	LT.	Sangamon	79	35	15	15	95.0	95.0		9.5	0.1	8.0	
2341+02.9	RT.	P.E.	30	14	5	5	12.2	12.2		1.2	0.0	1.0	
SHEET 3 SUBTOTALS								1335.3	1335.3	0.0	133.5	2.0	111.9

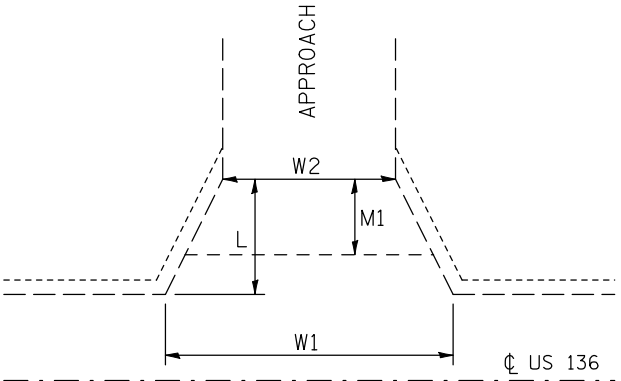

W1 = FRONT WIDTH OF HMA APPROACH
W2 = BACK WIDTH OF HMA APPROACH
L = DISTANCE FROM MAINLINE FACE OF CURB TO LIMITS OF HMA APPROACH
M1 = PROPOSED LENGTH OF PCC OR HMA BUTT JOINT

* BUTT JOINT SHALL BE MILLED TO PROVIDE 1/2" DEPTH AT W2 AND A MINIMUM OF 1" HMA DEPTH AT ALL OTHER LOCATIONS. A STRINGLINE SHALL BE USED TO ASSURE THIS REQUIREMENT

SCHEDULES OF QUANTITIES

INCIDENTAL HMA (SHEET 4 OF 5)

STATION	LT. OR RT.	TYPE	W1 (feet)	W2 (feet)	L (feet)	M1 (feet)	AREA (SY)	40600982 HMA SURFACE REMOVAL BUTT JOINT	40600985 PCC SURFACE REMOVAL BUTT JOINT	40800010 BITUMINOUS MATERIALS (PRIME COAT)	40800030 AGGREGATE (PRIME COAT)	40800050 INCIDENTAL HMA SURFACING
2341+58	RT.	P.E.	30	14	5	5	12.2	12.2		1.2	0.0	1.0
2341+85.9	LT.	P.E.	33	16	5	5	13.6	13.6		1.4	0.0	1.1
2342+09.4	RT.	P.E.	30	14	5	5	12.2	12.2		1.2	0.0	1.0
2342+77.8	LT.	P.E.	30	16	5	5	12.8	12.8		1.3	0.0	1.1
2342+87.4	RT.	C.E.	58	40	5	5	27.2	27.2		2.7	0.0	2.3
2344+02	RT.	C.E.	51	35	5	5	23.9	23.9		2.4	0.0	2.0
2344+08	LT.	C.E.	56	37	5	5	25.8	25.8		2.6	0.0	2.2
2344+90	RT.	Prairieview	89	47	10	10	75.6	75.6		7.6	0.1	6.3
2344+97.5	LT.	C.E.	61	37	5	5	27.2	27.2		2.7	0.0	2.3
2345+60	LT.	C.E.	56	39	5	5	26.4	26.4		2.6	0.0	2.2
2346+06	RT.	P.E.	30	14	5	5	12.2	12.2		1.2	0.0	1.0
2346+19	LT.	C.E.	56	39	5	5	26.4	26.4		2.6	0.0	2.2
2346+71	LT.	C.E.	47	26	5	5	20.3	20.3		2.0	0.0	1.7
2346+72	RT.	P.E.	18	12	5	5	8.3	8.3		0.8	0.0	0.7
2347+30	RT.	P.E.	18	12	5	5	8.3	8.3		0.8	0.0	0.7
2347+41.4	LT.	C.E.	49	23	5	5	20.0	20.0		2.0	0.0	1.7
2347+99	RT.	P.E.	21	9	5	5	8.3	8.3		0.8	0.0	0.7
2348+57	RT.	P.E.	18	9	5	5	7.5	7.5		0.8	0.0	0.6
2349+00	LT.	Grove	184	144	7	4	127.6		65.6	12.8	0.2	10.7
2349+22	RT.	P.E.	21	9	5	5	8.3	8.3		0.8	0.0	0.7
2349+85.5	RT.	P.E.	18	9	5	5	7.5	7.5		0.8	0.0	0.6
2350+44.2	RT.	P.E.	23	12	5	5	9.7	9.7		1.0	0.0	0.8
2351+55	RT.	P.E.	23	11	5	5	9.4	9.4		0.9	0.0	0.8
2352+12	RT.	P.E.	18	9	5	5	7.5	7.5		0.8	0.0	0.6
2352+38	LT.	C.E.	37	30	5	5	18.6	18.6		1.9	0.0	1.6
2352+77.1	RT.	P.E.	18	9	5	5	7.5	7.5		0.8	0.0	0.6
2353+16	RT.	C.E.	21	16	5	5	10.3	10.3		1.0	0.0	0.9
2354+03	RT.	P.E.	23	14	5	5	10.3	10.3		1.0	0.0	0.9
2354+69.1	RT.	P.E.	21	9	5	5	8.3	8.3		0.8	0.0	0.7
2355+10.6	LT.	C.E.	44	26	5	5	19.4	19.4		1.9	0.0	1.6
2355+30	RT.	P.E.	21	14	5	5	9.7	9.7		1.0	0.0	0.8
2355+44.6	LT.	C.E.	40	25	5	5	18.1	18.1		1.8	0.0	1.5
2355+92.5	RT.	P.E.	18	14	5	5	8.9	8.9		0.9	0.0	0.7
2357+12.3	RT.	Arcadia	91	35	30	30	210.0	210.0		21.0	0.3	17.6
2358+26.2	RT.	P.E.	26	14	5	5	11.1	11.1		1.1	0.0	0.9
2358+35.4	LT.	C.E.	53	30	5	5	23.1	23.1		2.3	0.0	1.9
2358+64.6	LT.	C.E.	53	30	5	5	23.1	23.1		2.3	0.0	1.9
2358+82.8	RT.	P.E.	26	12	5	5	10.6	10.6		1.1	0.0	0.9
2359+32.6	RT.	P.E.	28	14	5	5	11.7	11.7		1.2	0.0	1.0
SHEET 4 SUBTOTALS							938.9	811.3	65.6	93.9	1.4	78.5

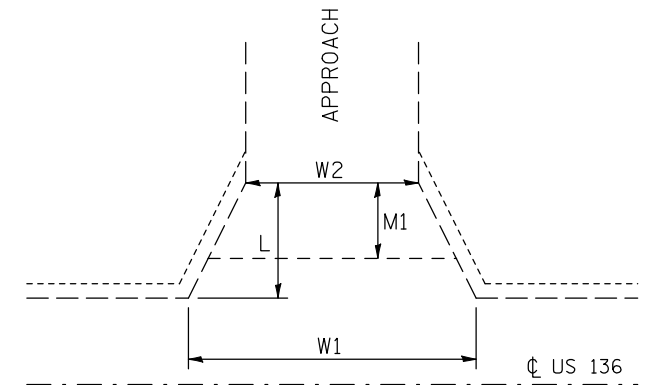

W1 = FRONT WIDTH OF HMA APPROACH
W2 = BACK WIDTH OF HMA APPROACH
L = DISTANCE FROM MAINLINE FACE OF CURB TO LIMITS OF HMA APPROACH
M1 = PROPOSED LENGTH OF PCC OR HMA BUTT JOINT

* BUTT JOINT SHALL BE MILLED TO PROVIDE 1/2" DEPTH AT W2 AND A MINIMUM OF 1" HMA DEPTH AT ALL OTHER LOCATIONS. A STRINGLINE SHALL BE USED TO ASSURE THIS REQUIREMENT

SCHEDULES OF QUANTITIES

INCIDENTAL HMA (SHEET 5 OF 5)

STATION	LT. OR RT.	TYPE	W1 (feet)	W2 (feet)	L (feet)	M1 (feet)	AREA (SY)	40600982 HMA SURFACE REMOVAL, BUTT JOINT	40600985 PCC SURFACE REMOVAL, BUTT JOINT	40800010 BITUMINOUS MATERIALS (PRIME COAT)	40800030 AGGREGATE (PRIME COAT)	40800050 INCIDENTAL HMA SURFACING
2359+83.5	RT.	P.E.	30	14	5	5	12.2	12.2		1.2	0.0	1.0
2360+36	RT.	P.E.	26	16	5	5	11.7	11.7		1.2	0.0	1.0
2360+90	LT.	C.E.	70	40	5	3	30.6		14.8	3.1	0.0	2.6
2361+13	RT.	C.E.	46	37	5	5	23.1	23.1		2.3	0.0	1.9
2361+83	LT.	C.E.	70	46	5	3	32.2		16.7	3.2	0.0	2.7
100+59	LT.	Maplewood	140	88	15	15	190.0	190.0		19.0	0.3	16.0
100+59	RT.	Maplewood	140	81	15	15	184.2	184.2		18.4	0.3	15.5
101+72	RT.	C.E.	53	33	5	5	23.9	23.9		2.4	0.0	2.0
102+23	RT.	C.E.	53	33	5	5	23.9	23.9		2.4	0.0	2.0
103+33	RT.	C.E.	46	37	5	5	23.1	23.1		2.3	0.0	1.9
SHEET 5 SUBTOTALS							554.7	492.1	31.5	55.5	0.8	46.6

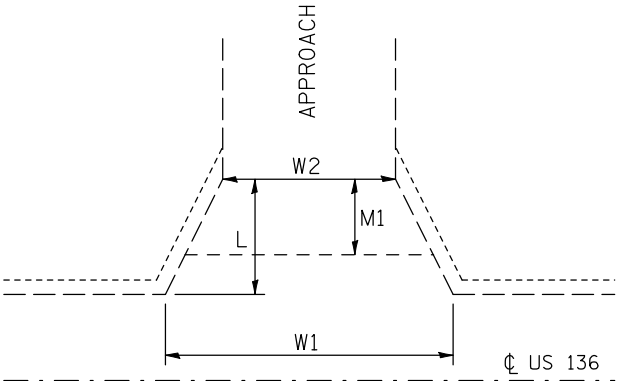

SHEET 1 SUBTOTALS	5579.7	54.4	1430.5	520.6	7.8	144.4
SHEET 2 SUBTOTALS	1476.8	1476.8	0.0	147.7	2.2	124.4
SHEET 3 SUBTOTALS	1335.3	1335.3	0.0	133.5	2.0	111.9
SHEET 4 SUBTOTALS	938.9	811.3	65.6	93.9	1.4	78.5
SHEET 5 SUBTOTALS	554.7	492.1	31.5	55.5	0.8	46.6
TOTAL=	9885.5	4169.9	1527.6	951.2	14.3	505.8
ROUND TO	NA	4175.0	1530.0	955.0	15.0	510.0

W1 = FRONT WIDTH OF HMA APPROACH
 W2 = BACK WIDTH OF HMA APPROACH
 L = DISTANCE FROM MAINLINE FACE OF CURB TO LIMITS OF HMA APPROACH
 M1 = PROPOSED LENGTH OF PCC OR HMA BUTT JOINT

* BUTT JOINT SHALL BE MILLED TO PROVIDE 1/2" DEPTH AT W2 AND A MINIMUM OF 1" HMA DEPTH AT ALL OTHER LOCATIONS. A STRINGLINE SHALL BE USED TO ASSURE THIS REQUIREMENT

SCHEDULES OF QUANTITIES

CLASS D PATCHES 8"

STATION	DIRECTION	LANE	LENGTH	WIDTH	PATCH AREA			
					TYPE I	TYPE II	TYPE III	TYPE IV
					8.0" 44201737 (sq. yd)	8.0" 44201741 (sq. yd)	8.0" 44201745 (sq. yd)	8.0" 44201747 (sq. yd)
2355+17	WB	RT T	10	10	0.0	11.1	0.0	0.0
2357+40	WB	RT T	6	10	0.0	6.7	0.0	0.0
ROUNDED GRAND TOTALS:					0.0	18.0	0.0	0.0

CLASS D PATCHES 14"

STATION	DIRECTION	LANE	LENGTH	WIDTH	PATCH AREA			
					TYPE I	TYPE II	TYPE III	TYPE IV
					14.0" 44201811 (sq. yd)	14.0" 44201815 (sq. yd)	14.0" 44201819 (sq. yd)	14.0" 44201821 (sq. yd)
100+11	EB	DL	6	10	0.0	6.7	0.0	0.0
100+11	EB	PL	6	12	0.0	8.0	0.0	0.0
ROUNDED GRAND TOTALS:					0.0	15.0	0.0	0.0

SCHEDULES OF QUANTITIES

CLASS D PATCHES 10" (SHEET 1 OF 2)

STATION	DIRECTION	LANE	LENGTH	WIDTH	PATCHAREA			
					TYPE I	TYPE II	TYPE III	TYPE IV
					10.0" 44201761 (sq. yd)	10.0" 44201765 (sq. yd)	10.0" 44201769 (sq. yd)	10.0" 44201771 (sq. yd)
2271+02	BD	LT	10	10	0.0	11.1	0.0	0.0
2271+02	WB	PL	10	11	0.0	12.2	0.0	0.0
2271+02	EB	PL	10	11	0.0	12.2	0.0	0.0
2272+00	BD	LT	10	10	0.0	11.1	0.0	0.0
2272+00	WB	PL	10	11	0.0	12.2	0.0	0.0
2272+00	EB	PL	10	11	0.0	12.2	0.0	0.0
2273+02	BD	LT	10	10	0.0	11.1	0.0	0.0
2273+02	WB	PL	10	11	0.0	12.2	0.0	0.0
2273+02	WB	DL	10	10	0.0	11.1	0.0	0.0
2274+02	BD	LT	6	10	0.0	6.7	0.0	0.0
2274+02	WB	DL	6	10	0.0	6.7	0.0	0.0
2274+02	EB	DL	6	10	0.0	6.7	0.0	0.0
2275+02	BD	LT	4	10	4.4	0.0	0.0	0.0
2275+02	WB	PL	4	11	4.9	0.0	0.0	0.0
2275+02	EB	DL	8	10	0.0	8.9	0.0	0.0
2276+02	BD	LT	8	10	0.0	8.9	0.0	0.0
2276+02	WB	PL	8	11	0.0	9.8	0.0	0.0
2276+02	WB	DL	8	10	0.0	8.9	0.0	0.0
2276+02	EB	PL	8	11	0.0	9.8	0.0	0.0
2277+02	BD	LT	8	10	0.0	8.9	0.0	0.0
2277+02	WB	PL	8	11	0.0	9.8	0.0	0.0
2277+02	WB	DL	8	10	0.0	8.9	0.0	0.0
2277+02	EB	PL	8	11	0.0	9.8	0.0	0.0
2279+02	BD	LT	8	10	0.0	8.9	0.0	0.0
2279+02	EB	PL	8	11	0.0	9.8	0.0	0.0
2280+02	BD	LT	8	10	0.0	8.9	0.0	0.0
2280+02	WB	PL	8	11	0.0	9.8	0.0	0.0
2280+02	WB	DL	8	10	0.0	8.9	0.0	0.0
2280+02	EB	PL	8	11	0.0	9.8	0.0	0.0
2283+02	BD	LT	8	10	0.0	8.9	0.0	0.0
2283+02	WB	PL	8	11	0.0	9.8	0.0	0.0
2283+02	WB	DL	8	10	0.0	8.9	0.0	0.0
2283+02	EB	PL	8	11	0.0	9.8	0.0	0.0
2283+02	EB	DL	8	10	0.0	8.9	0.0	0.0
2284+02	BD	LT	8	10	0.0	8.9	0.0	0.0
2284+02	WB	PL	8	11	0.0	9.8	0.0	0.0
2284+02	WB	DL	8	10	0.0	8.9	0.0	0.0
2284+02	EB	PL	8	11	0.0	9.8	0.0	0.0
2285+02	BD	LT	8	10	0.0	8.9	0.0	0.0
2285+02	WB	PL	8	11	0.0	9.8	0.0	0.0
2285+02	WB	DL	8	10	0.0	8.9	0.0	0.0
2285+02	EB	PL	8	6	0.0	5.3	0.0	0.0
2285+02	EB	DL	8	10	0.0	8.9	0.0	0.0
2286+02	BD	LT	8	10	0.0	8.9	0.0	0.0
2286+02	WB	DL	8	10	0.0	8.9	0.0	0.0
SHEET 1 SUB TOTALS:					9.3	408.2	0.0	0.0

SCHEDULES OF QUANTITIES

CLASS D PATCHES 10" (SHEET 2 OF 2)

STATION	DIRECTION	LANE	LENGTH	WIDTH	PATCH AREA			
					TYPE I 10.0" 44201761 (sq. yd)	TYPE II 10.0" 44201765 (sq. yd)	TYPE III 10.0" 44201769 (sq. yd)	TYPE IV 10.0" 44201771 (sq. yd)
2286+02	EB	PL	8	11	0.0	9.8	0.0	0.0
2286+02	EB	DL	8	10	0.0	8.9	0.0	0.0
2287+02	BD	MED	8	10	0.0	8.9	0.0	0.0
2287+02	WB	DL	8	12	0.0	10.7	0.0	0.0
2287+02	EB	PL	8	12	0.0	10.7	0.0	0.0
2287+02	EB	DL	8	12	0.0	10.7	0.0	0.0
2288+82	WB	PL	6	12	0.0	8.0	0.0	0.0
2289+02	BD	MED	8	12	0.0	10.7	0.0	0.0
2289+02	WB	PL	8	12	0.0	10.7	0.0	0.0
2289+02	WB	DL	8	12	0.0	10.7	0.0	0.0
2289+71	BD	MED	6	6	4.0	0.0	0.0	0.0
2289+71	WB	PL	6	6	4.0	0.0	0.0	0.0
2289+71	EB	PL	6	6	4.0	0.0	0.0	0.0
2290+11	WB	PL	6	6	4.0	0.0	0.0	0.0
2290+11	WB	DL	6	6	4.0	0.0	0.0	0.0
2292+55	WB	PL	6	12	0.0	8.0	0.0	0.0
2292+55	WB	DL	6	12	0.0	8.0	0.0	0.0
2292+90	EB	PL	30	6	0.0	0.0	20.0	0.0
2292+95	WB	PL	15	6	0.0	10.0	0.0	0.0
2293+04	WB	PL	8	12	0.0	10.7	0.0	0.0
2293+04	WB	DL	8	12	0.0	10.7	0.0	0.0
2293+04	EB	PL	8	12	0.0	10.7	0.0	0.0
2293+04	EB	DL	8	12	0.0	10.7	0.0	0.0
2294+03	WB	PL	8	12	0.0	10.7	0.0	0.0
2294+03	WB	DL	8	12	0.0	10.7	0.0	0.0
2294+03	EB	LT TURN	8	12	0.0	10.7	0.0	0.0
2294+03	EB	PL	8	12	0.0	10.7	0.0	0.0
2294+03	EB	DL	8	12	0.0	10.7	0.0	0.0
2294+54	WB	PL	6	6	4.0	0.0	0.0	0.0
2295+10	WB	PL	6	12	0.0	8.0	0.0	0.0
2295+02	EB	Lt.T&Med.	6	20	0.0	13.3	0.0	0.0
2298+90	EB	DL	6	12	0.0	8.0	0.0	0.0
2298+90	EB	PL	6	12	0.0	8.0	0.0	0.0
2349+81	BD	LT	6	12	0.0	8.0	0.0	0.0
2349+81	WB	RT	6	11	0.0	7.3	0.0	0.0
2349+81	WB	DL	6	12	0.0	8.0	0.0	0.0
2349+81	WB	PL	6	12	0.0	8.0	0.0	0.0
2354+69	BD	LT	6	12	0.0	8.0	0.0	0.0
2354+69	WB	DL	6	11	0.0	7.3	0.0	0.0
2354+69	WB	PL	6	12	0.0	8.0	0.0	0.0
104+44	BD	LT	12	14	0.0	0.0	18.7	0.0
SHEET 2 SUB TOTALS:					24.0	313.6	38.7	0.0

SHEET 1 SUB TOTALS:	9.3	408.2	0.0	0.0
----------------------------	------------	--------------	------------	------------

ROUNDED GRAND TOTALS:	33.0	722.0	39.0	0.0
------------------------------	-------------	--------------	-------------	------------

SCHEDULES OF QUANTITIES

CLASS D PATCHES 11" (SHEET 1 OF 2)

STATION	DIRECTION	LANE	LENGTH	WIDTH	PATCH AREA			
					TYPE I	TYPE II	TYPE III	TYPE IV
					11.0" 44201773 (sq. yd)	11.0" 44201777 (sq. yd)	11.0" 44201781 (sq. yd)	11.0" 44201783 (sq. yd)
2301+11	EB	DL	10	10	0.0	11.1	0.0	0.0
2301+11	EB	PL	10	11	0.0	12.2	0.0	0.0
2301+11	BD	LT	6	10	0.0	6.7	0.0	0.0
2301+11	WB	DL	6	10	0.0	6.7	0.0	0.0
2301+11	WB	PL	6	11	0.0	7.3	0.0	0.0
2310+15	EB	DL	20	10	0.0	0.0	22.2	0.0
2310+15	EB	PL	20	11	0.0	0.0	24.4	0.0
2310+99	EB	DL	12	10	0.0	13.3	0.0	0.0
2310+99	EB	PL	12	11	0.0	14.7	0.0	0.0
2310+99	BD	LT	12	10	0.0	13.3	0.0	0.0
2310+99	WB	DL	12	10	0.0	13.3	0.0	0.0
2310+99	WB	PL	12	11	0.0	14.7	0.0	0.0
2320+25	EB	DL	6	10	0.0	6.7	0.0	0.0
2320+25	EB	PL	6	11	0.0	7.3	0.0	0.0
2320+25	WB	DL	6	10	0.0	6.7	0.0	0.0
2320+25	WB	PL	6	11	0.0	7.3	0.0	0.0
2325+69	EB	DL	6	10	0.0	6.7	0.0	0.0
2325+69	EB	PL	6	11	0.0	7.3	0.0	0.0
2325+69	BD	LT	6	10	0.0	6.7	0.0	0.0
2325+69	WB	DL	6	10	0.0	6.7	0.0	0.0
2325+69	WB	PL	6	11	0.0	7.3	0.0	0.0
2326+08	EB	DL	6	10	0.0	6.7	0.0	0.0
2326+08	EB	PL	6	11	0.0	7.3	0.0	0.0
2326+08	BD	LT	6	10	0.0	6.7	0.0	0.0
2326+08	WB	DL	6	10	0.0	6.7	0.0	0.0
2326+08	WB	PL	6	11	0.0	7.3	0.0	0.0
2328+73	EB	DL	6	10	0.0	6.7	0.0	0.0
2328+73	EB	PL	6	11	0.0	7.3	0.0	0.0
2328+73	BD	LT	6	10	0.0	6.7	0.0	0.0
2328+73	WB	DL	6	10	0.0	6.7	0.0	0.0
SHEET 1 SUB TOTALS:					0.0	238.0	46.7	0.0

SCHEDULES OF QUANTITIES

CLASS D PATCHES 11" (SHEET 2 OF 2)

STATION	DIRECTION	LANE	LENGTH	WIDTH	PATCH AREA			
					TYPE I 11.0" 44201773 (sq. yd)	TYPE II 11.0" 44201777 (sq. yd)	TYPE III 11.0" 44201781 (sq. yd)	TYPE IV 11.0" 44201783 (sq. yd)
2328+73	WB	PL	6	11	0.0	7.3	0.0	0.0
2331+51	EB	DL	6	10	0.0	6.7	0.0	0.0
2331+51	EB	PL	6	11	0.0	7.3	0.0	0.0
2331+51	BD	L T	6	10	0.0	6.7	0.0	0.0
2331+51	WB	PL	6	11	0.0	7.3	0.0	0.0
2336+77	EB	DL	8	10	0.0	8.9	0.0	0.0
2336+77	EB	PL	8	11	0.0	9.8	0.0	0.0
2336+77	BD	L T	8	10	0.0	8.9	0.0	0.0
2336+77	WB	DL	8	10	0.0	8.9	0.0	0.0
2336+77	WB	PL	8	11	0.0	9.8	0.0	0.0
2339+90	EB	DL	6	10	0.0	6.7	0.0	0.0
2339+90	EB	PL	6	11	0.0	7.3	0.0	0.0
2339+90	BD	L T	6	10	0.0	6.7	0.0	0.0
2339+90	WB	DL	6	10	0.0	6.7	0.0	0.0
2339+90	WB	PL	6	11	0.0	7.3	0.0	0.0
2341+80	EB	DL	6	10	0.0	6.7	0.0	0.0
2341+80	EB	PL	6	11	0.0	7.3	0.0	0.0
2341+80	BD	L T	6	10	0.0	6.7	0.0	0.0
2341+80	WB	DL	6	10	0.0	6.7	0.0	0.0
2341+80	WB	PL	6	11	0.0	7.3	0.0	0.0
2346+76	EB	DL	6	11	0.0	7.3	0.0	0.0
2346+76	EB	PL	6	12	0.0	8.0	0.0	0.0
2357+40	EB	DL	6	10	0.0	6.7	0.0	0.0
2357+40	EB	PL	6	11	0.0	7.3	0.0	0.0
2357+40	BD	L T	6	10	0.0	6.7	0.0	0.0
2357+40	WB	DL	6	11	0.0	7.3	0.0	0.0
2357+40	WB	PL	6	11	0.0	7.3	0.0	0.0
2357+49	EB	DL	6	10	0.0	6.7	0.0	0.0
2357+49	EB	PL	6	11	0.0	7.3	0.0	0.0

SHEET 2 SUB TOTALS:	0.0	215.6	0.0	0.0
----------------------------	-----	-------	-----	-----

SHEET 1 SUB TOTALS:	0.0	238.0	46.7	0.0
----------------------------	-----	-------	------	-----

ROUNDED GRAND TOTALS:	0.0	454.0	47.0	0.0
------------------------------	-----	-------	------	-----

SCHEDULES OF QUANTITIES

PARTIAL DEPTH PATCHING

STATION	DIRECTION	LANE	LENGTH (ft)	WIDTH (ft)	EXISTING HMA OVERLAY THICKNESS (4 3/4" or less) (inch)	PARTIAL DEPTH REMOVAL X4401705 (sq. yd)	PARTIAL DEPTH PATCHING X4421000 (tons)
2307+97	EB	DL	6	10	3	6.7	2.2
2307+97	EB	PL	6	11	3	7.3	2.5
2307+97	BD	LT	6	10	3	6.7	2.2
2309+72	WB	DL	6	10	3	6.7	2.2
2309+72	WB	PL	6	11	3	7.3	2.5
2309+97	WB	DL	6	10	3	6.7	2.2
2309+97	WB	PL	6	11	3	7.3	2.5
2315+23	WB	PL	6	11	3	7.3	2.5
2315+39	EB	PL	6	11	3	7.3	2.5
2315+39	BD	LT	6	10	3	6.7	2.2
2315+39	WB	PL	6	11	3	7.3	2.5
2316+38	EB	PL	6	11	3	7.3	2.5
2316+38	BD	LT	6	10	3	6.7	2.2
2316+38	WB	PL	6	11	3	7.3	2.5
2319+51	EB	DL	6	10	3	6.7	2.2
2319+51	EB	PL	6	11	3	7.3	2.5
2319+51	BD	LT	6	10	3	6.7	2.2
2319+51	WB	DL	6	10	3	6.7	2.2
2319+51	WB	PL	6	11	3	7.3	2.5
2323+03	EB	PL	10	11	3	12.2	4.1
2323+03	WB	DL	6	10	3	6.7	2.2
2323+03	WB	PL	6	11	3	7.3	2.5
2333+73	WB	DL	6	10	3	6.7	2.2
2333+73	WB	PL	6	11	3	7.3	2.5
2348+19	EB	DL	6	11	3	7.3	2.5
2348+19	EB	PL	6	12	3	8.0	2.7
2349+33	EB	DL	6	11	3	7.3	2.5
2349+33	EB	PL	6	12	3	8.0	2.7
2351+91	EB	DL	6	11	3	7.3	2.5
2351+91	EB	PL	6	12	3	8.0	2.7
TOTALS						219.6 (sq. yd)	73.8 (tons)
ROUND TO						220.0	74.0

SCHEDULES OF QUANTITIES

78000200 THERMOPLASTIC PAVEMENT MARKING, LINE 4"

STA.	TO	STA.	4" WHITE (FEET)	4" YELLOW (FEET)	TOTAL (FEET)
2270+54.60		2298+12.86	1,878.0	5,952.0	7,830.0
2298+14.21		2303+23.32	347.0	1,098.0	1,445.0
2305+13.70		2362+39.04	3,941.0	12,233.0	16,174.0
100+00.00		105+64.00	384.0	1,217.0	1,601.0
GRAND TOTAL =					27,050.0

78000600 THERMOPLASTIC PAVEMENT MARKING, LINE 12"

STA.	TO	STA.	# DIAGONALS	AVE. LENGTH (FEET)	TOTAL LENGTH (FEET)
2288+38		2294+95	23	9'	207.0
2296+17		2298+59	11	8'	88.0
TOTAL =					295.0
ROUND TO:					300.0

78000650 THERMOPLASTIC PAVEMENT MARKING, LINE 24"

STA.	TO	STA.	OFFSET	LENGTH (FEET)
TANNER STREET				
2294+94		2294+94	RT.	50.0
2295+00		2295+50	LT.	50.0
2296+18		2296+18	LT.	50.0
2295+48		2295+98	RT.	50.0
FREDRICK STREET				
2313+33		2313+35	RT.	34.0
2314+18		2314+20	LT.	37.0
GROVE STREET				
2348+44		2348+46	RT.	37.0
2349+43		2349+45	LT.	50.0
MAPLEWOOD DRIVE				
100+02		100+05	RT.	45.0
101+11		101+13	LT.	47.0
STOP BARS TOTAL =				450.0

78000400 THERMOPLASTIC PAVEMENT MARKING, LINE 6"

STREET	STA.	TO	STA.	LENGTH (FEET)
TANNER MAINLINE	2295+00 RT.		2295+00 LT.	111.0
TANNER MAINLINE	2295+06 RT.		2296+06 LT.	107.0
TANNER MAINLINE	2296+07 RT.		2296+07 LT.	107.0
TANNER MAINLINE	2296+13 RT.		2296+13 LT.	109.0
TANNER	2294+97 LT.		2296+04 LT.	107.0
TANNER	2294+99 LT.		2296+01 LT.	102.0
TANNER	2295+07 RT.		2296+09 RT.	102.0
TANNER	2295+07 RT.		2296+09 RT.	102.0
GERRARD MAINLINE	2299+52 LT.		2299+55 RT.	80.0
GERRARD MAINLINE	2299+58 LT.		2299+61 RT.	83.0
GERRARD MAINLINE	2300+22 RT.		2300+24 LT.	79.0
GERRARD MAINLINE	2300+28 RT.		2300+30 LT.	76.0
GERRARD	649+56 LT.		649+58 RT.	60.0
GERRARD	649+62 LT.		649+64 RT.	61.0
GERRARD	650+42 RT.		650+45 LT.	66.0
GERRARD	650+48 RT.		650+51 LT.	67.0
FREDRICK	2313+39 RT.		2313+39 LT.	58.0
FREDRICK	2313+45 RT.		2313+45 LT.	61.0
FREDRICK	2314+08 RT.		2314+08 LT.	74.0
FREDRICK	2314+14 RT.		2314+14 LT.	65.0
CHANUTE	2330+29 RT.		2330+53 LT.	62.0
CHANUTE	2330+35 RT.		2330+59 LT.	83.0
GROVE	2349+33 RT.		2349+33 LT.	80.0
GROVE	2349+39 RT.		2349+39 LT.	78.0
MAPLEWOOD	100+08 RT.		100+11 LT.	81.0
MAPLEWOOD	100+14 RT.		100+17 LT.	88.0
MAPLEWOOD	101+01 RT.		101+01 LT.	89.0
MAPLEWOOD	101+07 RT.		101+07 LT.	87.0
CROSSWALK TOTAL =				2,325.0

TRAFFIC SIGNAL PAY ITEMS

STREET	CONDUIT IN TRENCH, 1" DIA., PVC 81012300 (FOOT)	CONDUIT IN TRENCH, 1 1/2" DIA., PVC 81012500 (FOOT)	HANDHOLE 81400100 (EACH)	TRENCH AND BACKFILL FOR ELECTRICAL WORK 81900200 (FOOT)	DETECTOR LOOP, TYPE 1 88600100 (FOOT)
TANNER	0.0	0.0	0.0	0.0	139.0
FREDRICK	20.0	4.0	2.0	24.0	128.0
GROVE	0.0	0.0	0.0	0.0	368.0
MAPLEWOOD	0.0	0.0	0.0	0.0	373.0
TOTALS =	20.0	4.0	2.0	24.0	1008.0

SCHEDULES OF QUANTITIES

78000100 THERMOPLASTIC PAVMENT MARKING (LETTERS & SYMBOLS)

STATION	LETTER/SYMBOL	# EACH	SQ. FT.
2270+56	TURN ARROW	1.0	15.6
2270+77	TURN ARROW	1.0	15.6
2272+76	TURN ARROW	1.0	15.6
2272+97	TURN ARROW	1.0	15.6
2274+97	TURN ARROW	1.0	15.6
2275+19	TURN ARROW	1.0	15.6
2277+18	TURN ARROW	1.0	15.6
2277+40	TURN ARROW	1.0	15.6
2278+94	TURN ARROW	1.0	15.6
2279+16	TURN ARROW	1.0	15.6
2281+11	TURN ARROW	1.0	15.6
2281+34	TURN ARROW	1.0	15.6
2283+31	TURN ARROW	1.0	15.6
2283+52	TURN ARROW	1.0	15.6
2285+49	TURN ARROW	1.0	15.6
2285+70	TURN ARROW	1.0	15.6
2286+59	TURN ARROW	1.0	15.6
2287+00	TURN ARROW	1.0	15.6
2287+41	TURN ARROW	1.0	15.6
2293+69	TURN ARROW	1.0	15.6
2294+20	TURN ARROW	1.0	15.6
2294+74	TURN ARROW	1.0	15.6
2296+36	TURN ARROW	1.0	15.6
2296+80	TURN ARROW	1.0	15.6
2297+20	TURN ARROW	1.0	15.6
Tanner St. North Leg	TURN ARROW	6.0	93.6
Tanner St. South Leg	TURN ARROW	3.0	46.8
2298+72.5	TURN ARROW	1.0	15.6
2298+36.8	TURN ARROW	1.0	15.6
2300+46.5	TURN ARROW	1.0	15.6
2300+99	TURN ARROW	1.0	15.6
2301+74	TURN ARROW	1.0	15.6
2301+98	TURN ARROW	1.0	15.6
2302+72.7	TURN ARROW	1.0	15.6
2303+54.7	TURN ARROW	1.0	15.6
2304+94	TURN ARROW	1.0	15.6
2305+76	TURN ARROW	1.0	15.6
2307+29	TURN ARROW	1.0	15.6
2307+53	TURN ARROW	1.0	15.6
2310+52	TURN ARROW	1.0	15.6
2310+76	TURN ARROW	1.0	15.6
2312+33	TURN ARROW	1.0	15.6
2313+15	TURN ARROW	1.0	15.6
2314+38	TURN ARROW	1.0	15.6
2315+20	TURN ARROW	1.0	15.6
2316+83	TURN ARROW	1.0	15.6
2317+07	TURN ARROW	1.0	15.6
2320+35	TURN ARROW	1.0	15.6
2320+59	TURN ARROW	1.0	15.6

78000100 THERMOPLASTIC PAVMENT MARKING (LETTERS & SYMBOLS) CONTINUED

STATION	LETTER/SYMBOL	# EACH	SQ. FT.
2322+85	TURN ARROW	1.0	15.6
2323+09	TURN ARROW	1.0	15.6
2325+35	TURN ARROW	1.0	15.6
2325+59	TURN ARROW	1.0	15.6
2328+81	TURN ARROW	1.0	15.6
2329+05	TURN ARROW	1.0	15.6
2332+01	TURN ARROW	1.0	15.6
2332+25	TURN ARROW	1.0	15.6
2334+51	TURN ARROW	1.0	15.6
2334+75	TURN ARROW	1.0	15.6
2336+95	TURN ARROW	1.0	15.6
2337+19	TURN ARROW	1.0	15.6
2339+45	TURN ARROW	1.0	15.6
2339+69	TURN ARROW	1.0	15.6
2341+68	TURN ARROW	1.0	15.6
2341+92	TURN ARROW	1.0	15.6
2343+75	TURN ARROW	1.0	15.6
2343+99	TURN ARROW	1.0	15.6
2345+82	TURN ARROW	1.0	15.6
2346+06	TURN ARROW	1.0	15.6
2347+44	TURN ARROW	1.0	15.6
2348+26	TURN ARROW	1.0	15.6
2349+63	TURN ARROW	1.0	15.6
2350+33	TURN ARROW	1.0	15.6
2350+45	TURN ARROW	1.0	15.6
2350+69	TURN ARROW	1.0	15.6
2351+03	TURN ARROW	1.0	15.6
2352+95	TURN ARROW	1.0	15.6
2353+00	TURN ARROW	1.0	15.6
2353+19	TURN ARROW	1.0	15.6
2353+80	TURN ARROW	1.0	15.6
2353+60	TURN ARROW	1.0	15.6
2355+40	TURN ARROW	1.0	15.6
2355+45	TURN ARROW	1.0	15.6
2355+69	TURN ARROW	1.0	15.6
2356+20	TURN ARROW	1.0	15.6
2357+00	TURN ARROW	1.0	15.6
2357+80	TURN ARROW	1.0	15.6
2358+60	TURN ARROW	1.0	15.6
2358+88	TURN ARROW	1.0	15.6
2359+12	TURN ARROW	1.0	15.6
2359+40	TURN ARROW	1.0	15.6
2361+41	TURN ARROW	1.0	15.6
2362+23	TURN ARROW	1.0	15.6
101+31	TURN ARROW	1.0	15.6
102+13	TURN ARROW	1.0	15.6
104+20	TURN ARROW	1.0	15.6
104+44	TURN ARROW	1.0	15.6
TOTAL			1622.0

FILE NAME =	USER NAME = hoganbj	DESIGNED -	REVISED -
ct:\pw\work\pmdot\hoganbj\0104446\0570	17-shit-Schedule.dgn	DRAWN -	REVISED -
	PLOT SCALE = 100.0000' / IN.	CHECKED -	REVISED -
	PLOT DATE = 1/29/2010	DATE -	REVISED -

**STATE OF ILLINOIS
DEPARTMENT OF TRANSPORTATION**

SCHEDULES OF QUANTITIES

SCALE: N/A SHEET NO. 14 OF 14 SHEETS STA. TO STA.

F.A.P. RTE.	SECTION	COUNTY	TOTAL SHEETS	SHEET NO.
709	(113)RS-1	CHAMPAIGN	65	35
FED. ROAD DIST. NO. ILLINOIS FED. AID PROJECT			CONTRACT NO. 70117	

SEC. 3, T21N, R9E

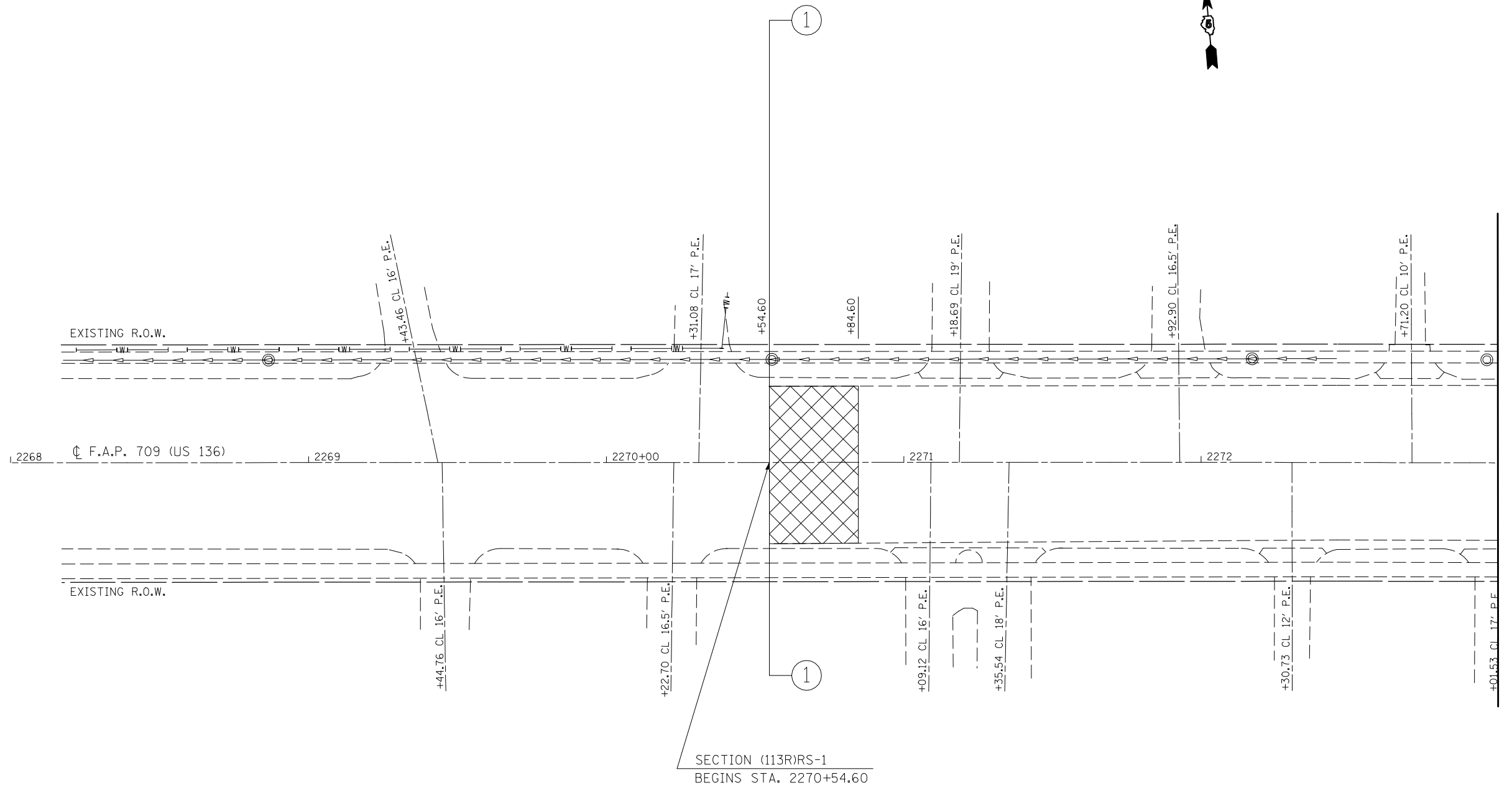

SECTION (113R)RS-1
BEGINS STA. 2270+54.60

- NOTES:
1. PLAN SHEET TOPO DRAWN FROM AS-BUILT PLANS. DRAWING NOT TO SCALE.
 2. DRAINAGE SHALL BE MAINTAINED THROUGH ALL ENTRANCES.
 3. SEE SPECIAL PROVISIONS FOR REQUIREMENTS OF OPENING MANHOLES AND WATER VALVE BOXES AFTER RESURFACING IS COMPLETE.

P.C.C. SURFACE REM., BUTT JOINT

FILE NAME = ct:\pw\work\PWIDOT\HOGANBJ\d0104446\7017\sheets.dgn	USER NAME = hoganbj	DESIGNED - BJM	REVISED -	STATE OF ILLINOIS DEPARTMENT OF TRANSPORTATION	PLAN SHEETS	F.A.P. RTE. 709	SECTION (113R)RS-1	COUNTY CHAMPAIGN	TOTAL SHEETS 65	SHEET NO. 36	
PLOT SCALE = 40.0000' / IN.	CHECKED -	REVISIED -	REVISIED -			SCALE: 1" = 20'		SHEET NO. 1 OF 20 SHEETS		STA. 2268+00 TO STA. 2273+00	
PLOT DATE = 1/29/2010	DATE - 1/21/2010	REVISIED -	REVISIED -			FED. ROAD DIST. NO. ILLINOIS FED. AID PROJECT					
CONTRACT NO. 70117											

SEC. 3, T21N, R9E

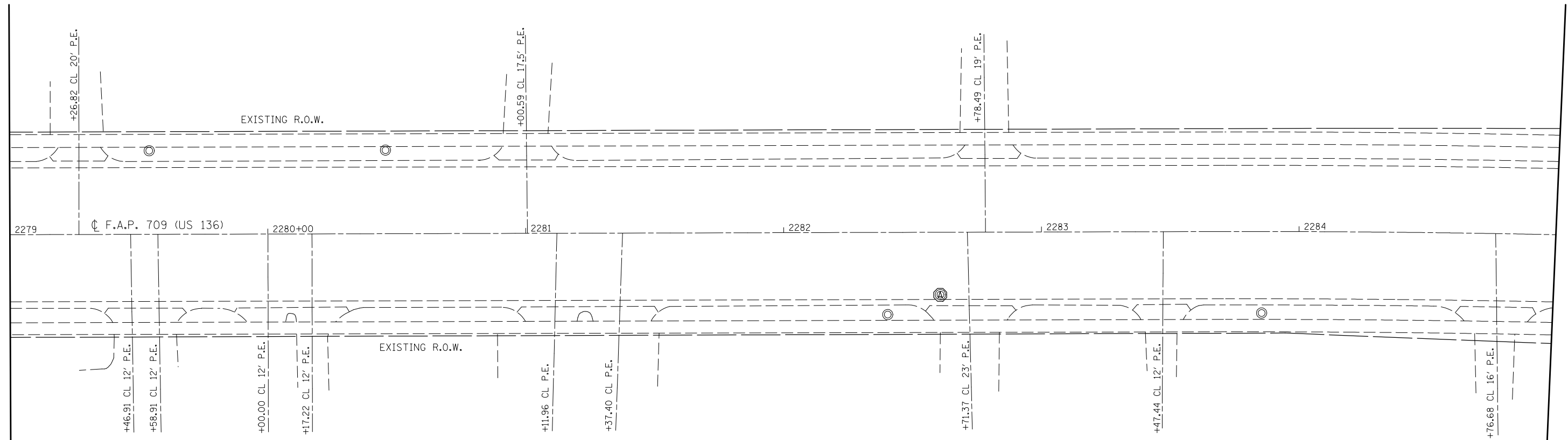

NOTES:

1. PLAN SHEET TOPO DRAWN FROM AS-BUILT PLANS. DRAWING NOT TO SCALE.
2. DRAINAGE SHALL BE MAINTAINED THROUGH ALL ENTRANCES.
3. SEE SPECIAL PROVISIONS FOR REQUIREMENTS OF OPENING MANHOLES AND WATER VALVE BOXES AFTER RESURFACING IS COMPLETE.

A MANHOLES TO BE ADJUSTED

FILE NAME = c:\pwork\work\PWIDOT\HOGANBJ\d0104446\70177sheets.dgn	USER NAME = hoganbj	DESIGNED - BJM	REVISED -
PLOT SCALE = 40.0000' / IN.	CHECKED -	DRAWN - BJH	REVISED -
PLOT DATE = 1/29/2010	DATE - 1/21/2010		REVISED -

**STATE OF ILLINOIS
DEPARTMENT OF TRANSPORTATION**

PLAN SHEETS

SCALE: 1" = 20' SHEET NO. 3 OF 20 SHEETS STA. 2279+00 TO STA. 2285+00

F.A.P. RTE.	SECTION	COUNTY	TOTAL SHEETS	SHEET NO.
709	(113)RS-1	CHAMPAIGN	65	38
FED. ROAD DIST. NO. ILLINOIS FED. AID PROJECT			CONTRACT NO. 70117	

SEC. 3, T21N, R9E



EXIST. CURVE DATA
 PI STA. = 2287+01.01
 Δ = 6° 36' 15" (RT)
 D = 1° 00' 11"
 R = 5,712.60'
 T = 329.59'
 L = 658.45'
 E = 9.50'
 P.C. STA. = 2283+71.41
 P.T. STA. = 2290+29.87

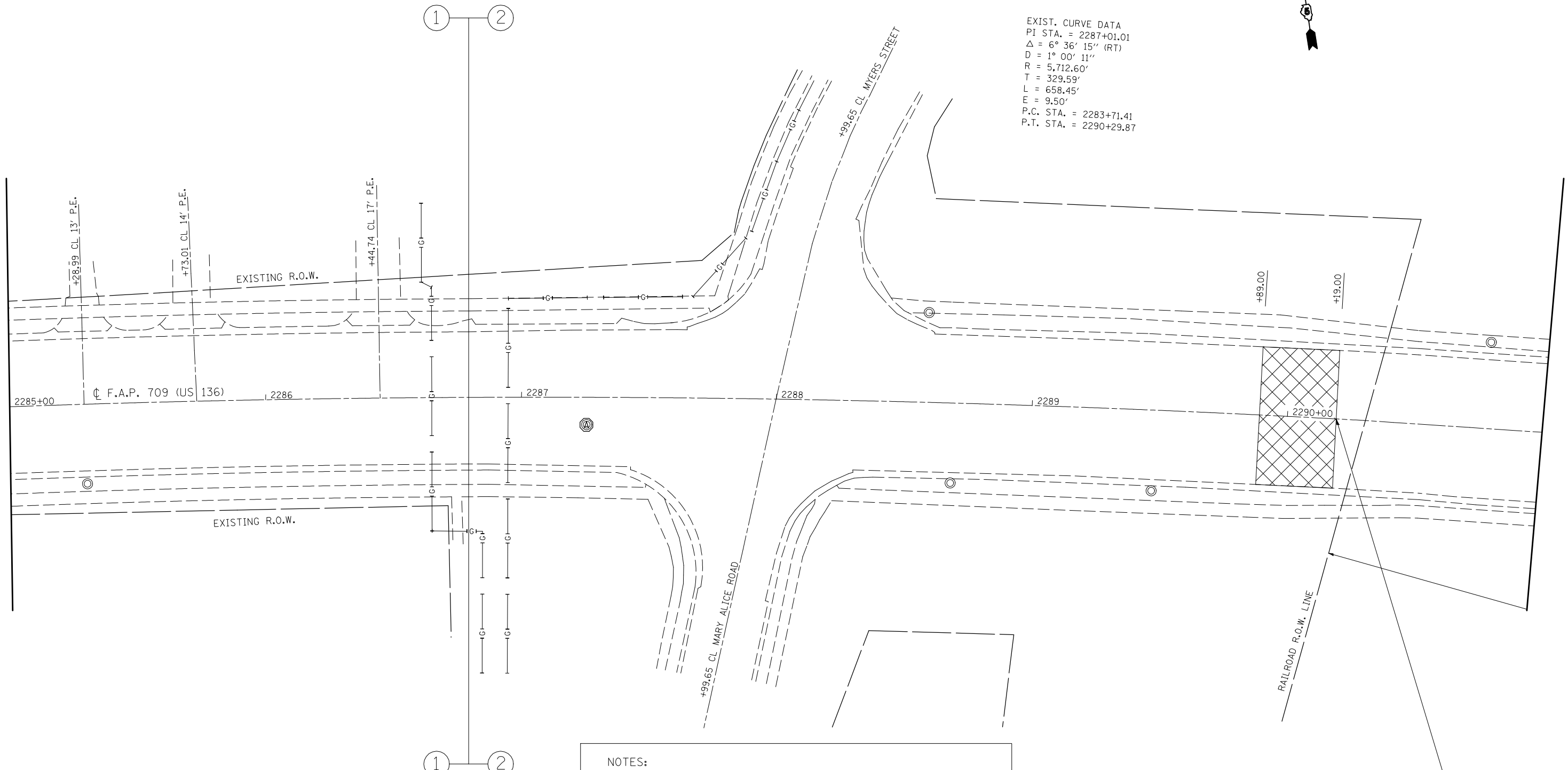

NOTES:

1. PLAN SHEET TOPO DRAWN FROM AS-BUILT PLANS. DRAWING NOT TO SCALE.
2. DRAINAGE SHALL BE MAINTAINED THROUGH ALL ENTRANCES.
3. SEE SPECIAL PROVISIONS FOR REQUIREMENTS OF OPENING MANHOLES AND WATER VALVE BOXES AFTER RESURFACING IS COMPLETE.

OMISSION FOR RR OVERPASS
 STA. 2290+19.00 TO STA. 2292+45.00



MANHOLES TO BE ADJUSTED



P.C.C. SURFACE REM., BUTT JOINT

FILE NAME =	USER NAME = hoganbj	DESIGNED - BJM	REVISED -
ct:\pw\work\PWIDOT\HOGANBJ\d0104446\7017\sheets.dgn		DRAWN - BJH	REVISED -
	PLOT SCALE = 40.0000' / IN.	CHECKED -	REVISED -
	PLOT DATE = 1/29/2010	DATE - 1/21/2010	REVISED -

STATE OF ILLINOIS
 DEPARTMENT OF TRANSPORTATION

PLAN SHEETS

SCALE: 1" = 20' SHEET NO. 4 OF 20 SHEETS STA. 2285+00 TO STA. 2291+00

F.A.P. RTE.	SECTION	COUNTY	TOTAL SHEETS	SHEET NO.
709	(113)RS-1	CHAMPAIGN	65	39
FED. ROAD DIST. NO.			ILLINOIS FED. AID PROJECT	
			CONTRACT NO. 70117	

SEC. 3, T21N, R9E

EXIST. CURVE DATA
 PI STA. = 2295+02.08
 $\Delta = 6^\circ 12' 38''$ (LT)
 $D = 1^\circ 00' 09''$
 $R = 5,715.11'$
 $T = 310.05'$
 $L = 619.49'$
 $E = 8.40'$
 P.C. STA. = 2291+92.03
 P.T. STA. = 2298+11.50



SEC. 2, T21N, R9E

NOTES:

1. PLAN SHEET TOPO DRAWN FROM AS-BUILT PLANS. DRAWING NOT TO SCALE.
2. DRAINAGE SHALL BE MAINTAINED THROUGH ALL ENTRANCES.
3. SEE SPECIAL PROVISIONS FOR REQUIREMENTS OF OPENING MANHOLES AND WATER VALVE BOXES AFTER RESURFACING IS COMPLETE.

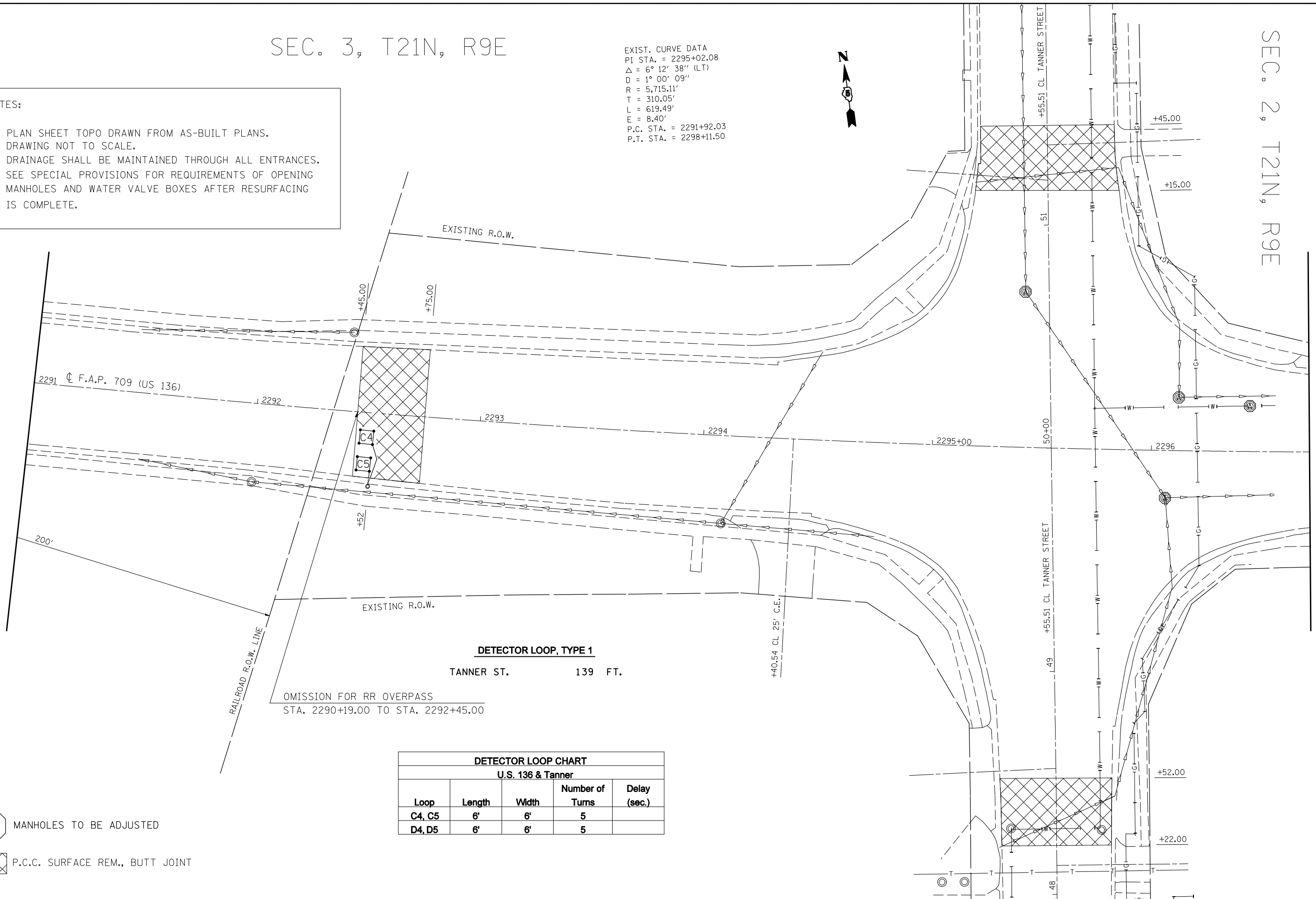

DETECTOR LOOP, TYPE 1
 TANNER ST. 139 FT.

OMISSION FOR RR OVERPASS
 STA. 2290+19.00 TO STA. 2292+45.00

DETECTOR LOOP CHART				
U.S. 136 & Tanner				
Loop	Length	Width	Number of Turns	Delay (sec.)
C4, C5	6'	6'	5	
D4, D5	6'	6'	5	



MANHOLES TO BE ADJUSTED



P.C.C. SURFACE REM., BUTT JOINT

FILE NAME =	USER NAME = hoganbj	DESIGNED - BJM	REVISED -
ct:\pw\work\PWIDOT\HOGANBJ\d0104446\7017\sheets.dgn		DRAWN - BJH	REVISED -
	PLOT SCALE = 40.0000' / IN.	CHECKED -	REVISED -
	PLOT DATE = 1/29/2010	DATE - 1/21/2010	REVISED -

STATE OF ILLINOIS
 DEPARTMENT OF TRANSPORTATION

PLAN SHEETS

SCALE: 1" = 20' SHEET NO. 5 OF 20 SHEETS STA. 2291+00 TO STA. 2296+70

F.A.P. RTE.	SECTION	COUNTY	TOTAL SHEETS	SHEET NO.
709	(113R)RS-1	CHAMPAIGN	65	40
CONTRACT NO. 70117				
FED. ROAD DIST. NO.		ILLINOIS FED. AID PROJECT		

SEC. 2, T21N, R9E

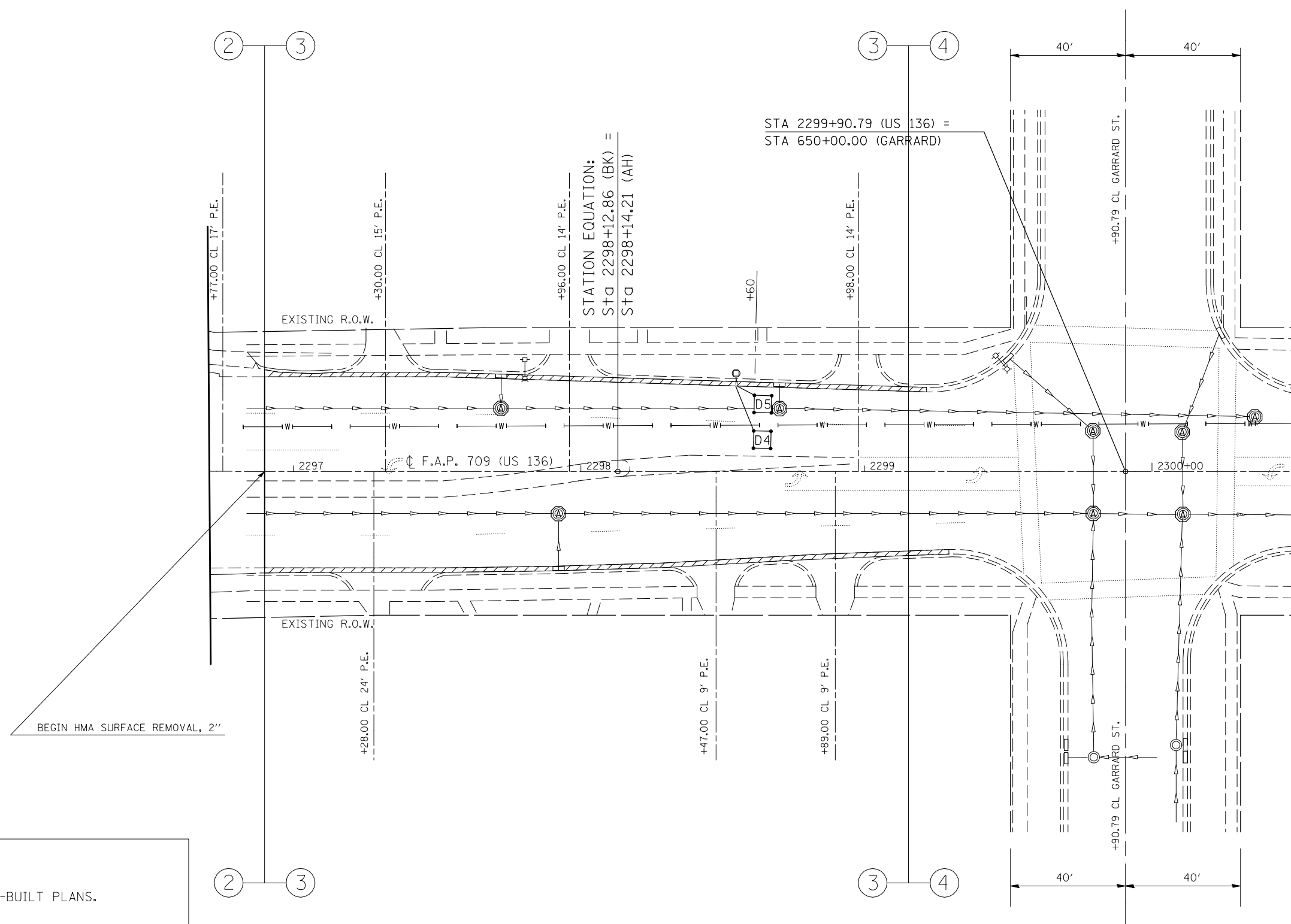

- NOTES:
1. PLAN SHEET TOPO DRAWN FROM AS-BUILT PLANS. DRAWING NOT TO SCALE.
 2. DRAINAGE SHALL BE MAINTAINED THROUGH ALL ENTRANCES.
 3. SEE SPECIAL PROVISIONS FOR REQUIREMENTS OF OPENING MANHOLES AND WATER VALVE BOXES AFTER RESURFACING IS COMPLETE.

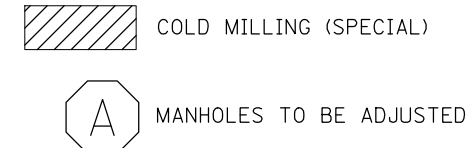

FILE NAME = c:\pwork\pwork\hoganbj\d0104446\7017	USER NAME = hoganbj sheets.dgn	DESIGNED - BJM DRAWN - BJH	REVISED - REVISED - REVISED - REVISED -	STATE OF ILLINOIS DEPARTMENT OF TRANSPORTATION	PLAN SHEETS			F.A.P. RTE. 709	SECTION (113R/RS-1)	COUNTY CHAMPAIGN	TOTAL SHEETS 65	SHEET NO. 41
	PLOT SCALE = 40.0000' / IN. PLOT DATE = 1/29/2010	CHECKED - DATE - 1/21/2010			SCALE: 1" = 20'	SHEET NO. 6 OF 20 SHEETS	STA. 2296+70 TO STA. 2300+50	FED. ROAD DIST. NO.	ILLINOIS FED. AID PROJECT	CONTRACT NO. 70117		

SEC. 2, T21N, R9E

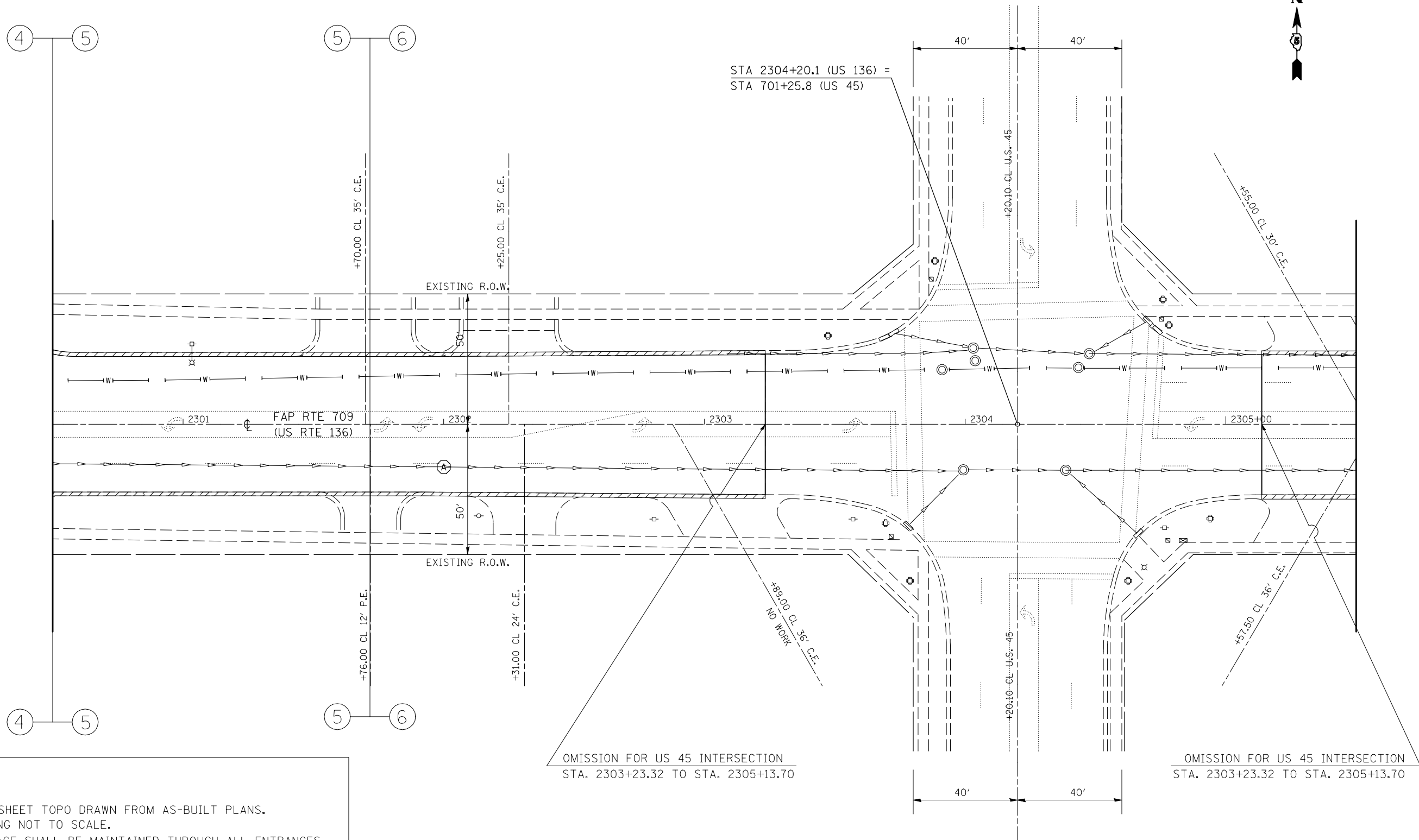

- NOTES:
1. PLAN SHEET TOPO DRAWN FROM AS-BUILT PLANS. DRAWING NOT TO SCALE.
 2. DRAINAGE SHALL BE MAINTAINED THROUGH ALL ENTRANCES.
 3. SEE SPECIAL PROVISIONS FOR REQUIREMENTS OF OPENING MANHOLES AND WATER VALVE BOXES AFTER RESURFACING IS COMPLETE.

FILE NAME = c:\pwork\pwork\hoganbj\d0104446\7017	USER NAME = hoganbj sheets.dgn	DESIGNED - BJM	REVISED -
	PLOT SCALE = 40.0000' / IN.	DRAWN - BJH	REVISED -
	PLOT DATE = 1/29/2010	CHECKED -	REVISED -
		DATE - 1/21/2010	REVISED -

**STATE OF ILLINOIS
DEPARTMENT OF TRANSPORTATION**

PLAN SHEETS

SCALE: 1" = 20' SHEET NO. 7 OF 20 SHEETS STA. 2300+50 TO STA. 2305+50

F.A.P. RTE. 709	SECTION (113R/R5-1)	COUNTY CHAMPAIGN	TOTAL SHEETS 65	SHEET NO. 42
FED. ROAD DIST. NO.		ILLINOIS FED. AID PROJECT		

COLD MILLING (SPECIAL)

SEC. 2, T21N, R9E

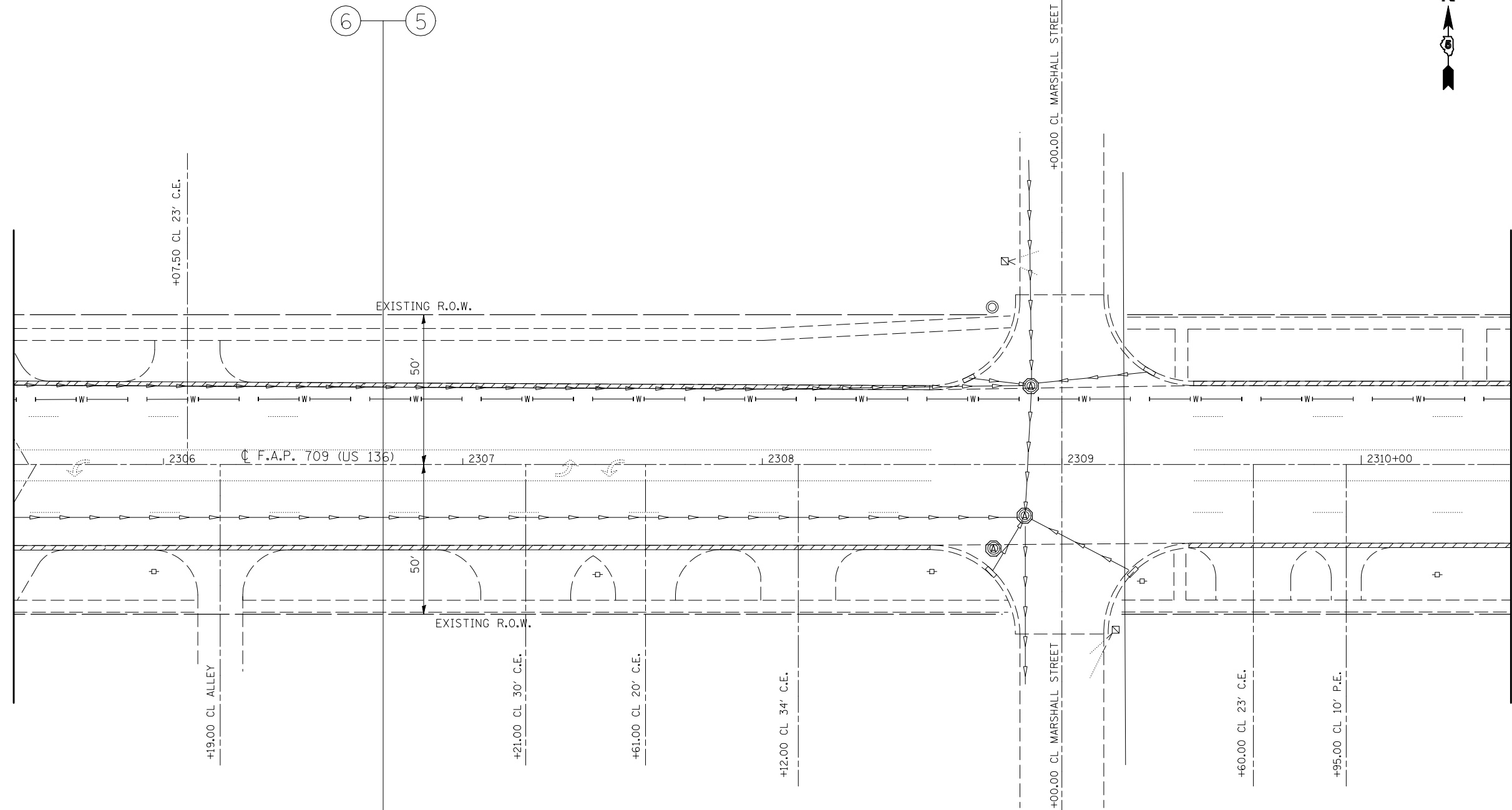

6 5

6 5

- NOTES:
1. PLAN SHEET TOPO DRAWN FROM AS-BUILT PLANS. DRAWING NOT TO SCALE.
 2. DRAINAGE SHALL BE MAINTAINED THROUGH ALL ENTRANCES.
 3. SEE SPECIAL PROVISIONS FOR REQUIREMENTS OF OPENING MANHOLES AND WATER VALVE BOXES AFTER RESURFACING IS COMPLETE.

 COLD MILLING (SPECIAL)

 MANHOLES TO BE ADJUSTED

FILE NAME =	USER NAME = hoganbj	DESIGNED - BJM	REVISED -
ct:\pw\work\PWIDOT\HOGANBJ\d0104446\7017\sheets.dgn		DRAWN - BJH	REVISED -
	PLOT SCALE = 40.0000' / IN.	CHECKED -	REVISED -
	PLOT DATE = 1/29/2010	DATE - 1/21/2010	REVISED -

STATE OF ILLINOIS
DEPARTMENT OF TRANSPORTATION

PLAN SHEETS

SCALE: 1" = 20' SHEET NO. 8 OF 20 SHEETS STA. 2305+50 TO STA. 2310+50

F.A.P. RTE.	SECTION	COUNTY	TOTAL SHEETS	SHEET NO.
709	(113R)RS-1	CHAMPAIGN	65	43
FED. ROAD DIST. NO. ILLINOIS FED. AID PROJECT			CONTRACT NO. 70117	

NOTES:

1. PLAN SHEET TOPO DRAWN FROM AS-BUILT PLANS. DRAWING NOT TO SCALE.
2. DRAINAGE SHALL BE MAINTAINED THROUGH ALL ENTRANCES.
3. SEE SPECIAL PROVISIONS FOR REQUIREMENTS OF OPENING MANHOLES AND WATER VALVE BOXES AFTER RESURFACING IS COMPLETE.

SEC. 2, T21N, R9E

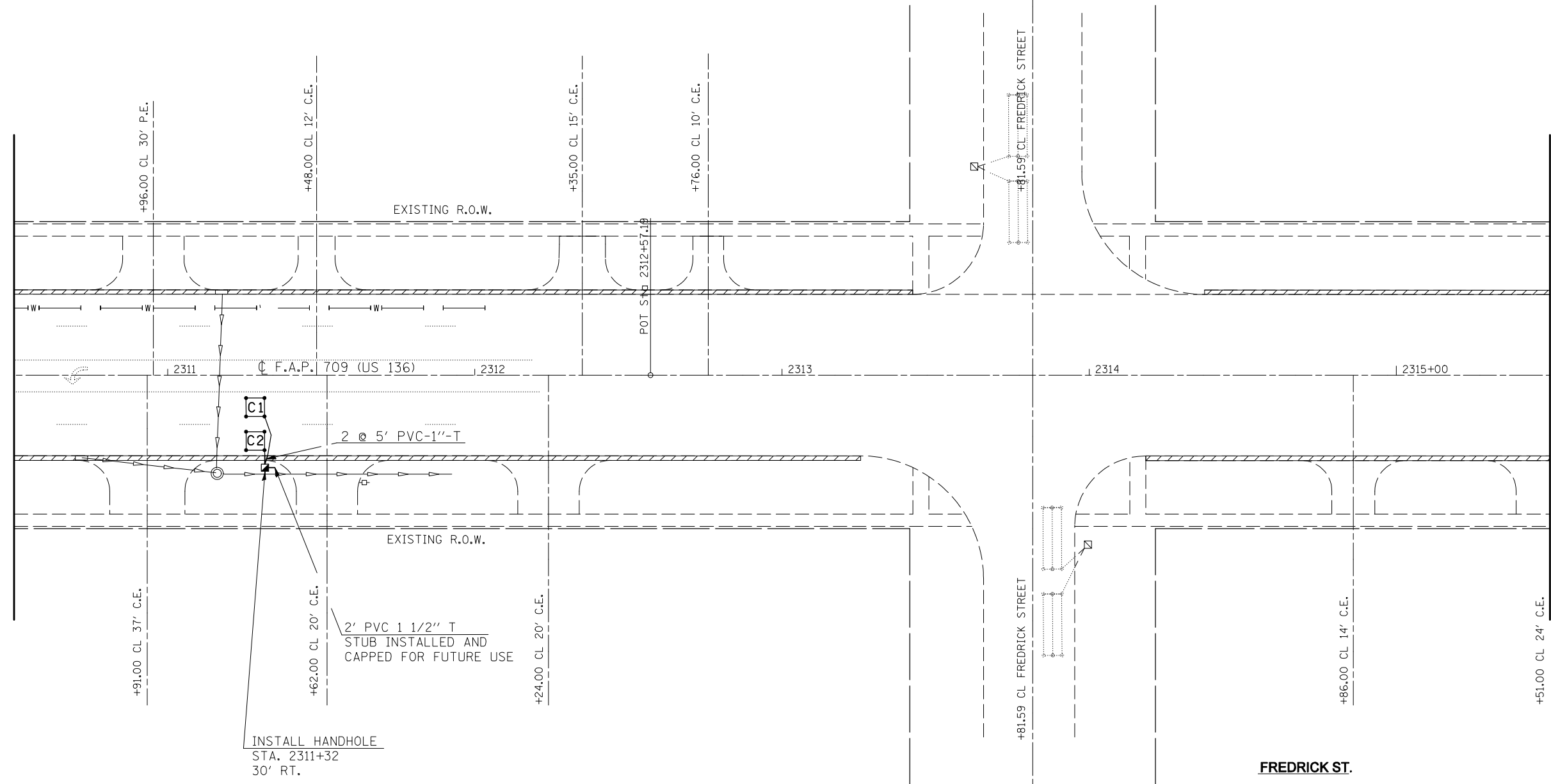

COLD MILLING (SPECIAL)

DETECTOR LOOP CHART				
U.S. 136 & Fredrick St.				
Loop	Length	Width	Number of Turns	Delay (sec.)
C1, C2	6'	6'	5	
D1, D2	6'	6'	5	

FREDRICK ST.	
DETECTOR LOOP, TYPE 1	128 FT.
HANDHOLE	2 EA.
CONDUIT IN TRENCH 1" PVC	20 FT.
CONDUIT IN TRENCH 1 1/2" PVC	4 FT.
TRENCH & BACKFILL - ELECT.	24 FT.

SEC. 2, T21N, R9E

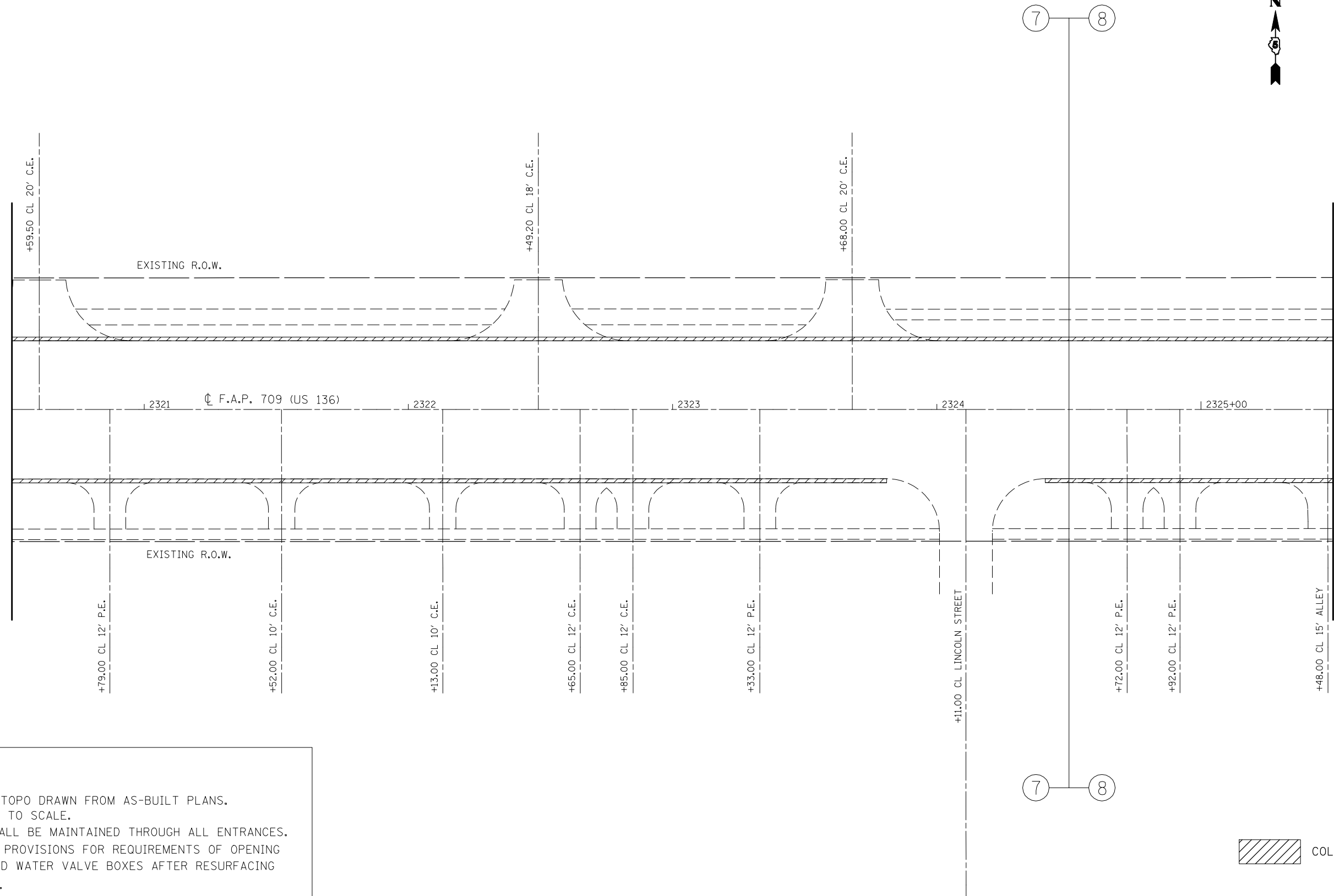

NOTES:

1. PLAN SHEET TOPO DRAWN FROM AS-BUILT PLANS. DRAWING NOT TO SCALE.
2. DRAINAGE SHALL BE MAINTAINED THROUGH ALL ENTRANCES.
3. SEE SPECIAL PROVISIONS FOR REQUIREMENTS OF OPENING MANHOLES AND WATER VALVE BOXES AFTER RESURFACING IS COMPLETE.

COLD MILLING (SPECIAL)

FILE NAME =	USER NAME = hoganbj	DESIGNED - BJM	REVISED -	STATE OF ILLINOIS DEPARTMENT OF TRANSPORTATION	PLAN SHEETS	F.A.P. RTE. 709	SECTION (113R/RS-1)	COUNTY CHAMPAIGN	TOTAL SHEETS 65	SHEET NO. 46		
ct:\pw\work\PWIDOT\HOGANBJ\d0104446\70177\sheets.dgn	PLOT SCALE = 40.0000' / IN.	DRAWN - BJH	REVISED -			SCALE: 1" = 20'	SHEET NO. 11 OF 20 SHEETS	STA. 2320+50 TO STA. 2325+50	CONTRACT NO. 70117			
	PLOT DATE = 1/29/2010	CHECKED -	REVISED -			FED. ROAD DIST. NO. ILLINOIS FED. AID PROJECT						
		DATE - 1/21/2010	REVISED -									

NOTES:

1. PLAN SHEET TOPO DRAWN FROM AS-BUILT PLANS. DRAWING NOT TO SCALE.
2. DRAINAGE SHALL BE MAINTAINED THROUGH ALL ENTRANCES.
3. SEE SPECIAL PROVISIONS FOR REQUIREMENTS OF OPENING MANHOLES AND WATER VALVE BOXES AFTER RESURFACING IS COMPLETE.

SEC. 2, T21N, R9E

EXIST. CURVE DATA
 PI STA. = 2330+80.00
 Δ = 45° 00' 30" (LT)
 D = 5° 43' 51"
 R = 999.76'
 T = 414.20'
 L = 785.37'
 E = 82.41'
 P.C. STA. = 2326+65.80
 P.T. STA. = 2334+51.17

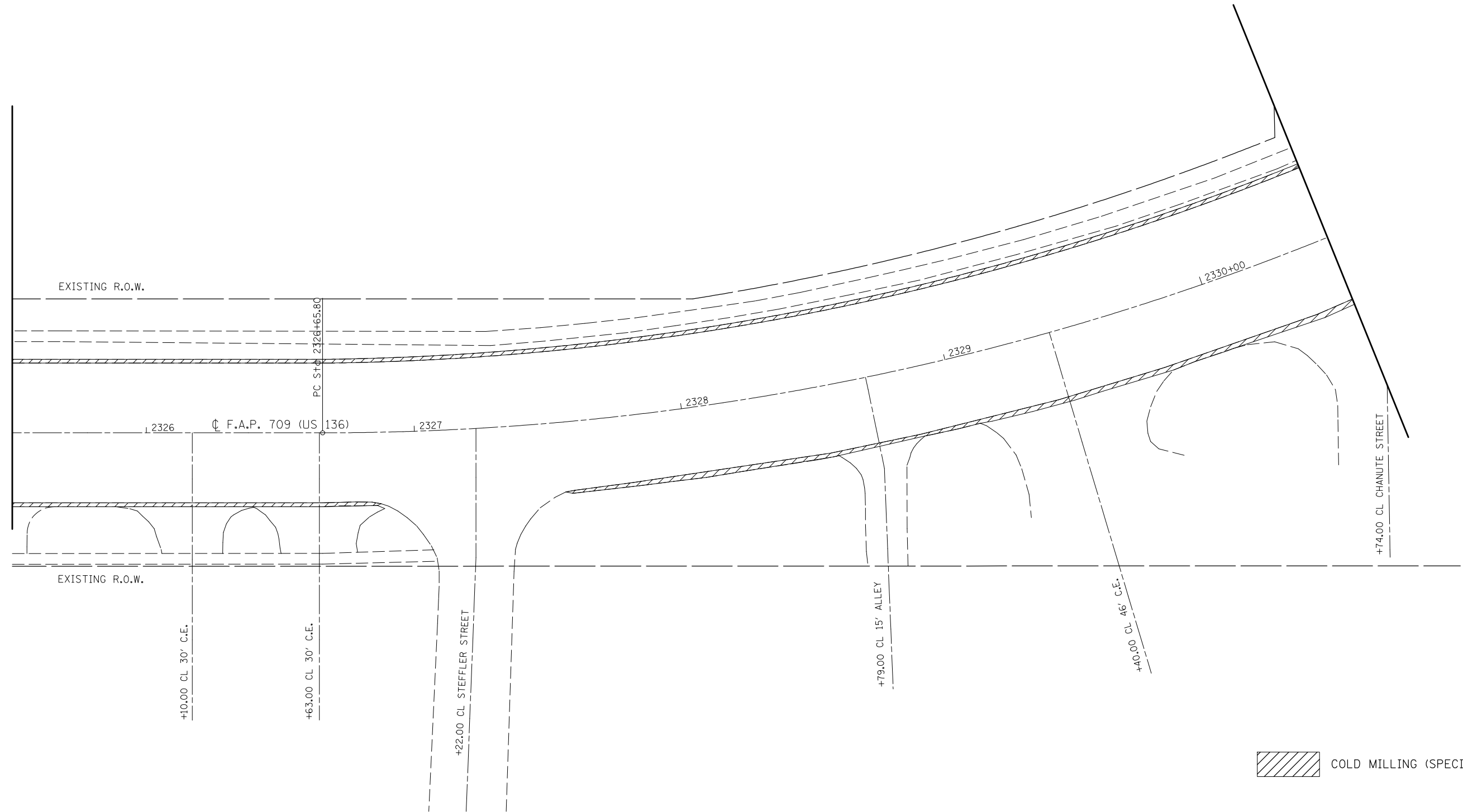

 COLD MILLING (SPECIAL)

FILE NAME = c:\pwork\work\PWIDOT\HOGANBJ\d0104446\7017\sheets.dgn	USER NAME = hoganbj	DESIGNED - BJM	REVISED -
PLOT SCALE = 40.0000' / IN.	CHECKED - BJH	DRAWN - BJH	REVISED -
PLOT DATE = 1/29/2010	DATE - 1/21/2010	REVISOR -	REVISED -

STATE OF ILLINOIS
 DEPARTMENT OF TRANSPORTATION

PLAN SHEETS

SCALE: 1" = 20' SHEET NO. 12 OF 20 SHEETS STA. 2325+50 TO STA. 2330+50

F.A.P. RTE.	SECTION	COUNTY	TOTAL SHEETS	SHEET NO.
709	(113)RS-1	CHAMPAIGN	65	47
FED. ROAD DIST. NO. ILLINOIS FED. AID PROJECT			CONTRACT NO. 70117	

SEC. 2, T21N, R9E

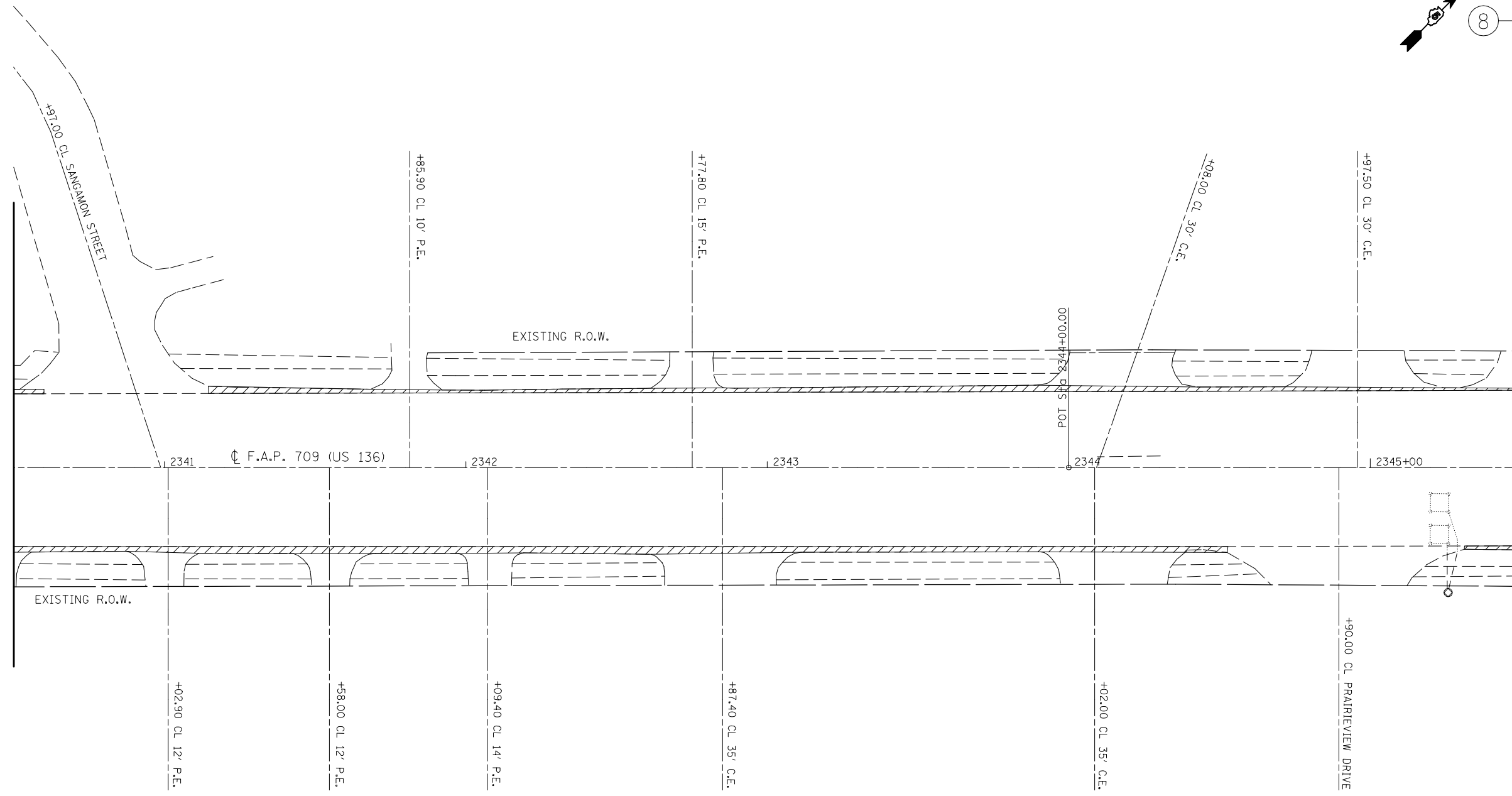
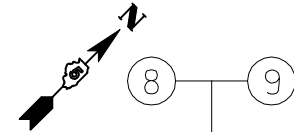

NOTES:

1. PLAN SHEET TOPO DRAWN FROM AS-BUILT PLANS. DRAWING NOT TO SCALE.
2. DRAINAGE SHALL BE MAINTAINED THROUGH ALL ENTRANCES.
3. SEE SPECIAL PROVISIONS FOR REQUIREMENTS OF OPENING MANHOLES AND WATER VALVE BOXES AFTER RESURFACING IS COMPLETE.

COLD MILLING (SPECIAL)

FILE NAME = c:\pw\work\p\dot\hoganbj\d0104446\7017	USER NAME = hoganbj sheets.dgn	DESIGNED - BJM	REVISED -	STATE OF ILLINOIS DEPARTMENT OF TRANSPORTATION	PLAN SHEETS	F.A.P. RTE. 709	SECTION (113RRS-1)	COUNTY CHAMPAIGN	TOTAL SHEETS 65	SHEET NO. 50			
PLOT SCALE = 40.0000' / IN.						SCALE: 1" = 20'		SHEET NO. 15 OF 20 SHEETS		STA. 2340+50 TO STA. 2345+50		CONTRACT NO. 70117	
PLOT DATE = 1/29/2010						DATE - 1/21/2010		FED. ROAD DIST. NO.		ILLINOIS FED. AID PROJECT			

SEC. 2, T21N, R9E

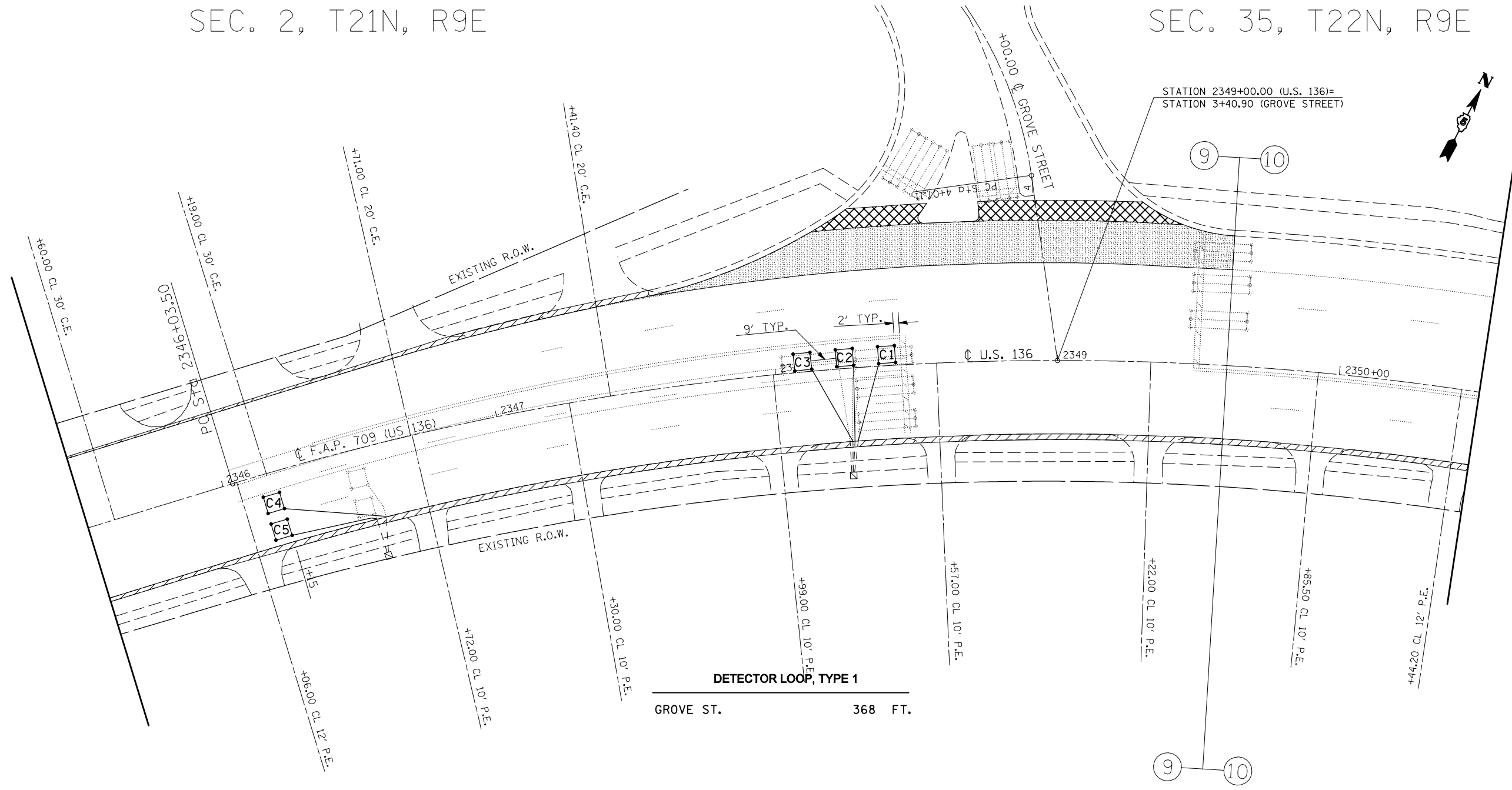

SEC. 35, T22N, R9E



DETECTOR LOOP, TYPE 1
GROVE ST. 368 FT.

DETECTOR LOOP CHART				
U.S. 136 & Grove St.				
Loop	Length	Width	Number of Turns	Delay (sec.)
C1, C2, C3	6'	6'	4	
C4, C5, D1, D2	6'	6'	5	

EXIST. CURVE DATA
 PI STA. = 2350+14.70
 $\Delta = 44^\circ 43' 46''$ (RT)
 $D = 5^\circ 44' 00''$
 $R = 999.39'$
 $T = 411.20'$
 $L = 780.16'$
 $E = 81.29'$
 $e = \text{----}$
 $T.R. = \text{----}$
 $S.E. \text{ RUN} = \text{----}$
 $P.C. \text{ STA.} = 2346+03.50$
 $P.T. \text{ STA.} = 2353+83.66$

-  INCIDENTAL SURFACING
-  COLD MILLING (SPECIAL)
-  PCC SURFACE REMOVAL, 2"

NOTES:

1. PLAN SHEET TOPO DRAWN FROM AS-BUILT PLANS. DRAWING NOT TO SCALE.
2. DRAINAGE SHALL BE MAINTAINED THROUGH ALL ENTRANCES.
3. SEE SPECIAL PROVISIONS FOR REQUIREMENTS OF OPENING MANHOLES AND WATER VALVE BOXES AFTER RESURFACING IS COMPLETE.

FILE NAME =	USER NAME = hoganbj	DESIGNED - BJM	REVISED -
ct:\pw\work\PWIDOT\HOGANBJ\d0104446\7017\sheets.dgn		DRAWN - BJH	REVISED -
PLOT SCALE = 40.0000' / IN.		CHECKED -	REVISED -
PLOT DATE = 1/29/2010		DATE - 1/21/2010	REVISED -

STATE OF ILLINOIS
DEPARTMENT OF TRANSPORTATION

PLAN SHEETS

SCALE: 1" = 20' SHEET NO. 16 OF 20 SHEETS STA. 2345+50 TO STA. 2350+50

F.A.P. RTE.	SECTION	COUNTY	TOTAL SHEETS	SHEET NO.
709	(113)RS-1	CHAMPAIGN	65	51
FED. ROAD DIST. NO.			ILLINOIS FED. AID PROJECT	
			CONTRACT NO. 70117	

SEC. 35, T22N, R9E

EXIST. CURVE DATA
 PI STA. = 2350+14.70
 $\Delta = 44^\circ 43' 46''$ (RT)
 D = $5^\circ 44' 00''$
 R = 999.39'
 T = 411.20'
 L = 780.16'
 E = 81.29'
 e = -----
 T.R. = -----
 S.E. RUN = -----
 P.C. STA. = 2346+03.50
 P.T. STA. = 2353+83.66

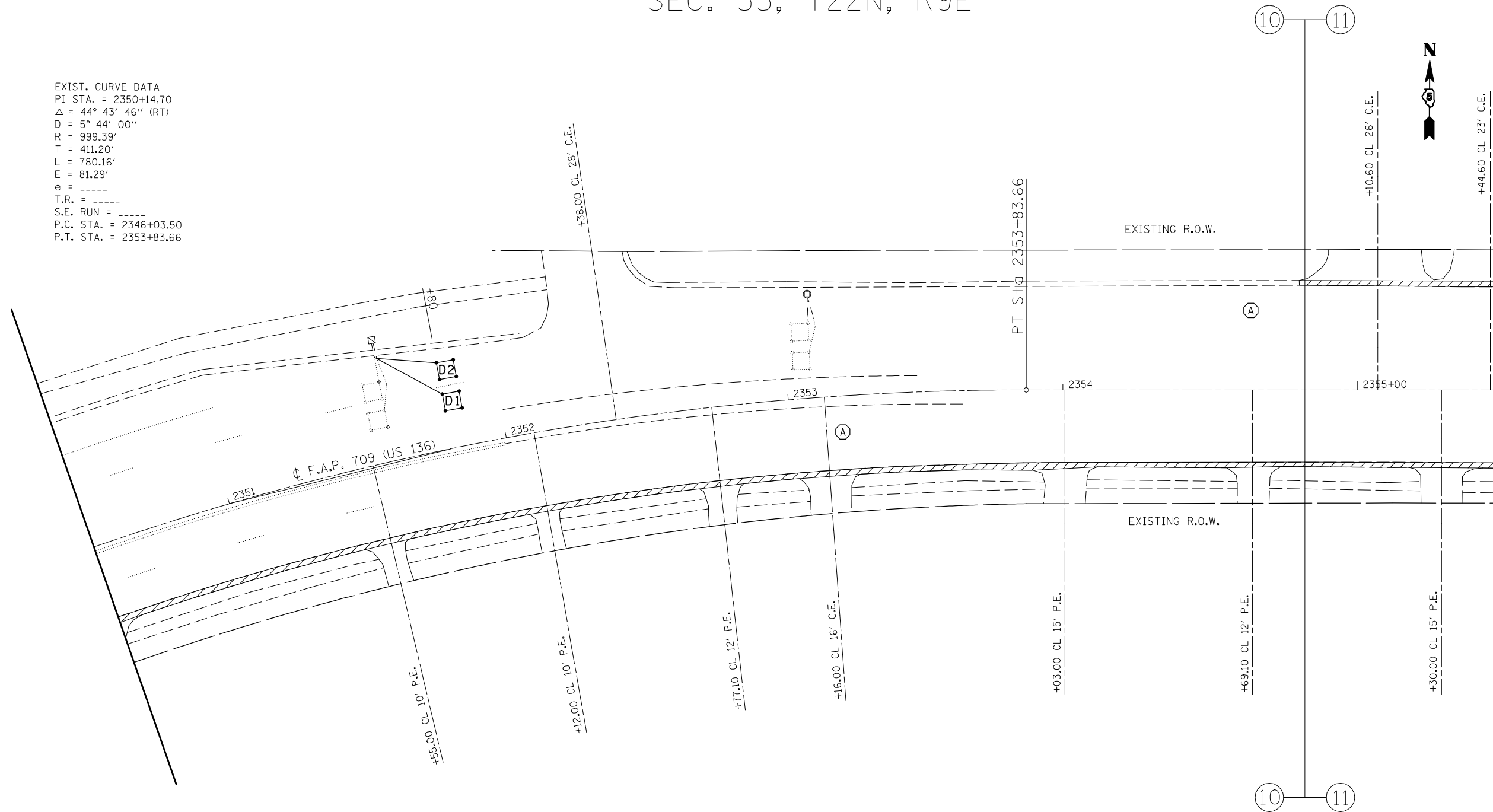

NOTES:

1. PLAN SHEET TOPO DRAWN FROM AS-BUILT PLANS. DRAWING NOT TO SCALE.
2. DRAINAGE SHALL BE MAINTAINED THROUGH ALL ENTRANCES.
3. SEE SPECIAL PROVISIONS FOR REQUIREMENTS OF OPENING MANHOLES AND WATER VALVE BOXES AFTER RESURFACING IS COMPLETE.

SEC. 2, T21N, R9E

 COLD MILLING (SPECIAL)

 MANHOLES TO BE ADJUSTED

FILE NAME = c:\pwork\work\PWIDOT\HOGANBJ\d0104446\7017\sheets.dgn	USER NAME = hoganbj	DESIGNED - BJM	REVISED -
PLOT SCALE = 40.0000' / IN.	CHECKED -	DRAWN - BJH	REVISED -
PLOT DATE = 1/29/2010	DATE - 1/21/2010		REVISED -

STATE OF ILLINOIS
 DEPARTMENT OF TRANSPORTATION

PLAN SHEETS

SCALE: 1" = 20' SHEET NO. 17 OF 20 SHEETS STA. 2350+50 TO STA. 2355+50

F.A.P. RTE.	SECTION	COUNTY	TOTAL SHEETS	SHEET NO.
709	(113)RS-1	CHAMPAIGN	65	52
FED. ROAD DIST. NO. ILLINOIS FED. AID PROJECT			CONTRACT NO. 70117	

SEC. 35, T22N, R9E

SEC. 36, T22N, R9E

STATION EQUATION:
 POT Sta 2362+39.04 BK =
 POT Sta 100+00.00 AH

NOTES:
 1. PLAN SHEET TOPO DRAWN FROM AS-BUILT PLANS. DRAWING NOT TO SCALE.
 2. DRAINAGE SHALL BE MAINTAINED THROUGH ALL ENTRANCES.
 3. SEE SPECIAL PROVISIONS FOR REQUIREMENTS OF OPENING MANHOLES AND WATER VALVE BOXES AFTER RESURFACING IS COMPLETE.

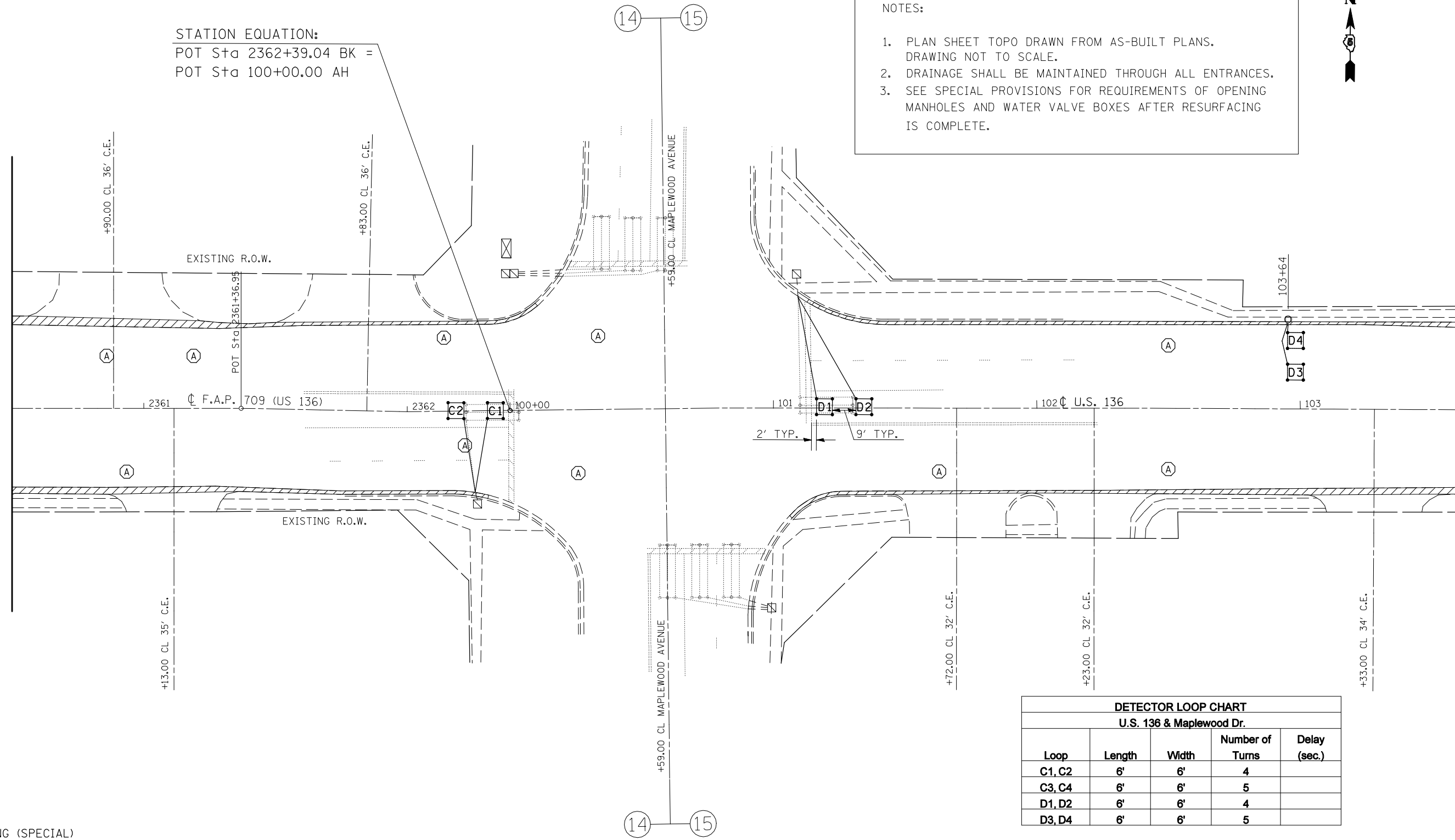

DETECTOR LOOP CHART				
U.S. 136 & Maplewood Dr.				
Loop	Length	Width	Number of Turns	Delay (sec.)
C1, C2	6'	6'	4	
C3, C4	6'	6'	5	
D1, D2	6'	6'	4	
D3, D4	6'	6'	5	

DETECTOR LOOP, TYPE 1
 MAPLEWOOD DR. 373 FT.

COLD MILLING (SPECIAL)

MANHOLES TO BE ADJUSTED

SEC. 2, T21N, R9E

SEC. 1, T21N, R9E

FILE NAME =	USER NAME = hoganbj	DESIGNED - BJM	REVISED -
ct:\pw\work\PWIDOT\HOGANBJ\d0104446\7017\sheets.dgn		DRAWN - BJH	REVISED -
	PLOT SCALE = 40.0000' / IN.	CHECKED -	REVISED -
	PLOT DATE = 1/29/2010	DATE - 1/21/2010	REVISED -

STATE OF ILLINOIS
 DEPARTMENT OF TRANSPORTATION

PLAN SHEETS

SCALE: 1" = 20' SHEET NO. 19 OF 20 SHEETS STA. 2360+50 TO STA. 103+60

F.A.P. RTE.	SECTION	COUNTY	TOTAL SHEETS	SHEET NO.
709	(113)RIS-1	CHAMPAIGN	65	54
FED. ROAD DIST. NO.			ILLINOIS FED. AID PROJECT	
			CONTRACT NO. 70117	

SEC. 36, T22N, R9E

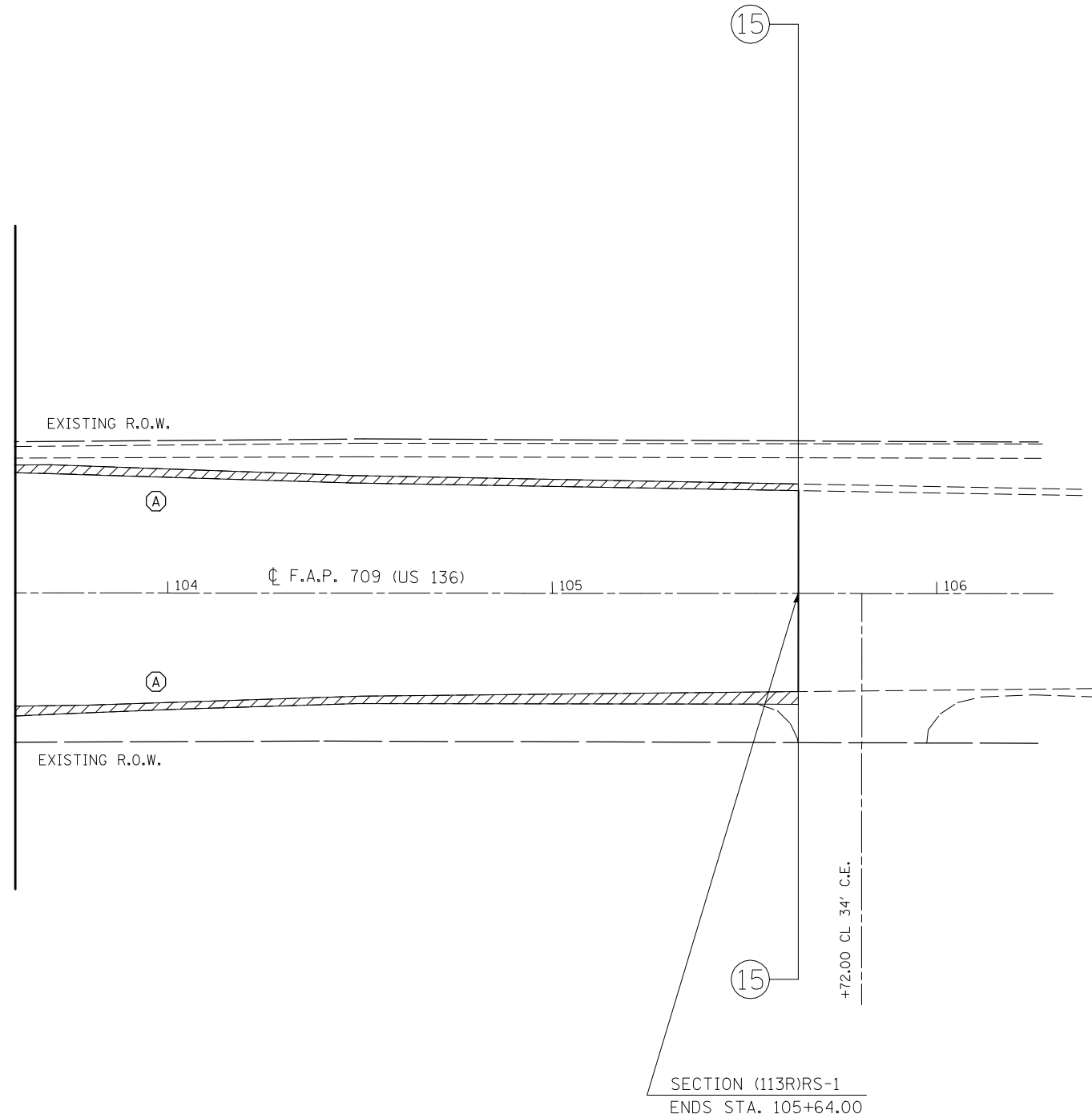

- NOTES:
1. PLAN SHEET TOPO DRAWN FROM AS-BUILT PLANS. DRAWING NOT TO SCALE.
 2. DRAINAGE SHALL BE MAINTAINED THROUGH ALL ENTRANCES.
 3. SEE SPECIAL PROVISIONS FOR REQUIREMENTS OF OPENING MANHOLES AND WATER VALVE BOXES AFTER RESURFACING IS COMPLETE.

 COLD MILLING (SPECIAL)

 MANHOLES TO BE ADJUSTED

SEC. 1, T21N, R9E

FILE NAME =	USER NAME = hoganbj	DESIGNED - BJM	REVISED -
ct:\pw\work\PWIDOT\HOGANBJ\d0104446\7017\sheets.dgn		DRAWN - BJH	REVISED -
	PLOT SCALE = 40.0000' / IN.	CHECKED -	REVISED -
	PLOT DATE = 1/29/2010	DATE - 1/21/2010	REVISED -

**STATE OF ILLINOIS
DEPARTMENT OF TRANSPORTATION**

PLAN SHEETS

SCALE: 1" = 20' SHEET NO. 20 OF 20 SHEETS STA. 103+60 TO STA. 106+00

F.A.P. RTE.	SECTION	COUNTY	TOTAL SHEETS	SHEET NO.
709	(113R)RS-1	CHAMPAIGN	65	55
FED. ROAD DIST. NO. ILLINOIS FED. AID PROJECT			CONTRACT NO. 70117	

MAINLINE BUTT JOINT & HMA RUNDOWNS

STATION	TO	STATION
2270+54.60		2270+84.60
2289+89.00		2290+19.00
2292+45.00		2292+75.00

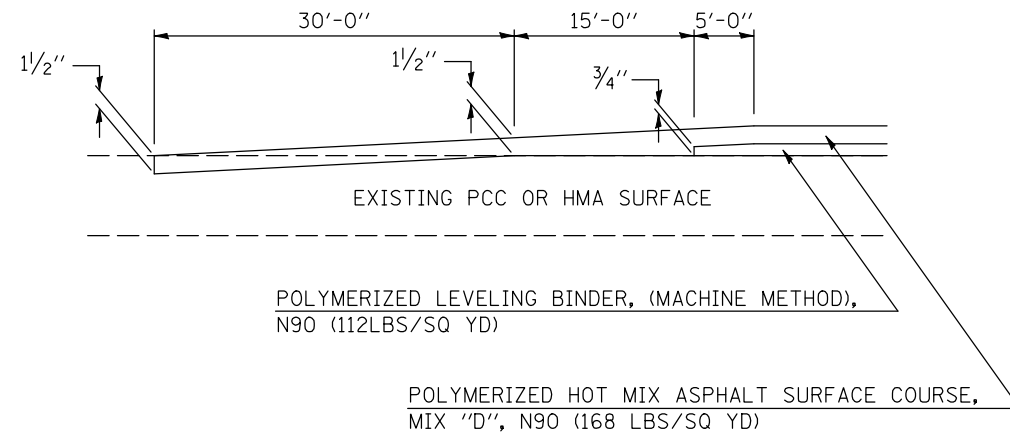

TANNER ST. BUTT JOINTS & HMA RUNDOWNS

NORTH APPROACH TANNER ST. 110' FROM FACE OF CURB U.S. 136
 SOUTH APPROACH TANNER ST. 146' FROM FACE OR CURB U.S. 136

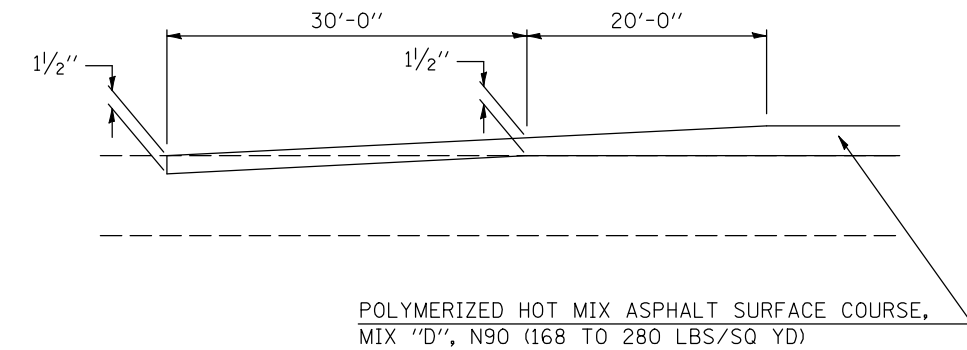

DETAIL FOR HMA RUNDOWN AT U.S. 45 AND END OF JOB

STATION	TO	STATION
2303+13.32		2303+23.32
2305+13.70		2305+23.70
105+54.00		105+64.00

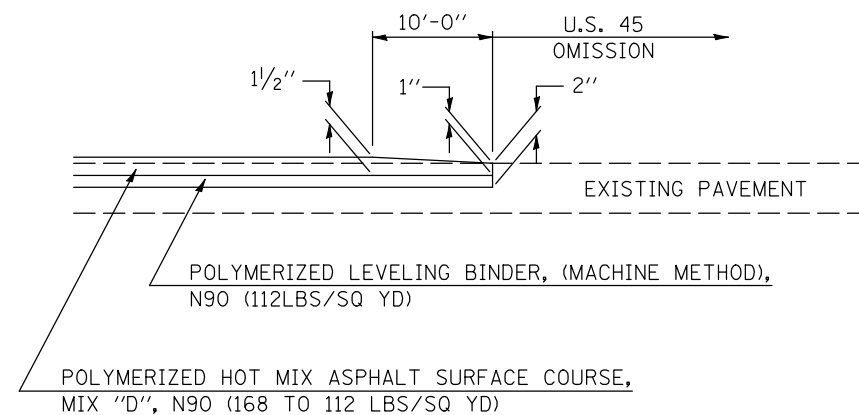

DETAIL OF CLASS D PATCHING

STATION	TO	STATION
2290+19.00		2292+45.00

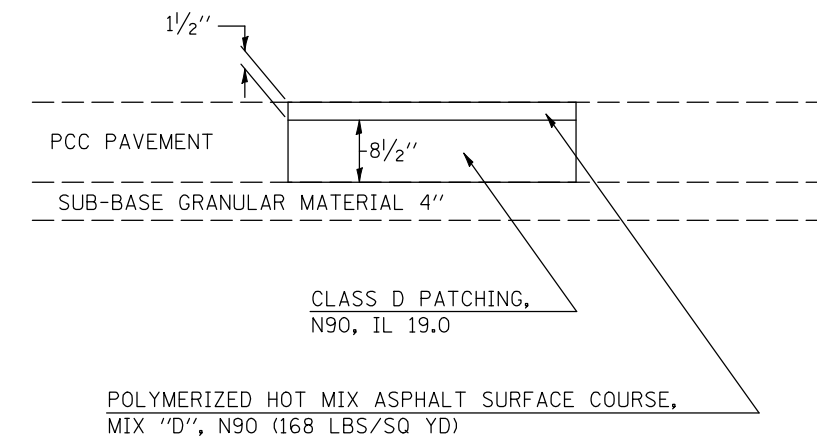

FILE NAME =	USER NAME = hoganbj	DESIGNED -	REVISED -
ct:\pw\work\PWIDOT\HOGANBJ\d0104446\D570117-sht-Details.dgn		DRAWN -	REVISED -
		CHECKED -	REVISED -
		DATE -	REVISED -

STATE OF ILLINOIS
 DEPARTMENT OF TRANSPORTATION

DETAILS			
SCALE:	SHEET NO.	OF SHEETS	STA. TO STA.

F.A.P. RTE.	SECTION	COUNTY	TOTAL SHEETS	SHEET NO.
709	(113R)RS-1	Champaign	65	56
CONTRACT NO.			65	70117
ILLINOIS FED. AID PROJECT				

PROJECTS WITHOUT RECONSTRUCTION

S.M.A.R.T. IMPROVEMENTS (POLICY RESURFACING; BDE 53-4.03; 1/2")

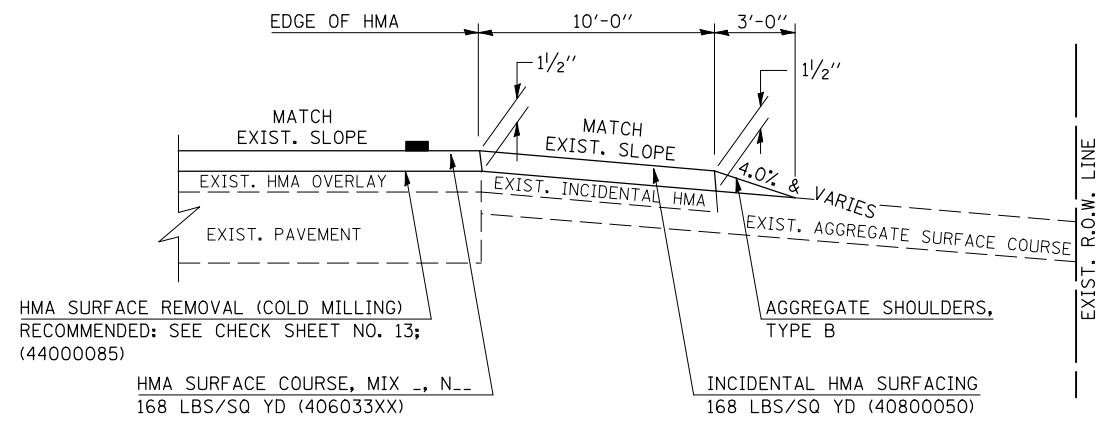

EXISTING AGGREGATE ENTRANCE

"3P" OR "3R" IMPROVEMENTS (POLICY RESURFACING; BDE 53-4.02; 2 1/4" OR 2 1/2" ON BARE CONCRETE)

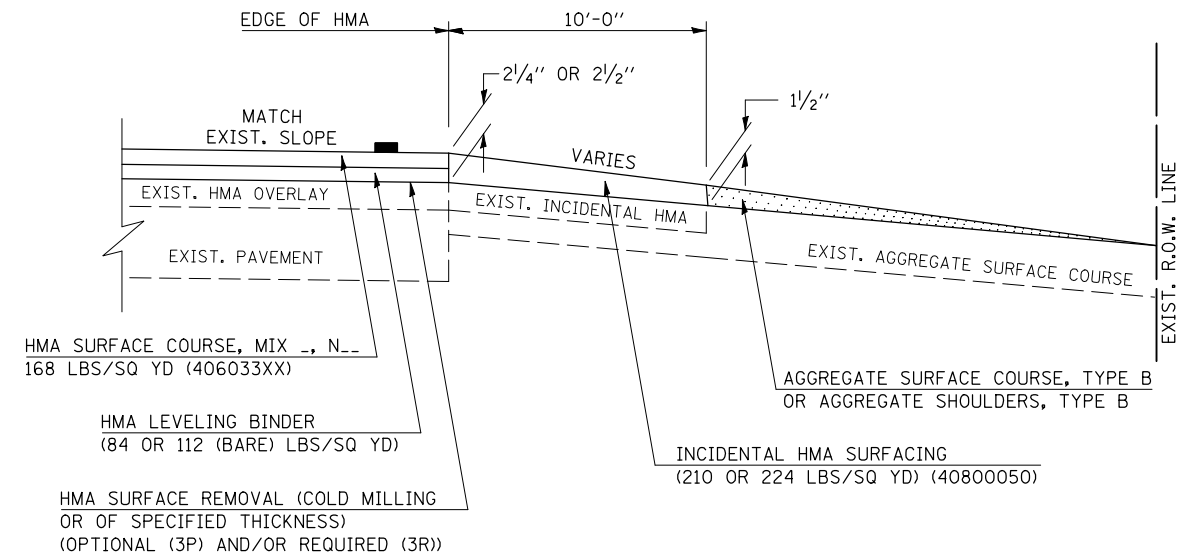

EXISTING AGGREGATE ENTRANCE

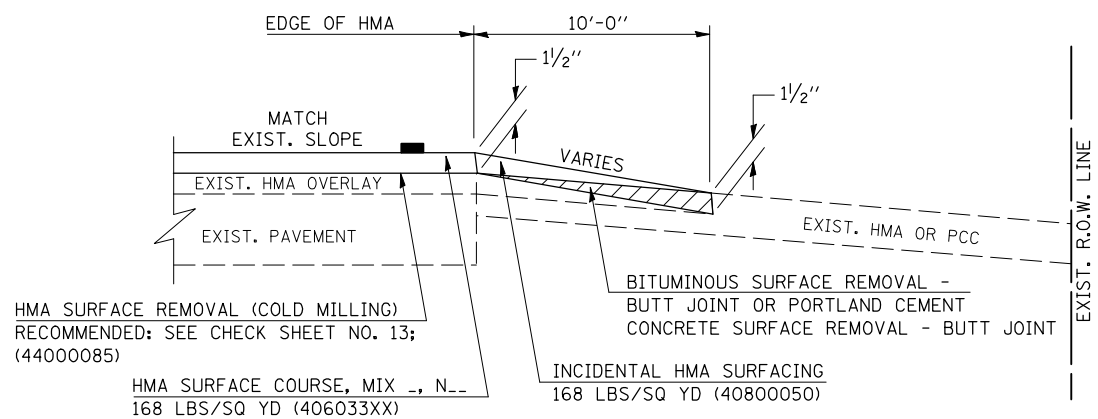

EXISTING HMA OR PCC ENTRANCE

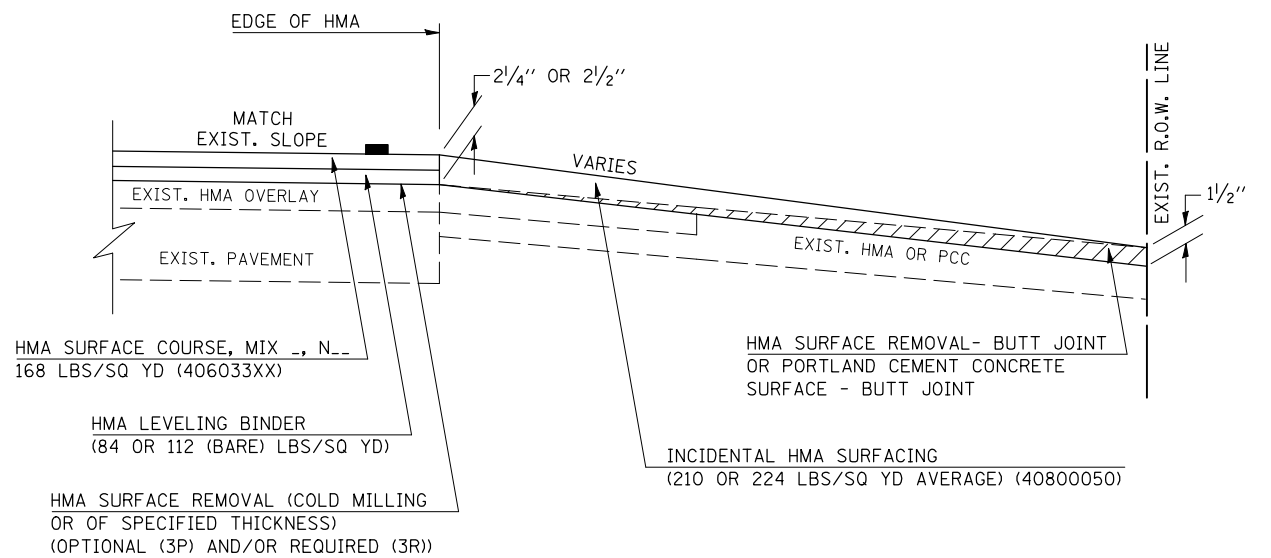

EXISTING HMA OR PCC ENTRANCE

Note: All dimensions are in INCHES
(millimeters) unless otherwise shown.

DISTRICT 5 DETAIL NO. 4080050C

FILE NAME = *FILEL*	USER NAME = *USER*	DESIGNED -	REVISED - 12/08/06 TJB
		DRAWN -	REVISED - 09/21/07 KAG
		CHECKED -	REVISED - 05/02/08 KJT
		DATE -	REVISED -

**STATE OF ILLINOIS
DEPARTMENT OF TRANSPORTATION**

**PRIVATE AND COMMERCIAL ENTRANCES
(NONCOMMERCIAL AND COMMERCIAL RURAL)**

SCALE: NA SHEET NO. 1 OF 2 SHEETS STA. TO STA.

F.A.P. RTE.	SECTION	COUNTY	TOTAL SHEETS	SHEET NO.
709	(113R/R5-1)	CHAMPAIGN	65	57
FED. ROAD DIST. NO. ILLINOIS FED. AID PROJECT			CONTRACT NO. 70117	

PROJECTS WITH RECONSTRUCTION

(3R IMPROVEMENTS)

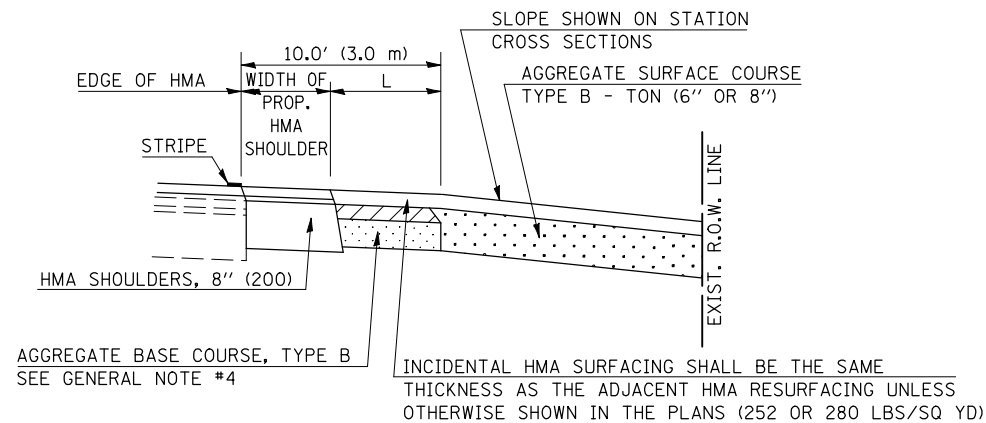
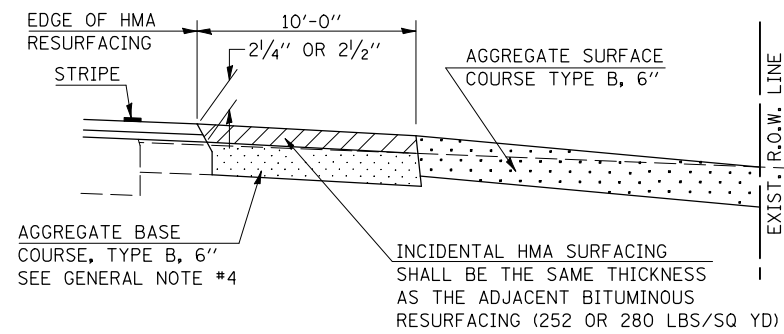
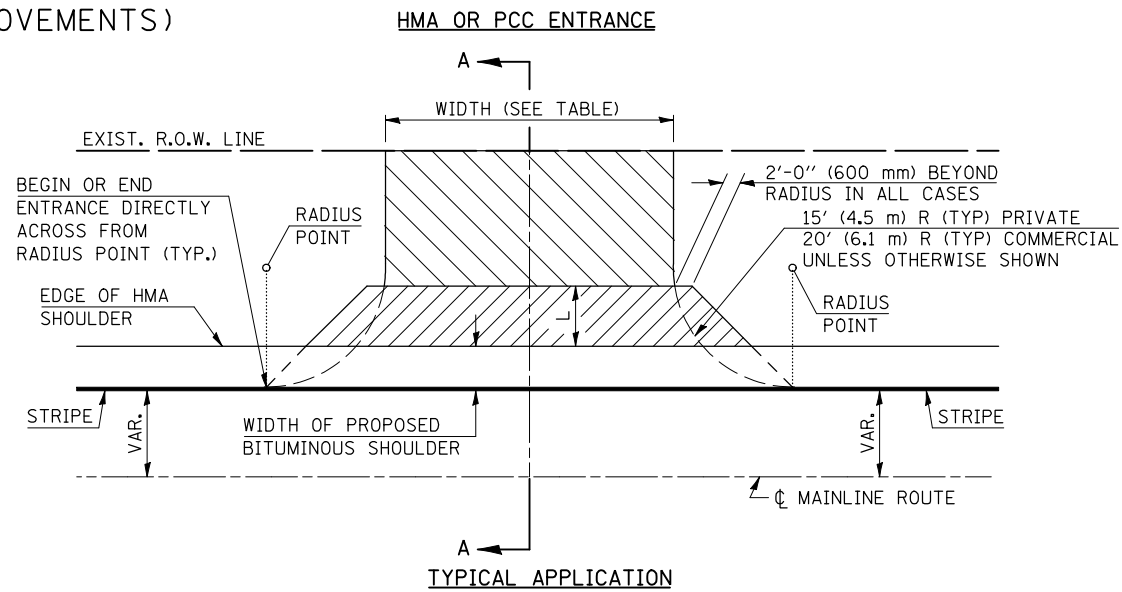
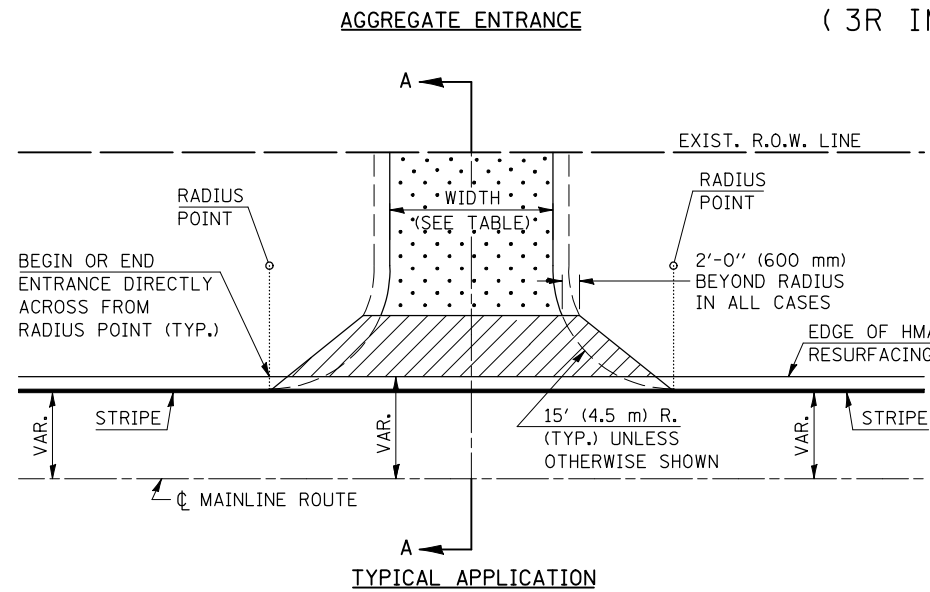

GENERAL NOTES

1. THE EXISTING SURFACE SHALL BE PREPARED IN ACCORDANCE WITH SECTION 408 OF THE STANDARD SPECIFICATIONS.
2. ANY NECESSARY WORK BEHIND THE HMA SHOULDER OR THE INCIDENTAL HMA SURFACING SHALL BE AS SHOWN IN THE PLANS AND/OR AS DIRECTED BY THE ENGINEER.
3. EARTH EXCAVATION REQUIRED FOR THE CONSTRUCTION OF THE AGGREGATE SURFACE COURSE SHALL BE INCLUDED IN THE COST OF AGGREGATE SURFACE COURSE.
4. AGGREGATE BASE COURSE, TYPE B, 6" (150 mm) MIN. SHALL BE USED WHERE IN THE OPINION OF THE ENGINEER THERE IS NOT SUFFICIENT BASE MATERIAL FOR THE PROPOSED ENTRANCES. THIS MATERIAL SHALL GENERALLY BE USED TO WIDEN ANY EXISTING RETURN OR TO CONSTRUCT NEW ENTRANCES WHERE NONE NOW EXISTS.
5. THE AGGREGATE BASE COURSE SHALL BE CONSTRUCTED 12" (300 mm) WIDER THAN THE SURFACE DIMENSIONS AS SHOWN ABOVE.
6. EXISTING FIELD ENTRANCES OF AGGREGATE OR EARTH WITH NO HMA APRON SHALL NOT RECEIVE A NEW HMA APRON WITHOUT PROPER APPROVAL THROUGH THE BUREAU OF OPERATIONS "POLICY ON PERMITS FOR ACCESS DRIVEWAYS TO STATE HIGHWAYS".
7. TO ASSURE APPROPRIATE ACCESS POLICIES ARE FOLLOWED ALL NEW ACCESS SHALL BE APPLIED FOR THROUGH THE BUREAU OF OPERATIONS PERMIT APPLICATION PROCESS. PLAN PREPARATION MEMORANDUMS 40-09 AND 40-11 ALONG WITH DISTRICT CONSTRUCTION MEMORANDUM 03/14 DISCUSS THIS PROCEDURE.

RURAL ENTRANCE DESIGN STANDARDS (PPM 40-09)															
DESIGN ELEMENT	NEW CONSTRUCTION & 3R with RECONSTRUCTION									3R w/out RECONSTRUCTION, 3P, SMART & CM					
	NONCOMMERCIAL						COMMERCIAL			NONCOMMERCIAL			COMMERCIAL		
	PRIVATE & FIELD			FIELD W/ FARM IMPLEMENTS			min.	des.	max.	PRIVATE & FIELD		COMMERCIAL			
	min.	des.	max.	min.	max.	min.	des.	max.	min.	des.	max.	min.	des.	max.	
SURFACE WIDTH (FT)	12, 16, 24, 24, 30						1 LANE, 1 WAY			resurface existing configuration; existing hma or pcc entrances shall have "butt joints" constructed; existing aggregate or earth entrances shall have the continuation of aggregate shoulders placed behind them					
							14	16	24						
RADIUS (FT)	15, 25, 40, 30						2 LANE, 2 WAY			taper from hma resurfacing thickness (2 1/2", 2 1/4" or 1 1/2") to 1 1/2" for "butt joints" and to minimize aggregate shoulder					
							24	30	35						
SHOULDER WIDTH (FT)	2						1	3		if applicable use items: Preparation of Base & Aggregate Base Repair; see PPM 30-02					
SHOULDER SLOPE (%)	2						2	4		6 or 8					
ENTRANCE GRADE (%)	0						0	2 to 5		8 or 10					
SIDE SLOPE (FT)	1:10						1:10	1:6		1:4					
SURFACE TYPE															
INCIDENTAL HMA SURFACING (INCH)	2						3 or 4								
AGGREGATE SURFACE COURSE, TYPE B (INCH)	6						8								
PCC DRIVEWAY PAVEMENT (INCH)	6									6 or 8					

Note: All dimensions are in INCHES (millimeters) unless otherwise shown.

DISTRICT 5 DETAIL NO. 4080050C

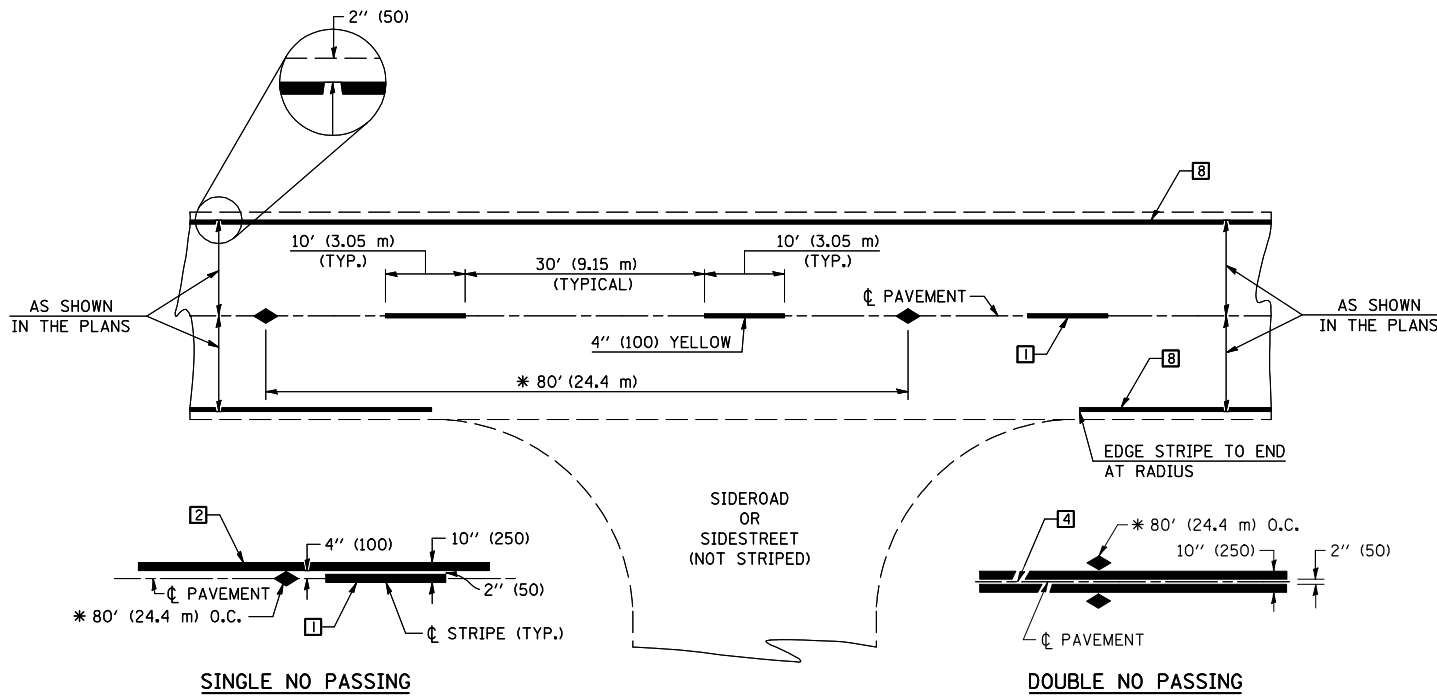

* REDUCE TO 40' (12.2 m) O.C. ON CURVES WITH POSTED OR ADVISORY SPEEDS OF 45 mph (70 km/h) OR LESS.

TWO LANE/TWO WAY

TYPICAL PAVEMENT MARKING LEGEND

- 1 4" (100) SKIP-DASH (YELLOW)
- 2 4" (100) SOLID (YELLOW)
- 3 12" (300) DIAGONAL (YELLOW)
- 4 4" (100) DOUBLE YELLOW (NARROW)
- 5 RESERVED
- 6 RESERVED
- 7 4" (100) SKIP-DASH (WHITE)
- 8 4" (100) SOLID (WHITE)
- 9 12" (300) DIAGONAL (WHITE)
- 10 6" (150) SOLID (WHITE)
- 11 24" (600) STOP BAR (WHITE)
- 12 8" (200) SOLID (WHITE)
- 13 4" (100) LANE LINE EXTENSIONS (WHITE)
- 14 4" (100) PARKING WHITE

TYPICAL PAVEMENT MARKERS LEGEND

- ◆ TWO-WAY AMBER MARKER
- ▶ ONE-WAY AMBER MARKER
- ▷ ONE-WAY CRYSTAL MARKER

RURAL LEFT TURN

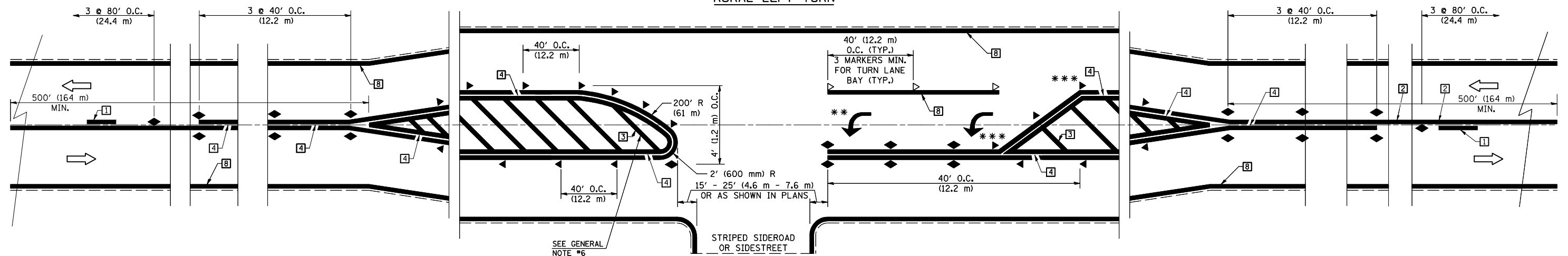

*** REDUCE SPACING IF NECESSARY TO ASSURE MARKERS AT CORNER POINTS.

** TURN ARROWS SHALL BE PLACED AS SHOWN ON SHEET #2.

Note: All dimensions are in INCHES (millimeters) unless otherwise shown.

DISTRICT 5 DETAIL NO. 7800AAA

FILE NAME =	USER NAME = #USER*	DESIGNED -	REVISED - 11/06
#FILEL#		DRAWN -	REVISED - 09/2009 - KJT
	PLOT SCALE = #SCALE#	CHECKED -	REVISED -
	PLOT DATE = #DATE#	DATE -	REVISED -

**STATE OF ILLINOIS
DEPARTMENT OF TRANSPORTATION**

**PAVEMENT MARKING AND MARKERS
(RURAL & URBAN APPLICATIONS)**

SCALE: SHEET NO. 1 OF 4 SHEETS STA. TO STA.

F.A.P. RTE.	SECTION	COUNTY	TOTAL SHEETS	SHEET NO.
709	(113)RS-1	CHAMPAIGN	65	59
FED. ROAD DIST. NO. ILLINOIS FED. AID PROJECT			CONTRACT NO. 70117	

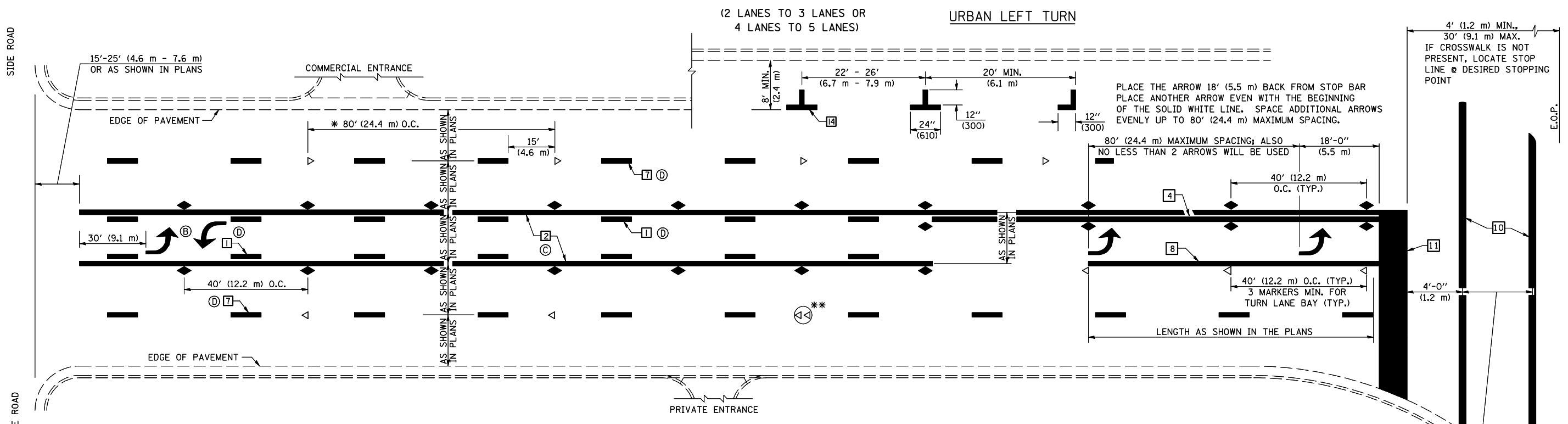

* REDUCE TO 40 FEET (12.2 METERS) ON CENTER ON CURVES WHERE ADVISORY SPEEDS ARE 10 MPH (15 km/h) LOWER THAN POSTED SPEEDS.

** DOUBLE LANE LINE MARKERS SHALL BE SPECIFIED AND SPACED AS SHOWN IN HIGHWAY STANDARD 781001 FOR MULTI-LANE DIVIDED AND UNDIVIDED HIGHWAYS.

GENERAL NOTES:

- ⓑ TURN ARROW PAIRS SHALL BE PLACED AT 250' (75 m) INTERVALS AND SHALL BE EVENLY SPACED BETWEEN BOTH ENDS OF THE BIDIRECTIONAL LEFT TURN LANE.
- ⓒ THE SOLID YELLOW PAVEMENT MARKINGS [2] SHOULD GENERALLY START OR END NEAR THE RADIUS POINT OF EACH STREET RETURN EXCEPT WHERE ONE OR BOTH ENDS WOULD INCLUDE STOP BARS.
- ⓓ THE SKIP-DASH PAVEMENT MARKINGS [1] OR [7] SHOULD BE CENTERED BETWEEN BOTH ENDS OF EACH CITY BLOCK AND SHALL BE PLACED SO THEY LINE UP ACROSS FROM EACH OTHER. SEE EXAMPLE ON SHEET 2 OF 3.
- ⓔ USE LARGE ARROW SIZE FOR BOTH RURAL AND URBAN LOCATIONS. (SEE LAST PAGE OF SECTION 780x FOR SYMBOLS TABLE)

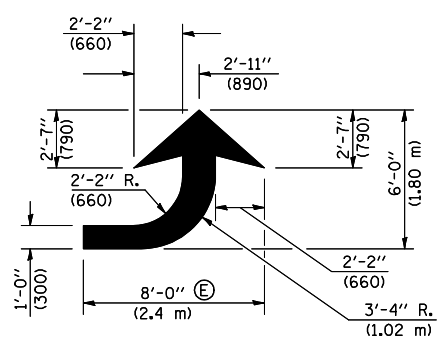

LEFT ARROW

REVERSE FOR RIGHT ARROW
AREA = 15.6 SQ. FT. (1.47 m²)
(WHITE)

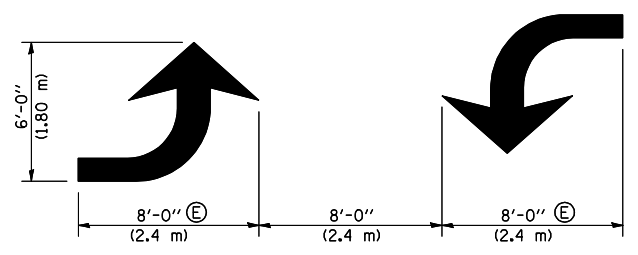

TYPICAL DOUBLE TURN ARROWS (WHITE)

BLOOMINGTON-NORMAL CITY LIMITS ONLY

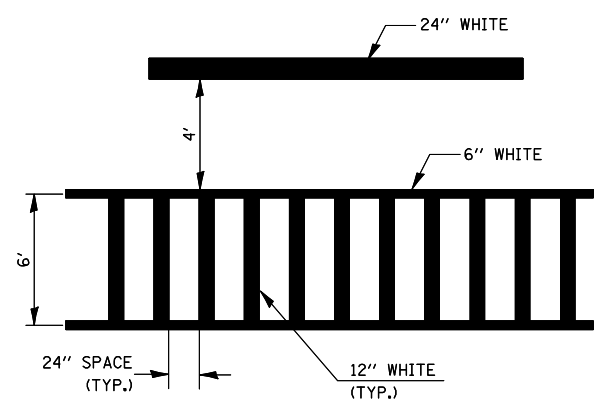

TYPICAL SPACING FOR CROSSWALKS & STOP BARS

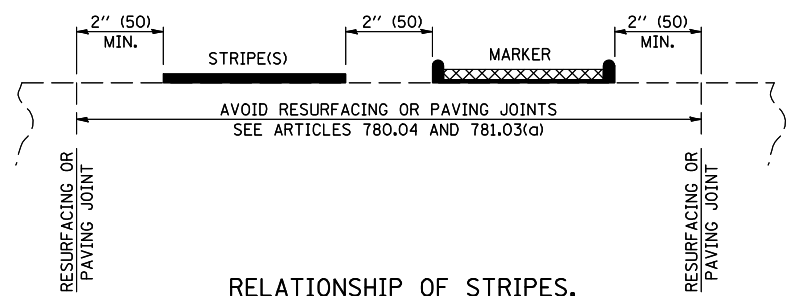

RELATIONSHIP OF STRIPES, MARKERS AND JOINTS

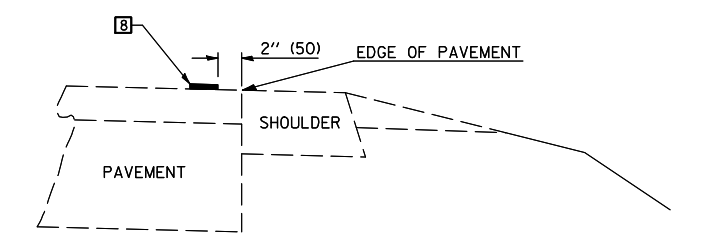

RELATIONSHIP OF EDGE LINE TO EDGE OF PAVEMENT (SAFETY SHOULDER OR PAVED SURFACE) SEE ARTICLE 780.04

CROSSWALK WIDTH 6'-0" (1.8 m) OR AS SHOWN IN THE PLANS

Note: All dimensions are in INCHES (millimeters) unless otherwise shown.

FILE NAME = #FILE#	USER NAME = #USER#	DESIGNED -	REVISED - 11/06
		DRAWN -	REVISED - 09/2009 - KJT
	PLOT SCALE = #SCALE#	CHECKED -	REVISED -
	PLOT DATE = #DATE#	DATE -	REVISED -

**STATE OF ILLINOIS
DEPARTMENT OF TRANSPORTATION**

**PAVEMENT MARKING AND MARKERS
(RURAL & URBAN APPLICATIONS)**

SCALE: SHEET NO. 2 OF 4 SHEETS STA. TO STA.

DISTRICT 5 DETAIL NO. 7800AAA

F.A.P. RTE.	SECTION	COUNTY	TOTAL SHEETS	SHEET NO.
709	(113)RS-1	CHAMPAIGN	65	60
FED. ROAD DIST. NO. ILLINOIS FED. AID PROJECT			CONTRACT NO. 70117	

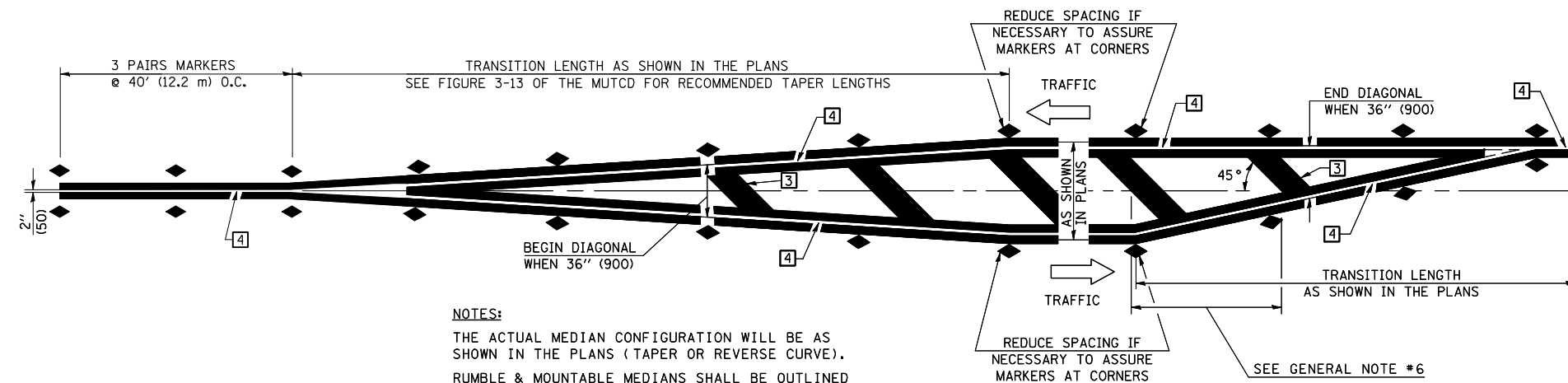

NOTES:
 THE ACTUAL MEDIAN CONFIGURATION WILL BE AS SHOWN IN THE PLANS (TAPER OR REVERSE CURVE).
 RUMBLE & MOUNTABLE MEDIANS SHALL BE OUTLINED WITH [2].

TYPICAL MEDIAN TRANSITIONS

GENERAL NOTES

1. WHEN MEDIANS ARE PRESENT, PAVEMENT MARKINGS ARE TO BE PLACED ADJACENT TO MEDIANS.
2. SOME OF THE INFORMATION INCLUDED WITH THIS DETAIL MAY NOT BE APPLICABLE TO THIS IMPROVEMENT.
3. PAVEMENT MARKINGS ARE TO BE EXTENDED THROUGH OMISSIONS WHEN APPLICABLE.
4. A STRIPING KEY IS AVAILABLE ELSEWHERE AND SHALL BE SHOWN WHERE THE QUANTITIES ARE LISTED.
5. FINAL PAVEMENT MARKINGS SHALL BE IN PLACE PRIOR TO PLACING ANY RAISED REFLECTIVE PAVEMENT MARKERS.
6. THE FOLLOWING CRITERIA SHALL BE USED FOR SELECTING THE DIAGONAL PAVEMENT MARKING SPACING,
 < 30 MPH USE 15' (< 50 km/h USE 4.5 m)
 30-45 MPH USE 20' (50-75 km/h USE 6.0 m)
 > 45 MPH USE 30' (> 75 km/h USE 9.0 m)

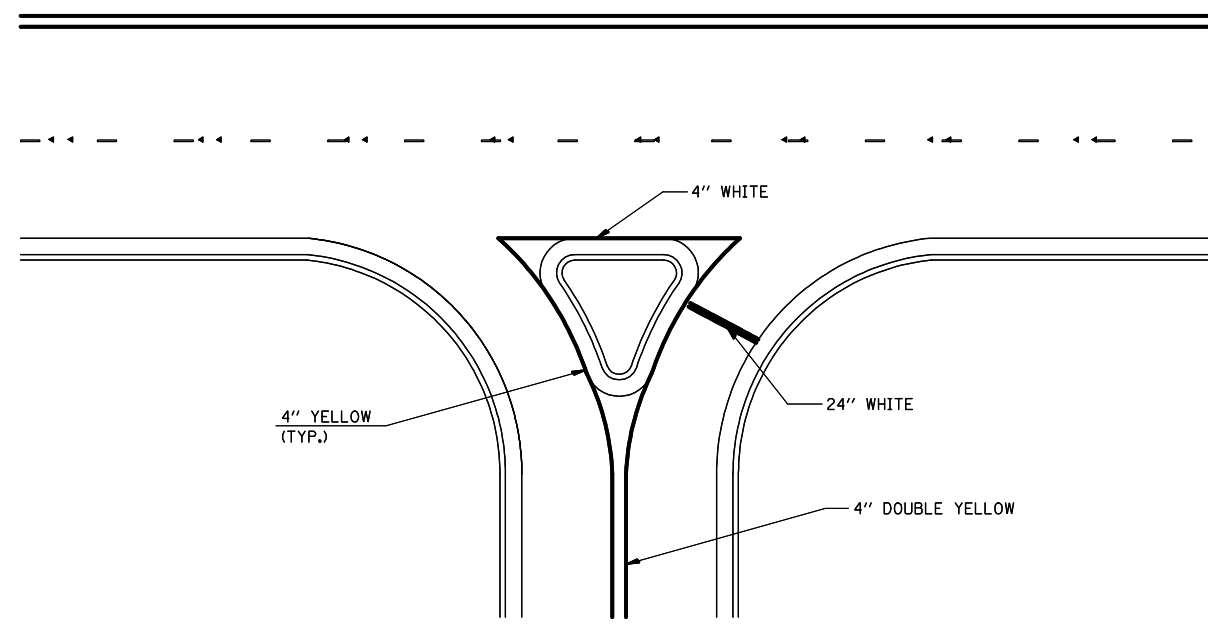

RIGHT IN - RIGHT OUT ACCESS

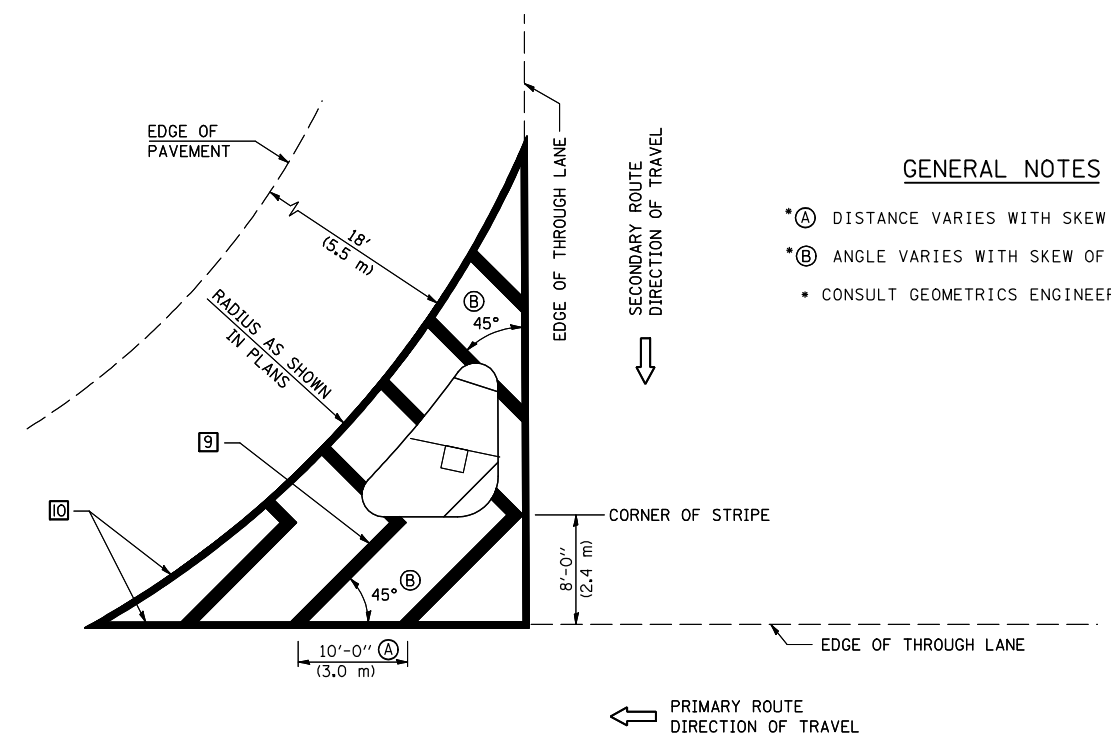

GENERAL NOTES

- *A DISTANCE VARIES WITH SKEW OF INTERSECTION.
- *B ANGLE VARIES WITH SKEW OF INTERSECTION.
- CONSULT GEOMETRICS ENGINEER

ISLAND

Note: All dimensions are in INCHES (millimeters) unless otherwise shown.

FILE NAME = #FILEL#	USER NAME = #USER#	DESIGNED -	REVISED - 11/06
		DRAWN -	REVISED - 09/2009 - KJT
	PLOT SCALE = #SCALE#	CHECKED -	REVISED -
	PLOT DATE = #DATE#	DATE -	REVISED -

**STATE OF ILLINOIS
 DEPARTMENT OF TRANSPORTATION**

**PAVEMENT MARKING AND MARKERS
 (RURAL & URBAN APPLICATIONS)**

SCALE: SHEET NO. 3 OF 4 SHEETS STA. TO STA.

DISTRICT 5 DETAIL NO. 7800AAA

F.A.P. RTE.	SECTION	COUNTY	TOTAL SHEETS	SHEET NO.
709	(113)RS-1	CHAMPAIGN	65	61
FED. ROAD DIST. NO. ILLINOIS FED. AID PROJECT			CONTRACT NO. 70117	

RAILROAD CROSSING WITH INTERCONNECT ONLY

RAILROAD CROSSING WITH INTERCONNECT AND PRE-SIGNALS

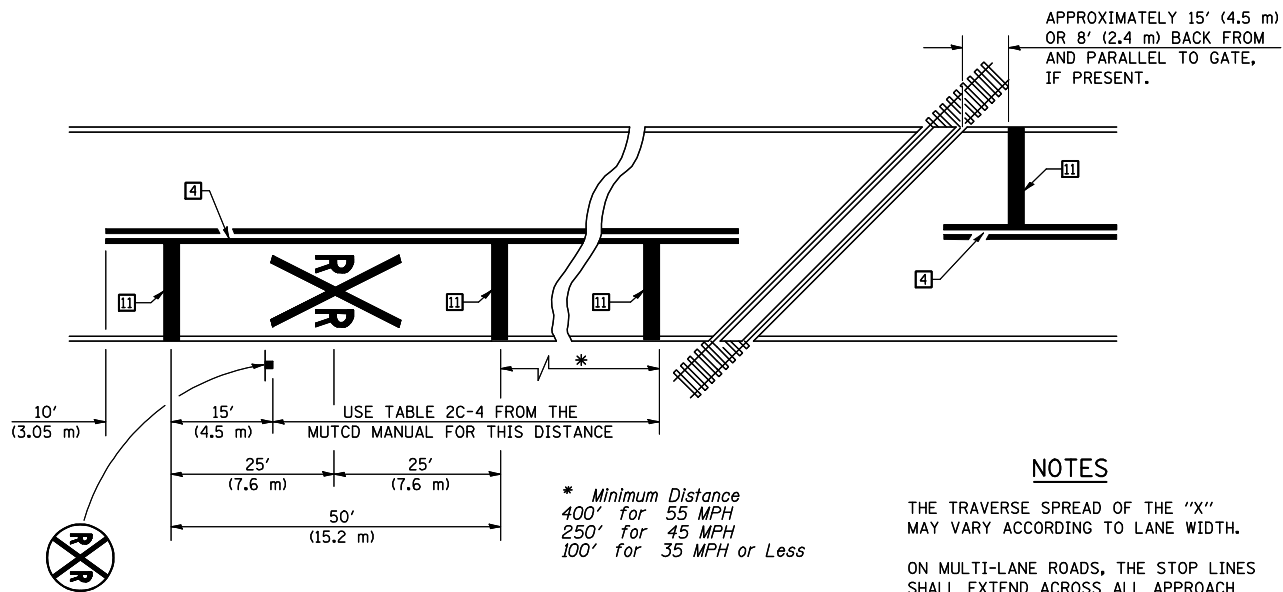

PAVEMENT MARKINGS AT RAILROAD-HIGHWAY GRADE CROSSING

NOTES

APPROXIMATELY 15' (4.5 m) OR 8' (2.4 m) BACK FROM AND PARALLEL TO GATE, IF PRESENT.

THE TRAVERSE SPREAD OF THE "X" MAY VARY ACCORDING TO LANE WIDTH.

ON MULTI-LANE ROADS, THE STOP LINES SHALL EXTEND ACROSS ALL APPROACH LANES AND SEPARATE RXR SYMBOLS SHALL BE PLACED ADJACENT TO EACH OTHER IN EACH LANE.

WHEN THE PAVEMENT MARKING SYMBOL IS USED, A PORTION OF THE SYMBOL SHOULD BE LOCATED DIRECTLY ADJACENT TO THE ADVANCE WARNING SIGN (W10-1) AS PLACED BY TABLE II-1, CONDITION B OF THE MUTCD.

* Minimum Distance
400' for 55 MPH
250' for 45 MPH
100' for 35 MPH or Less

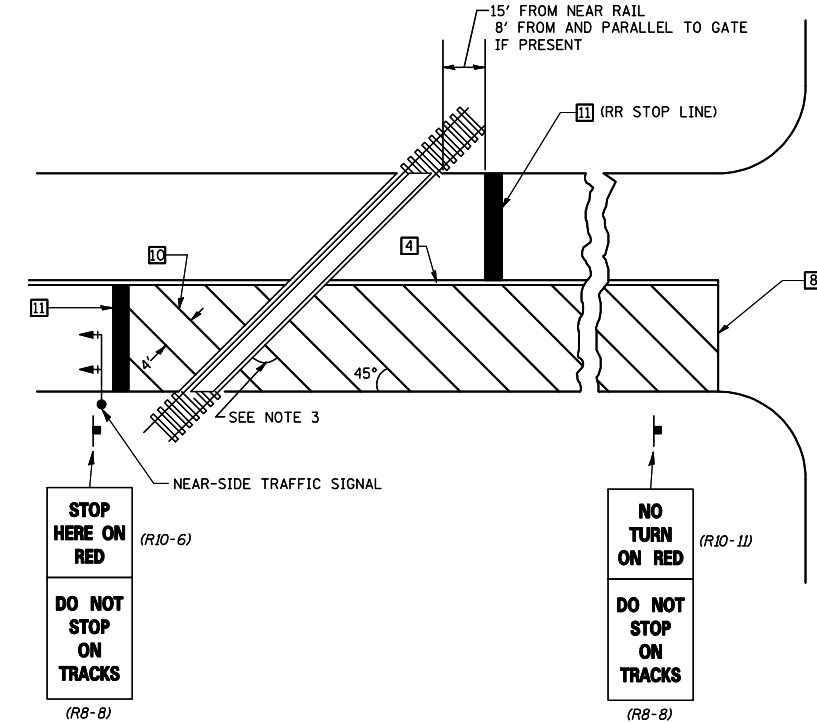
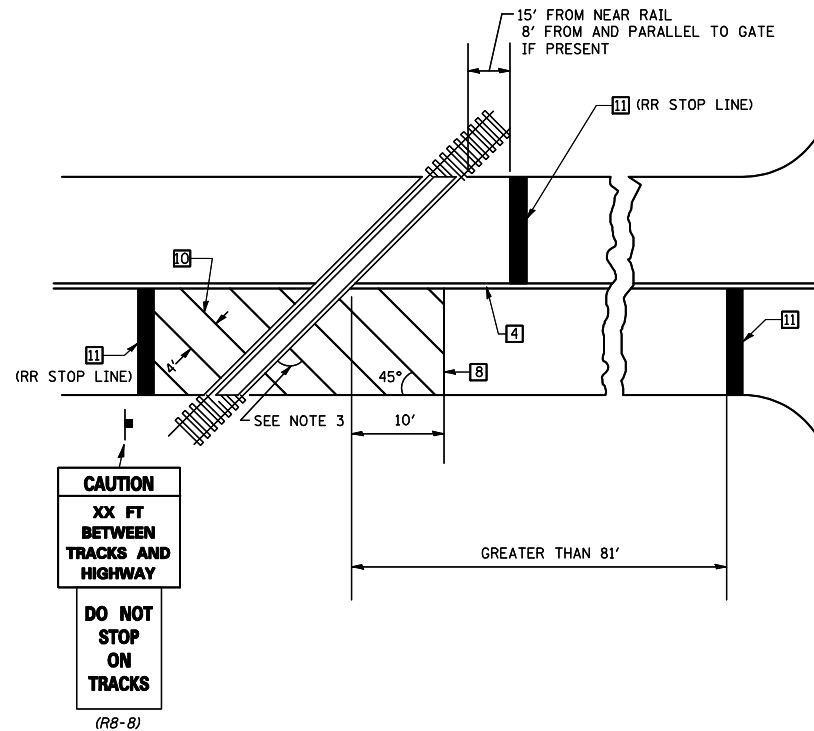

SUPPLEMENTAL PAVEMENT MARKING TREATMENT FOR RAILROAD-HIGHWAY GRADE CROSSING

GENERAL NOTES

- SUPPLEMENTAL PAVEMENT MARKINGS TO BE INSTALLED ONLY ON APPROACHES TO INTERSECTIONS CONTROLLED BY TRAFFIC SIGNALS WHICH ARE INTERCONNECTED WITH THE RAILROAD WARNING SIGNALS.
- EXTEND PAVEMENT MARKINGS TO THE INTERSECTION ONLY WHERE NEAR-SIDE TRAFFIC SIGNALS ARE USED.
- WHERE THE ANGLE BETWEEN THE DIAGONAL PAVEMENT MARKINGS AND THE TRACK WOULD BE LESS THAN 20°, THE PAVEMENT MARKINGS SHOULD BE PLACED IN THE OPPOSITE DIRECTION FROM THAT SHOWN.

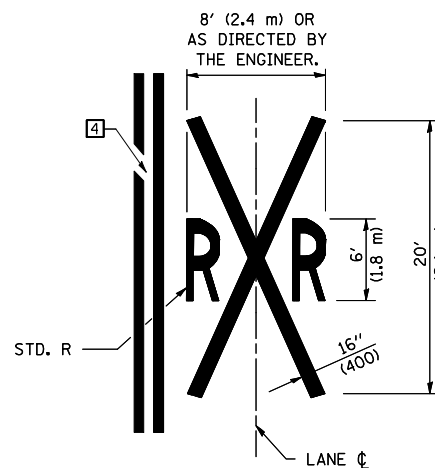

Note: All dimensions are in INCHES (millimeters) unless otherwise shown.

FILE NAME = \$FILEL\$	USER NAME = \$USER\$	DESIGNED -	REVISED - 11/06
		DRAWN -	REVISED - 09/2009 - KJT
	PLOT SCALE = \$SCALE\$	CHECKED -	REVISED -
	PLOT DATE = \$DATE\$	DATE -	REVISED -

STATE OF ILLINOIS
DEPARTMENT OF TRANSPORTATION

PAVEMENT MARKING AND MARKERS
(RURAL & URBAN APPLICATIONS)

SCALE: SHEET NO. 4 OF 4 SHEETS STA. TO STA.

DISTRICT 5 DETAIL NO. 7800AAAA

F.A.P. RTE.	SECTION	COUNTY	TOTAL SHEETS	SHEET NO.
709	(113)RS-1	CHAMPAIGN	65	62
FED. ROAD DIST. NO. ILLINOIS FED. AID PROJECT			CONTRACT NO. 70117	

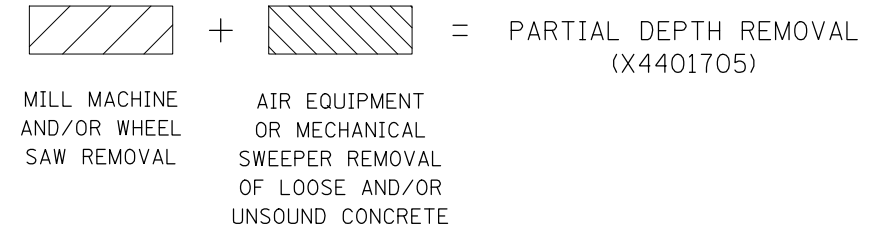
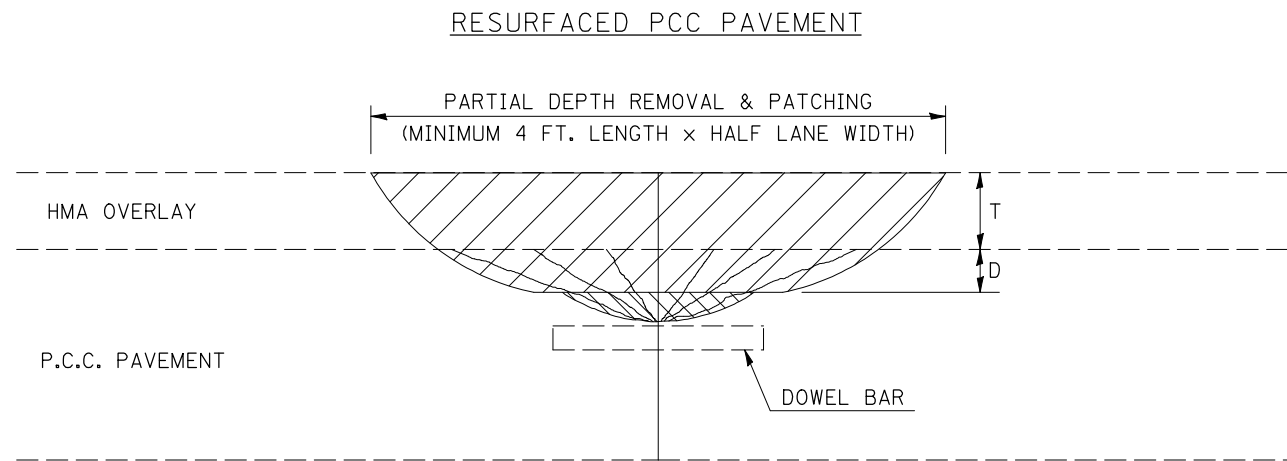

DESIGN NOTES

PARTIAL DEPTH HMA PATCHING SHALL NOT BE USED WHEN HMA OVERLAY THICKNESS (T) ON PCC PAVEMENT EXCEEDS 4 3/4 INCHES (145 mm) OR ON CRC PAVEMENT.

GENERAL NOTES

ALL VOLUME OF PARTIAL DEPTH REMOVAL SHALL BE REPLACED WITH HOT-MIX ASPHALT (HMA) AND PAID FOR AT THE CONTRACT UNIT PRICE PER TON FOR PARTIAL DEPTH PATCHING.

T = THICKNESS OF HMA OVERLAY(S). SEE EXISTING TYPICAL CROSS SECTION.

GENERAL NOTE 406H SHALL INCLUDE MIXTURE REQUIREMENTS FOR PARTIAL DEPTH PATCHING.

HMA REPLACEMENT IN RESURFACED PCC PAVEMENT LOCATIONS SHALL BE ACCORDING TO SECTION 406 OF THE STANDARD SPECIFICATIONS.

D = DEPTH OF PARTIAL DEPTH REMOVAL INTO EXISTING PCC PAVEMENT. (3" (75 mm) ± OR TO SOUND CONCRETE)

TRANSVERSE CONTRACTION JOINT SHOWN - OTHER LOCATIONS SIMILAR.

Note: All dimensions are in INCHES (millimeters) unless otherwise shown.

BARE PCC PAVEMENT

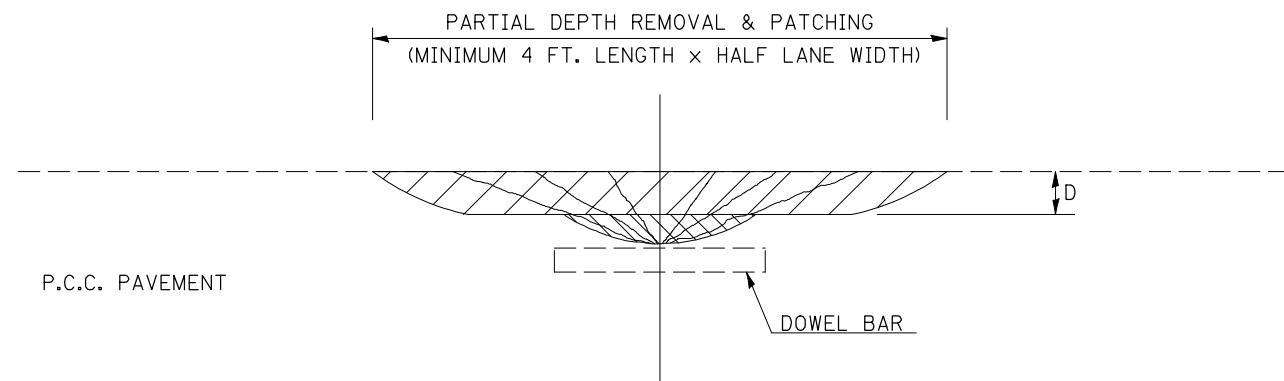

DISTRICT 5 DETAIL NO. XX442100

FILE NAME = #FILEL#	USER NAME = #USER#	DESIGNED -	REVISED - 11/06
		DRAWN -	REVISED -
	PLOT SCALE = #SCALE#	CHECKED -	REVISED -
	PLOT DATE = #DATE#	DATE -	REVISED -

**STATE OF ILLINOIS
DEPARTMENT OF TRANSPORTATION**

PCC PARTIAL DEPTH HOT-MIX ASPHALT PATCHING

SCALE: SHEET NO. OF SHEETS STA. TO STA.

F.A.P. RTE.	SECTION	COUNTY	TOTAL SHEETS	SHEET NO.
709	(113R)RS-1	CHAMPAIGN	65	63
FED. ROAD DIST. NO. ILLINOIS FED. AID PROJECT			CONTRACT NO. 70117	

XZ193300 – SURVEY MARKER, TYPE 1 (SPECIAL)

TO BE INSTALLED IN FLEXIBLE PAVEMENT OR SHOULDER, BITUMINOUS TREATED SURFACE AND TURF AREAS WITHIN THE RIGHT-OF-WAY FOR PRESERVING PERMANENT SURVEY MARKERS (PI'S, PT'S, PC'S, POC'S, & POT'S)

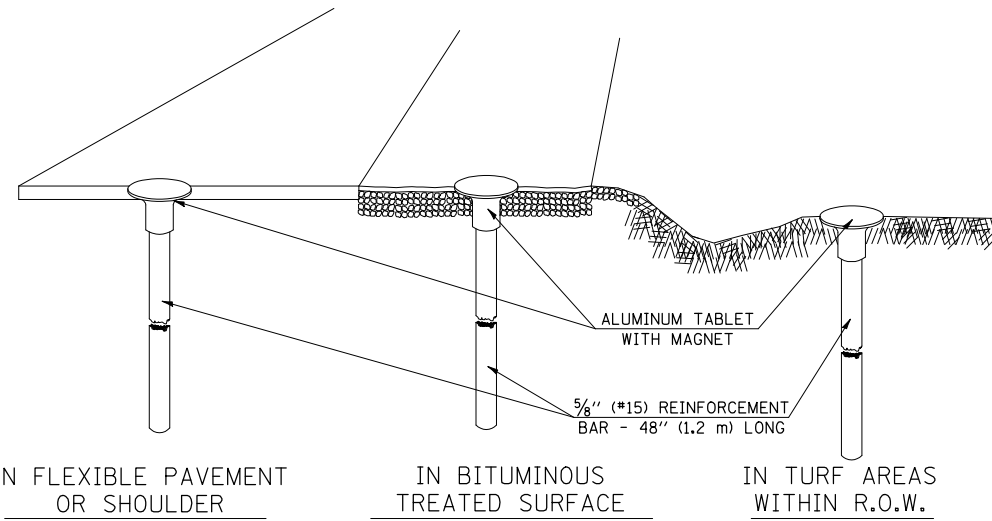

SPECIFICATIONS FOR ALUMINUM TABLET

SURVEY CAP FOR REBAR. 3/4" (83 mm) CONVEX SURVEY CAP FOR 5/8" (15 mm) REBAR WITH ILLINOIS DEPARTMENT OF TRANSPORTATION LOGO. THIS LOGO SHALL PROVIDE LETTERS RECESSED INTO THE SURFACE A MINIMUM OF 1/32" (0.8 mm) FOR EASY AND LONG-TERM LEGIBILITY. THE ALUMINUM CAP FOR REBAR SHALL BE PRODUCED BY THE PROCESS OF ORBITAL FORGING TO PRODUCE A HIGH-STRENGTH AND DURABLE MARKER CAP WHICH WILL NOT CHIP OR BREAK AND PROVIDE A SMOOTH FINISH FOR STAMPING OF DATA IN THE FIELD. THE ALUMINUM CAP FOR REBAR SHALL BE TAPERED FOR A PERFECT COMPRESSION FIT. A SPECIAL PLASTIC INSULATOR SHALL BE INSTALLED TO PREVENT DISSIMILAR METAL CONTACT AND CORROSION. THE PLASTIC INSULATOR SHALL FORM READILY TO THE OUTER SHAPE OF THE REBAR AND TO THE INNER SHAPE OF THE ALUMINUM CAP SOCKET. THE PLASTIC INSULATOR SHALL BE LOW DENSITY POLYETHYLENE, A MINIMUM 1 1/2" (38 mm) LONG AND CONFORM TO FEDERAL SPECIFICATION L-P 390.

COMPOSITION: ALUMINUM 98.3-98.7%; OTHER 1.3-1.7%; STRENGTH: YIELD 28 KSI (193 MPa), ULTIMATE 32 KSI (221 MPa). ELONGATION 15% [IN 2" (50 mm)]. SPECIFICATIONS: ALUMINUM ALLOY 6101-0; ASTM B317-83 (EXCEPT TEMPER) AS FORGED. NO EXCEPTIONS.

SPECIFICATIONS FOR REBAR

REBAR FOR ALUMINUM TABLET. REINFORCEMENT BAR SHALL BE 5/8" (#15) X 48" (1.2 m) (DEFORMED).

INSPECTION OF REINFORCEMENT BAR 5/8" (#15) SHALL BE DONE BY DISTRICT PERSONNEL OF THE ILLINOIS DEPARTMENT OF TRANSPORTATION, DIVISION OF HIGHWAYS.

XZ193400 – SURVEY MARKER, TYPE 2 (SPECIAL)

TO BE INSTALLED IN RIGID OR COMPOSITE PAVEMENT FOR PRESERVING PERMANENT SURVEY MARKERS (PI'S, PT'S, PC'S, POC'S, & POT'S)

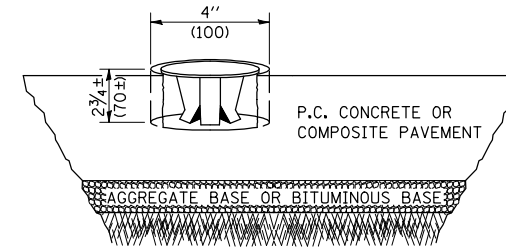

SPECIFICATIONS FOR ALUMINUM TABLET (FORKED)

ALUMINUM TABLET (FORKED) FOR USE WITH "SURVEY MARKER, TYPE 2, (SPECIAL)" SHALL BE AS SHOWN ON THE DETAIL FOR THE 3/4" (83 mm) CONVEX SURVEY TABLET WITH ILLINOIS DEPARTMENT OF TRANSPORTATION LOGO. THIS LOGO SHALL PROVIDE FOR LETTERS RECESSED INTO THE SURFACE A MINIMUM OF 1/32" (0.8 mm) FOR EASY AND LONG-TERM LEGIBILITY. THE ALUMINUM TABLET SHALL BE PRODUCED BY THE PROCESS OF ORBITAL FORGING TO PRODUCE A HIGH-STRENGTH AND DURABLE MARKER CAP WHICH WILL NOT CHIP OR BREAK AND PROVIDE A SMOOTH FINISH FOR STAMPING OF DATA IN THE FIELD. THE ALUMINUM TABLET SHALL BE DESIGNED NOT TO TURN OR ROTATE. THREE PRONGS ON A 2 1/2" (63 mm) STEM SHALL BE SUCH THAT THE ALUMINUM TABLET CANNOT BE EASILY REMOVED.

COMPOSITION: ALUMINUM 92-93%; MAGNESIUM 6.5-7.5%. STRENGTH: YIELD 19,000-21,000 PSI (131-145 MPa); TENSILE 38,000-44,000 PSI (262-303 MPa); ELONGATION 10-15% [IN 2" (50 mm)]. SPECIFICATIONS: ALLOY 535.0; QQ-A-601ES. NO EXCEPTIONS.

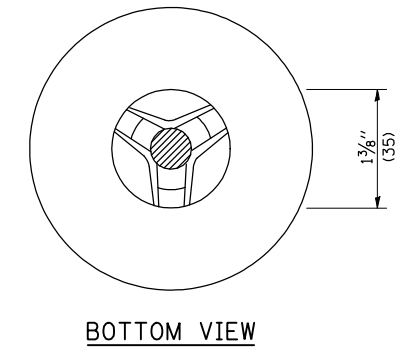
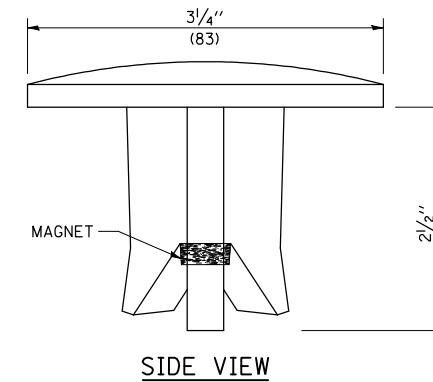

THE DIMENSIONS SHOWN SHALL BE EXACT, OTHERS MAY VARY, BUT SHALL BE SHOWN ON SHOP DRAWINGS.

GENERAL NOTES

1. WORK ON THIS ITEM SHALL NOT START UNTIL THE FINAL SURFACE IS COMPLETED.
2. THE ALUMINUM TABLET (FORKED) SHALL REST UPON THE BOTTOM OF THE 4" (100 mm) CORE HOLE. IF THE HOLE IS TOO DEEP, EPOXY GROUT MUST BE USED TO DECREASE THE DEPTH AND ALLOWED TO HARDEN BEFORE PROCEEDING.
3. THE ALUMINUM TABLET SHALL BE ANCHORED IN THE 4" (100 mm) DIAMETER HOLE IN THE NEW PAVEMENT WITH TWO-COMPONENT EPOXY CONFORMING TO APPLICABLE PORTIONS OF ARTICLE 1025.01 OF THE STANDARD SPECIFICATIONS.
4. THE 4" (100 mm) CORE HOLE SHALL BE SUBJECT TO THE APPROVAL OF THE ENGINEER.
5. THE CONTRACT PRICE, EACH, FOR SURVEY MARKER, TYPE 2 (SPECIAL) SHALL BE PAYMENT IN FULL FOR FURNISHING THE ALUMINUM TABLET AND ALL LABOR AND MATERIAL TO SET THE MARKER IN PLACE, AS SPECIFIED, INCLUDING CORING THE NEW PAVEMENT.
6. ALL SURVEY MARKERS, TYPE 2 (SPECIAL) SHALL BE PLACED ± 1/4" (6 mm) BELOW THE FINAL SURFACE.

Note: All dimensions are in INCHES (millimeters) unless otherwise shown.

DISTRICT 5 DETAIL NO. XZ193AAA

FILE NAME =	USER NAME = #USER*	DESIGNED -	REVISED - 11/06	STATE OF ILLINOIS DEPARTMENT OF TRANSPORTATION	SURVEY MARKERS TYPE 1 & 2 (SPECIAL)			F.A.P. RTE.	SECTION	COUNTY	TOTAL SHEETS	SHEET NO.
#FILE#		DRAWN -	REVISED -					709	(113R)RS-1	CHAMPAIGN	65	64
	PLOT SCALE = #SCALE*	CHECKED -	REVISED -		CONTRACT NO. 70117							
	PLOT DATE = #DATE*	DATE -	REVISED -		SCALE:	SHEET NO.	OF SHEETS	STA.	TO STA.	FED. ROAD DIST. NO.	ILLINOIS FED. AID PROJECT	

TO BE INSTALLED IN ALL PAVEMENT TYPES FOR PRESERVING PERMANENT SURVEY MARKERS (PI'S, PT'S, PC'S, POC'S, & POT'S) AND LAND SURVEY MONUMENTS (SECTION OR SUBSECTION CORNERS)

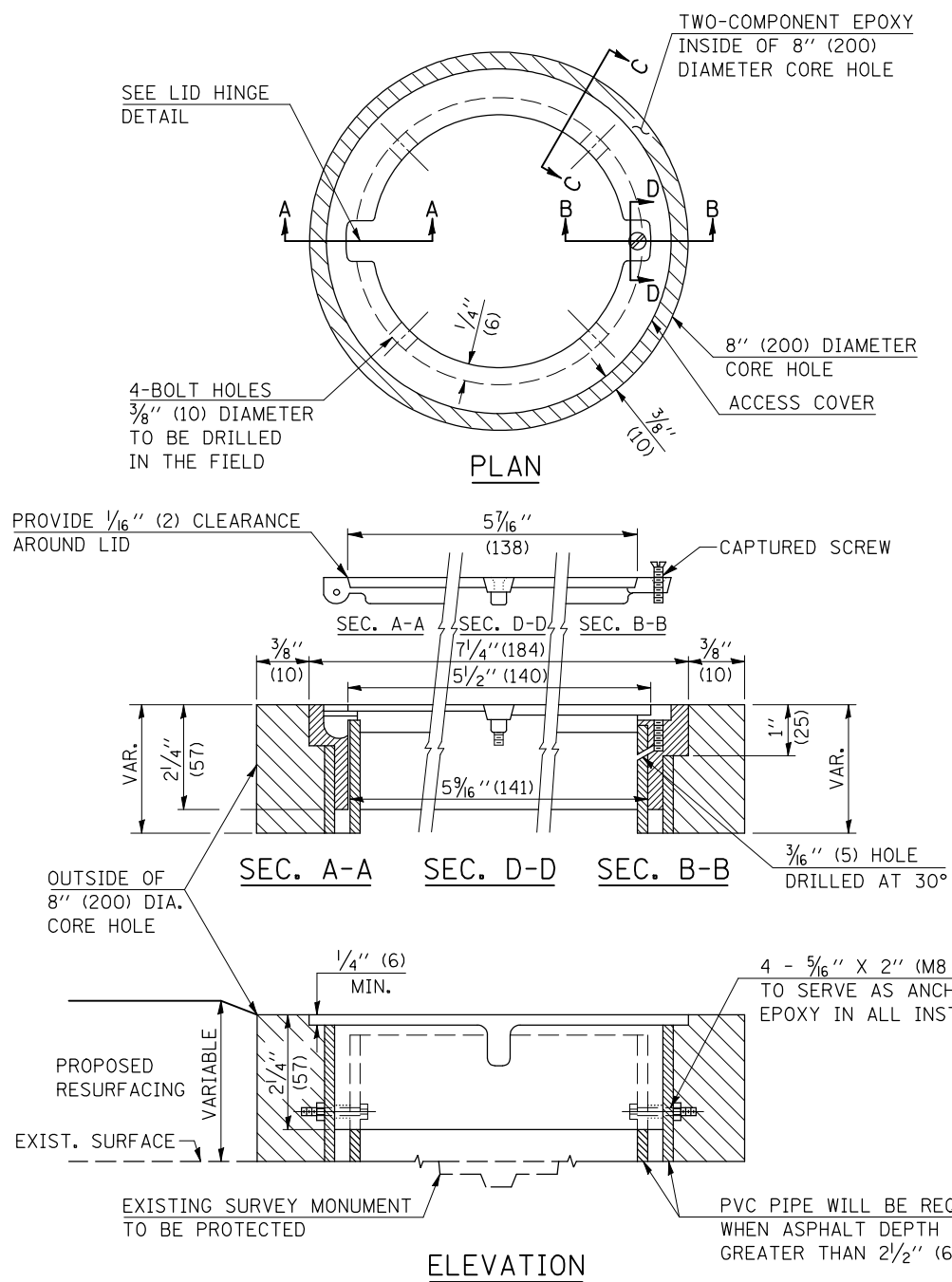

LEGEND

- ALUMINUM CASTING
- 5" (125) OR 6" (150) P.V.C. PIPE
- TWO-COMPONENT EPOXY

SPECIFICATIONS FOR ACCESS COVER FOR USE WITH SURVEY MARKER VAULT(S) AND SURVEY MARKER COVER ASSEMBLY(S): THE ACCESS COVER WILL BE CAST FROM A SPECIAL ALUMINUM ALLOY THAT IS COMPARABLE TO BRONZE IN HARDNESS. THE ACCESS COVER SHALL BE SPECIALLY ENGINEERED AND DESIGNED TO PROVIDE A SNUG FIT, INCORPORATING EQUIDISTANT LOCKING RIDGES, INSIDE A STANDARD 6" (150 mm) DIAMETER, OR OUTSIDE A STANDARD 5" (125 mm) DIAMETER, SCHEDULE 40 PVC PIPE. THE ACCESS COVER SHALL HAVE SPECIAL UNIFORM 1" (25 mm) THICK TOP SURFACE TO PERMIT INFORMATION TO BE EASILY MACHINE-STAMPED INTO IT. THE ACCESS COVER SHALL INCLUDE A STAINLESS CAPTURED SCREW AND AN OPPOSING RECESSED HINGE ASSEMBLY AS ITS LOCKING MECHANISM. THE ACCESS COVER SHALL INCORPORATE A SPECIAL ACCESS HOLE FOR CLEANING AND DRAINAGE, DRILLED AT 30° INSIDE THE RING OF THE ACCESS COVER, TO THE DRILLED AND TAPPED HOLE PROVIDED FOR THE STAINLESS CAPTURED SCREW. COMPOSITION: ALUMINUM 92-93%; MAGNESIUM 6.5-7.5%. STRENGTH: YIELD - 19,000-21,000 PSI (131-145 MPa); TENSILE - 38,000-44,000 PSI (262-303 MPa); ELONGATION - 10-15% IN 2" (50 mm). SPECIFICATIONS: ALLOY 535.0; Q0-A-601Es. NO EXCEPTIONS.

BILL OF MATERIAL

ALUMINUM CASTING OF THE DIMENSIONS AND SPECIFICATIONS SHOWN OR OTHER SUBJECT TO ENGINEER'S APPROVAL OF SHOP DRAWINGS, 4 EACH - 5/16" X 2" (M8 X 50) BOLTS WITH NUTS, EPOXY, 5" OR 6" (125 mm OR 150 mm) DIAMETER P.V.C. PIPE, SCHEDULE 40 (WHEN REQUIRED).

GENERAL NOTES

1. WORK SHALL NOT START ON THIS ITEM UNTIL THE FINAL LIFT OF SURFACE HAS BEEN COMPLETED.
2. THE SURVEY MONUMENT COVER ASSEMBLY SHALL BE CENTERED ABOVE THE SURVEY MONUMENT TO BE PROTECTED.
3. MODIFICATION OF THE ALUMINUM CASTING SHALL BE DONE BY GRINDING OR SAWING WHEN HEIGHT REDUCTION IS REQUIRED.
4. ALL SURVEY MONUMENT COVER ASSEMBLIES SHALL BE PLACED 1/4" (6 mm) ± BELOW THE FINAL SURFACE.
5. ALUMINUM CASTING SHALL BE PLACED OVER A 5" (125 mm) P.V.C. PIPE OR INSIDE OF A 6" (150 mm) P.V.C. PIPE WHEN AN INCREASE IN HEIGHT IS REQUIRED.
6. THE CASTING SHALL BE ANCHORED IN THE 8" (200 mm) DIAMETER CORE HOLE WITH TWO-COMPONENT EPOXY CONFORMING TO APPLICABLE PORTIONS OF ARTICLE 1025.01 OF THE STANDARD SPECIFICATIONS.
7. THIS WORK WILL BE PAID FOR AT THE CONTRACT UNIT PRICE EACH FOR SURVEY MONUMENT COVER ASSEMBLY WHICH PRICE SHALL INCLUDE ALL LABOR AND MATERIAL AS SPECIFIED INCLUDING CORING THE NEW PAVEMENT SURFACE AND EPOXY. NO ADDITIONAL COMPENSATION WILL BE ALLOWED.
8. THE 8" (200 mm) DIAMETER CORE HOLE SHALL BE SUBJECT TO THE APPROVAL OF THE ENGINEER.

Note: All dimensions are in INCHES (millimeters) unless otherwise shown.

DISTRICT 5 DETAIL NO. Z0070100

FILE NAME = #FILE#	USER NAME = #USER#	DESIGNED -	REVISED - 11/06	STATE OF ILLINOIS DEPARTMENT OF TRANSPORTATION	SURVEY MONUMENT COVER ASSEMBLY				F.A.P. RTE.	SECTION	COUNTY	TOTAL SHEETS	SHEET NO.
		DRAWN -	REVISED -		709	(113RRS-1)	CHAMPAIGN	65	65				
		CHECKED -	REVISED -		CONTRACT NO. 70117								
		DATE -	REVISED -		SCALE:	SHEET NO.	OF SHEETS	STA.	TO STA.	FED. ROAD DIST. NO.	ILLINOIS FED. AID PROJECT		