

NOTES:
 THE ACTUAL MEDIAN CONFIGURATION WILL BE AS SHOWN IN THE PLANS (TAPER OR REVERSE CURVE).
 RUMBLE & MOUNTABLE MEDIANS SHALL BE OUTLINED WITH [2].

TYPICAL MEDIAN TRANSITIONS

GENERAL NOTES

1. WHEN MEDIANS ARE PRESENT, PAVEMENT MARKINGS ARE TO BE PLACED ADJACENT TO MEDIANS.
2. SOME OF THE INFORMATION INCLUDED WITH THIS DETAIL MAY NOT BE APPLICABLE TO THIS IMPROVEMENT.
3. PAVEMENT MARKINGS ARE TO BE EXTENDED THROUGH OMISSIONS WHEN APPLICABLE.
4. A STRIPING KEY IS AVAILABLE ELSEWHERE AND SHALL BE SHOWN WHERE THE QUANTITIES ARE LISTED.
5. FINAL PAVEMENT MARKINGS SHALL BE IN PLACE PRIOR TO PLACING ANY RAISED REFLECTIVE PAVEMENT MARKERS.
6. THE FOLLOWING CRITERIA SHALL BE USED FOR SELECTING THE DIAGONAL PAVEMENT MARKING SPACING,
 < 30 MPH USE 15' (< 50 km/h USE 4.5 m)
 30-45 MPH USE 20' (50-75 km/h USE 6.0 m)
 > 45 MPH USE 30' (> 75 km/h USE 9.0 m)

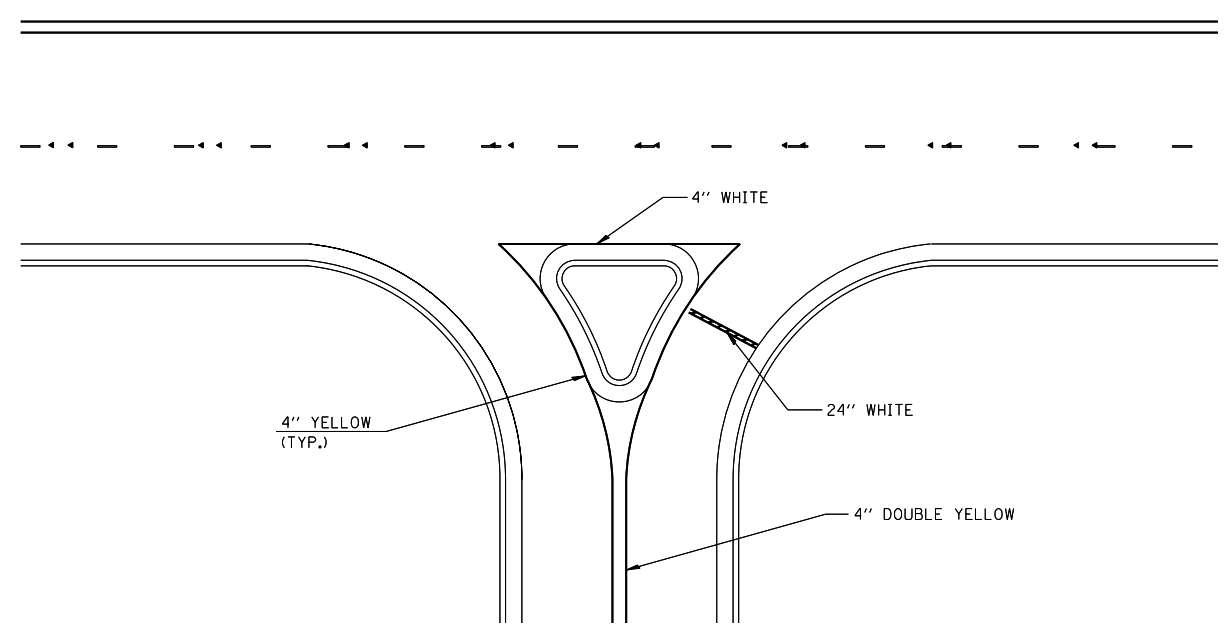

RIGHT IN - RIGHT OUT ACCESS

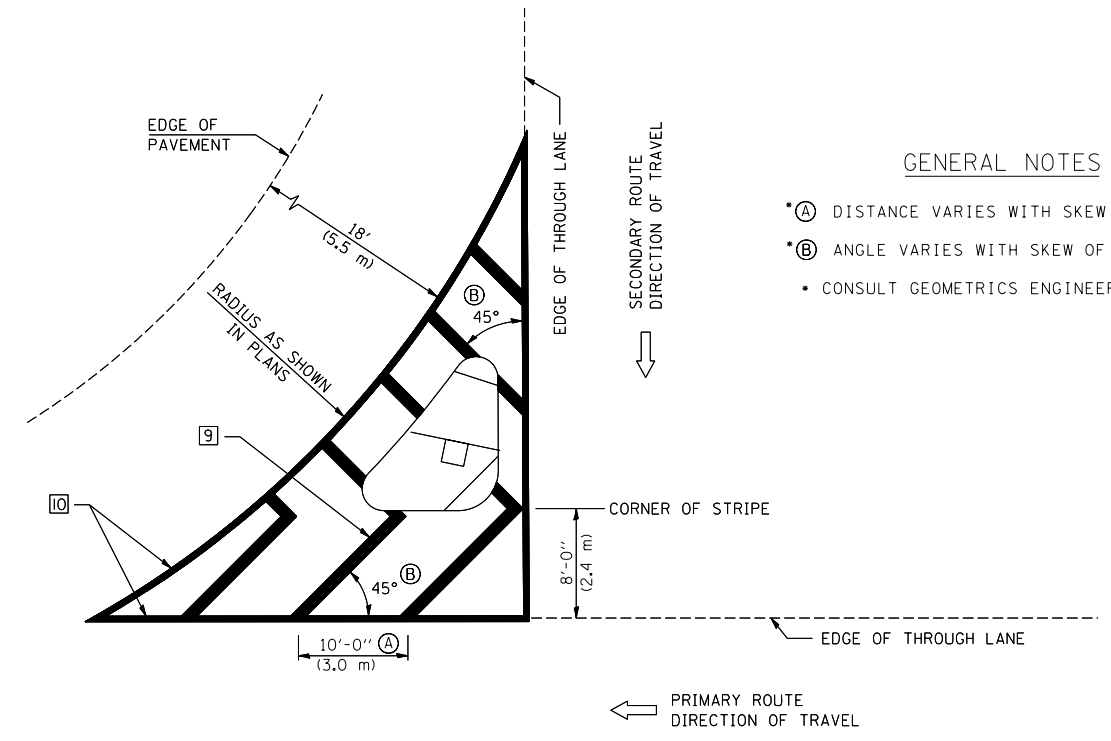

GENERAL NOTES

- (A) DISTANCE VARIES WITH SKEW OF INTERSECTION.
- (B) ANGLE VARIES WITH SKEW OF INTERSECTION.
- CONSULT GEOMETRICS ENGINEER

ISLAND

Note: All dimensions are in INCHES (millimeters) unless otherwise shown.

FILE NAME =	USER NAME = leroyma	DESIGNED -	REVISED - 11/06
ct:\pwwork\pwidot\LEROYMA\d0144976\d9505300.dgn		DRAWN -	REVISED - 09/2009 - KJT
	PLOT SCALE = 40.0000' / IN.	CHECKED -	REVISED -
	PLOT DATE = 1/29/2010	DATE -	REVISED -

**STATE OF ILLINOIS
 DEPARTMENT OF TRANSPORTATION**

**PAVEMENT MARKING AND MARKERS
 (RURAL & URBAN APPLICATIONS)**

SCALE: SHEET NO. 3 OF 4 SHEETS STA. TO STA.

DISTRICT 5 DETAIL NO. 7800AAA				
F.A.P. R.T.E.	SECTION	COUNTY	TOTAL SHEETS	SHEET NO.
332	(47)RS	VERMILION	25	23
CONTRACT NO. 70123				
FED. ROAD DIST. NO.	ILLINOIS	FED. AID PROJECT		