

BUTT JOINT AT BEGINNING OF PROJECT

STA 500+90

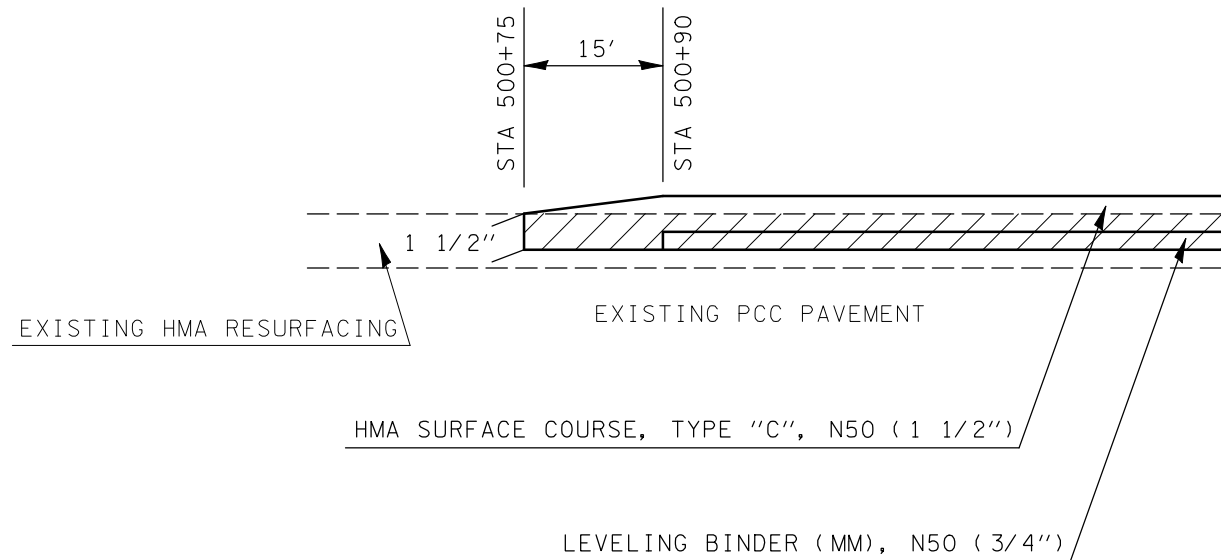

HMA SURFACE REMOVAL, 1 1/2"

BUTT JOINT AT END OF PROJECT

STA 896+30

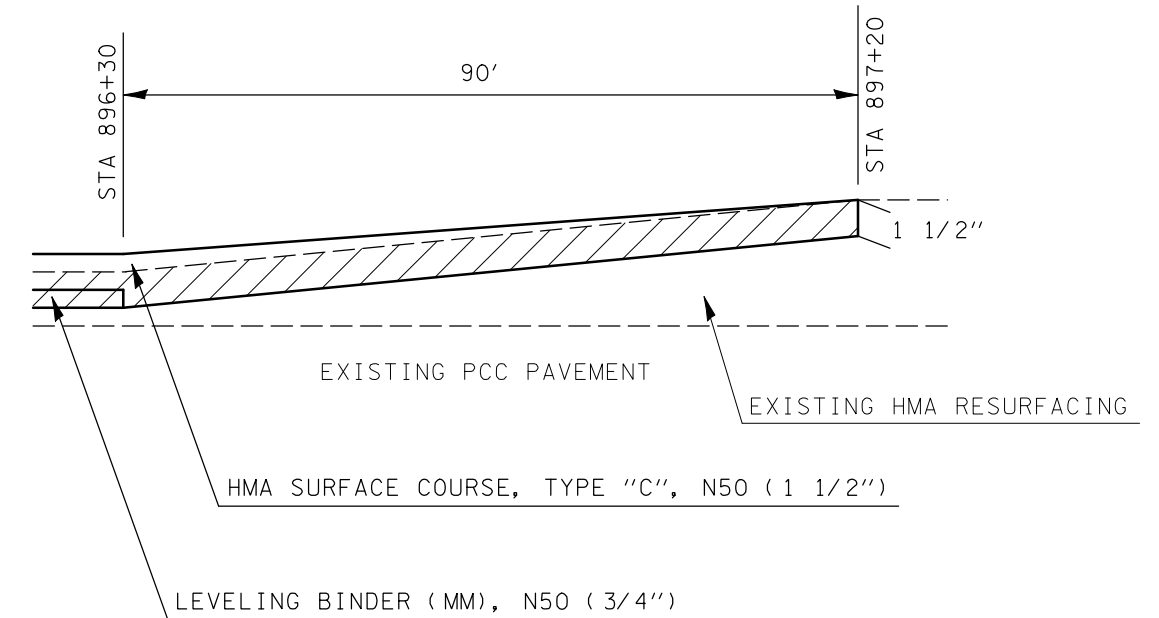

HMA SURFACE REMOVAL, 1 1/2"

BUTT JOINT AT STRUCTURES

SN 057-0220, 057-0221, 057-0222, 057-0110

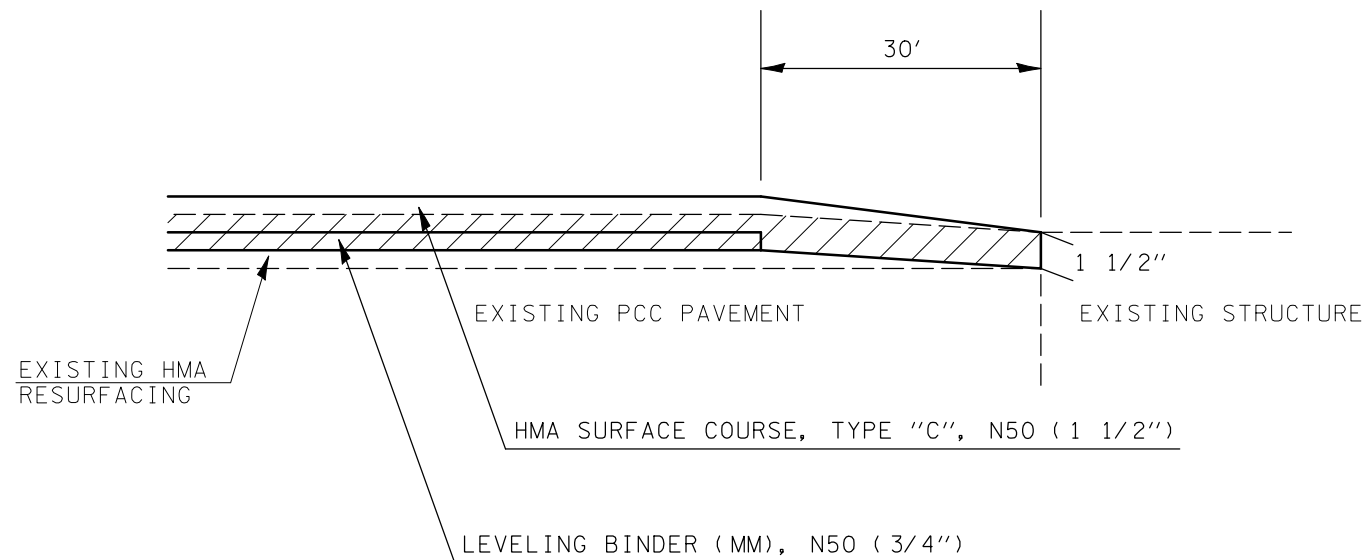

HMA SURFACE REMOVAL, 1 1/2"

FILE NAME =	USER NAME = coombessf	DESIGNED -	REVISED -
ct:\pw\work\PIWIDOT\COOMBESSF\dms87296\070510-sht-details.dgn		DRAWN -	REVISED -
	PLOT SCALE = 40.0000' / IN.	CHECKED -	REVISED -
	PLOT DATE = 1/13/2010	DATE -	REVISED -

STATE OF ILLINOIS
DEPARTMENT OF TRANSPORTATION

BUTT JOINT DETAILS

SCALE: SHEET NO. OF SHEETS STA. TO STA.

F.A.S. RTE.	SECTION	COUNTY	TOTAL SHEETS	SHEET NO.
2484	(125,126,127)RS-2	MCLEAN	122	50
CONTRACT NO. 70510				
ILLINOIS FED. AID PROJECT				