

* REDUCE TO 40 FEET (12.2 METERS) ON CENTER ON CURVES WHERE ADVISORY SPEEDS ARE 10 MPH (15 km/h) LOWER THAN POSTED SPEEDS.

** DOUBLE LANE LINE MARKERS SHALL BE SPECIFIED AND SPACED AS SHOWN IN HIGHWAY STANDARD 781001 FOR MULTI-LANE DIVIDED AND UNDIVIDED HIGHWAYS.

- GENERAL NOTES:**
- ⓑ TURN ARROW PAIRS SHALL BE PLACED AT 250' (75 m) INTERVALS AND SHALL BE EVENLY SPACED BETWEEN BOTH ENDS OF THE BIDIRECTIONAL LEFT TURN LANE.
 - ⓒ THE SOLID YELLOW PAVEMENT MARKINGS [2] SHOULD GENERALLY START OR END NEAR THE RADIUS POINT OF EACH STREET RETURN EXCEPT WHERE ONE OR BOTH ENDS WOULD INCLUDE STOP BARS.
 - ⓓ THE SKIP-DASH PAVEMENT MARKINGS [1] OR [7] SHOULD BE CENTERED BETWEEN BOTH ENDS OF EACH CITY BLOCK AND SHALL BE PLACED SO THEY LINE UP ACROSS FROM EACH OTHER. SEE EXAMPLE ON SHEET 2 OF 3.
 - ⓔ USE LARGE ARROW SIZE FOR BOTH RURAL AND URBAN LOCATIONS. (SEE LAST PAGE OF SECTION 780x FOR SYMBOLS TABLE)

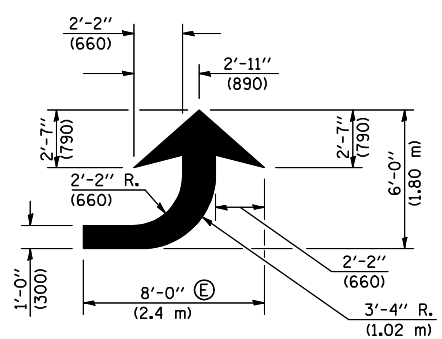

LEFT ARROW
 REVERSE FOR RIGHT ARROW
 AREA = 15.6 SQ. FT. (1.47 m²)
 (WHITE)

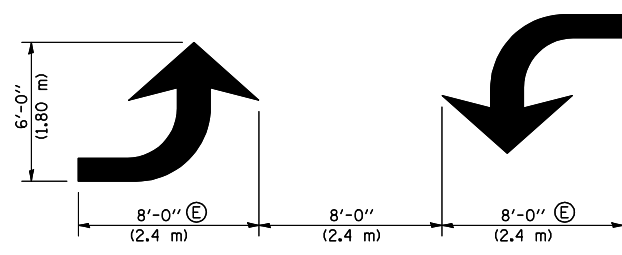

TYPICAL DOUBLE TURN ARROWS (WHITE)

BLOOMINGTON-NORMAL CITY LIMITS ONLY

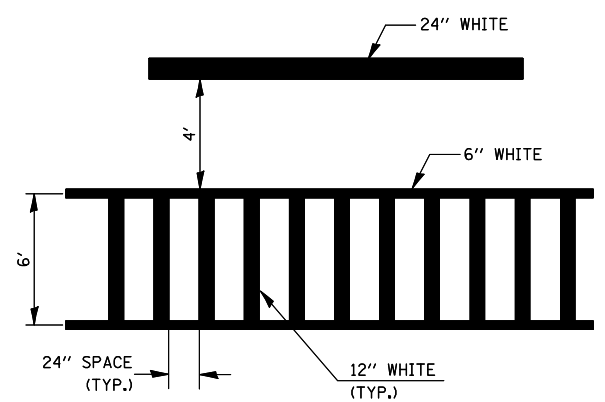

TYPICAL SPACING FOR CROSSWALKS & STOP BARS

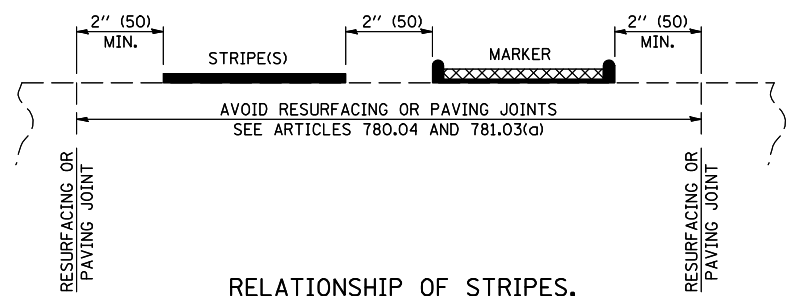

RELATIONSHIP OF STRIPES, MARKERS AND JOINTS

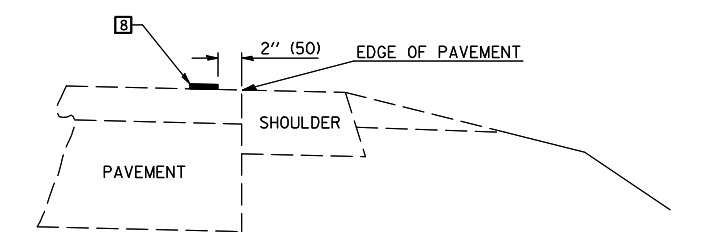

RELATIONSHIP OF EDGE LINE TO EDGE OF PAVEMENT
 (SAFETY SHOULDER OR PAVED SURFACE)
 SEE ARTICLE 780.04

Note: All dimensions are in INCHES (millimeters) unless otherwise shown.

DISTRICT 5 DETAIL NO. 7800AAA

FILE NAME =	USER NAME = bowerml	DESIGNED -	REVISED -	STATE OF ILLINOIS DEPARTMENT OF TRANSPORTATION	PAVEMENT MARKING AND MARKERS (RURAL & URBAN APPLICATIONS)				F.A.U. RTE.	SECTION	COUNTY	TOTAL SHEETS	SHEET NO.
ct:\pw\work\p\WIDOT\BOWERML\d0115116\d570539-sh1-details.dgn		DRAWN -	REVISED -						6406	IRS-3	MCLEAN	33	31
PLOT SCALE = 40.0000' / IN.		CHECKED -	REVISED -						CONTRACT NO. 70539				
PLOT DATE = 1/29/2010		DATE -	REVISED -						ILLINOIS FED. AID PROJECT				
					SCALE:	SHEET NO.	OF SHEETS	STA.	TO STA.				