

### DETAILS OF MAILBOX TURNOUTS

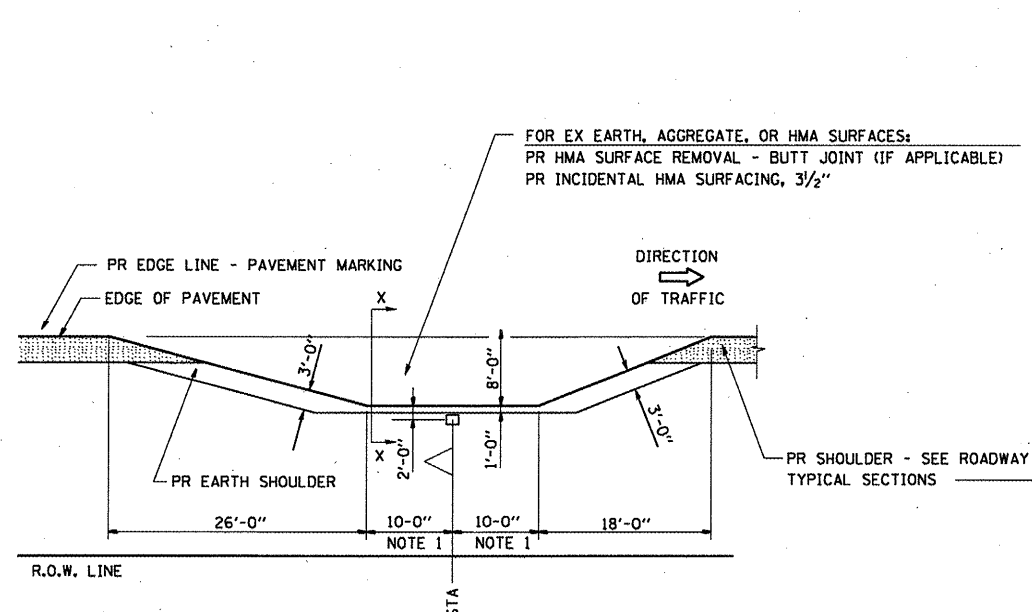

PLAN - MAILBOX TURNOUTS

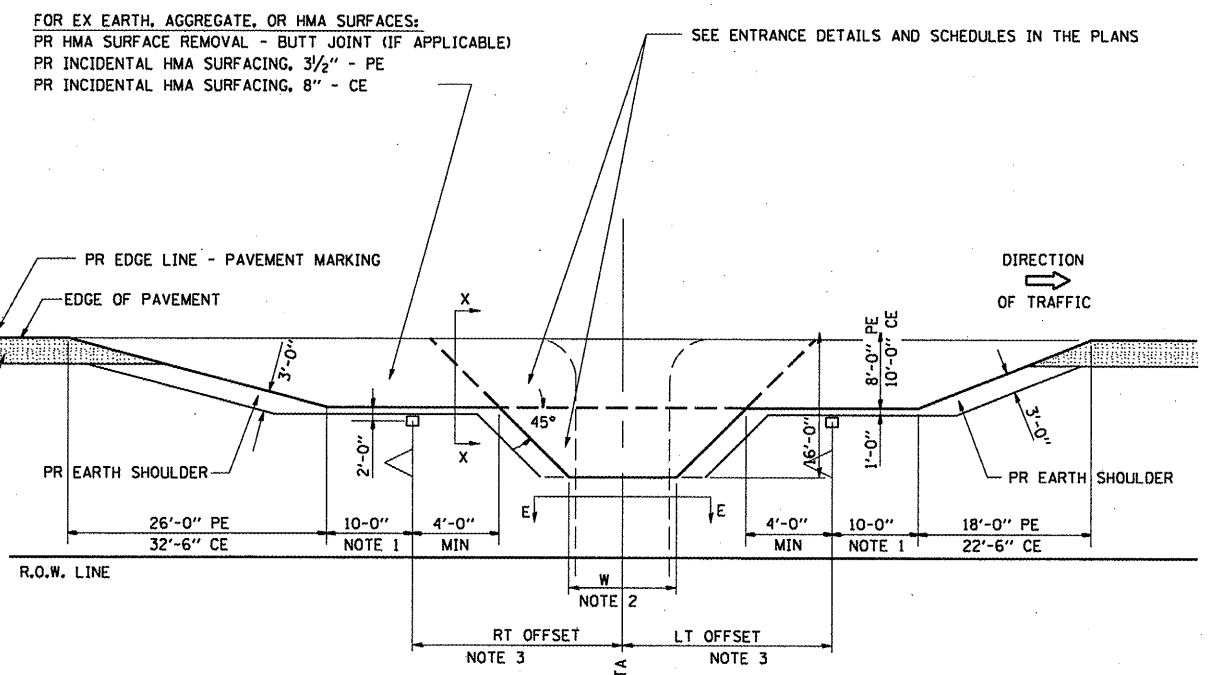

PLAN - COMBINED MAILBOX TURNOUT WITH TRAILING OR LEADING ENTRANCE

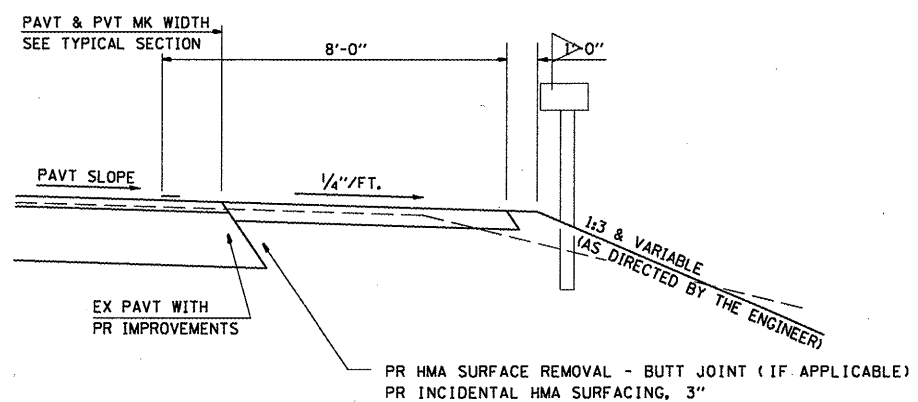

SECTION X-X THRU MAILBOX TURNOUT  
ALSO APPLIES TO MAILBOX TURNOUTS COMBINED WITH  
EX EARTH, AGGREGATE, OR BITUMINOUS PE & FE

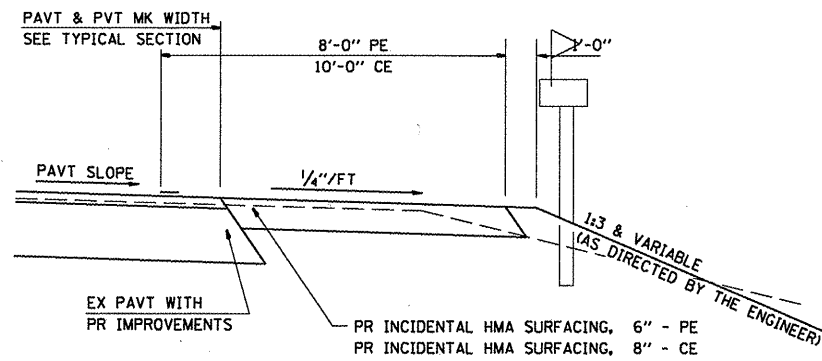

SECTION X-X THRU MAILBOX TURNOUT  
COMBINED WITH EX BITUMINOUS CONC & PC CONC PE & CE

ALL DIMENSIONS ARE IN INCHES  
UNLESS OTHERWISE SHOWN.

- NOTE 1 IF MORE THAN ONE MAILBOX IS PRESENT, DIMENSION FROM CENTER OF END MAILBOX.

NOTE 2 FOR ENTRANCE LAYOUT DIMENSIONS AND SECTIONS A-A & E-E REFER TO THE SCHEDULES IN THE PLANS.

NOTE 3 BOTH LT OR RT OFFSETS FOR MAILBOX SHOWN USE OFFSET DIMENSION PER SCHEDULE AND REFER TO LAYOUT SHOWN ON THE PLAN.

FILE NAME =	USER NAME = coxjm	DESIGNED - CAD	REVISED -	<b>STATE OF ILLINOIS DEPARTMENT OF TRANSPORTATION</b>	<b>DETAILS FOR RURAL ENTRANCE, MAILBOX TURNOUT &amp; SIDE ROAD</b>	F.A.P. RTE.	SECTION	COUNTY	TOTAL SHEETS	SHEET NO.	
cd:\pw_work\VPWIDOT\COXJM\dms23631\shdtdp11.dgn	DRAWN - CAD	REVISD -				566	(1-NRHM,2)RS-3	Scott	30	29	
PLOT SCALE = 186.8888' / IN.	CHECKED - RSC	REVISD -				CONTRACT NO. 72882					
PLOT DATE = Aug-19-2009 07:57:14AM	DATE -	REVISD -				FED. ROAD DIST. NO. ILLINOIS FED. AID PROJECT					
					SCALE:	SHEET NO. 2 OF 3 SHEETS		STA. 202+84.33 TO STA. 448+98.00			