

BUTT JOINT DETAILS

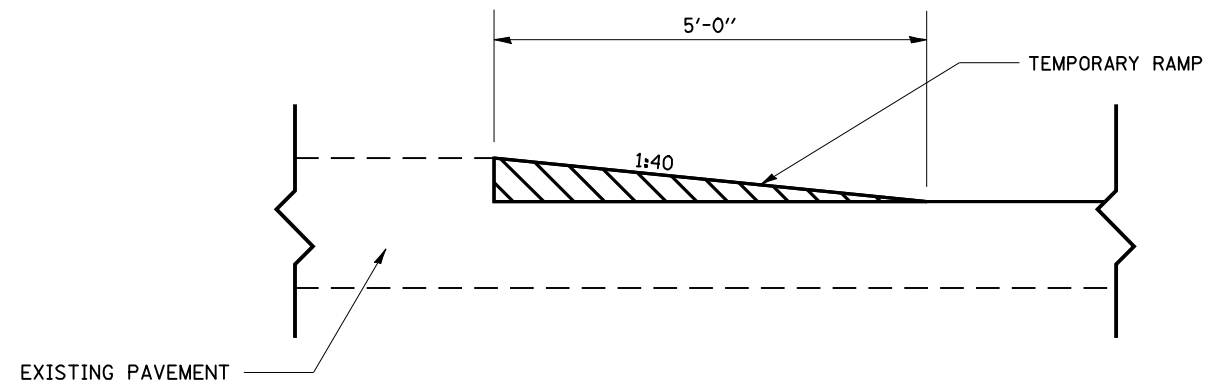

TEMPORARY RAMP DETAILS

FILE NAME =	USER NAME = laughlinr1	DESIGNED -	REVISED -	STATE OF ILLINOIS DEPARTMENT OF TRANSPORTATION	BUTT JOINT AND TEMPORARY RAMP DETAILS			F.A.P. RTE.	SECTION	COUNTY	TOTAL SHEETS	SHEET NO.
e:\pwork\pwork\LAUGHLINRL\dms27159\672c28-sht-details.dgn		DRAWN -	REVISED -		514	107RS-5	HANCOCK	30	23			
PLOT SCALE = 40.0000' / IN.		CHECKED -	REVISED -		CONTRACT NO. 72C28							
PLOT DATE = Feb-08-2010 11:14:45AM		DATE -	REVISED -		SCALE:	SHEET NO. 1 OF 1 SHEETS	STA.	TO STA.	FED. ROAD DIST. NO. 6 ILLINOIS FED. AID PROJECT			