

STATE OF ILLINOIS
DEPARTMENT OF TRANSPORTATION

BEAM REACTIONS

RP	(K)	26.6
Rt	(K)	32.2
Imp.	(K)	8.5
R (Total)	(K)	67.3

TABLE A

Beam	t
1	1 1/4"
2	3/4"
3	1/4"
4	0
5	0
6	0

Notes:

Diaphragm removal and reinstallation may be required to facilitate drilling holes. Cost included with Furnishing and Erecting Structural Steel.

New steel extensions, shim plates and connection bolts are included with Furnishing and Erecting Structural Steel. Prior to ordering any material, the Contractor shall verify in the field all bearing height and shim thickness dimensions. Min. jack capacity = 36Tons.

Anchor bolts shall be ASTM F1554 all-thread (or an Engineer-approved alternate material) of the grade(s) and diameter(s) specified. ASTM A307 Grade C anchor bolts may be used in lieu of ASTM F1554 Grade 36 (Fy=36ksi). The corresponding specified grade of AASHTO M314 anchor bolts may be used in lieu of ASTM F1554.

Anchor bolts for Type II bearings shall be placed in holes drilled through the bottom bearing plate after members are in place. Side retainers shall be placed after bolts are installed.

Drilled and set anchor bolts shall be installed according to Article 521.06 of the Standard Specifications. Side retainers shall be included in the cost of Elastomeric Bearing Assembly, Type II.

The 1/8" PTFE sheet shall be bonded directly to the top steel plate with a two-component, medium viscosity epoxy resin, conforming to the requirements of the Federal Specification MMM-A-134, Type I. The bond agent shall be applied on the full area of the contact surfaces.

Bonding of 1/8" PTFE sheet during vulcanizing process will be permitted provided the process and method of adjusting assembly height is approved by the Engineer.

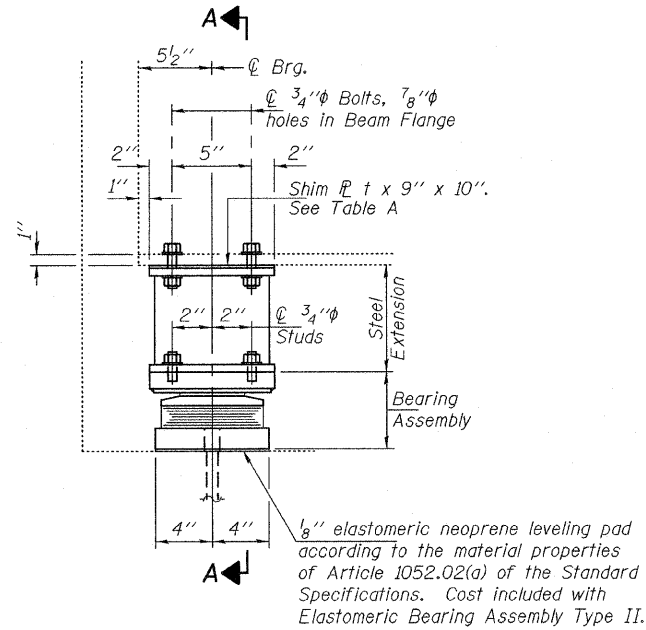

ELEVATION AT S. ABUTMENT

TYPE II TFE ELASTOMERIC EXP. BRG.

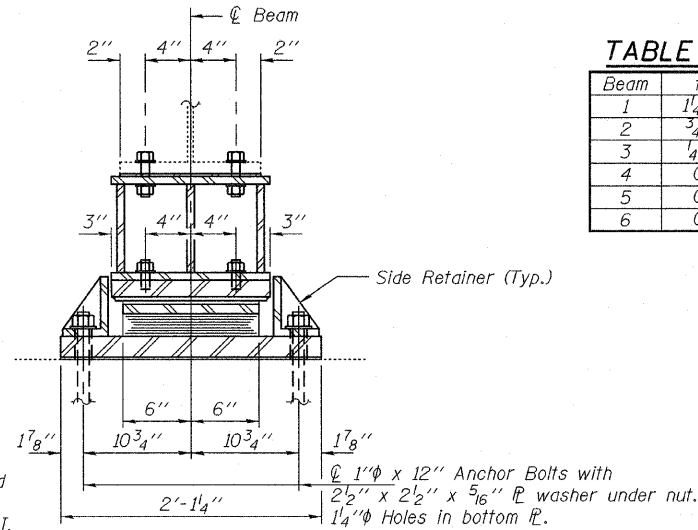

SECTION A-A

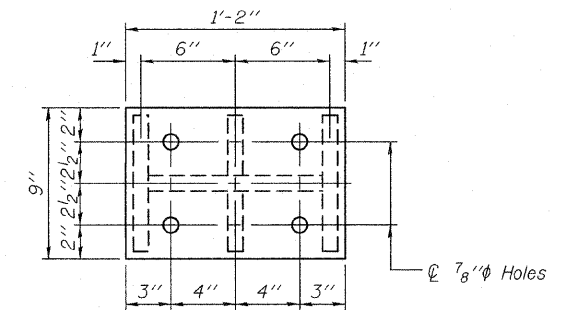

PLAN TOP AND BOTTOM PLATE

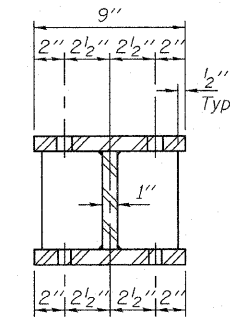

SECTION B-B

STEEL EXTENSION DETAIL

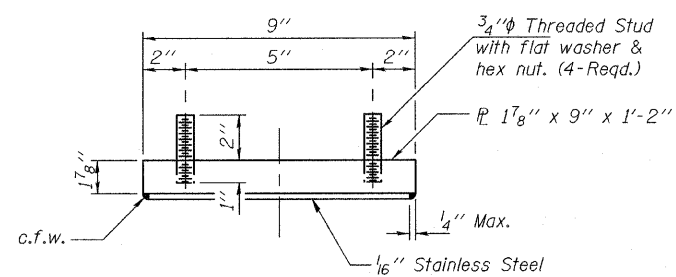

TOP BEARING ASSEMBLY

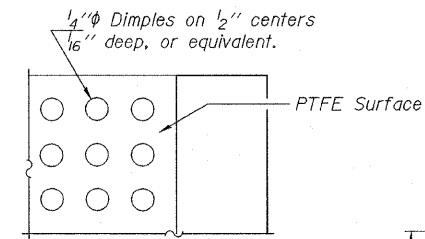

PLAN-PTFE SURFACE

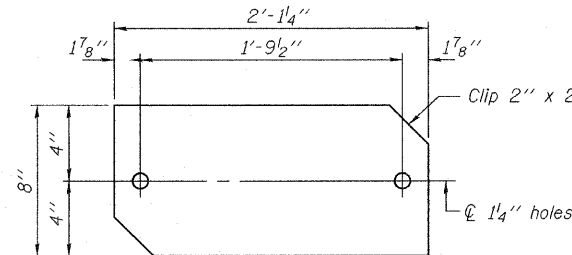

PLAN BOTTOM BEARING PLATE

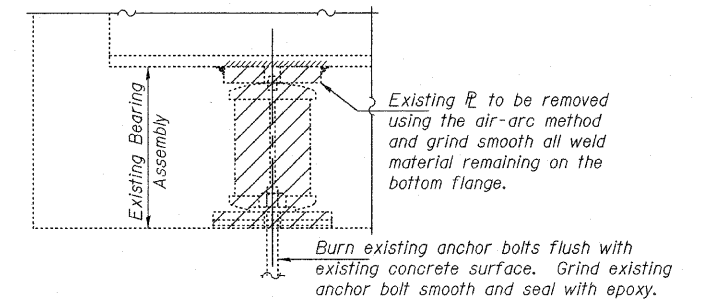

EXISTING BEARING REMOVAL DETAIL

Cost included with Jack and Remove Existing Bearings.

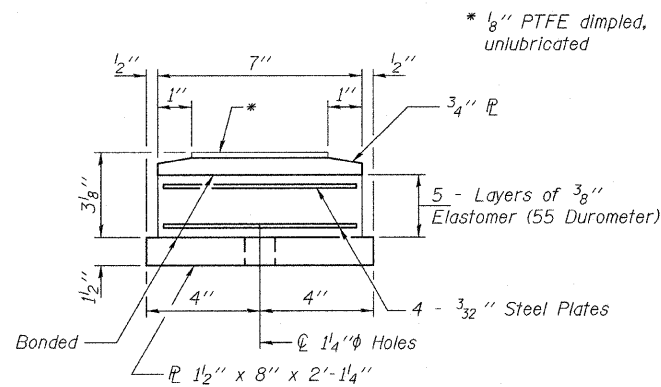

BOTTOM BEARING ASSEMBLY

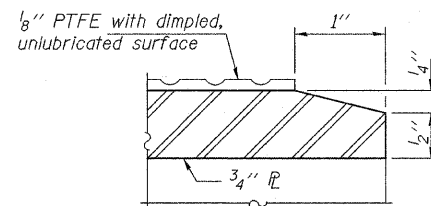

SECTION THRU PTFE

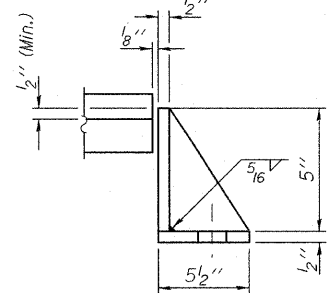

SIDE RETAINER

Equivalent rolled angle with stiffeners will be allowed in lieu of welded plates.

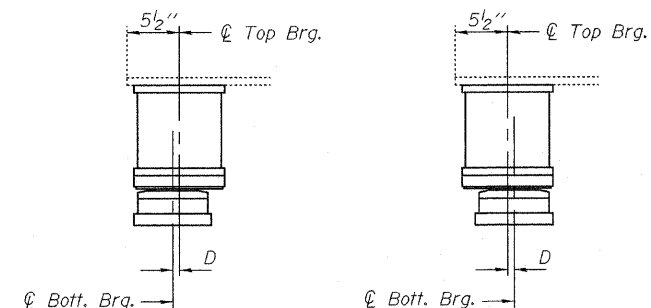

SETTING ANCHOR BOLTS AT EXP. BRG.

D = 1/8" per each 100' of expansion for every 15° temp. change from the normal temp. of 50°F.

BILL OF MATERIAL

Item	Unit	Total
Elastomeric Bearing Assembly, Type II	Each	6
Jack and Remove Existing Bearings	Each	6
Furnishing and Erecting Structural Steel	Pound	820
Anchor Bolts 1" ∅	Each	12

SOUTH ABUTMENT
BEARING REPLACEMENT DETAILS

IL 33 OVER CSXT RAILROAD
SN 051-0032

DESIGNED	IJL
CHECKED	GGE
DRAWN	baliva
CHECKED	IJL GGE

EXAMINED	MARCH 3, 2010 <i>A. Carl Powers</i> ENGINEER OF STRUCTURAL SERVICES
PASSED	<i>Ralph E. Anderson</i> ENGINEER OF BRIDGES AND STRUCTURES

TYII/REPS 12-03-2008

SHEET NO. 5 7 SHEETS	F.A.P. RTE. 783	SECTION (51-24-2.1-2)RS- 1&(1-X-1)RS-3	COUNTY LAWRENCE	TOTAL SHEETS 42	SHEET NO. 39
	CONTRACT NO. 74414			FED. ROAD DIST. NO. ILLINOIS FED. AID PROJECT	