

PROPOSED TYPICAL SECTION
STA. 329+70 TO STA. 334+70.5

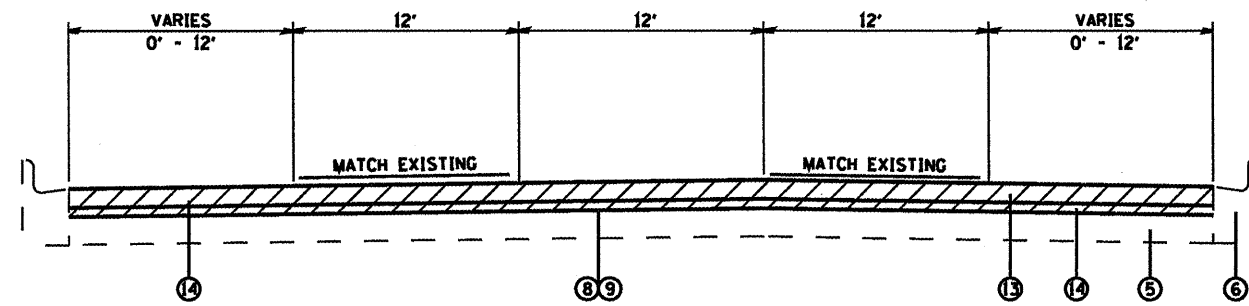

PROPOSED TYPICAL SECTION
STA. 353+55 TO STA. 402+35

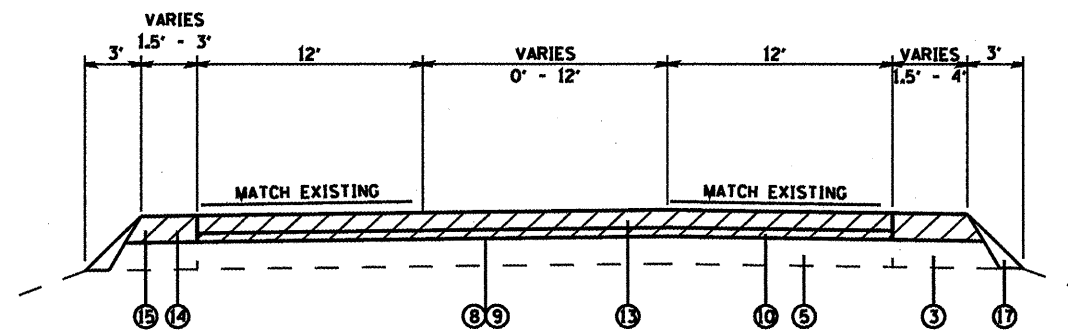

PROPOSED TYPICAL SECTION
STA. 402+35 TO STA. 456+57
• PROPOSED HMA SURFACE REMOVAL, 1 1/2"
FROM STA. 415+17.20 TO STA. 416+24.60

LEGEND

- ① EXISTING 13" AGGREGATE PAVEMENT
- ② EXISTING HOT-MIX ASPHALT PAVEMENT
- ③ EXISTING HOT-MIX ASPHALT SHOULDER
- ④ EXISTING AGGREGATE WEDGE
- ⑤ EXISTING PCC PAVEMENT
- ⑥ EXISTING PCC CURB AND GUTTER
- ⑦ EXISTING PCC MEDIAN
- ⑧ PROPOSED BITUMINOUS MATERIALS (PRIME COAT)
- ⑨ PROPOSED AGGREGATE (PRIME COAT)
- ⑩ PROPOSED LEVELING BINDER (MACHINE METHOD) 3/4"
- ⑪ PROPOSED LEVELING BINDER (MACHINE METHOD) 1"
- ⑫ PROPOSED HMA SURFACE COURSE 1 1/2"
- ⑬ PROPOSED POLYMERIZED HOT-MIX ASPHALT SURFACE COURSE 1 1/2"
- ⑭ PROPOSED HOT-MIX ASPHALT SURFACE REMOVAL 2 1/4"
- ⑮ PROPOSED HMA SHOULDERS
- ⑯ PROPOSED 1' HMA SHOULDER STRIP (SEE SHEET 42)
- ⑰ PROPOSED AGGREGATE WEDGE, TYPE B

FILE NAME *	USER NAME * allfordb	DESIGNED -	REVISED -	STATE OF ILLINOIS DEPARTMENT OF TRANSPORTATION	TYPICAL SECTIONS - OLD US 50	F.A.J. RTE.	SECTION	COUNTY	TOTAL SHEET NO.
en\pe\work\PMIDOT\VALFORDB\08174224\0876069\shl-plan.dgn	DRAWN - TRF	REVISED -	32RS-3, 3IRS-3, IRS-1			ST. CLAIR	56 12		
PLOT SCALE = 96.0000' / IN.	CHECKED -	REVISED -	CONTRACT NO. 76069						
PLOT DATE = 3/2/2010	DATE -	REVISED -	SCALE: NONE			SHEET NO. OF SHEETS	STA. TO STA.	FED. ROAD DIST. NO.	ILLINOIS FED. AID PROJECT