

* COST OF SAWCUT TO BE INCLUDED IN
 PCC SURFACE REMOVAL - BUTT JOINT

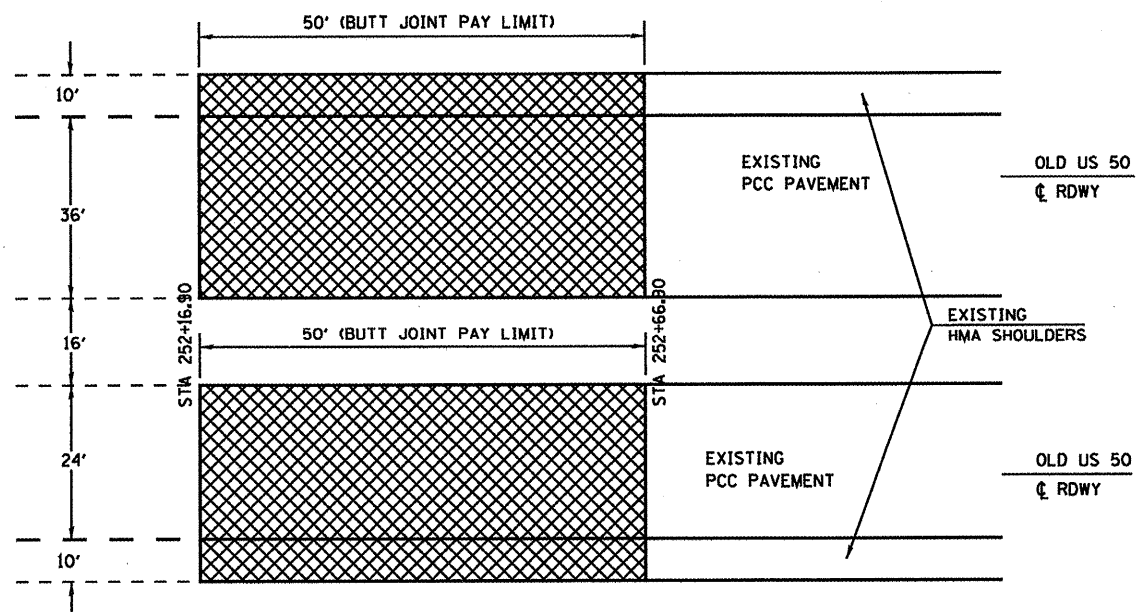

MARKER ORIENTATION
 WITHIN LIMITS SHOWN

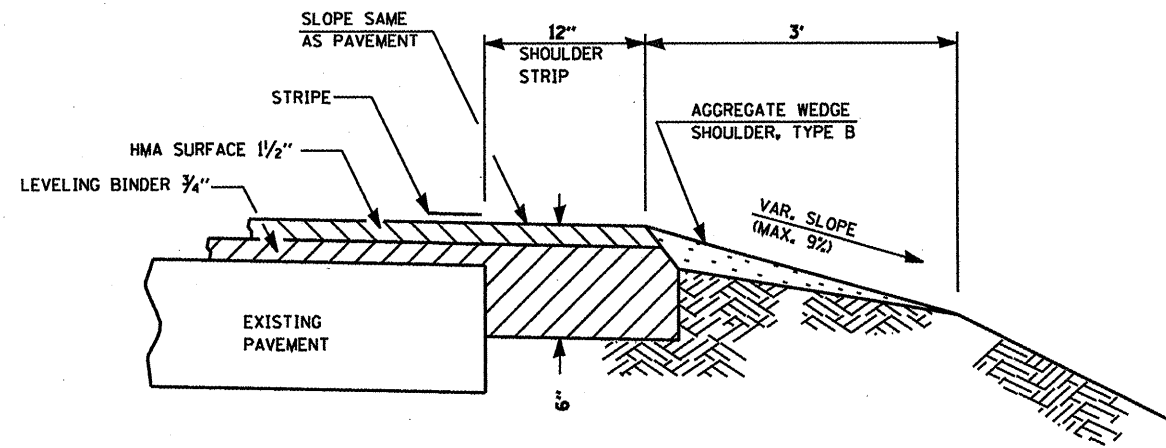
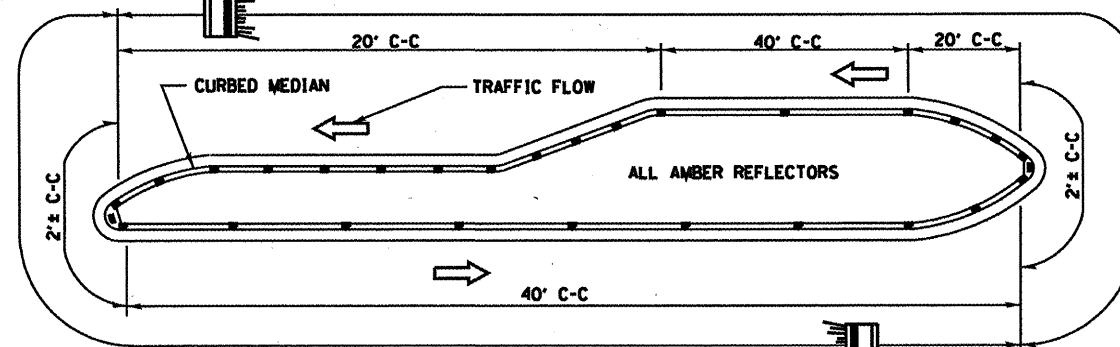

- NOTES**
1. PRISMATIC REFLECTORS SHALL BE MONO-DIRECTIONAL AND POSITIONED SO THAT THE REFLECTIVE FACE IS FACING THE APPROACHING TRAFFIC.
 2. PRISMATIC REFLECTORS SHALL BE SECURED IN PLACE WITH AN EPOXY ADHESIVE.
 3. PRISMATIC REFLECTORS SHALL BE EITHER AMBER OR CRYSTAL IN COLOR.

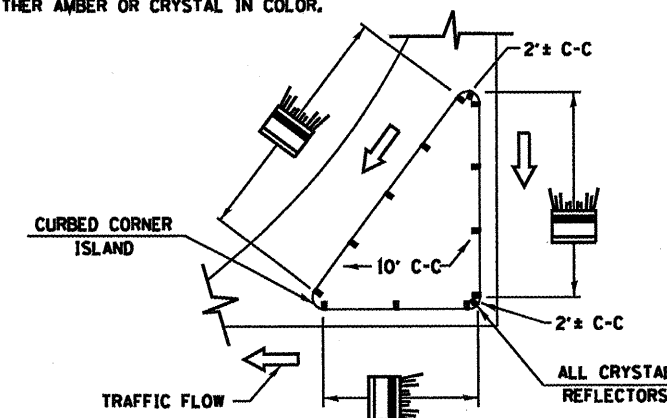
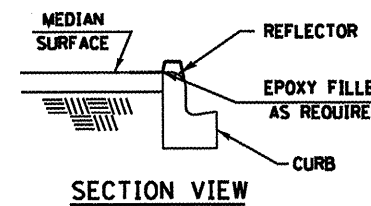

PCC SURFACE REMOVAL - BUTT JOINT

FILE NAME =	USER NAME = eifordb	DESIGNED -	REVISED -	STATE OF ILLINOIS DEPARTMENT OF TRANSPORTATION	JOINT DETAIL / MISC. DETAILS		F.A.U. RTE.	SECTION	COUNTY	TOTAL SHEETS	SHEET NO.
ca:\ps-work\psidot\elfordb\08174224\0876	99-shr-plan.dgn	DRAWN -	REVISED -				32RS-3, 3IRS-3, IRS-1	ST. CLAIR	56	42	
		CHECKED -	REVISED -				CONTRACT NO. 76069				
		DATE -	REVISED -				ILLINOIS FED. AID PROJECT				
	PLOT SCALE = 48,0000' / IN.			SCALE: NONE	SHEET NO.	OF	SHEETS	STA.	TO STA.		
	PLOT DATE = 3/2/2010										