

EXISTING TYPICAL SECTION W/REMOVAL

FAS 1780 (OLD US 50)

LOCATION 3

STA. 10+00 TO STA. 145+97

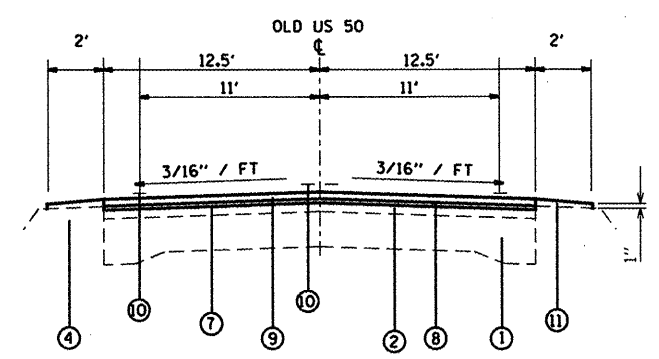

PROPOSED TYPICAL SECTION

FAS 1780 (OLD US 50)

LOCATION 3

STA. 10+00 TO STA. 145+97

- LEGEND**
- ① EXISTING PAVEMENT
 - ② EXISTING RESURFACING
 - ③ EXISTING HMA SHOULDER
 - ④ EXISTING TURF SHOULDER
 - ⑤ EXISTING PAVEMENT MARKINGS
 - ⑥ PROPOSED HMA SURFACE REMOVAL 1 1/2"
 - ⑦ PROPOSED PRIME COAT (BITUMINOUS & AGGREGATE)
 - ⑧ PROPOSED LEVELING BINDER (MACHINE METHOD) 3/4"
 - ⑨ PROPOSED HOT-MIX ASPHALT SURFACE COURSE, MIX D, N90 1 1/2"
 - ⑩ PROPOSED THERMOPLASTIC PAVEMENT MARKINGS
 - ⑪ PROPOSED AGG WEDGE SHOULDER TYPE B

FILE NAME =	USER NAME = #USER#	DESIGNED -	REVISED -
#FILEL#		DRAWN -	REVISED -
	PLDT SCALE = #SCALE#	CHECKED -	REVISED -
	PLDT DATE = #DATE#	DATE -	REVISED -

**STATE OF ILLINOIS
DEPARTMENT OF TRANSPORTATION**

LOCATION 3 TYPICAL SECTIONS			
SCALE:	SHEET NO.	OF SHEETS	STA. TO STA.

F.A.S. RTE.	SECTION	COUNTY	TOTAL SHEETS	SHEET NO.
1780	DIST 8 RESURFACING 2010-3	ST. CLAIR, CLINTON	33	7
CONTRACT NO. 76D77				
<small>FED. ROAD DIST. NO. [ILLINOIS] FED. AID PROJECT</small>				