

SIDEROAD AND ENTRANCE DETAILS

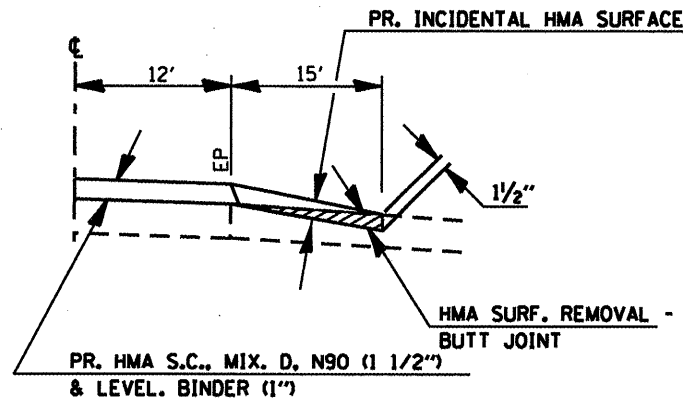

SIDE ROAD SEC. B-B
EX. BIT. OR CONC. SURFACE

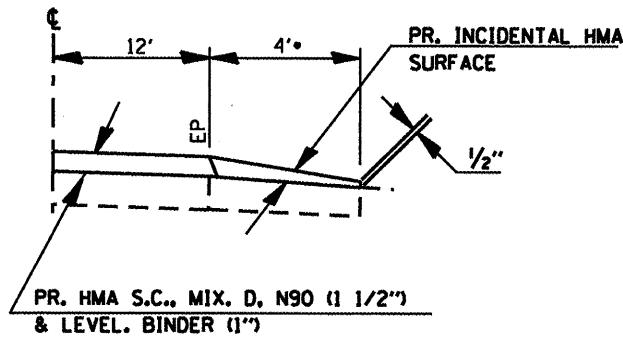

PE OR CE SEC. A-A
EX. BIT. OR CONC. SURFACE
•OR END OF BIT. APRON

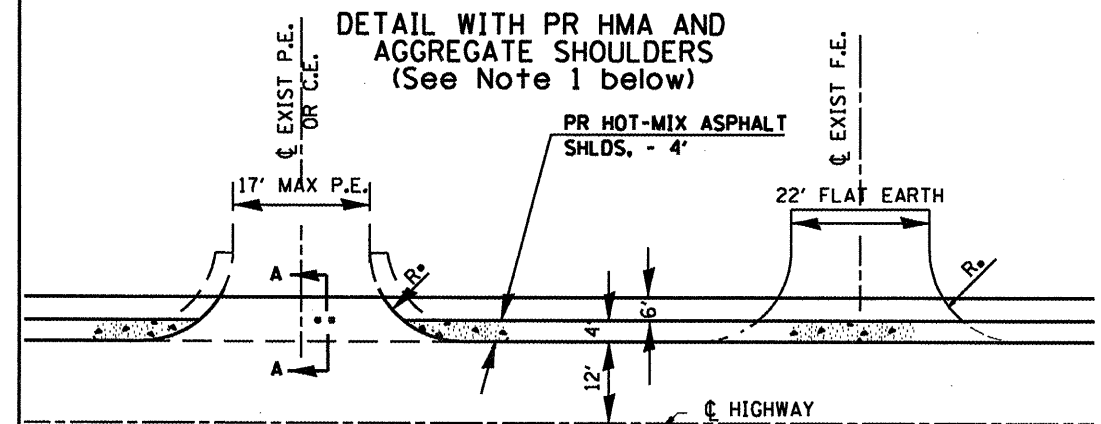

DETAIL WITH PR HMA AND AGGREGATE SHOULDERS
(See Note 1 below)

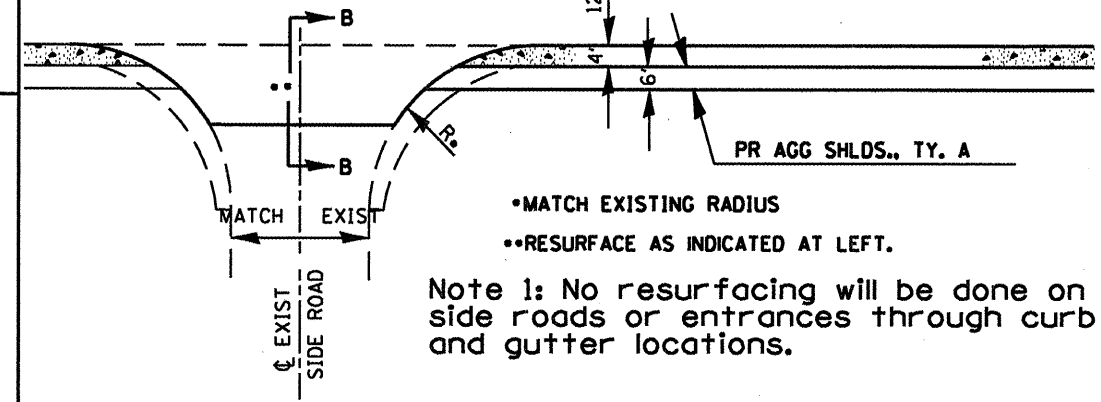

•MATCH EXISTING RADIUS
••RESURFACE AS INDICATED AT LEFT.
Note 1: No resurfacing will be done on side roads or entrances through curb and gutter locations.

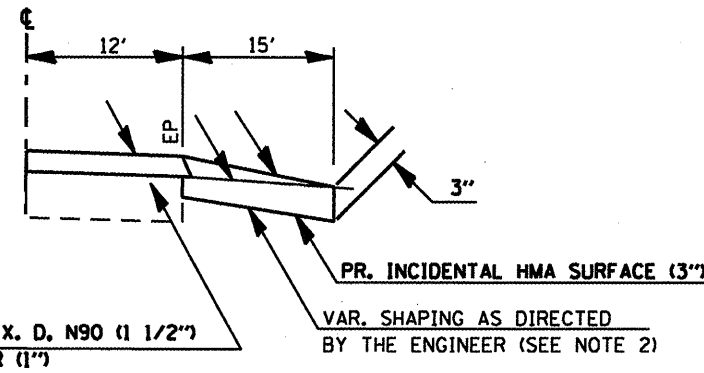

SIDE ROAD SEC. B-B
EX. AGGREGATE SURFACE
(SEE NOTE 1)

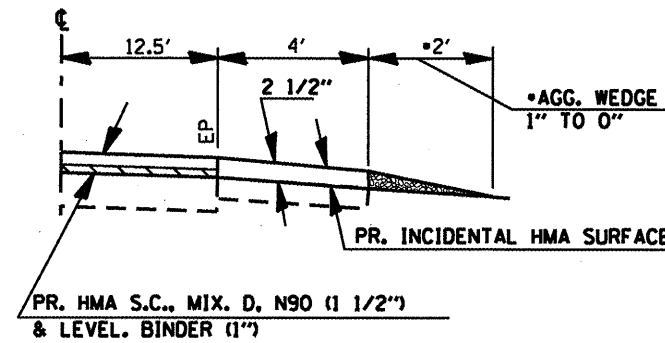

PE OR FE SEC. A-A
EX. AGGREGATE SURFACE WITH BIT. APRON
•SEE ENTRANCE SCHEDULE FOR QUANTITY.

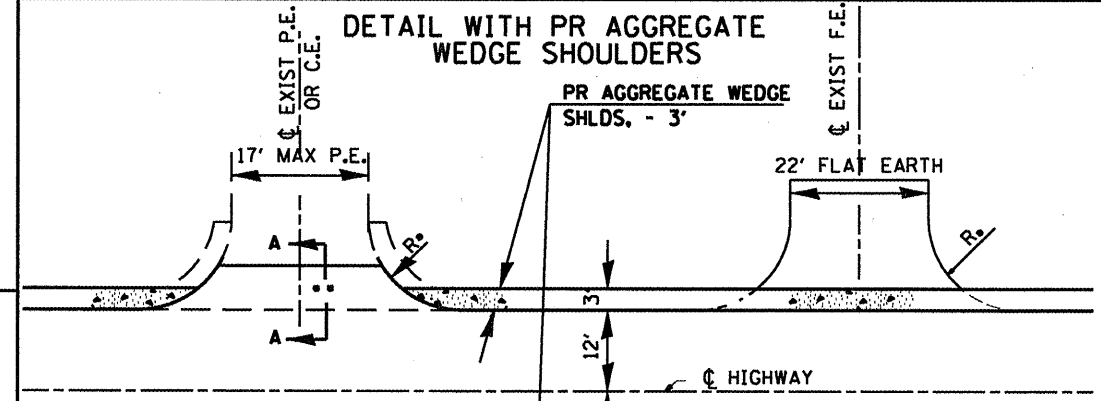

DETAIL WITH PR AGGREGATE WEDGE SHOULDERS

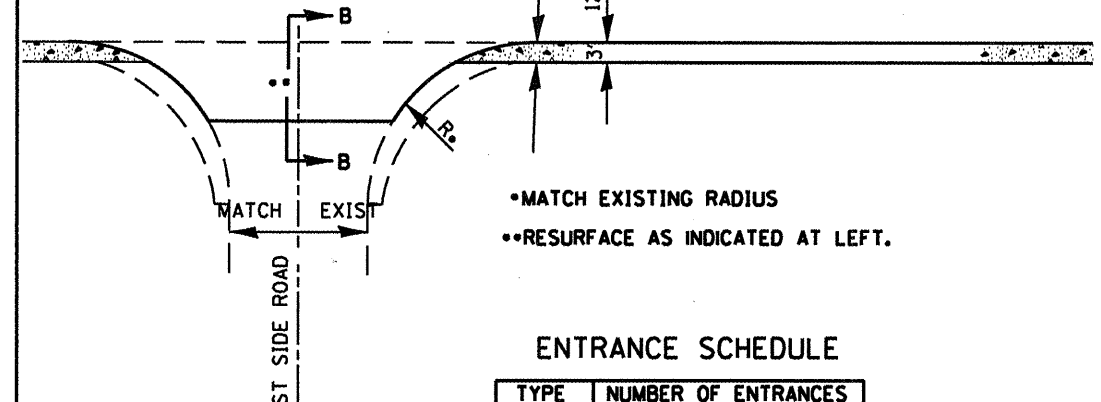

•MATCH EXISTING RADIUS
••RESURFACE AS INDICATED AT LEFT.

ENTRANCE SCHEDULE

TYPE	NUMBER OF ENTRANCES
P.E.	4
F.E.	2
S.R.	8

NOTES

- IF EXISTING SUBBASE IS INADEQUATE, AS DETERMINED BY THE ENGINEER, THE SIDE ROADS SHALL BE CORED OUT AND AGGREGATE SUBBASE, TYPE B SHALL BE PLACED FOR BASE. THE COST OF CORING OUT THE SIDE ROAD AND ANY AGGREGATE BASE COURSE SHALL BE PAID FOR AS SPECIFIED IN ART. 109.04 OF THE STANDARD SPECIFICATIONS FOR ROAD AND BRIDGE CONSTRUCTION. IF EXISTING SUBBASE IS DETERMINED TO BE ADEQUATE, THE PREPARATION OF THE BASE SHALL BE CONSTRUCTED ACCORDING TO ARTICLE 406.19.
- VARIABLE SHAPING IS INCLUDED IN THE COST OF INCIDENTAL HOT-MIX ASPHALT SURFACE.

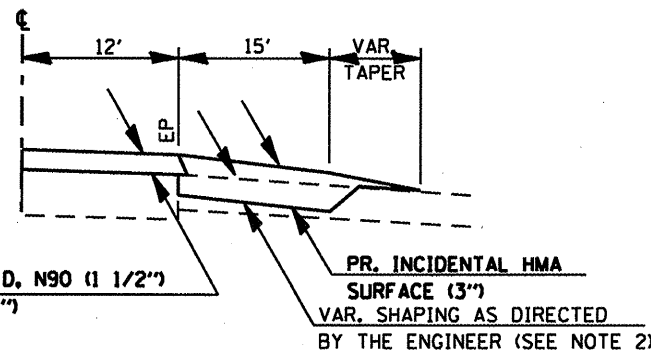

SIDE ROAD SEC. B-B
EX. OIL & CHIP SURFACE
(SEE NOTE 1)

STATE OF ILLINOIS
DEPARTMENT OF TRANSPORTATION

DETAIL: SIDE ROADS
AND ENTRANCES

FILE NAME =	USER NAME = mcoordkr	DESIGNED -	REVISED -
of:\pwork\p\WIDOT\MCCORDKR\j0167663\78157-sh1-plan.dgn		DRAWN -	REVISED -
PLOT SCALE = 108.0000 "/ IN.		CHECKED -	REVISED -
PLOT DATE = 1/25/2010		DATE -	REVISED -

F.A.P. RTE. -322	SECTION -16:IBS-3	COUNTY -PEBBY	TOTAL SHEETS -37	SHEET NO. -34
SCALE: SHEET NO. OF SHEETS STA. TO STA.				CONTRACT NO. 78167
FED. ROAD DIST. NO. ILLINOIS FED. AID PROJECT				