

NOTE:
EXISTING P.C.C. PAVEMENT CONTAINS 2'-6" LONG, 1/2" DIA. BARS AT ALL JOINTS AS WELL AS METAL LONGITUDINAL, TRANSVERSE, EXPANSION & CONTRACTION JOINTS.

STATE STREET
EXISTING TYPICAL SECTION
STA. 5+30.20 TO STA. 31+34.90

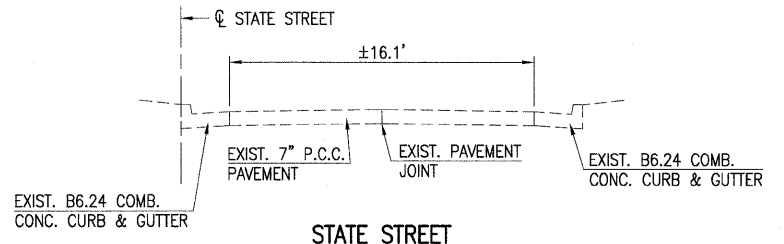

STATE STREET
EXISTING TYPICAL SECTION
STA. 31+34.90 TO STA. 31+53.20

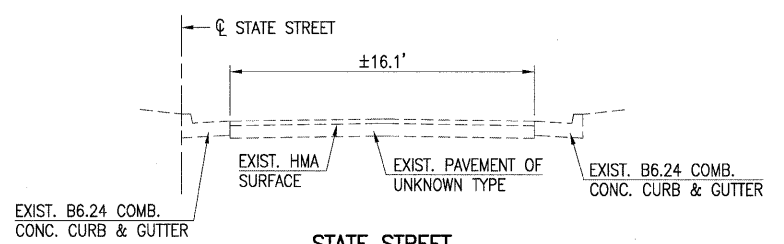

STATE STREET
EXISTING TYPICAL SECTION
STA. 31+53.20 TO STA. 31+95.80

ORIGINAL CONSTRUCTION SECTION: 4 C-S

HOT-MIX ASPHALT MIXTURE REQUIREMENTS

MIXTURE USE	SURFACE LIFT ①	LEVELING BINDER ②
AC/PG	PG 64-22	PG 64-22
DESIGN AIR VOIDS	4% @ N50	4% @ N50
MIXTURE COMPOSITION (GRADATION MIXTURE)	IL-12.5 OR IL-9.5	IL-9.5
FRICITION AGGREGATE	MIX "C"	N/A

- NOTES:
- MAX WEIGHT = 112 lbs/sq yd/in
 - BITUMINOUS PRIME/RC70 (FOG COAT) REQUIRED BETWEEN EACH LIFT.

NOTES

- THE NOMINAL COMPACTED THICKNESS OF BITUMINOUS CONCRETE PAVEMENT IS SHOWN IN THE TYPICAL SECTION. THE CONSTRUCTED THICKNESS SHALL NOT BE LESS THAN 90 PERCENT OF THE NOMINAL THICKNESS AT ANY LOCATION.
- THE PRIME COAT APPLICATION RATE SHALL BE 0.05 TO 0.10 GALLONS PER SQUARE YARD ON EXISTING PAVED SURFACES AND 0.02 GALLONS PER SQUARE YARD (FOG/TACK COAT) ON EACH SUCCESSIVE LIFT HOT-MIX ASPHALT. THE PRIME COAT SHALL BE PAID FOR AT THE UNIT PRICE BID FOR 'BITUMINOUS MATERIALS (PRIME COAT).'
- LEVELING BINDER (HAND METHOD) SHALL BE PLACED IN SPALLED AREAS OR DEPRESSIONS EXCEEDING 1 INCH IN DEPTH AFTER LOOSE PATCH MATERIAL HAS BEEN REMOVED AND THE PAVEMENT HAS BEEN CLEANED OF ALL DEBRIS.
- PERMANENT AND SHORT-TERM CROSS WALK AND STOP BAR PAVEMENT MARKINGS "BY OTHERS."

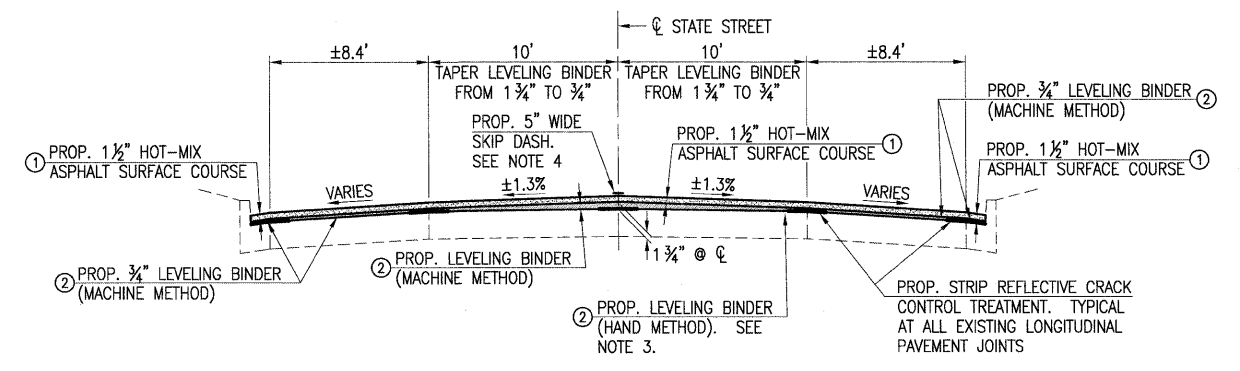

STATE STREET
PROPOSED TYPICAL SECTION
STA. 5+30.20 TO STA. 31+53.20

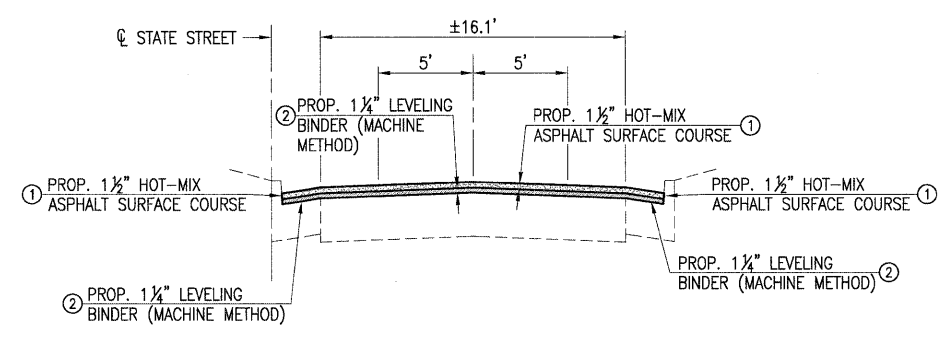

STATE STREET
PROPOSED TYPICAL SECTION
STA. 31+53.20 TO STA. 31+95.80

JAN 29, 2010 1:50 PM I:\09\095\0910077\CADD\ROAD\SHR\4-C-502TYP.DWG



DESIGNED	-	BJB	9/4/09	REVISED	-	LDK	11/04/09
DRAWN	-	BJB	9/4/09	REVISED	-		
CHECKED	-	LDK	10/20/09	REVISED	-		
DATE	-		2/01/2010	REVISED	-		

STATE OF ILLINOIS
DEPARTMENT OF TRANSPORTATION

TYPICAL SECTIONS - STATE STREET		CITY OF LINCOLN		LOGAN COUNTY, ILLINOIS	
SCALE:	PAGE 2 OF 2	STA.	TO STA.		

F.A.U. RT.:	SECTION	COUNTY	TOTAL SHEETS	SHEET NO.
7718	09-00094-00-RS	LOGAN	10	4
CONTRACT NO.			93526	
FED. ROAD DIST. NO.:		ILLINOIS	FED. AID PROJECT	