

**VIEW A-A
ROUND HEAD BOLT**

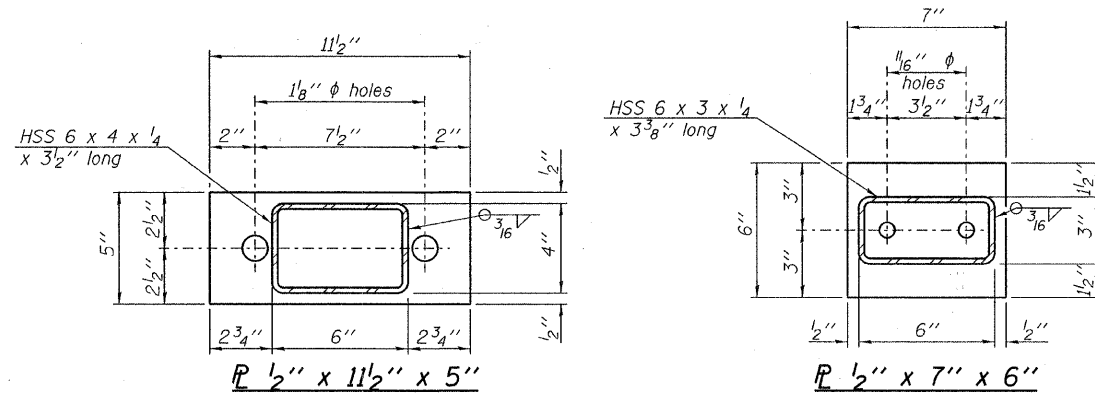

Note: Cost of curled end sections shall be included with the Steel Railing. (4 Required)

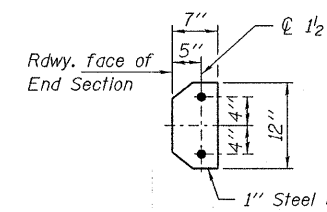

**SECTION E-E
CURLLED END SECTION DETAILS**

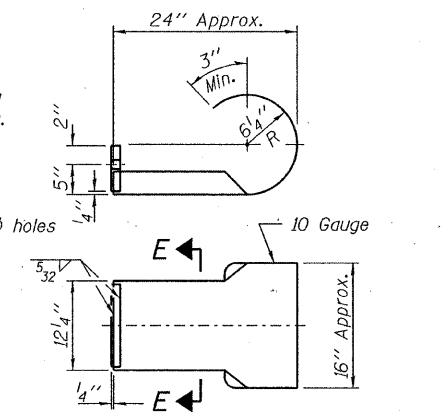

Notes:
All field drilled holes shall be coated with an approved zinc rich paint before erection.
For multi-span bridges, sufficient 1/4 inch x 6 inch x 1/2 inch galvanized steel shims shall be provided to align rail between adjacent spans. Cost included with Steel Railing, Type S-1.
All steel rail elements shall be galvanized according to Article 509.05 of the Standard Specifications.
*** The studs of the anchor devices shall be placed below the top reinforcement bars and the outermost longitudinal reinforcement bar shall be placed directly above the studs of the rail post anchor device.

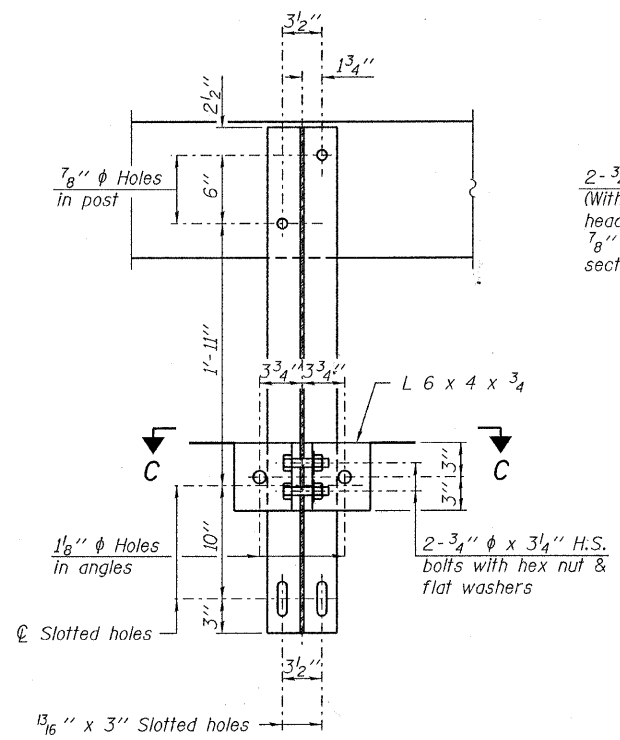

SECTION B-B

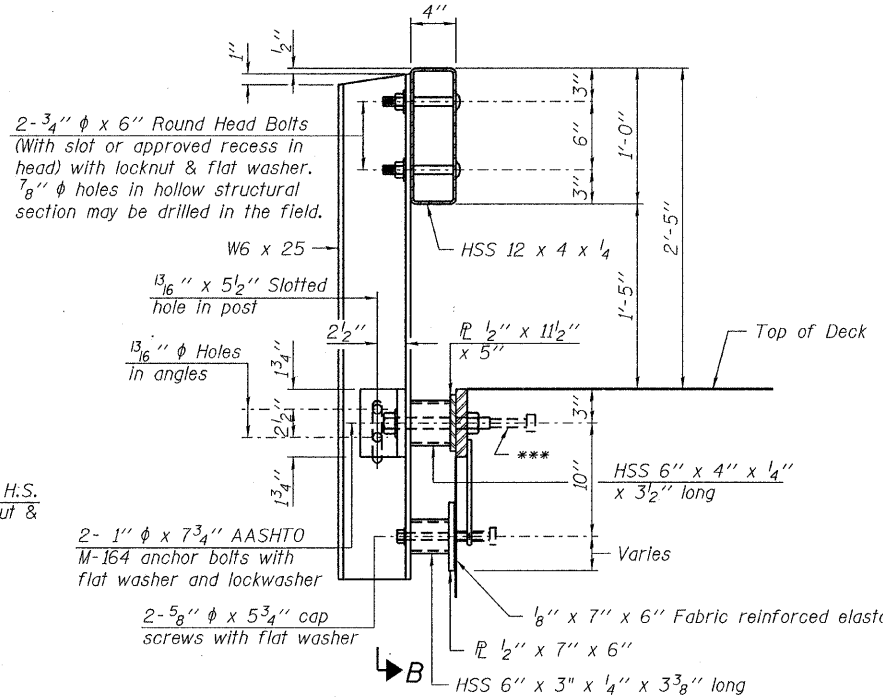

SECTION AT RAILING POST

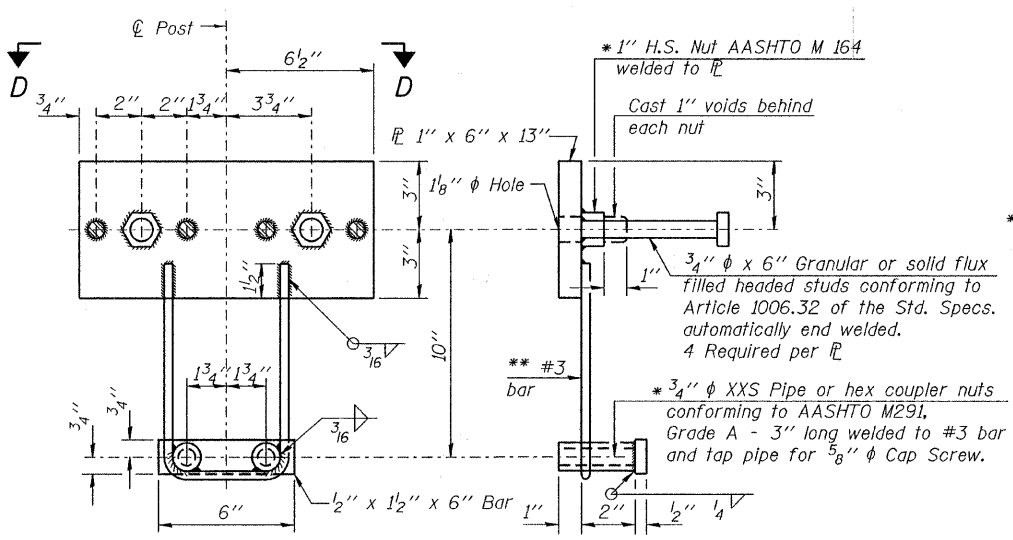

ANCHOR DEVICE

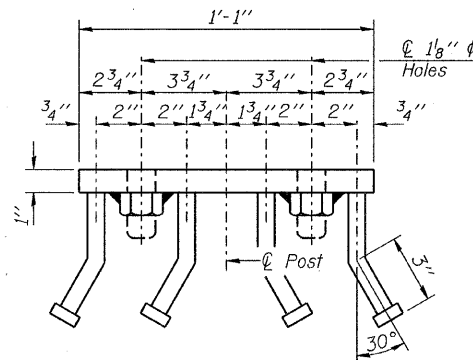

VIEW D-D

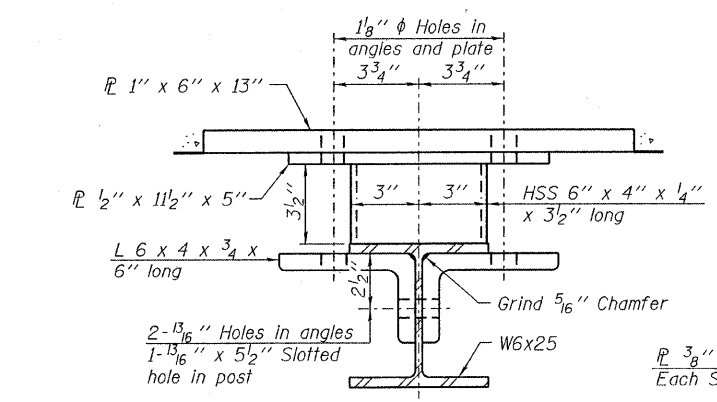

SECTION C-C

** Whenever the lower insert assemblies interfere with strand locations, the #3 bars shall be cut and adjusted in order to allow raising or lowering of the lower inserts. Maximum adjustment not to exceed 1/2 inch.

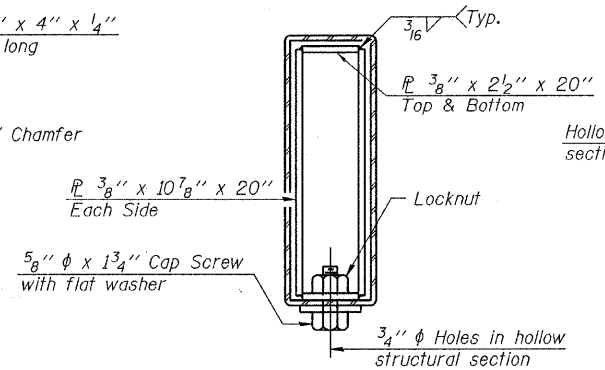

SECTIONS AT RAIL SPLICE

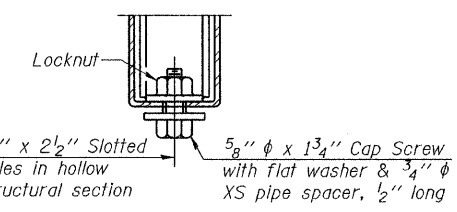

**RAIL SPLICE CONNECTION
AT EXPANSION JT.**

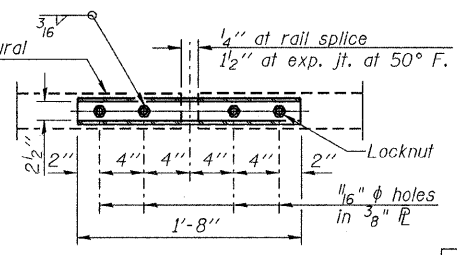

**PLAN-BOTT. SPLICE
TYPICAL**

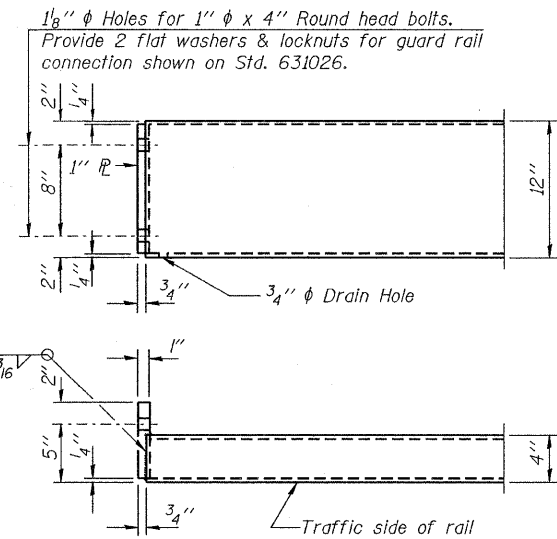

END OF RAIL DETAILS

BILL OF MATERIAL

Item	Unit	Quantity
Steel Railing, Type S-1	Foot	147

**STEEL RAILING, TYPE S-1
STRUCTURE NO. 096-3451**

DESIGNED - A.S.L.
CHECKED - S.W.M.
DRAWN - D.T.M.
CHECKED - D.A.B.

R-23A 10-1-08 (10'-9" Maximum Post Spacing)

HAMPTON, LENZINI AND RENWICK, INC.
CIVIL ENGINEERS - STRUCTURAL ENGINEERS - LAND SURVEYORS
3085 STEVENSON DRIVE, SUITE 201
SPRINGFIELD, ILLINOIS 62703
217.546.3400 www.hlrengineering.com

154 00050
ILLINOIS PROFESSIONAL DESIGN FIRMS / PE / SE CORPORATION
PROJECT NUMBER: 09.0060.130 DATE: 06/22/09

SHEET NO. 5 10 SHEETS	T.R.	SECTION	COUNTY	TOTAL SHEETS	SHEET NO.
	622	08-15143-00-BR	WAYNE	14	9
LEECH ROAD DISTRICT			CONTRACT NO. 95607		
FED. ROAD DIST. NO.		ILLINOIS	FED. AID PROJECT		