

STATE OF ILLINOIS
DEPARTMENT OF TRANSPORTATION

F.A.P. RTE.	SECTION	COUNTY	TOTAL SHEETS	SHEET NO.
303	(134&134X)N	LAKE	129	1
ILLINOIS CONTRACT NO. 60V39				

* 129 + 3 = 132 TOTAL SHEETS

FOR INDEX OF SHEETS, SEE SHEET NO. 2

IMPROVEMENT IS LOCATED IN THE VILLAGE OF ANTIOCH

PROPOSED
HIGHWAY PLANS

FAP ROUTE 303: ILLINOIS ROUTE 173
AT NORTH LAKE AVENUE
SECTION: (134&134X)N
PROJECT: NHPP-F85N(069)
TRAFFIC SIGNAL INSTALLATION & CHANNELIZATION
LAKE COUNTY
C-91-558-12

TRAFFIC DATA (IL 173)
SPEED LIMIT = 40 MPH
ADT = 8,900 - 11,100 (2019)

TRAFFIC DATA (LAKE AVENUE)
SPEED LIMIT = 30 MPH
ADT = 2,250 (2019)



FULL SIZE PLANS HAVE BEEN PREPARED USING STANDARD ENGINEERING SCALES. REDUCED SIZED PLANS WILL NOT CONFORM TO STANDARD SCALES. IN MAKING MEASUREMENTS ON REDUCED PLANS, THE ABOVE SCALES MAY BE USED.

J.U.L.I.E.
JOINT UTILITY LOCATION INFORMATION FOR EXCAVATORS
1-800-892-0123
OR 811

PROJECT ENGINEER: DAN WILGREEN (847) 705-4240
PROJECT MANAGER: FAWAD AQUEEL (847) 705-4247

CONTRACT NO. 60V39

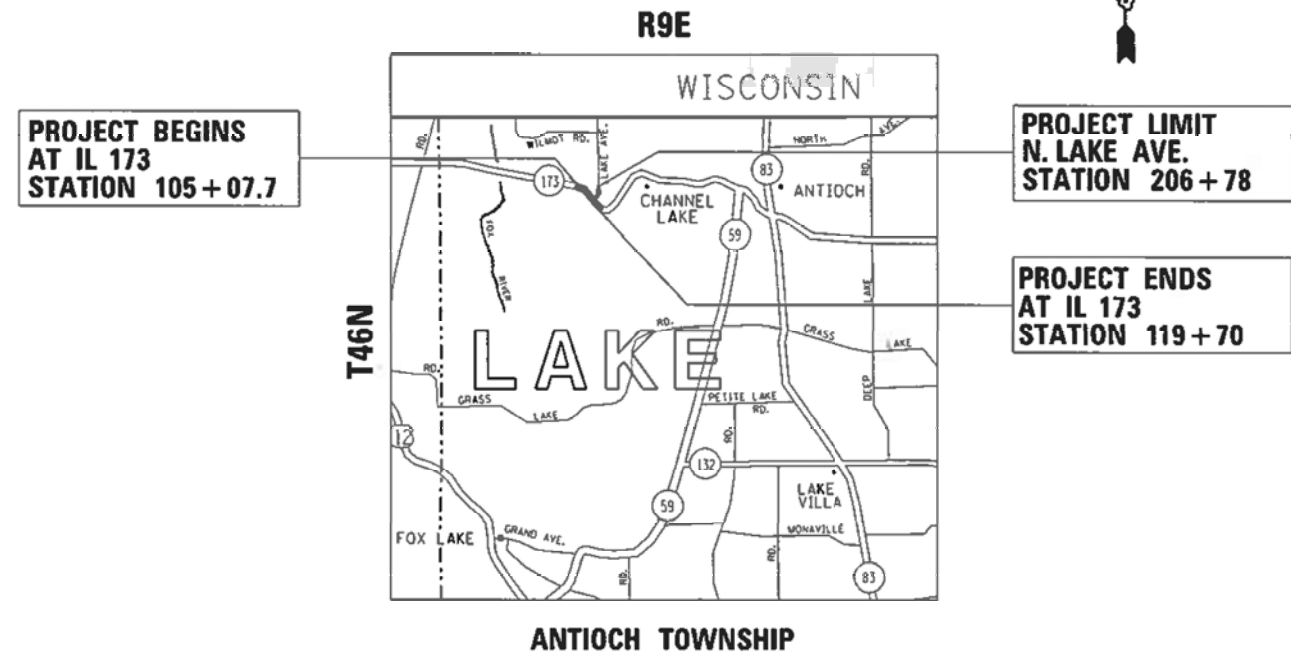

GROSS LENGTH OF IMPROVEMENT = 2,140.3 FT = 0.41 MILES
NET LENGTH OF IMPROVEMENT = 2,140.3 FT = 0.41 MILES

STATE OF ILLINOIS
DEPARTMENT OF TRANSPORTATION

SUBMITTED January 24, 2021

[Signature] REGIONAL ENGINEER

March 19, 2021

[Signature] ENGINEER OF DESIGN AND ENVIRONMENT

March 19, 2021

[Signature] DIRECTOR OF HIGHWAYS PROJECT IMPLEMENTATION

PRINTED BY THE AUTHORITY
OF THE STATE OF ILLINOIS

GENERAL NOTES (CONT):

RESTORATION OF THE TRAFFIC SIGNAL WORK AREA SHALL BE INCLUDED IN THE RELATED PAY ITEM SUCH AS FOUNDATION, CONDUIT, HANDHOLE, ETC., AND NO EXTRA COMPENSATION SHALL BE ALLOWED. ALL ROADWAY SURFACES SUCH AS SHOULDERS, MEDIAN, SIDEWALKS, PAVEMENT ETC. SHALL BE REPLACED IN KIND. ALL DAMAGE TO MOWED LAWNS SHALL BE REPLACED WITH AN APPROVED SOD, AND ALL DAMAGE TO UNMOWED FIELDS SHALL BE SEEDED IN ACCORDANCE WITH STANDARD SPECIFICATIONS 252 AND 250 RESPECTIVELY.

PARTIAL PAYMENT AS DESCRIBED IN ARTICLE 109.07(b) OF THE STANDARD SPECIFICATIONS WILL NOT BE ALLOWED FOR ITEMS INCLUDED IN THIS CONTRACT.

LOCATIONS WITH PEDESTRIAN EQUIPMENT HAVE BEEN DESIGNED TO BE ADA COMPLIANT. ANY DEVIATION FROM THE PLANS FOR TRAFFIC SIGNAL MAST ARM/POSTS THAT HAVE PEDESTRIAN EQUIPMENT WILL HAVE TO BE APPROVED BY THE ENGINEER TO INSURE ADA COMPLIANCE.

PIPE UNDERDRAINS SHALL BE INSTALLED ACCORDING TO SECTION 601 OF THE SSRBC AND STANDARD 601001-05. TOP OF PIPE UNDERDRAINS SHALL BE PLACED MINIMUM 6" BELOW THE AGGREGATE SUBGRADE IMPROVEMENT LAYER. THE COST OF MAKING PIPE UNDERDRAINS CONNECTIONS TO DRAINAGE STRUCTURES SHALL BE INCLUDED IN THE COST OF THE PIPE UNDERDRAINS.

ANY AGGREGATE SUBGRADE IMPROVEMENT CONTAMINATED AND/OR DAMAGED BY THE CONTRACTOR'S VEHICLES AND/OR EQUIPMENTS IS TO BE REMOVED AND REPLACED AS DIRECT BY THE ENGINEER AT CONTRACTOR EXPENSE.

THE SUBGRADE STABILITY SHALL BE VERIFIED BY PROOF ROLLING WITH A FULLY LOADED TAND-AXLE TRUCK.

THE CONTRACTOR SHALL USE CARE IN GRADING OR EXCAVATING NEAR ANY OR ALL EXISTING ITEMS THAT WILL NOT BE REMOVED. ANY DAMAGE DONE TO EXISTING ITEMS BY THE CONTRACTOR SHALL BE REPAIRED AT THE CONTRACTOR'S OWN EXPENSE TO THE SATISFACTION OF THE ENGINEER.

COMMITMENTS:

1. PER REQUIREMENTS SET BY IDNR, NO-INTRUSION/SILT FENCE SHALL BE INSTALLED AS OUTLINED IN THE CONTRACT PLANS TO PREVENT IMPACTS TO THE ADJACENT STATE PARK

MODEL: Default
 FILE NAME: p:\data\mroom.dwg
 ILLINOIS DOT
 PROJECT: P171009\CADD\DATA\Design\171009-rtg-engineer.dwg

USER NAME = kalorm	DESIGNED -	REVISED -
	DRAWN -	REVISED -
PLOT SCALE = 100,0000' / in.	CHECKED -	REVISED -
PLOT DATE = 1/27/2021	DATE -	REVISED -

**STATE OF ILLINOIS
DEPARTMENT OF TRANSPORTATION**

**INDEX OF SHEETS, STATE STANDARDS AND GENERAL NOTES
IL 173 AT NORTH LAKE AVENUE**

SCALE: SHEET 1 OF 1 SHEETS STA. TO STA.

F.A.P. RTE.	SECTION	COUNTY	TOTAL SHEETS	SHEET NO.
303	(134&134X)N	LAKE	129	3
CONTRACT NO. 60V39				
		ILLINOIS	FED. AID PROJECT	

SUMMARY OF QUANTITIES			CONSTRUCTION TYPE CODE						SUMMARY OF QUANTITIES			CONSTRUCTION TYPE CODE								
CODE NO	ITEM	UNIT	TOTAL QUANTITIES URBAN	80% FED 20% STATE ROADWAY 0004	80% FED 13.3% STATE 6.7% LAKE COUNTY T.S. SIG. 0021	100% ANTIOCH FIRE DEPT. EVP 0021	100% LAKE COUNTY T.S. SIG. 0021	80% FED 20% STATE RETAINING WALL 0044	CODE NO	ITEM	UNIT	TOTAL QUANTITIES URBAN	80% FED 20% STATE ROADWAY 0004	80% FED 13.3% STATE 6.7% LAKE COUNTY T.S. SIG. 0021	100% ANTIOCH FIRE DEPT. EVP 0021	100% LAKE COUNTY T.S. SIG. 0021	80% FED 20% STATE RETAINING WALL 0044			
20100110	TREE REMOVAL (6 TO 15 UNITS DIAMETER)	UNIT	386	386					25100115	MULCH, METHOD 2	ACRE	1.43	1.43							
20100210	TREE REMOVAL (OVER 15 UNITS DIAMETER)	UNIT	98	98					* 25100630	EROSION CONTROL BLANKET	SO YD	6897	6897							
20101000	TEMPORARY FENCE	FOOT	1587	1587					28000250	TEMPORARY EROSION CONTROL SEEDING	POUND	142	142							
20101300	TREE PRUNING (1 TO 10 INCH DIAMETER)	EACH	30	30					28000305	TEMPORARY DITCH CHECKS	FOOT	60	60							
20101350	TREE PRUNING (OVER 10 INCH DIAMETER)	EACH	40	40					28000400	PERIMETER EROSION BARRIER	FOOT	1459	1459							
20200100	EARTH EXCAVATION	CU YD	789	789					28000500	INLET AND PIPE PROTECTION	EACH	1	1							
20201200	REMOVAL AND DISPOSAL OF UNSUITABLE MATERIAL	CU YD	706	706					28000510	INLET FILTERS	EACH	14	14							
20400800	FURNISHED EXCAVATION	CU YD	1592.4	1592.4					28100107	STONE RIPRAP, CLASS A4	SO YD	8.8	8.8							
20800150	TRENCH BACKFILL	CU YD	474.7	474.7					28200200	FILTER FABRIC	SO YD	8.8	8.8							
21001000	GEOTECHNICAL FABRIC FOR GROUND STABILIZATION	SO YD	5283	5283					30300001	AGGREGATE SUBGRADE IMPROVEMENT	CU YD	608	608							
21101505	TOPSOIL EXCAVATION AND PLACEMENT	CU YD	1682	1682					30300112	AGGREGATE SUBGRADE IMPROVEMENT 12"	SO YD	3380	3380							
* 25000210	SEEDING, CLASS 2A	ACRE	0.7	0.7					35501308	HOT-MIX ASPHALT BASE COURSE, 6"	SO YD	383	383							
* 25000400	NITROGEN FERTILIZER NUTRIENT	POUND	64.9	64.9					35501314	HOT-MIX ASPHALT BASE COURSE, 7 1/2"	SO YD	83	83							
* 25000600	POTASSIUM FERTILIZER NUTRIENT	POUND	64.9	64.9					35501315	HOT-MIX ASPHALT BASE COURSE, 7 3/4"	SO YD	1742	1742							
									35501316	HOT-MIX ASPHALT BASE COURSE, 8"	SO YD	231	231							
									35600706	HOT-MIX ASPHALT BASE COURSE WIDEING, 7 1/2"	SO YD	378	378							
									* SPECIALTY ITEMS											

FILE NAME =	USER NAME = kalorm	DESIGNED -	REVISED -
pw:\planroom\dtd\illinois\gov\FW1001\Documents\DOT 0\files\District\Projects\P11909\CADD\rd\Design\P11909-sh-50.dwg		DRAWN -	REVISED -
		CHECKED -	REVISED -
		DATE -	REVISED -

**STATE OF ILLINOIS
DEPARTMENT OF TRANSPORTATION**

**IL. ROUTE 173 AT NORTH LAKE ST
SUMMARY OF QUANTITIES**

SCALE: | SHEET NO. OF SHEETS | STA. TO STA.

F.A.P. RTE.	SECTION	COUNTY	TOTAL SHEETS	SHEET NO.
303	(134 & 134X) N	LAKE	129	4
CONTRACT NO. 60V39				
FED. ROAD DIST. NO. 1 (ILLINOIS) FED. AID PROJECT				

REV-SEP

SUMMARY OF QUANTITIES			CONSTRUCTION TYPE CODE					
CODE NO	ITEM	UNIT	TOTAL QUANTITIES URBAN	80% FED 20% STATE ROADWAY 0004	80% FED 13.3% STATE 6.7% LAKE COUNTY T.S. SIG. 0021	100% ANTIOCH FIRE DEPT. EVP 0021	100% LAKE COUNTY T.S. SIG. 0021	80% FED 20% STATE RETAINING WALL 0044
35600707	HOT-MIX ASPHALT BASE COURSE WIDENING, 7 3/4"	SO YD	142	142				
40600290	BITUMINOUS MATERIALS (TACK COAT)	POUND	6880	6880				
40600400	MIXTURE FOR CRACKS, JOINTS, AND FLANGEWAYS	TON	13	13				
40600982	HOT-MIX ASPHALT SURFACE REMOVAL - BUTT JOINT	SO YD	69	69				
40601005	HOT-MIX ASPHALT REPLACEMENT OVER PATCHES	TON	87	87				
40603085	HOT-MIX ASPHALT BINDER COURSE, IL-19.0, N70	TON	209	209				
40603090	HOT-MIX ASPHALT BINDER COURSE, IL-19.0, N90	TON	565	565				
40603200	POLYMERIZED HOT-MIX ASPHALT BINDER COURSE, IL-4.75, N50	TON	365	365				
40604060	HOT-MIX ASPHALT SURFACE COURSE, IL-9.5, MIX "D", N50	TON	69	69				
40604062	HOT-MIX ASPHALT SURFACE COURSE, IL-9.5, MIX "D", N70	TON	487	487				
40605026	POLYMERIZED HOT-MIX ASPHALT SURFACE COURSE, STONE MATRIX ASPHALT, 9.5, MIX "F", N80	TON	824	824				
42001300	PROTECTIVE COAT	SO YD	858	858				

SUMMARY OF QUANTITIES			CONSTRUCTION TYPE CODE					
CODE NO	ITEM	UNIT	TOTAL QUANTITIES URBAN	80% FED 20% STATE ROADWAY 0004	80% FED 13.3% STATE 6.7% LAKE COUNTY T.S. SIG. 0021	100% ANTIOCH FIRE DEPT. EVP 0021	100% LAKE COUNTY T.S. SIG. 0021	80% FED 20% STATE RETAINING WALL 0044
42300200	PORTLAND CEMENT CONCRETE DRIVEWAY PAVEMENT, 6 INCH	SO YD	151	151				
44000159	HOT-MIX ASPHALT SURFACE REMOVAL, 2 1/2"	SO YD	1723	1723				
44000200	DRIVEWAY PAVEMENT REMOVAL	SO YD	1260	1260				
44000500	COMBINATION CURB AND GUTTER REMOVAL	FOOT	1891	1891				
44004250	PAVED SHOULDER REMOVAL	SO YD	1362	1362				
44002232	HOT MIX ASPHALT REMOVAL OVER PATCHES, 8"	SQ YD	193	193				
44201692	CLASS D PATCHES, TYPE II, 4 INCH	SO YD	73	73				
44201694	CLASS D PATCHES, TYPE III, 4 INCH	SO YD	57	57				
44201741	CLASS D PATCHES, TYPE II, 8 INCH	SO YD	167	167				
48101620	AGGREGATE SHOULDER, TYPE B 10"	SQ YD	68.4	68.4				
50104400	CONCRETE HEADWALL REMOVAL	EACH	2	2				
50105220	PIPE CULVERT REMOVAL	FOOT	133	133				
50300225	CONCRETE STRUCTURES	CU YD	0.9					0.9
50500505	STUD SHEAR CONNECTORS	EACH	10					10
50800205	REINFORCEMENT BARS, EPOXY COATED	POUND	80					80
52200015	PERMANENT SHEET PILING	SO FT	42172					42172

* SPECIALTY ITEMS

SUMMARY OF QUANTITIES			CONSTRUCTION TYPE CODE					
CODE NO	ITEM	UNIT	TOTAL QUANTITIES URBAN	80% FED 20% STATE ROADWAY 0004	80% FED 13.3% STATE 6.7% LAKE COUNTY T.S. SIG. 0021	100% ANTIOCH FIRE DEPT. EVP 0021	100% LAKE COUNTY T.S. SIG. 0021	80% FED 20% STATE RETAINING WALL 0044
54213657	PRECAST REINFORCED CONCRETE FLARED END SECTIONS 12"	EACH	2	2				
54213660	PRECAST REINFORCED CONCRETE FLARED END SECTIONS 15"	EACH	4	4				
54261224	CONCRETE END SECTION, STANDARD 542001, 24", 1:2	EACH	2	2				
542A0217	PIPE CULVERTS, CLASS A, TYPE 1 12"	FOOT	40	40				
542A0220	PIPE CULVERTS, CLASS A, TYPE 1 15"	FOOT	64	64				
550A0050	STORM SEWERS, CLASS A, TYPE 1 12"	FOOT	63.8	63.8				
550A0340	STORM SEWERS, CLASS A, TYPE 2 12"	FOOT	385	385				
550A0360	STORM SEWERS, CLASS A, TYPE 2 15"	FOOT	95	95				
550A0380	STORM SEWERS, CLASS A, TYPE 2 18"	FOOT	381.2	381.2				
550A0410	STORM SEWERS, CLASS A, TYPE 2 24"	FOOT	212	212				
550A0710	STORM SEWERS, CLASS A, TYPE 3 24"	FOOT	76	76				
55100500	STORM SEWER REMOVAL 12"	FOOT	564	564				
60100060	CONCRETE HEADWALLS FOR PIPE DRAINS	EACH	2	2				
60108100	PIPE UNDERDRAINS 4" (SPECIAL)	FOOT	60	60				

SUMMARY OF QUANTITIES			CONSTRUCTION TYPE CODE					
CODE NO	ITEM	UNIT	TOTAL QUANTITIES URBAN	80% FED 20% STATE ROADWAY 0004	80% FED 13.3% STATE 6.7% LAKE COUNTY T.S. SIG. 0021	100% ANTIOCH FIRE DEPT. EVP 0021	100% LAKE COUNTY T.S. SIG. 0021	80% FED 20% STATE RETAINING WALL 0044
60108204	PIPE UNDERDRAINS, TYPE 2, 4"	FOOT	1830	1830				
60200205	CATCH BASINS, TYPE A, 4'-DIAMETER, TYPE 1 FRAME, CLOSED LID	EACH	1	1				
60200805	CATCH BASINS, TYPE A, 4'-DIAMETER, TYPE 8 GRATE	EACH	3	3				
60206905	CATCH BASINS, TYPE C, TYPE 1 FRAME, OPEN LID	EACH	1	1				
60208240	CATCH BASINS, TYPE C, TYPE 24 FRAME AND GRATE	EACH	5	5				
60218400	MANHOLES, TYPE A, 4'-DIAMETER, TYPE 1 FRAME, CLOSED LID	EACH	8	8				
60223800	MANHOLES, TYPE A, 6'-DIAMETER, TYPE 1 FRAME, CLOSED LID	EACH	1	1				
60234200	INLETS, TYPE A, TYPE 1 FRAME, OPEN LID	EACH	1	1				
60236200	INLETS, TYPE A, TYPE 8 GRATE	EACH	1	1				
60237470	INLETS, TYPE A, TYPE 24 FRAME AND GRATE	EACH	3	3				
60300350	MANHOLE FRAMES TO BE ADJUSTED	EACH	1	1				
60406100	FRAMES AND LIDS, TYPE 1, CLOSED LID	EACH	2	2				

* SPECIALTY ITEMS

SUMMARY OF QUANTITIES				CONSTRUCTION TYPE CODE					
CODE NO	ITEM	UNIT	TOTAL QUANTITIES URBAN	80% FED 20% STATE ROADWAY 0004	80% FED 13.3% STATE 6.7% LAKE COUNTY T.S. SIG. 0021	100% ANTIOCH FIRE DEPT. EVP 0021	100% LAKE COUNTY T.S. SIG. 0021	80% FED 20% STATE RETAINING WALL 0044	
60500040	REMOVING MANHOLES	EACH	2	2					
60500060	REMOVING INLETS	EACH	5	5					
60603100	CONCRETE GUTTER TRANSITION	FOOT	88.2	88.2					
60603800	COMBINATION CONCRETE CURB AND GUTTER, TYPE B-6.12	FOOT	117	117					
60605000	COMBINATION CONCRETE CURB AND GUTTER, TYPE B-6.24	FOOT	1882	1882					
* 63000003	STEEL PLATE BEAM GUARDRAIL, TYPE A, 9 FOOT POSTS	FOOT	1263.48	1263.48					
* 63100167	TRAFFIC BARRIER TERMINAL, TYPE 1 (SPECIAL) TANGENT	EACH	3	3					
63200310	GUARDRAIL REMOVAL	FOOT	1400	1400					
* 66900200	NON-SPECIAL WASTE DISPOSAL	CU YD	1265	1265					
* 66900530	SOIL DISPOSAL ANALYSIS	EACH	5	5					
* 66901001	REGULATED SUBSTANCES PRE-CONSTRUCTION PLAN	LSUM	1	1					
* 66901003	REGULATED SUBSTANCES FINAL CONSTRUCTION REPORT	LSUM	1	1					
* 66901006	REGULATED SUBSTANCES MONITORING	CAL DA	30	30					

SUMMARY OF QUANTITIES				CONSTRUCTION TYPE CODE					
CODE NO	ITEM	UNIT	TOTAL QUANTITIES URBAN	80% FED 20% STATE ROADWAY 0004	80% FED 13.3% STATE 6.7% LAKE COUNTY T.S. SIG. 0021	100% ANTIOCH FIRE DEPT. EVP 0021	100% LAKE COUNTY T.S. SIG. 0021	80% FED 20% STATE RETAINING WALL 0044	
67000400	ENGINEER'S FIELD OFFICE, TYPE A	CAL MO	15	15					
67100100	MOBILIZATION	L SUM	1	1					
70107025	CHANGEABLE MESSAGE SIGN	CAL DA	60		60				
70300100	SHORT TERM PAVEMENT MARKING	FOOT	8189	8189					
70300150	SHORT TERM PAVEMENT MARKING REMOVAL	SO FT	683	683					
70300210	TEMPORARY PAVEMENT MARKING LETTERS AND SYMBOLS	SO FT	310	310					
70300220	TEMPORARY PAVEMENT MARKING - LINE 4"	FOOT	11984	11984					
70300240	TEMPORARY PAVEMENT MARKING - LINE 6"	FOOT	825	825					
70300260	TEMPORARY PAVEMENT MARKING - LINE 12"	FOOT	576	576					
70300280	TEMPORARY PAVEMENT MARKING - LINE 24"	FOOT	93	93					
70300520	PAVEMENT MARKING TAPE, TYPE III 4"	FOOT	2048	2048					
70300904	PAVEMENT MARKING TAPE, TYPE IV 4"	FOOT	13905	13905					
70300924	PAVEMENT MARKING TAPE, TYPE IV 24"	FOOT	31	31					
* 72000100	SIGN PANEL - TYPE 1	SO FT	240.6	215.1	25.5				
* 72400100	REMOVE SIGN PANEL ASSEMBLY - TYPE A	EACH	18	18					
* 72400200	REMOVE SIGN PANEL ASSEMBLY - TYPE B	EACH	6	6					

* SPECIALTY ITEMS

SUMMARY OF QUANTITIES				CONSTRUCTION TYPE CODE						SUMMARY OF QUANTITIES				CONSTRUCTION TYPE CODE					
CODE NO	ITEM	UNIT	TOTAL QUANTITIES URBAN	80% FED 20% STATE ROADWAY 0004	80% FED 13.3% STATE 6.7% LAKE COUNTY T.S. SIG. 0021	100% ANTIOCH FIRE DEPT. EVP 0021	100% LAKE COUNTY T.S. SIG. 0021	80% FED 20% STATE RETAINING WALL 0044	CODE NO	ITEM	UNIT	TOTAL QUANTITIES URBAN	80% FED 20% STATE ROADWAY 0004	80% FED 13.3% STATE 6.7% LAKE COUNTY T.S. SIG. 0021	100% ANTIOCH FIRE DEPT. EVP 0021	100% LAKE COUNTY T.S. SIG. 0021	80% FED 20% STATE RETAINING WALL 0044		
72501000	TERMINAL MARKER - DIRECT APPLIED	EACH	3	3					* 81028200	UNDERGROUND CONDUIT, GALVANIZED STEEL, 2" DIA.	FOOT	600		600					
* 72800100	TELESCOPING STEEL SIGN SUPPORT	FOOT	491	491					* 81028220	UNDERGROUND CONDUIT, GALVANIZED STEEL, 3" DIA.	FOOT	141		141					
* 78000100	THERMOPLASTIC PAVEMENT MARKING - LETTERS AND SYMBOLS	SO FT	155	155					* 81028240	UNDERGROUND CONDUIT, GALVANIZED STEEL, 4" DIA.	FOOT	229		229					
* 78000200	THERMOPLASTIC PAVEMENT MARKING - LINE 4"	FOOT	8631	8631					* 81400100	HANDHOLE	EACH	2		2					
* 78000400	THERMOPLASTIC PAVEMENT MARKING - LINE 6"	FOOT	513	513					* 81400200	HEAVY-DUTY HANDHOLE	EACH	4		4					
* 78000600	THERMOPLASTIC PAVEMENT MARKING - LINE 12"	FOOT	542	542					* 81400300	DOUBLE HANDHOLE	EACH	1		1					
* 78000650	THERMOPLASTIC PAVEMENT MARKING - LINE 24"	FOOT	53	53					* 87301225	ELECTRIC CABLE IN CONDUIT, SIGNAL NO. 14 3C	FOOT	260		260					
* 78100100	RAISED REFLECTIVE PAVEMENT MARKER	EACH	84	84					* 87301245	ELECTRIC CABLE IN CONDUIT, SIGNAL NO. 14 5C	FOOT	1190		1190					
	78100300 REPLACEMENT REFLECTORS	EACH	30	30															
* 78200006	GUARDRAIL REFLECTORS, TYPE B	EACH	17	17					* 87301255	ELECTRIC CABLE IN CONDUIT, SIGNAL NO. 14 7C	FOOT	720		720					
	78300200 RAISED REFLECTIVE PAVEMENT MARKER REMOVAL	EACH	90	90					* 87301305	ELECTRIC CABLE IN CONDUIT, LEAD-IN, NO. 14 1 PAIR	FOOT	930		930					
	78300201 PAVEMENT MARKING REMOVAL - GRINDING	SO FT	2309	2309					* 87301805	ELECTRIC CABLE IN CONDUIT, SERVICE, NO. 6 2 C	FOOT	65		65					
	78300202 PAVEMENT MARKING REMOVAL - WATER BLASTING	SO FT	667	667															
									* SPECIALTY ITEMS										

FILE NAME =	USER NAME = kalorm	DESIGNED -	REVISED -
dw:\planroom\dtd\illinois\gov\PI1909\Documents\DOT 01\files\electrical\Projects\PI1909\CAD\data\Design\PI1909-sh-50.dwg		DRAWN -	REVISED -
	PLOT SCALE = 100.0000' / 1in.	CHECKED -	REVISED -
	PLOT DATE = 1/27/2021	DATE -	REVISED -

**STATE OF ILLINOIS
DEPARTMENT OF TRANSPORTATION**

**IL. ROUTE 173 AT NORTH LAKE ST
SUMMARY OF QUANTITIES**

SCALE: | SHEET NO. OF SHEETS | STA. TO STA.

F.A.P. RTE.	SECTION	COUNTY	TOTAL SHEETS	SHEET NO.
303	(134 & 134XIN)	LAKE	129	B
CONTRACT NO. 60V39				
FED. ROAD DIST. NO. 1 (ILLINOIS) FED. AID PROJECT				

REV-SEP

SUMMARY OF QUANTITIES			CONSTRUCTION TYPE CODE						SUMMARY OF QUANTITIES			CONSTRUCTION TYPE CODE					
CODE NO	ITEM	UNIT	TOTAL QUANTITIES URBAN	80% FED 20% STATE ROADWAY 0004	80% FED 13.3% STATE 6.7% LAKE COUNTY T.S. SIG. 0021	100% ANTIOCH FIRE DEPT. EVP 0021	100% LAKE COUNTY T.S. SIG. 0021	80% FED 20% STATE RETAINING WALL 0044	CODE NO	ITEM	UNIT	TOTAL QUANTITIES URBAN	80% FED 20% STATE ROADWAY 0004	80% FED 13.3% STATE 6.7% LAKE COUNTY T.S. SIG. 0021	100% ANTIOCH FIRE DEPT. EVP 0021	100% LAKE COUNTY T.S. SIG. 0021	80% FED 20% STATE RETAINING WALL 0044
* 87301900	ELECTRIC CABLE IN CONDUIT, EQUIPMENT	FOOT	753		753				* 88030050	SIGNAL HEAD, LED, 1-FACE, 3-SECTION, BRACKET MOUNTED	EACH	4		4			
	GROUNDING CONDUCTOR, NO. 6 1C																
* 87502500	TRAFFIC SIGNAL POST, GALVANIZED STEEL	EACH	2		2				* 88030100	SIGNAL HEAD, LED, 1-FACE, 5-SECTION, BRACKET MOUNTED	EACH	2		2			
	16 FT.																
* 87502520	TRAFFIC SIGNAL POST, GALVANIZED STEEL	EACH	1			1			* 88030110	SIGNAL HEAD, LED, 1-FACE, 5-SECTION, MAST-ARM MOUNTED	EACH	2		2			
	18 FT.																
* 87700180	STEEL MAST ARM ASSEMBLY AND POLE, 28 FT.	EACH	1		1				* 88200410	TRAFFIC SIGNAL BACKPLATE, LOUVERED, FORMED PLASTIC	EACH	6		6			
* 87700230	STEEL MAST ARM ASSEMBLY AND POLE, 38 FT.	EACH	1		1				* 88500100	INDUCTIVE LOOP DETECTOR	EACH	5		5			
* 87702970	STEEL COMBINATION MAST ARM ASSEMBLY AND POLE 48 FT.	EACH	1		1				* 88600100	DETECTOR LOOP, TYPE I	FOOT	395		395			
* 87800100	CONCRETE FOUNDATION, TYPE A	FOOT	16		16				* 88700200	LIGHT DETECTOR	EACH	3			3		
* 87800150	CONCRETE FOUNDATION, TYPE C	FOOT	4		4				* 88700300	LIGHT DETECTOR AMPLIFIER	EACH	1			1		
* 87800400	CONCRETE FOUNDATION, TYPE E 30-INCH DIAMETER	FOOT	13		13				* A2005116	TREE, JUGLANS NIGRA (BLACK WALNUT), 2" CALIPER, BALLED AND BURLAPPED	EACH	3	3				
* 87800415	CONCRETE FOUNDATION, TYPE E 36-INCH DIAMETER	FOOT	27		27				* C2C01424	SHRUB, CORNUS AMOMUM (SILKY DOGWOOD), 2' HEIGHT, CONTAINER	EACH	100	100				
* 88030020	SIGNAL HEAD, LED, 1-FACE, 3-SECTION, MAST-ARM MOUNTED	EACH	4		4				* C2C01524	SHRUB, CORNUS RACEMOSA (GREY DOGWOOD), 2' HEIGHT, CONTAINER	EACH	100	100				
									* SPECIALTY ITEMS								

SUMMARY OF QUANTITIES			CONSTRUCTION TYPE CODE					
CODE NO	ITEM	UNIT	TOTAL QUANTITIES URBAN	80% FED 20% STATE ROADWAY 0004	80% FED 13.3% STATE 6.7% LAKE COUNTY T.S. SIG. 0021	100% ANTIOCH FIRE DEPT. EVP 0021	100% LAKE COUNTY T.S. SIG. 0021	80% FED 20% STATE RETAINING WALL 0044
* C2C09624	SHRUB, SAMBUCUS CANADENSIS (AMERICAN ELDER), 2' HEIGHT, CONTAINER	EACH	225	225				
* C3006024	SHRUB, RHUS TYPHINA (STAGHORN SUMAC), 2' HEIGHT, BARE ROOT	EACH	120	120				
K1004595	PRUNING FOR SAFETY AND EQUIPMENT CLEARANCE	L SUM	1	1				
* X0324085	EMERGENCY VEHICLE PRIORITY SYSTEM LINE SENSOR CABLE, NO. 20 3/C	FOOT	682			682		
* X0325922	CELLULAR MODEM	EACH	1				1	
X0327301	RELOCATE EXISTING MAILBOX	EACH	8	8				
X0900075	COFFERDAM (TYPE 1) IN-STEAM /WETLAND WORK)	EACH	2	2				
* X1400102	OUTDOOR RATED NETWORK CABLE	FOOT	92				92	
* X1400107	FULL-ACTUATED CONTROLLER AND TYPE SUPER P CABINET	EACH	1		1			
* X1400150	SERVICE INSTALLATION, GROUND MOUNTED, METERED	EACH	1		1			
* X2501800	SEEDING, CLASS 4 (MODIFIED)	ACRE	0.73	0.73				
* X2700016	GROOVED THERMOPLASTIC PAVEMENT MARKING- LETTERS AND SYMBOLS	SO FT	155	155				

SUMMARY OF QUANTITIES			CONSTRUCTION TYPE CODE					
CODE NO	ITEM	UNIT	TOTAL QUANTITIES URBAN	80% FED 20% STATE ROADWAY 0004	80% FED 13.3% STATE 6.7% LAKE COUNTY T.S. SIG. 0021	100% ANTIOCH FIRE DEPT. EVP 0021	100% LAKE COUNTY T.S. SIG. 0021	80% FED 20% STATE RETAINING WALL 0044
* X2700017	GROOVED THERMOPLASTIC PAVEMENT MARKING- LINE 4"	FOOT	3353	3353				
* X2700018	GROOVED THERMOPLASTIC PAVEMENT MARKING- LINE 6"	FOOT	312	312				
* X2700019	GROOVED THERMOPLASTIC PAVEMENT MARKING- LINE 12"	FOOT	34	34				
* X2700020	GROOVED THERMOPLASTIC PAVEMENT MARKING- LINE 24"	FOOT	40	40				
X4021000	TEMPORARY ACCESS (PRIVATE ENTRANCE)	EACH	9	9				
X4022000	TEMPORARY ACCESS (COMMERCIAL ENTRANCE)	EACH	2	2				
X4401198	HOT-MIX ASPHALT SURFACE REMOVAL, VARIABLE DEPTH	SO YD	3394	3394				
X7010216	TRAFFIC CONTROL AND PROTECTION, (SPECIAL)	L SUM	1	1				
X7030005	TEMPORARY PAVEMENT MARKING REMOVAL	SO FT	10797	10797				
* X7240505	RELOCATE SIGN PANEL AND POST	EACH	8	8				
X7810300	RECESSED REFLECTIVE PAVEMENT MARKER	EACH	42	42				
* X8620200	UNINTERRUPTABLE POWER SUPPLY, SPECIAL	EACH	1		1			

* SPECIALTY ITEMS

SUMMARY OF QUANTITIES			CONSTRUCTION TYPE CODE					
CODE NO	ITEM	UNIT	TOTAL QUANTITIES URBAN	80% FED 20% STATE ROADWAY 0004	80% FED 13.3% STATE 6.7% LAKE COUNTY T.S. SIG. 0021	100% ANTIOCH FIRE DEPT. EVP 0021	100% LAKE COUNTY T.S. SIG. 0021	80% FED 20% STATE RETAINING WALL 0044
* X1400439	REMOTE CONTROLLER VIDEO SYSTEM	EACH	1				1	
Z0013798	CONSTRUCTION LAYOUT	L SUM	1	1				
Z0030850	TEMPORARY INFORMATION SIGNING	SO FT	214.6	214.6				
Z0033700	LONGITUDINAL JOINT SEALANT	FOOT	2140.3	2140.3				
X1200050	BOX CULVERT REMOVAL	FOOT	57.4	57.4				
Ø Z0076600	TRAINEES	HOURS	500	500				
Ø Z0076604	TRAINEES - TRAINING GRADUATE PROGRAM	HOURS	500	500				

SUMMARY OF QUANTITIES			CONSTRUCTION TYPE CODE					
CODE NO	ITEM	UNIT	TOTAL QUANTITIES URBAN	80% FED 20% STATE ROADWAY 0004	80% FED 13.3% STATE 6.7% LAKE COUNTY T.S. SIG. 0021	100% ANTIOCH FIRE DEPT. EVP 0021	100% LAKE COUNTY T.S. SIG. 0021	80% FED 20% STATE RETAINING WALL 0044
* SPECIALTY ITEMS								

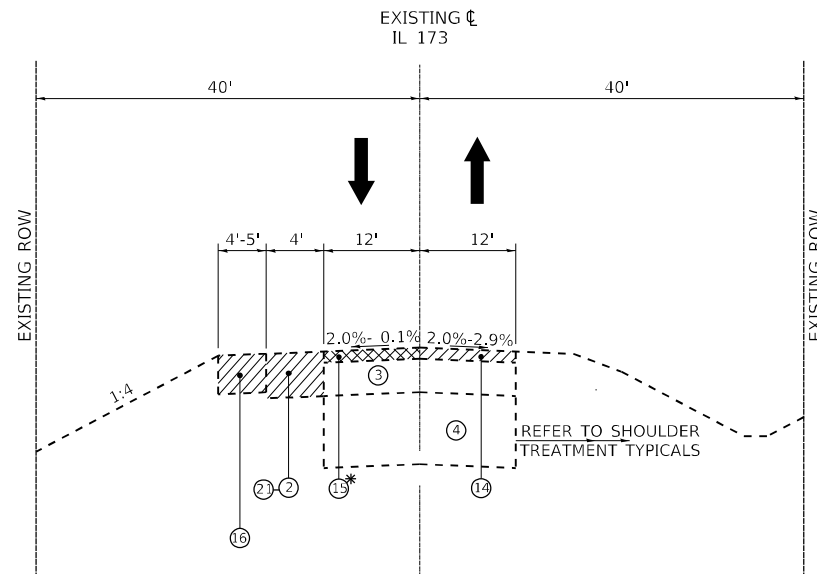

**EXISTING TYPICAL SECTION
ILLINOIS ROUTE 173**
STA. 105+07.7 TO STA 106+42
(LOOKING EAST)
CROWN SECTION

•REFER TO MILLING TABLE

- VARIABLE DEPTH MILLING
- CONSTANT DEPTH MILLING/
OR AGGREGATE SHOULDER REMOVAL

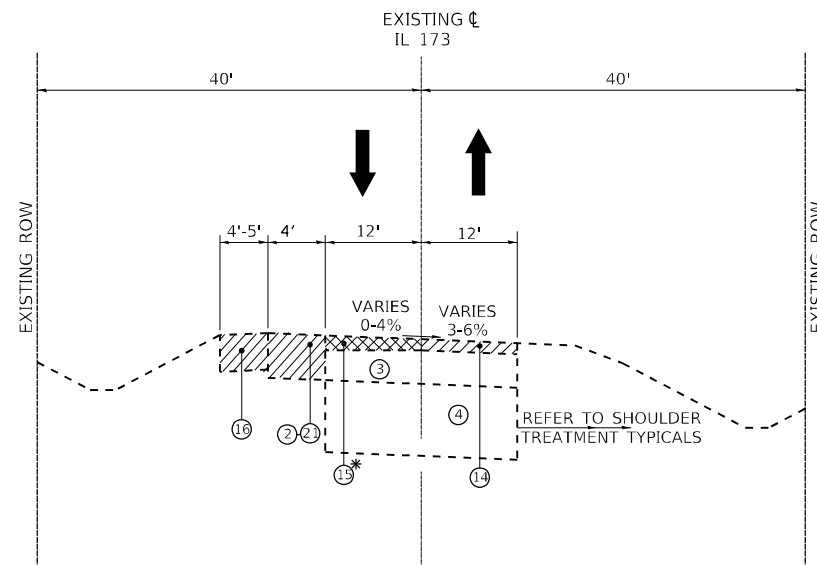

**EXISTING TYPICAL SECTION
ILLINOIS ROUTE 173**
STA. 106+42 TO STA 109+40
(LOOKING EAST)
SUPERELEVATED SECTION

LEGEND:

- ① EXISTING AGGREGATE SHOULDER
- ② EXISTING HOT-MIX ASPHALT SHOULDER, 8"
- ③ EXISTING HOT-MIX ASPHALT OVERLAY, 8"
- ④ EXISTING PCC PAVEMENT, 7.5"
- ⑤ EXISTING CURB AND GUTTER
- ⑥ EXISTING HMA PAVEMENT, 4 1/4"
- ⑦ PROPOSED POLYMERIZED HMA SURFACE COURSE, SMA, 9.5, MIX "F", N 80, 1 3/4"
- ⑧ PROPOSED HMA SURFACE COURSE, IL-9.5, MIX "D", N 70, 1 3/4"
- ⑨ PROPOSED HMA BASE COURSE OR BASE COURSE WIDENING, 7 3/4"
- ⑨A PROPOSED HMA BASE COURSE OR BASE COURSE WIDENING, 7 1/2"
- ⑩ PROPOSED AGGREGATE SUBGRADE IMPROVEMENT, 12"
- ⑪ PROPOSED POLYMERIZED HMA BINDER COURSE, IL-4.75, N50, 3/4"
- ⑫ PROPOSED COMBINATION CURB AND GUTTER, TYPE B 6.24
- ⑬ PROPOSED COMBINATION CURB AND GUTTER, TYPE B 6.12
- ⑭ PROPOSED HOT-MIX ASPHALT SURFACE REMOVAL, 2 1/2"
- *⑮ PROPOSED HOT-MIX ASPHALT SURFACE REMOVAL, VARIABLE DEPTH
- ⑯ PROPOSED AGGREGATE SHOULDER REMOVAL, TO BE PAID FOR AS "REMOVAL AND DISPOSAL OF UNSUITABLE MATERIAL"
- ⑰ PROPOSED GEOTECHNICAL FABRIC FOR GROUND STABILIZATION
- ⑱ PROPOSED HMA BINDER COURSE, IL-19.0, N90, 5 1/2"
- ⑱A PROPOSED HMA BINDER COURSE, IL-19.0, N90, VARIABLE DEPTH
- ⑲ PROPOSED HMA BINDER COURSE, IL-19.0, N70, VARIABLE DEPTH
- ⑳ PROPOSED PIPE UNDERDRAINS, TYPE 2, 4"
- ㉑ PROPOSED PAVED SHOULDER REMOVAL
- ㉒ PROPOSED AGGREGATE SHOULDER, TYPE B 10"
- ㉓ PROPOSED CURB AND GUTTER REMOVAL

PROPOSED UNDERCUTS	
STATION & OFFSET	REMEDIAL TREATMENT
109+00 TO 113+00 LEFT WIDENING	24" ASI

NOTE: CONTRACTOR SHALL PATCH BEFORE MILLING DUE TO THIN PAVEMENT.

HOT-MIX ASPHALT MIXTURE REQUIREMENTS		
MIXTURE TYPE	AIR VOID @ N _{ES}	QUALITY MANAGEMENT PROGRAM (QMP)
RESURFACING, PAVEMENT WIDENING, AND SHOULDERS (IL 173)		
POLYMERIZED HOT-MIX ASPHALT SURFACE COURSE, SMA, 9.5, MIX "F", N80; 1 3/4"	3.5% @ 80 GYR	QC/QA
POLYMERIZED HOT-MIX ASPHALT BINDER COURSE, IL-4.75, N50; 3/4"	3.5% @ 50 GYR	QC/QA
HOT-MIX ASPHALT BASE COURSE, 7 3/4 " (HMA BINDER IL-19.0)	4% @ 90 GYR	QC/QA
HOT-MIX ASPHALT BASE COURSE WIDENING, 7 3/4 " (HMA BINDER IL-19.0)	4% @ 90 GYR	QC/QA
HOT-MIX ASPHALT BINDER COURSE, IL-19.0, N90; 5 1/2 "	4% @ 90 GYR	QC/QA
RESURFACING AND WIDENING (NORTH LAKE AVE.)		
HOT-MIX ASPHALT SURFACE COURSE, MIX "D", IL 9.5; N70, 1 3/4"	4% @ 70 GYR	QC/QA
HOT-MIX ASPHALT BASE COURSE, 7 1/2 " (HMA BINDER IL-19.0)	4% @ 70 GYR	QC/QA
HOT-MIX ASPHALT BASE COURSE WIDENING, 7 1/2 " (HMA BINDER IL-19.0)	4% @ 70 GYR	QC/QA
GRADE CORRECTION		
HOT-MIX ASPHALT BINDER COURSE, IL-19.0, N90 (IL 173); VARIABLE DEPTH (2 1/4" MIN)	4% @ 90 GYR	QC/QA
HOT-MIX ASPHALT BINDER COURSE, IL-19.0, N70 (N LAKE AVE); VARIABLE DEPTH (2 1/4" MIN)	4% @ 70 GYR	QC/QA
DRIVEWAYS		
HOT-MIX ASPHALT SURFACE COURSE, MIX D, N50 (IL 9.5 mm); 2"	4% @ 50 GYR	QC/QA
HOT-MIX ASPHALT BASE COURSE (HMA BINDER IL-19 mm); CE 8", PE 6"	4% @ 50 GYR	QC/QA
PATCHING		
CLASS D PATCHES (HMA BINDER IL-19 mm)	4% @ 70 GYR	QC/QA
HOT-MIX ASPHALT REPLACEMENT OVER PATCHES (HMA BINDER IL-19 mm)	4% @ 70 GYR	QC/QA
QMP Designation: Quality Control/ Quality Assurance (QC/QA); Quality Control for Performance (QCP); Pay for Performance (PFP)		

NOTE 1: THE UNIT WEIGHT USED TO CALCULATE ALL HMA SURFACE AND BINDER MIXTURE QUANTITIES IS 112 LB/SQ YD/IN EXCEPT FOR POLYMERIZED HOT-MIX ASPHALT BINDER COURSE, IL-4.75, N50 WHICH A UNIT WEIGHT OF 110 LB/SQ YD/IN IS USED.

NOTE 2: THE "AC TYPE" FOR POLYMERIZED HMA MIXES SHALL BE "SBS/SBR PG 76-22" AND FOR NON-POLYMERIZED HMA THE "AC TYPE" SHALL BE "PG 64 -22" UNLESS MODIFIED BY DISTRICT ONE SPECIAL PROVISIONS.

FOR USE OF RECYCLED MATERIALS SEE DISTRICT ONE SPECIAL PROVISION.
QUALITY MANAGEMENT PROGRAM (QMP) IDENTIFIES THE PARTICULAR QUALITY CONTROL SPECIFICATION THAT APPLIES TO THE HMA MIXTURE.

NOTE 3: THE LONGITUDINAL JOINT SEALANT SHALL BE PLACED UNDER THE SURFACE LIFT.

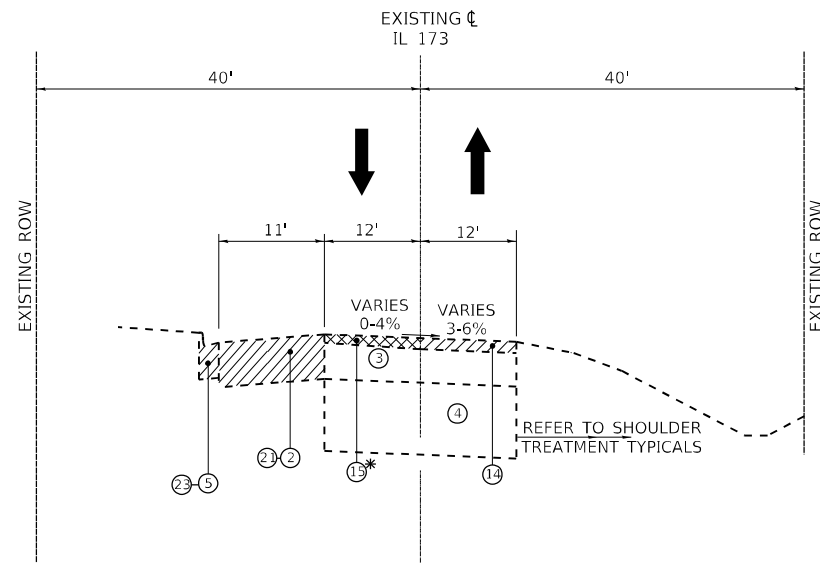

EXISTING TYPICAL SECTION
ILLINOIS ROUTE 173

STA. 109+50 TO STA 110+25
(LOOKING EAST)
SUPERELEVATED SECTION

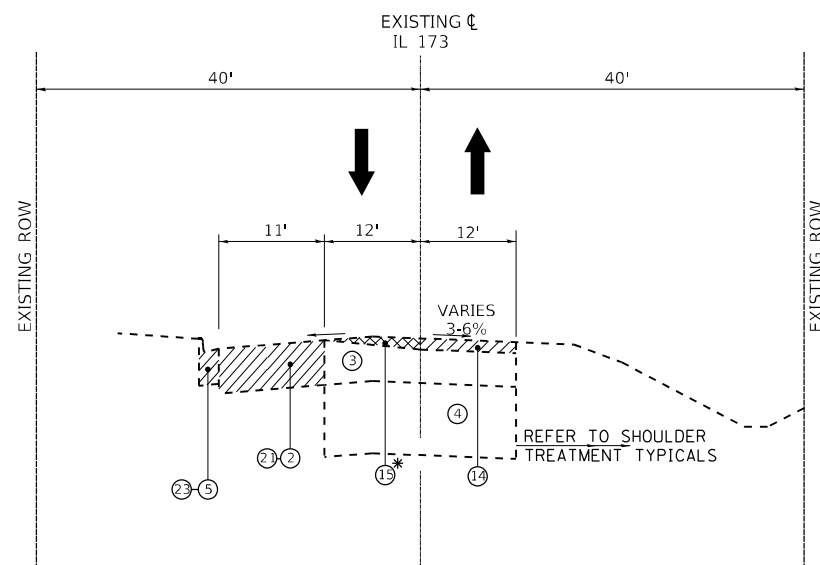

EXISTING TYPICAL SECTION
ILLINOIS ROUTE 173

STA. 110+25 TO STA 113+65
(LOOKING EAST)
CROWN SECTION

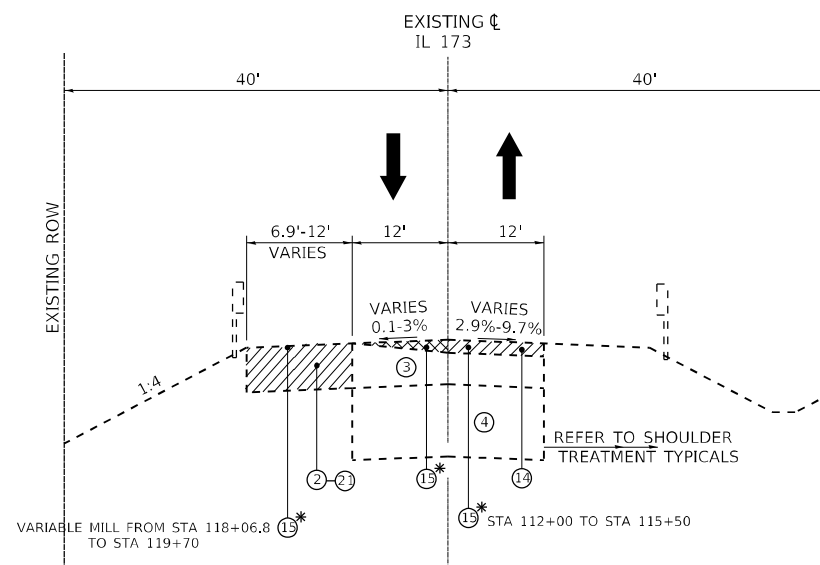

EXISTING TYPICAL SECTION
ILLINOIS ROUTE 173

STA. 113+65 TO STA 119+70
(LOOKING EAST)
CROWN SECTION

LEGEND:

- ① EXISTING AGGREGATE SHOULDER
- ② EXISTING HOT-MIX ASPHALT SHOULDER, 8"
- ③ EXISTING HOT-MIX ASPHALT OVERLAY, 8"
- ④ EXISTING PCC PAVEMENT, 7.5"
- ⑤ EXISTING CURB AND GUTTER
- ⑥ EXISTING HMA PAVEMENT, 4 1/4"
- ⑦ PROPOSED POLYMERIZED HMA SURFACE COURSE, SMA, 9.5, MIX "F", N 80, 1 3/4"
- ⑧ PROPOSED HMA SURFACE COURSE, IL-9.5, MIX "D", N 70, 1 3/4"
- ⑨ PROPOSED HMA BASE COURSE OR BASE COURSE WIDENING, 7 3/4"
- ⑨A PROPOSED HMA BASE COURSE OR BASE COURSE WIDENING, 7 1/2"
- ⑩ PROPOSED AGGREGATE SUBGRADE IMPROVEMENT, 12"
- ⑪ PROPOSED POLYMERIZED HMA BINDER COURSE, IL-4.75, N50, 3/4"
- ⑫ PROPOSED COMBINATION CURB AND GUTTER, TYPE B 6.24
- ⑬ PROPOSED COMBINATION CURB AND GUTTER, TYPE B 6.12
- ⑭ PROPOSED HOT-MIX ASPHALT SURFACE REMOVAL, 2 1/2"
- *⑮ PROPOSED HOT-MIX ASPHALT SURFACE REMOVAL, VARIABLE DEPTH
- ⑯ PROPOSED AGGREGATE SHOULDER REMOVAL, TO BE PAID FOR AS "REMOVAL AND DISPOSAL OF UNSUITABLE MATERIAL"
- ⑰ PROPOSED GEOTECHNICAL FABRIC FOR GROUND STABILIZATION
- ⑱ PROPOSED HMA BINDER COURSE, IL-19.0, N90, 5 1/2"
- ⑱A PROPOSED HMA BINDER COURSE, IL-19.0, N90, VARIABLE DEPTH
- ⑲ PROPOSED HMA BINDER COURSE, IL-19.0, N70, VARIABLE DEPTH
- ⑳ PROPOSED PIPE UNDERDRAINS, TYPE 2, 4"
- ㉑ PROPOSED PAVED SHOULDER REMOVAL
- ㉒ PROPOSED AGGREGATE SHOULDER, TYPE B 10"
- ㉓ PROPOSED CURB AND GUTTER REMOVAL

*REFER TO MILLING TABLE

- VARIABLE DEPTH MILLING
- CONSTANT DEPTH MILLING/
OR AGGREGATE SHOULDER REMOVAL

FILE NAME =	USER NAME = kalorm	DESIGNED -	REVISED - RK - 3/15/2021
p:\planning\dot.illinois.gov\PIWIDOT\Documents\IDOT Offices\District 1\Projects\PI171909\Design\PI171909-sht-typical.dgn		CHECKED -	REVISED -
		DATE -	REVISED -

**STATE OF ILLINOIS
DEPARTMENT OF TRANSPORTATION**

IL 173 AT NORTH LAKE AVENUE EXISTING TYPICAL SECTIONS			
SCALE:	SHEET NO.	OF SHEETS	STA. TO STA.

F.A.P. RTE.	SECTION	COUNTY	TOTAL SHEETS	SHEET NO.
303	(134&134XIN	LAKE	129	13
CONTRACT NO. 60V39				
ILLINOIS FED. AID PROJECT				

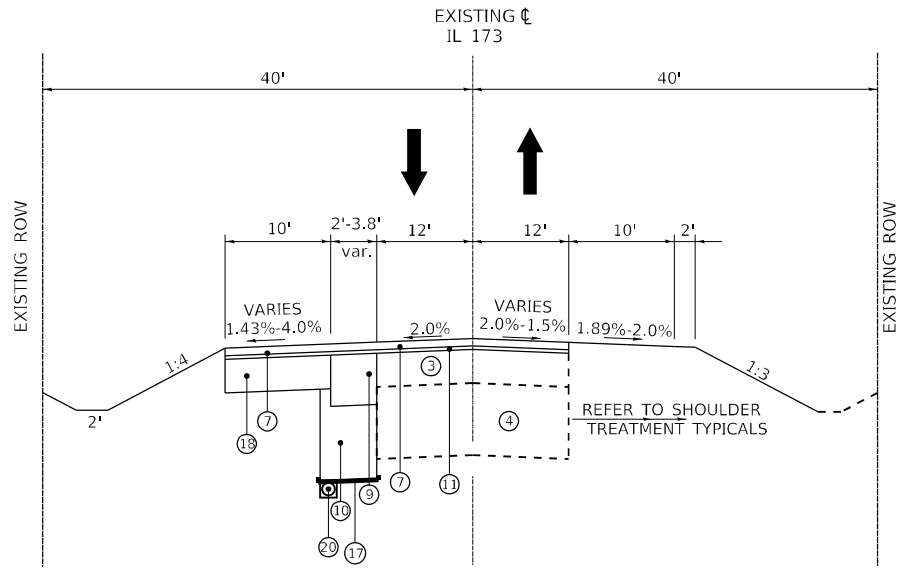

**PROPOSED TYPICAL SECTION
ILLINOIS ROUTE 173**
STA. 105+07.7 TO STA 106+07
(LOOKING EAST)
CROWN SECTION

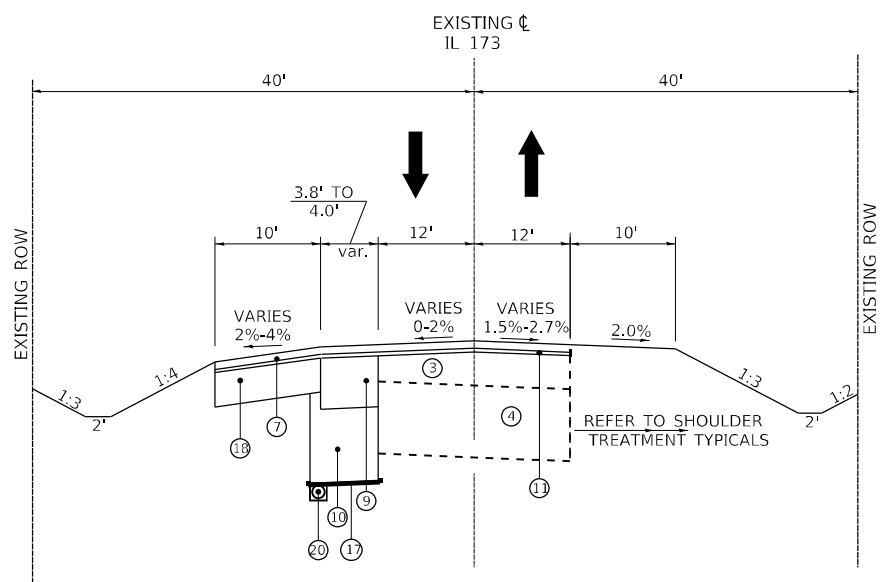

**PROPOSED TYPICAL SECTION
ILLINOIS ROUTE 173**
STA. 106+07 TO STA 106+50
(LOOKING EAST)

LEGEND:

- ① EXISTING AGGREGATE SHOULDER
- ② EXISTING HOT-MIX ASPHALT SHOULDER, 8"
- ③ EXISTING HOT-MIX ASPHALT OVERLAY, 8"
- ④ EXISTING PCC PAVEMENT, 7.5"
- ⑤ EXISTING CURB AND GUTTER
- ⑥ EXISTING HMA PAVEMENT, 4 1/4"
- ⑦ PROPOSED POLYMERIZED HMA SURFACE COURSE, SMA, 9.5, MIX "F", N 80, 1 3/4"
- ⑧ PROPOSED HMA SURFACE COURSE, IL-9.5, MIX "D", N 70, 1 3/4"
- ⑨ PROPOSED HMA BASE COURSE OR BASE COURSE WIDENING, 7 3/4"
- ⑨A PROPOSED HMA BASE COURSE OR BASE COURSE WIDENING, 7 1/2"
- ⑩ PROPOSED AGGREGATE SUBGRADE IMPROVEMENT, 12"
- ⑪ PROPOSED POLYMERIZED HMA BINDER COURSE, IL-4.75, N50, 3/4"
- ⑫ PROPOSED COMBINATION CURB AND GUTTER, TYPE B 6.24
- ⑬ PROPOSED COMBINATION CURB AND GUTTER, TYPE B 6.12
- *⑮ PROPOSED HOT-MIX ASPHALT SURFACE REMOVAL, VARIABLE DEPTH
- ⑯ PROPOSED AGGREGATE SHOULDER REMOVAL, TO BE PAID FOR AS "REMOVAL AND DISPOSAL OF UNSUITABLE MATERIAL"
- ⑰ PROPOSED GEOTECHNICAL FABRIC FOR GROUND STABILIZATION
- ⑱ PROPOSED HMA BINDER COURSE, IL-19.0, N90, 5 1/2"
- ⑱A PROPOSED HMA BINDER COURSE, IL-19.0, N90, VARIABLE DEPTH
- ⑲ PROPOSED HMA BINDER COURSE, IL-19.0, N70, VARIABLE DEPTH
- ⑳ PROPOSED PIPE UNDERDRAINS, TYPE 2, 4"
- ㉑ PROPOSED PAVED SHOULDER REMOVAL
- ㉒ PROPOSED AGGREGATE SHOULDER, TYPE B 10"
- ㉓ PROPOSED CURB AND GUTTER REMOVAL

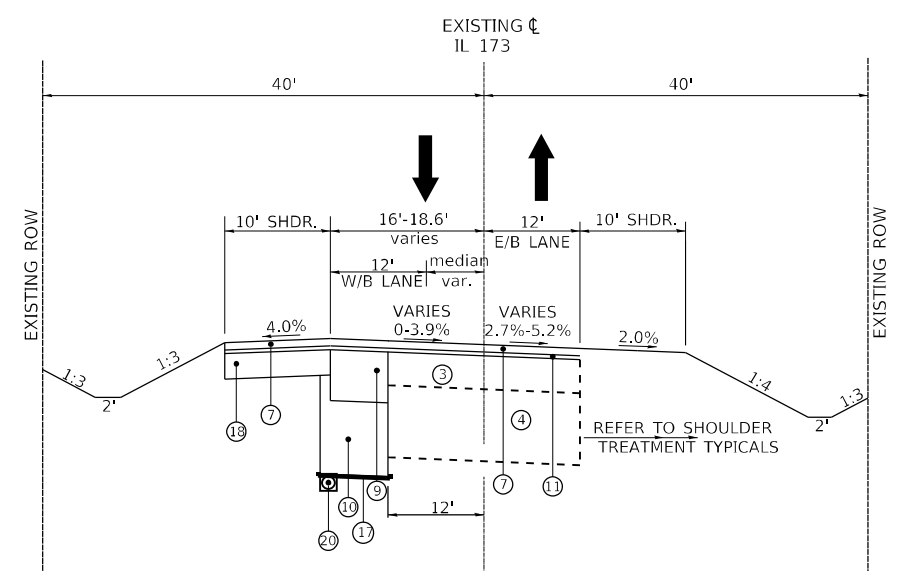

**PROPOSED TYPICAL SECTION
ILLINOIS ROUTE 173**
STA. 106+50 TO STA 107+38.7
(LOOKING EAST)

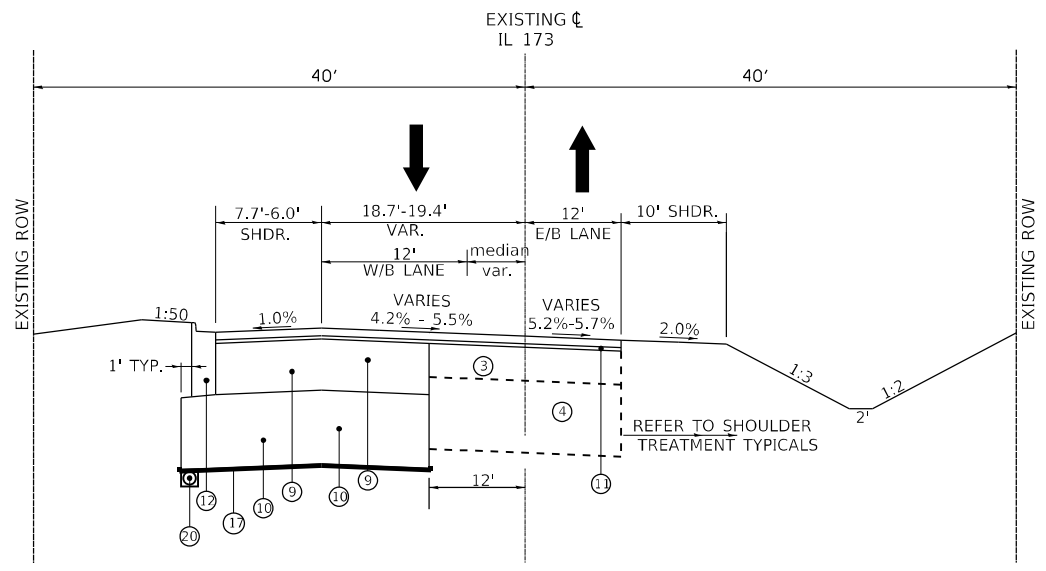

**PROPOSED TYPICAL SECTION
ILLINOIS ROUTE 173**
STA. 107+38.7 TO STA 107+70.5
(LOOKING EAST)
SUPERELEVATED SECTION

NOTE:
EXTEND PROPOSED AGGREGATE SUBGRADE IMPROVEMENT 12",
12" BEYOND CURB & GUTTER, AND 12" BEYOND PROPOSED
WIDENING.

FILE NAME =	USER NAME = kalorm	DESIGNED -	REVISED - RK - 3/15/2021	STATE OF ILLINOIS DEPARTMENT OF TRANSPORTATION	IL 173 AT NORTH LAKE AVENUE PROPOSED TYPICAL SECTIONS			F.A.P. RTE.	SECTION	COUNTY	TOTAL SHEETS	SHEET NO.
pw:\planning\dot.illinois.gov\PI171909-Design\PI171909-sht-typical.dgn		CHECKED -	REVISED -					303	(134&134XIN	LAKE	129	14
PLOT SCALE = 100.0000' / in.		DATE -	REVISED -					CONTRACT NO. 60V39				
PLOT DATE = 3/15/2021								ILLINOIS FED. AID PROJECT				
				SCALE:	SHEET NO.	OF SHEETS	STA.	TO STA.				

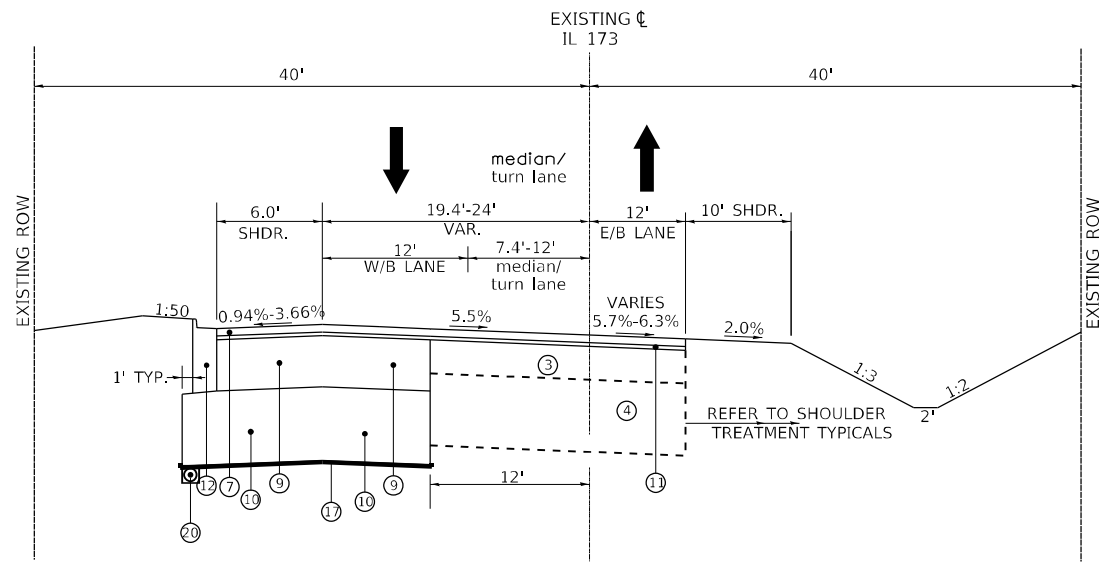

PROPOSED TYPICAL SECTION
ILLINOIS ROUTE 173
STA 107+70.5 TO STA 110+25
(LOOKING EAST)
SUPERELEVATED SECTION

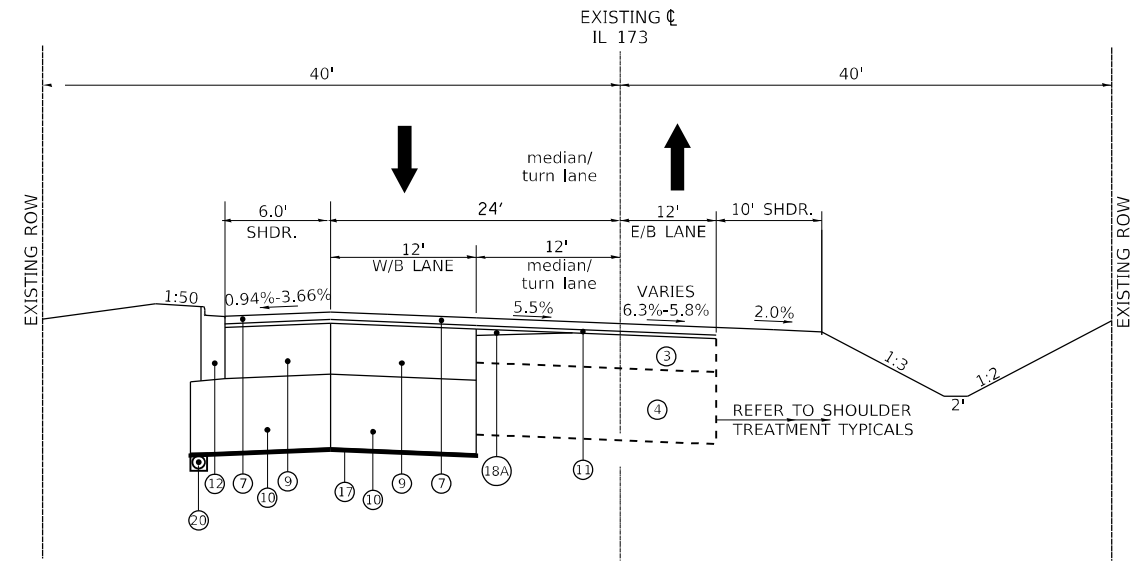

PROPOSED TYPICAL SECTION
ILLINOIS ROUTE 173
STA 110+25 TO STA 111+50
(LOOKING EAST)
SUPERELEVATED SECTION

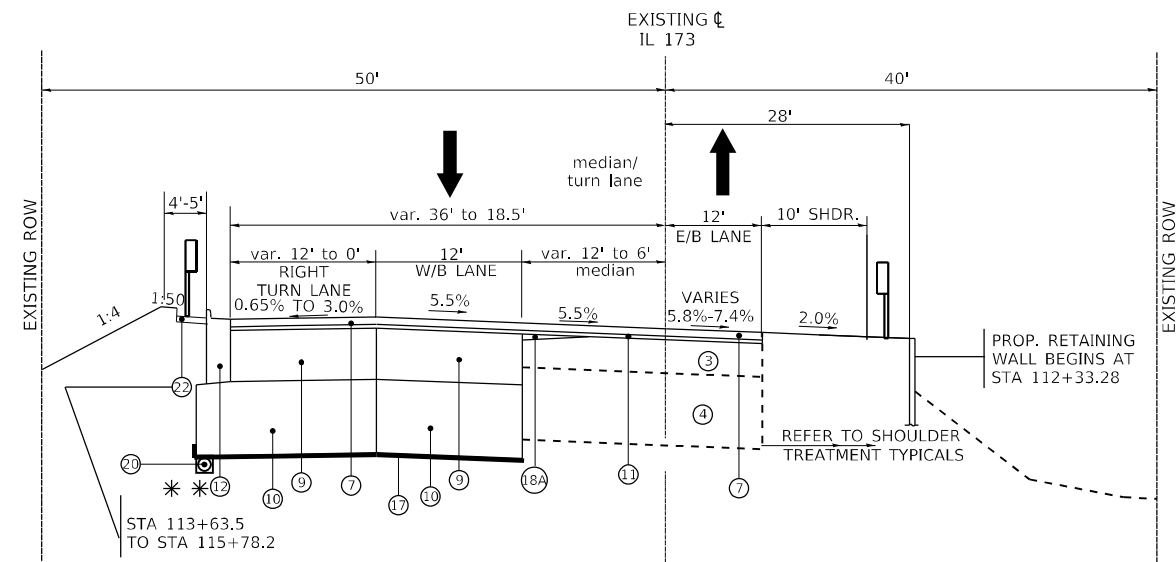

* * B6.24 CURB TRANSITION
AT STA. 115+12.0

PROPOSED TYPICAL SECTION
ILLINOIS ROUTE 173
STA 111+50 TO STA. 115+92.4
(LOOKING EAST)
SUPERELEVATED SECTION

LEGEND:

- ① EXISTING AGGREGATE SHOULDER
- ② EXISTING HOT-MIX ASPHALT SHOULDER, 8"
- ③ EXISTING HOT-MIX ASPHALT OVERLAY, 8"
- ④ EXISTING PCC PAVEMENT, 7.5"
- ⑤ EXISTING CURB AND GUTTER
- ⑥ EXISTING HMA PAVEMENT, 4 1/4"
- ⑦ PROPOSED POLYMERIZED HMA SURFACE COURSE, SMA, 9.5, MIX "F", N 80, 1 3/4"
- ⑧ PROPOSED HMA SURFACE COURSE, IL-9.5, MIX "D", N 70, 1 3/4"
- ⑨ PROPOSED HMA BASE COURSE OR BASE COURSE WIDENING, 7 3/4"
- ⑨A PROPOSED HMA BASE COURSE OR BASE COURSE WIDENING, 7 1/2"
- ⑩ PROPOSED AGGREGATE SUBGRADE IMPROVEMENT, 12"
- ⑪ PROPOSED POLYMERIZED HMA BINDER COURSE, IL-4.75, N50, 3/4"
- ⑫ PROPOSED COMBINATION CURB AND GUTTER, TYPE B 6.24
- ⑬ PROPOSED COMBINATION CURB AND GUTTER, TYPE B 6.12
- ⑭ PROPOSED HOT-MIX ASPHALT SURFACE REMOVAL, 2 1/2"
- * ⑮ PROPOSED HOT-MIX ASPHALT SURFACE REMOVAL, VARIABLE DEPTH
- ⑯ PROPOSED AGGREGATE SHOULDER REMOVAL TO BE PAID FOR AS "REMOVAL AND DISPOSAL OF UNSUITABLE MATERIAL"
- ⑰ PROPOSED GEOTECHNICAL FABRIC FOR GROUND STABILIZATION
- ⑱ PROPOSED HMA BINDER COURSE, IL-19.0, N90, 5 1/2"
- ⑱A PROPOSED HMA BINDER COURSE, IL-19.0, N90, VARIABLE DEPTH
- ⑲ PROPOSED HMA BINDER COURSE, IL-19.0, N70, VARIABLE DEPTH
- ⑳ PROPOSED PIPE UNDERDRAINS, TYPE 2, 4"
- ㉑ PROPOSED PAVED SHOULDER REMOVAL
- ㉒ PROPOSED AGGREGATE SHOULDER, TYPE B 10"
- ㉓ PROPOSED CURB AND GUTTER REMOVAL

NOTE:
EXTEND PROPOSED AGGREGATE SUBGRADE IMPROVEMENT 12",
12" BEYOND CURB & GUTTER, AND 12" BEYOND PROPOSED
WIDENING.

FILE NAME =	USER NAME = kalorm	DESIGNED -	REVISED - RK - 3/15/2021
pw:\planroom.dot.illinois.gov\PWIDOT\Documents\IDOT Offices\District 1\Projects\P171909\Drawings\Design\P171909-sht-typical.dgn		CHECKED -	REVISED -
		DATE -	REVISED -

STATE OF ILLINOIS
DEPARTMENT OF TRANSPORTATION

IL 173 AT NORTH LAKE AVENUE PROPOSED TYPICAL SECTIONS		F.A.P. RTE. 303	SECTION (134&134XIN)	COUNTY LAKE	TOTAL SHEETS 129	SHEET NO. 15
SCALE:	SHEET NO. OF SHEETS	STA. TO STA.	CONTRACT NO. 60V39			
ILLINOIS FED. AID PROJECT						

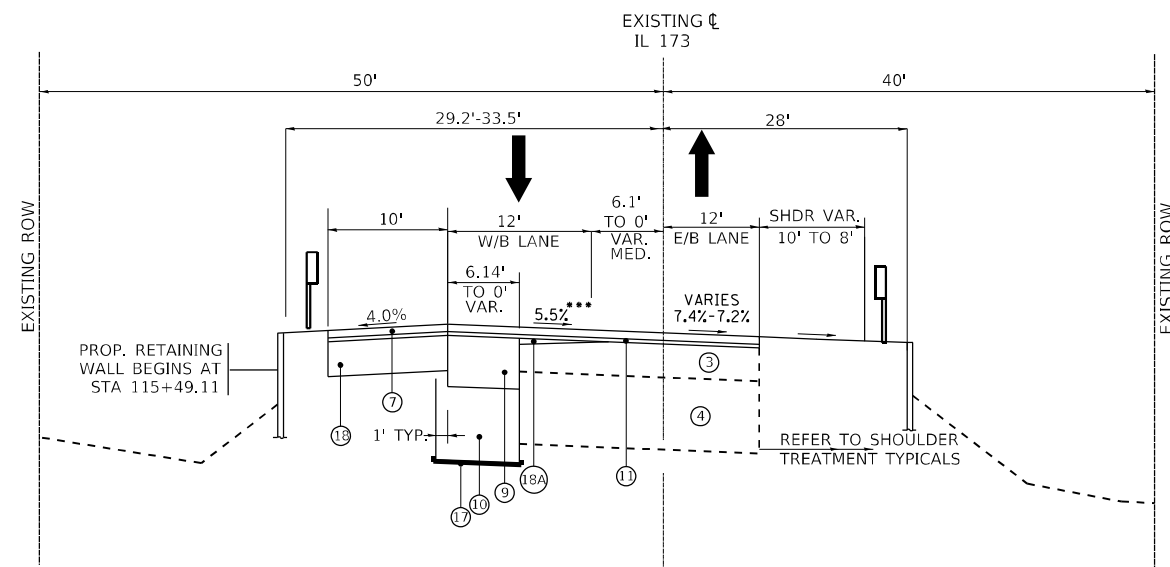

**PROPOSED TYPICAL SECTION
ILLINOIS ROUTE 173**

STA. 115+92.4 TO STA. 118+06.8
(LOOKING EAST)
SUPERELEVATED SECTION

*** CROSS SLOPE AT STA. 118+00 IS 5.5%
SUPERELEVATION REDUCES TO 0% AT STA. 119+15.4
STA. 119+15.4 TO STA. 119+70 CROWN CROSS SECTION RESUMES
WIDENING ENDS AT STA. 118+06.8

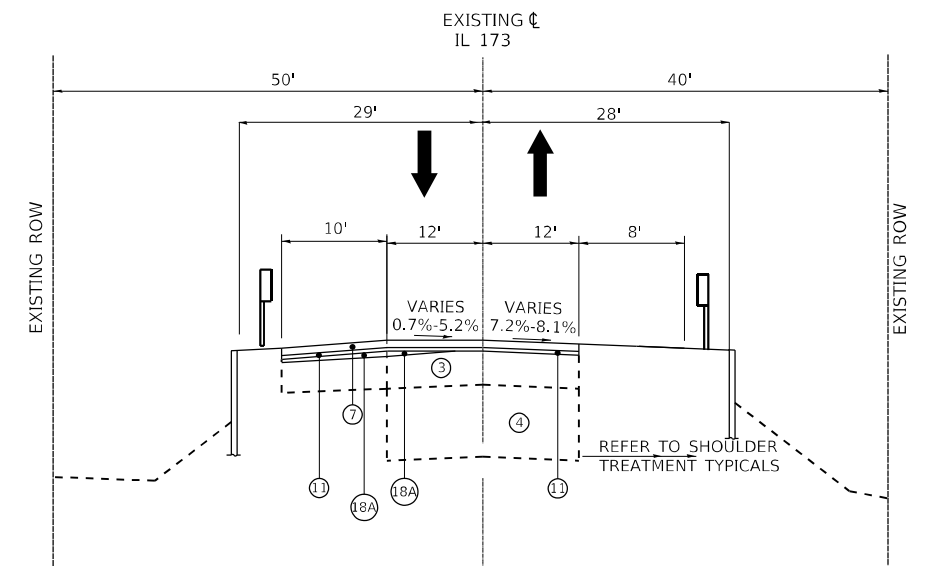

**PROPOSED TYPICAL SECTION
ILLINOIS ROUTE 173**

STA. 118+06.8 TO STA. 119+00
(LOOKING EAST)
CROWN SECTION

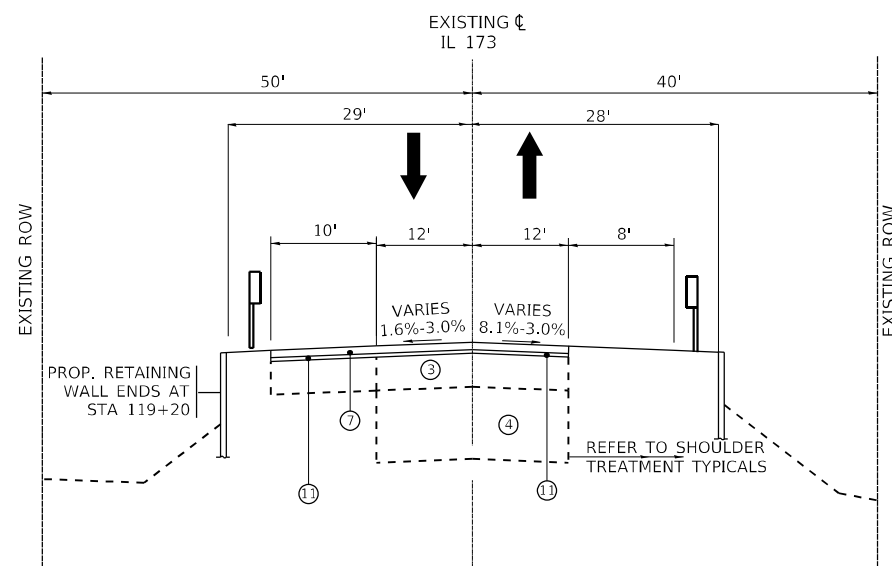

**PROPOSED TYPICAL SECTION
ILLINOIS ROUTE 173**

STA. 119+00 TO STA. 119+70
(LOOKING EAST)
CROWN SECTION

NOTE:
EXTEND PROPOSED AGGREGATE SUBGRADE IMPROVEMENT 12",
12" BEYOND CURB & GUTTER, AND 12" BEYOND PROPOSED
WIDENING.

LEGEND:

- ① EXISTING AGGREGATE SHOULDER
- ② EXISTING HOT-MIX ASPHALT SHOULDER, 8"
- ③ EXISTING HOT-MIX ASPHALT OVERLAY, 8"
- ④ EXISTING PCC PAVEMENT, 7.5"
- ⑤ EXISTING CURB AND GUTTER
- ⑥ EXISTING HMA PAVEMENT, 4 1/4"
- ⑦ PROPOSED POLYMERIZED HMA SURFACE COURSE, SMA, 9.5, MIX "F", N 80, 1 3/4"
- ⑧ PROPOSED HMA SURFACE COURSE, IL-9.5, MIX "D", N 70, 1 3/4"
- ⑨ PROPOSED HMA BASE COURSE OR BASE COURSE WIDENING, 7 3/4"
- ⑨A PROPOSED HMA BASE COURSE OR BASE COURSE WIDENING, 7 1/2"
- ⑩ PROPOSED AGGREGATE SUBGRADE IMPROVEMENT, 12"
- ⑪ PROPOSED POLYMERIZED HMA BINDER COURSE, IL-4.75, N50, 3/4"
- ⑫ PROPOSED COMBINATION CURB AND GUTTER, TYPE B 6.24
- ⑬ PROPOSED COMBINATION CURB AND GUTTER, TYPE B 6.12
- ⑭ PROPOSED HOT-MIX ASPHALT SURFACE REMOVAL, 2 1/4"
- * ⑮ PROPOSED HOT-MIX ASPHALT SURFACE REMOVAL, VARIABLE DEPTH
- ⑯ PROPOSED AGGREGATE SHOULDER REMOVAL, TO BE PAID FOR AS "REMOVAL AND DISPOSAL OF UNSUITABLE MATERIAL"
- ⑰ PROPOSED GEOTECHNICAL FABRIC FOR GROUND STABILIZATION
- ⑱ PROPOSED HMA BINDER COURSE, IL-19.0, N90, 5 1/2"
- ⑱A PROPOSED HMA BINDER COURSE, IL-19.0, N90, VARIABLE DEPTH
- ⑲ PROPOSED HMA BINDER COURSE, IL-19.0, N70, VARIABLE DEPTH
- ⑳ PROPOSED PIPE UNDERDRAINS, TYPE 2, 4"
- ㉑ PROPOSED PAVED SHOULDER REMOVAL
- ㉒ PROPOSED AGGREGATE SHOULDER, TYPE B 10"
- ㉓ PROPOSED CURB AND GUTTER REMOVAL

FILE NAME =	USER NAME = kalorm	DESIGNED -	REVISED - RK - 3/15/2021
pw:\plnroom.dot\illinois.gov\PIDOT\Documents\IDOT Offices\District 1\Projects\P171909\Drawings\Design\P171909-sht-typical.dgn		CHECKED -	REVISED -
		DATE -	REVISED -

**STATE OF ILLINOIS
DEPARTMENT OF TRANSPORTATION**

**IL 173 AT NORTH LAKE AVENUE
PROPOSED TYPICAL SECTIONS**

SCALE: SHEET NO. OF SHEETS STA. TO STA.

F.A.P. RTE.	SECTION	COUNTY	TOTAL SHEETS	SHEET NO.
303	(134&134XIN	LAKE	129	16
CONTRACT NO. 60V39				
ILLINOIS FED. AID PROJECT				

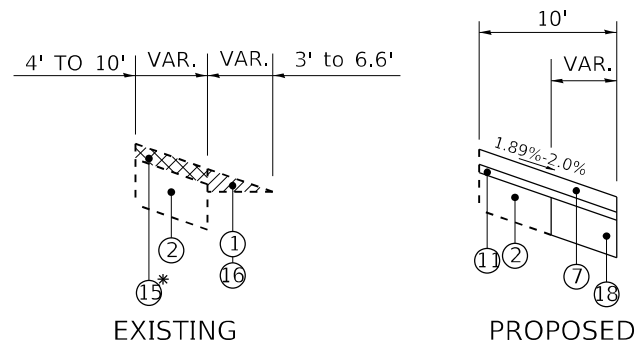

**SHOULDER TREATMENT
ILLINOIS ROUTE 173**
STA. 105+07.7 TO STA. 108+00
LOOKING EAST
SHOULDER RESURFACING AND WIDENING

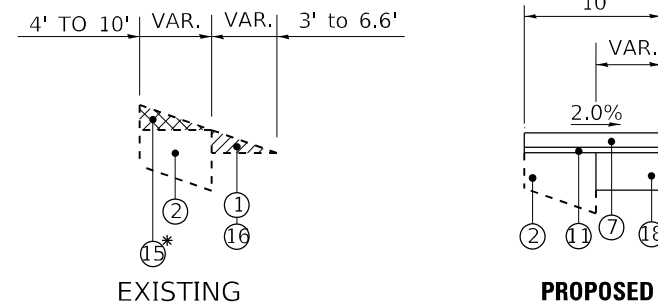

**SHOULDER TREATMENT
ILLINOIS ROUTE 173**
STA. 108+00 TO STA. 111+50
LOOKING EAST
SHOULDER RESURFACING AND WIDENING

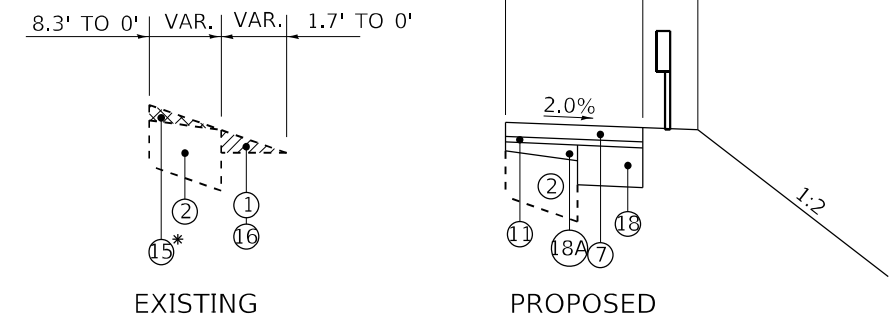

**SHOULDER TREATMENT
ILLINOIS ROUTE 173**
STA. 111+50 TO STA. 112+25
LOOKING EAST
SHOULDER BUILD UP AND WIDENING

•REFER TO MILLING TABLE

- VARIABLE DEPTH MILLING
- CONSTANT DEPTH MILLING/
OR AGGREGATE SHOULDER REMOVAL

LEGEND:

- ① EXISTING AGGREGATE SHOULDER
- ② EXISTING HOT-MIX ASPHALT SHOULDER, 8"
- ③ EXISTING HOT-MIX ASPHALT OVERLAY, 8"
- ④ EXISTING PCC PAVEMENT, 7.5"
- ⑤ EXISTING CURB AND GUTTER
- ⑥ EXISTING HMA PAVEMENT, 4 1/4"
- ⑦ PROPOSED POLYMERIZED HMA SURFACE COURSE, SMA, 9.5, MIX "F", N 80, 1 3/4"
- ⑧ PROPOSED HMA SURFACE COURSE, IL-9.5, MIX "D", N 70, 1 3/4"
- ⑨ PROPOSED HMA BASE COURSE OR BASE COURSE WIDENING, 7 3/4"
- ⑨A PROPOSED HMA BASE COURSE OR BASE COURSE WIDENING, 7 1/2"
- ⑩ PROPOSED AGGREGATE SUBGRADE IMPROVEMENT, 12"
- ⑪ PROPOSED POLYMERIZED HMA BINDER COURSE, IL-4.75, N50, 3/4"
- ⑫ PROPOSED COMBINATION CURB AND GUTTER, TYPE B 6.24
- ⑬ PROPOSED COMBINATION CURB AND GUTTER, TYPE B 6.12
- ⑭ PROPOSED HOT-MIX ASPHALT SURFACE REMOVAL, 2 1/2"
- *⑮ PROPOSED HOT-MIX ASPHALT SURFACE REMOVAL, VARIABLE DEPTH
- ⑯ PROPOSED AGGREGATE SHOULDER REMOVAL, TO BE PAID FOR AS "REMOVAL AND DISPOSAL OF UNSUITABLE MATERIAL"
- ⑰ PROPOSED GEOTECHNICAL FABRIC FOR GROUND STABILIZATION
- ⑱ PROPOSED HMA BINDER COURSE, IL-19.0, N90, 5 1/2"
- ⑱A PROPOSED HMA BINDER COURSE, IL-19.0, N90, VARIABLE DEPTH
- ⑲ PROPOSED HMA BINDER COURSE, IL-19.0, N70, VARIABLE DEPTH
- ⑳ PROPOSED PIPE UNDERDRAINS, TYPE 2, 4"
- ㉑ PROPOSED PAVED SHOULDER REMOVAL
- ㉒ PROPOSED AGGREGATE SHOULDER, TYPE B 10"
- ㉓ PROPOSED CURB AND GUTTER REMOVAL

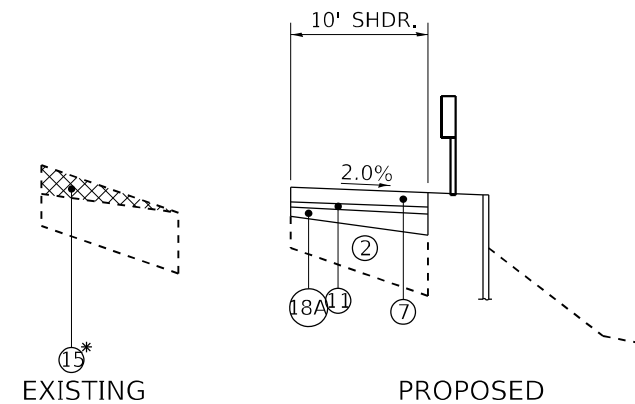

**SHOULDER TREATMENT
ILLINOIS ROUTE 173**
STA. 112+25 TO STA. 115+15.5
LOOKING EAST
(SHOULDER BUILD UP)

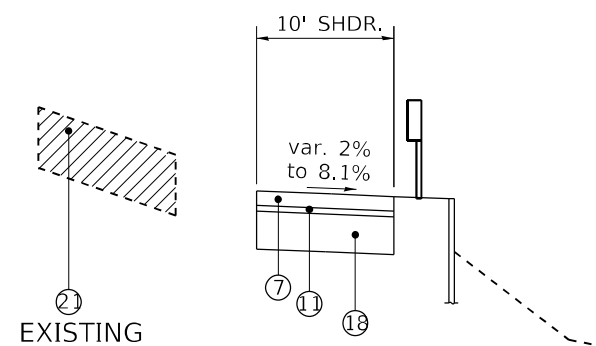

**PROPOSED SHOULDER TREATMENT
ILLINOIS ROUTE 173**
STA. 115+15.5 TO STA. 117+50
LOOKING EAST
(NEW SHOULDER)

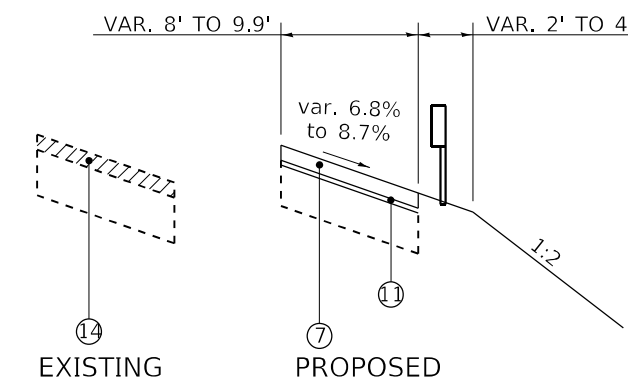

**SHOULDER TREATMENT
ILLINOIS ROUTE 173**
STA. 117+50 TO STA. 119+70
LOOKING EAST
SHOULDER RESURFACING

FILE NAME =	USER NAME = kalorm	DESIGNED -	REVISED - RK - 3/15/2021	STATE OF ILLINOIS DEPARTMENT OF TRANSPORTATION	IL 173 AT NORTH LAKE AVENUE RIGHT SHOULDER TYPICAL SECTIONS			F.A.P. RTE.	SECTION	COUNTY	TOTAL SHEETS	SHEET NO.
p:\plnroom\dot.illinois.gov\PIDOT\Documents\IDOT Offices\District 1\Projects\P171909\Drawings\Design\P171909-sht-typical.dgn	PLOT SCALE = 100.0000' / in.	CHECKED -	REVISED -					303	(134&134XIN)	LAKE	129	17
PLOT DATE = 3/15/2021	DATE -	REVISED -	REVISED -		CONTRACT NO. 60V39			ILLINOIS FED. AID PROJECT				
					SCALE:	SHEET NO.	OF SHEETS	STA.	TO STA.			

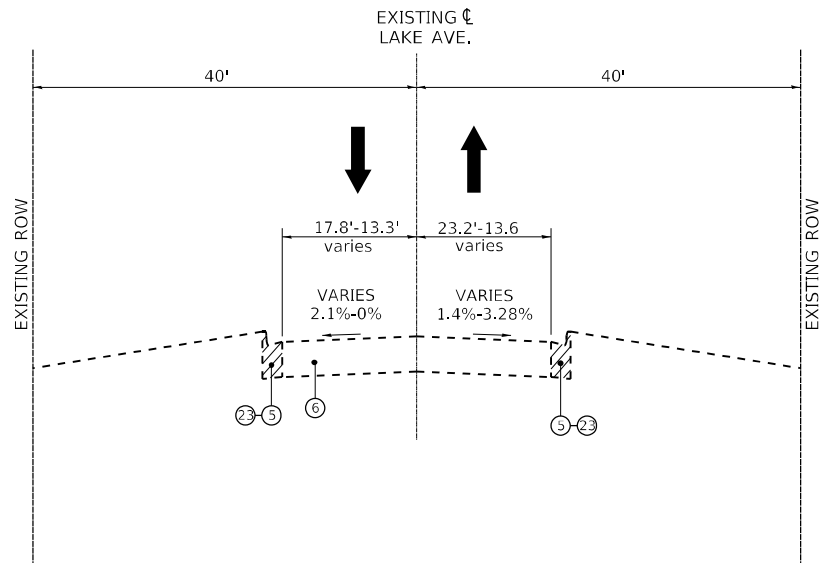

EXISTING TYPICAL SECTION
LAKE AVENUE

STA. 200+71 TO STA 201+00
(LOOKING NORTH)
CROWN SECTION

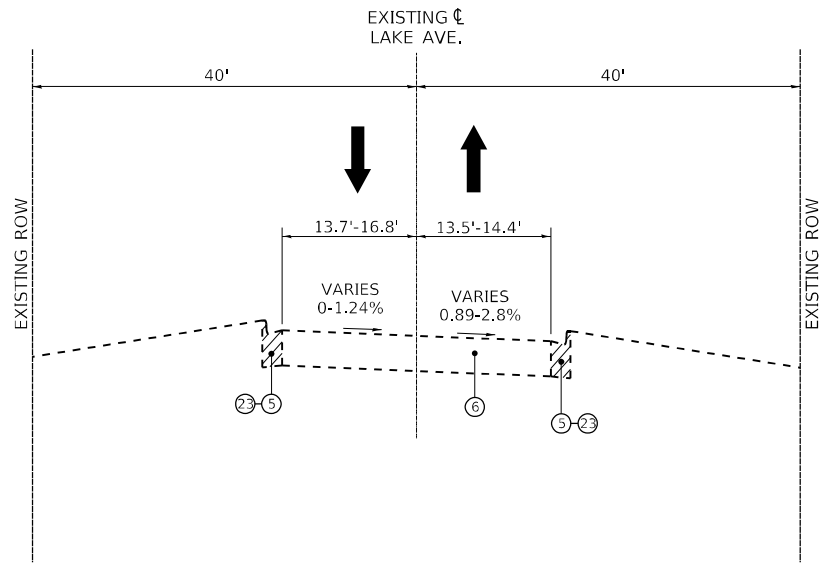

EXISTING TYPICAL SECTION
LAKE AVENUE

STA. 201+00 TO STA 201+89
(LOOKING NORTH)
SUPERELEVATED SECTION

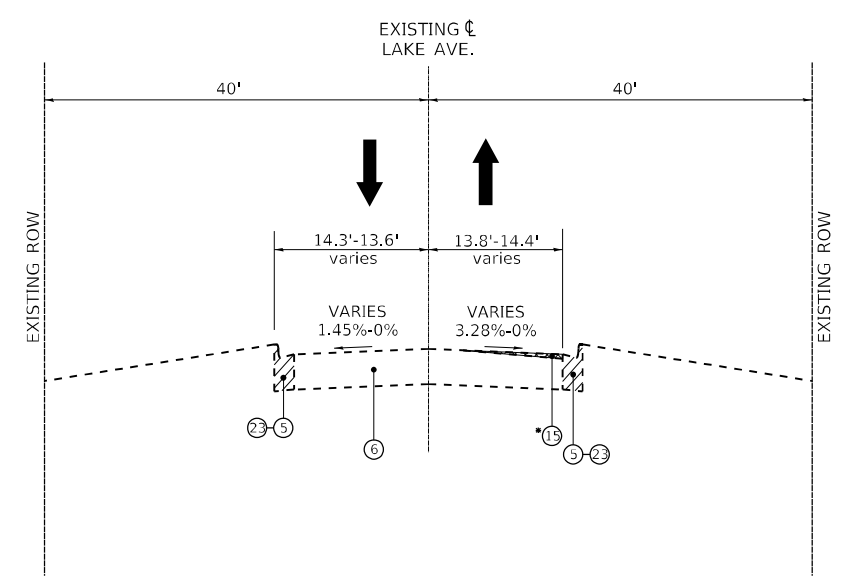

EXISTING TYPICAL SECTION
LAKE AVENUE

STA 201+89 TO STA 203+74
(LOOKING NORTH)

*REFER TO MILLING TABLE

- VARIABLE DEPTH MILLING
- CONSTANT DEPTH MILLING/
OR AGGREGATE SHOULDER REMOVAL

LEGEND:

- ① EXISTING AGGREGATE SHOULDER
- ② EXISTING HOT-MIX ASPHALT SHOULDER, 8"
- ③ EXISTING HOT-MIX ASPHALT OVERLAY, 8"
- ④ EXISTING PCC PAVEMENT, 7.5"
- ⑤ EXISTING CURB AND GUTTER
- ⑥ EXISTING HMA PAVEMENT, 4 1/4"
- ⑦ PROPOSED POLYMERIZED HMA SURFACE COURSE, SMA, 9.5, MIX "F", N 80, 1 3/4"
- ⑧ PROPOSED HMA SURFACE COURSE, IL-9.5, MIX "D", N 70, 1 3/4"
- ⑨ PROPOSED HMA BASE COURSE OR BASE COURSE WIDENING, 7 3/4"
- ⑨A PROPOSED HMA BASE COURSE OR BASE COURSE WIDENING, 7 1/2"
- ⑩ PROPOSED AGGREGATE SUBGRADE IMPROVEMENT, 12"
- ⑪ PROPOSED POLYMERIZED HMA BINDER COURSE, IL-4.75, N50, 3/4"
- ⑫ PROPOSED COMBINATION CURB AND GUTTER, TYPE B 6.24
- ⑬ PROPOSED COMBINATION CURB AND GUTTER, TYPE B 6.12
- ⑭ PROPOSED HOT-MIX ASPHALT SURFACE REMOVAL, 2 1/2"
- *⑮ PROPOSED HOT-MIX ASPHALT SURFACE REMOVAL, VARIABLE DEPTH
- ⑯ PROPOSED AGGREGATE SHOULDER REMOVAL, TO BE PAID FOR AS "REMOVAL AND DISPOSAL OF UNSUITABLE MATERIAL"
- ⑰ PROPOSED GEOTECHNICAL FABRIC FOR GROUND STABILIZATION
- ⑱ PROPOSED HMA BINDER COURSE, IL-19.0, N90, 5 1/2"
- ⑱A PROPOSED HMA BINDER COURSE, IL-19.0, N90, VARIABLE DEPTH
- ⑲ PROPOSED HMA BINDER COURSE, IL-19.0, N70, VARIABLE DEPTH
- ⑳ PROPOSED PIPE UNDERDRAINS, TYPE 2, 4"
- ㉑ PROPOSED PAVED SHOULDER REMOVAL
- ㉒ PROPOSED AGGREGATE SHOULDER, TYPE B 10"
- ㉓ PROPOSED CURB AND GUTTER REMOVAL

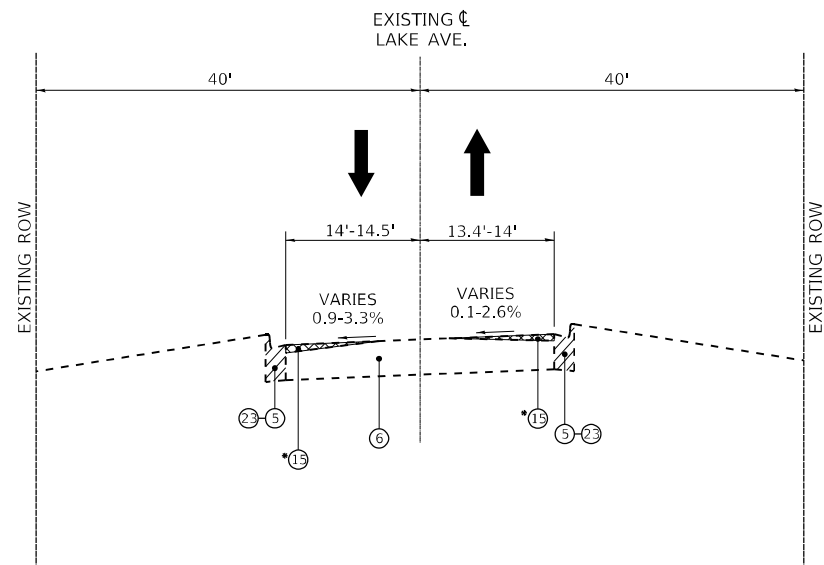

EXISTING TYPICAL SECTION
LAKE AVENUE

STA. 203+74 TO STA 204+86
(LOOKING NORTH)
SUPERELEVATED SECTION

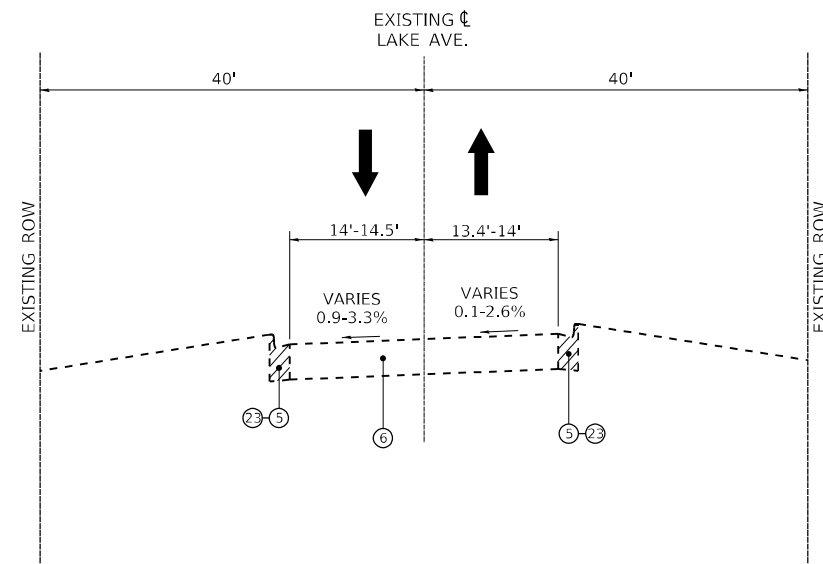

EXISTING TYPICAL SECTION
LAKE AVENUE

STA. 204+86 TO STA 205+00
(LOOKING NORTH)
SUPERELEVATED SECTION

FILE NAME =	USER NAME = kalorm	DESIGNED -	REVISED - RK - 3/15/2021
pw:\planroom.dot\illinois.gov\PIDOT\Documents\IDOT Offices\District 1\Projects\P171909\DRAWING\Design\P171909-sht-typical.dgn		CHECKED -	REVISED -
	PLOT SCALE = 100.0000' / in.	DATE -	REVISED -
	PLOT DATE = 3/15/2021		

**STATE OF ILLINOIS
DEPARTMENT OF TRANSPORTATION**

IL 173 AT NORTH LAKE AVENUE EXISTING TYPICAL SECTIONS			
SCALE:	SHEET NO.	OF SHEETS	STA. TO STA.

F.A.P. RTE.	SECTION	COUNTY	TOTAL SHEETS	SHEET NO.
303	(134&134XIN	LAKE	129	18
CONTRACT NO. 60V39				
ILLINOIS FED. AID PROJECT				

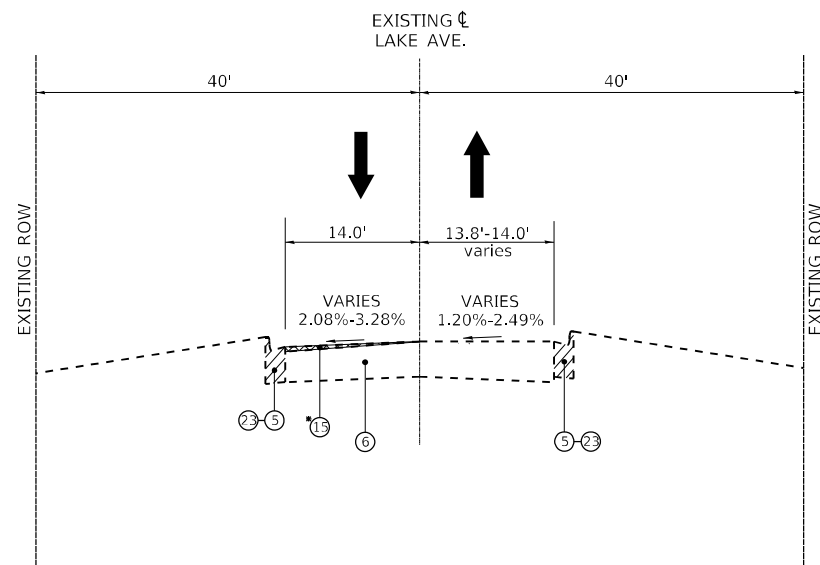

EXISTING TYPICAL SECTION
LAKE AVENUE
STA 205+00 TO STA 206+50
(LOOKING NORTH)
SUPERELEVATED SECTION

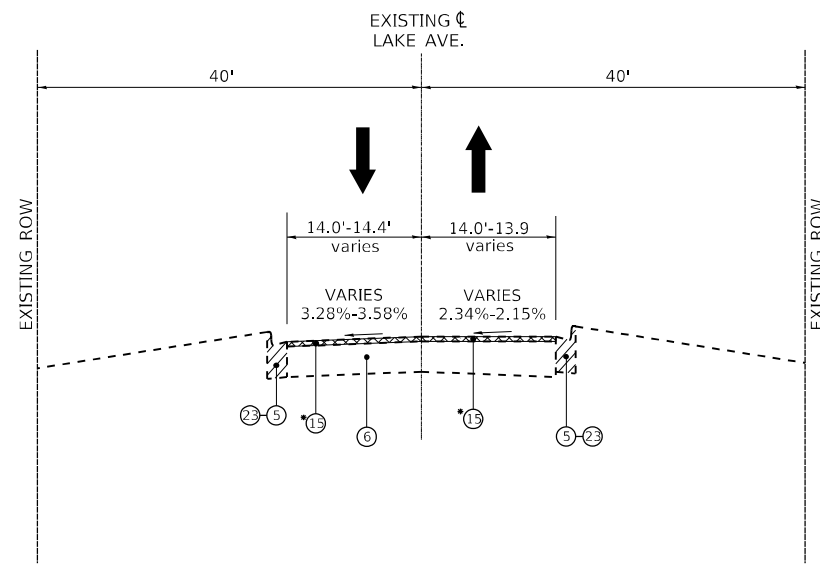

EXISTING TYPICAL SECTION
LAKE AVENUE
STA 206+50 TO STA 206+78
(LOOKING NORTH)
SUPERELEVATED SECTION

•REFER TO MILLING TABLE

- VARIABLE DEPTH MILLING
- CONSTANT DEPTH MILLING/
OR AGGREGATE SHOULDER REMOVAL

LEGEND:

- ① EXISTING AGGREGATE SHOULDER
- ② EXISTING HOT-MIX ASPHALT SHOULDER, 8"
- ③ EXISTING HOT-MIX ASPHALT OVERLAY, 8"
- ④ EXISTING PCC PAVEMENT, 7.5"
- ⑤ EXISTING CURB AND GUTTER
- ⑥ EXISTING HMA PAVEMENT, 4 1/4"
- ⑦ PROPOSED POLYMERIZED HMA SURFACE COURSE, SMA, 9.5, MIX "F", N 80, 1 3/4"
- ⑧ PROPOSED HMA SURFACE COURSE, IL-9.5, MIX "D", N 70, 1 3/4"
- ⑨ PROPOSED HMA BASE COURSE OR BASE COURSE WIDENING, 7 3/4"
- ⑨A PROPOSED HMA BASE COURSE OR BASE COURSE WIDENING, 7 1/2"
- ⑩ PROPOSED AGGREGATE SUBGRADE IMPROVEMENT, 12"
- ⑪ PROPOSED POLYMERIZED HMA BINDER COURSE, IL-4.75, N50, 3/4"
- ⑫ PROPOSED COMBINATION CURB AND GUTTER, TYPE B 6.24
- ⑬ PROPOSED COMBINATION CURB AND GUTTER, TYPE B 6.12
- ⑭ PROPOSED HOT-MIX ASPHALT SURFACE REMOVAL, 2 1/2"
- *⑮ PROPOSED HOT-MIX ASPHALT SURFACE REMOVAL, VARIABLE DEPTH
- ⑯ PROPOSED AGGREGATE SHOULDER REMOVAL, TO BE PAID FOR AS "REMOVAL AND DISPOSAL OF UNSUITABLE MATERIAL"
- ⑰ PROPOSED GEOTECHNICAL FABRIC FOR GROUND STABILIZATION
- ⑱ PROPOSED HMA BINDER COURSE, IL-19.0, N90, 5 1/2"
- ⑱A PROPOSED HMA BINDER COURSE, IL-19.0, N90, VARIABLE DEPTH
- ⑱B PROPOSED HMA BINDER COURSE, IL-19.0, N70, VARIABLE DEPTH
- ⑳ PROPOSED PIPE UNDERDRAINS, TYPE 2, 4"
- ㉑ PROPOSED PAVED SHOULDER REMOVAL
- ㉒ PROPOSED AGGREGATE SHOULDER, TYPE B 10"
- ㉓ PROPOSED CURB AND GUTTER REMOVAL

FILE NAME =	USER NAME = kalorm	DESIGNED -	REVISED - RK - 3/15/2021
p:\planning\dot\illinois.gov\PIDOT\Documents\IDOT Offices\District 1\Projects\P171909\DRAWING\Design\P171909-sht-typical.dgn		CHECKED -	REVISED -
	PLOT SCALE = 100.0000' / in.	DATE -	REVISED -
	PLOT DATE = 3/15/2021		

**STATE OF ILLINOIS
DEPARTMENT OF TRANSPORTATION**

**IL 173 AT NORTH LAKE AVENUE
EXISTING TYPICAL SECTIONS**

SCALE: SHEET NO. OF SHEETS STA. TO STA.

F.A.P. RTE.	SECTION	COUNTY	TOTAL SHEETS	SHEET NO.
303	(134&134XIN	LAKE	129	19
CONTRACT NO. 60V39			ILLINOIS FED. AID PROJECT	

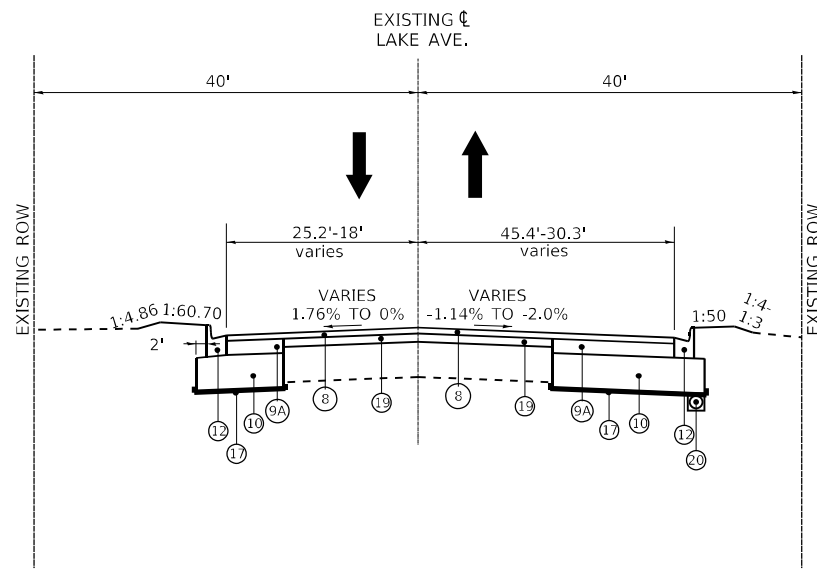

**PROPOSED TYPICAL SECTION
LAKE AVENUE**
STA. 200+71 TO STA 200+84
(LOOKING NORTH)
CROWN SECTION

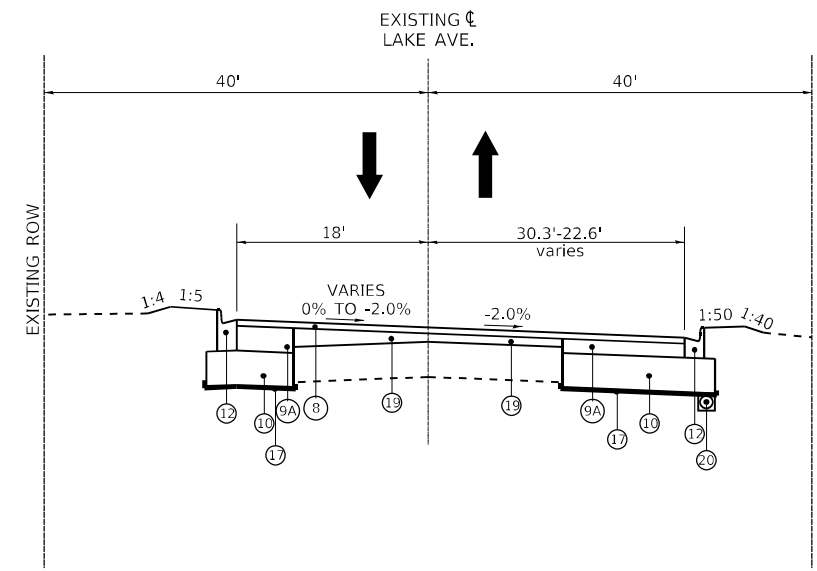

**PROPOSED TYPICAL SECTION
LAKE AVENUE**
STA 200+84 TO STA 201+23
(LOOKING NORTH)

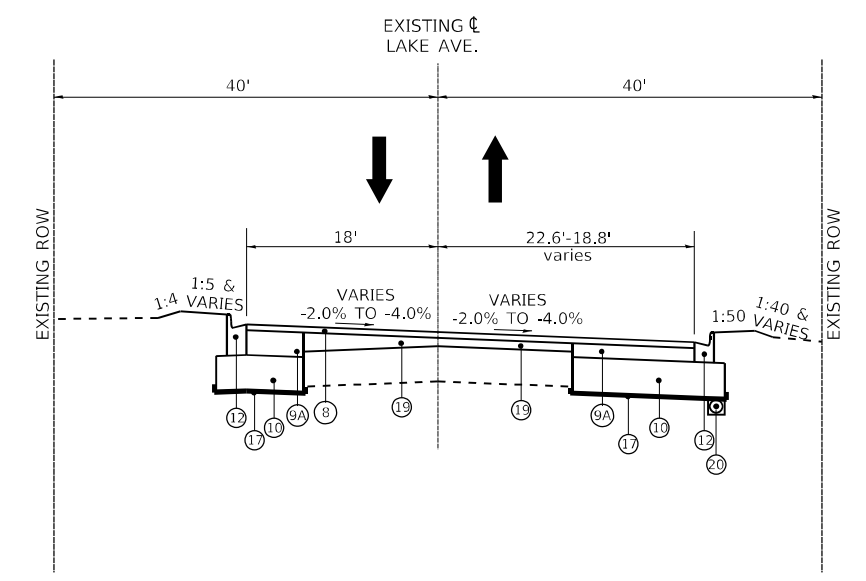

**PROPOSED TYPICAL SECTION
LAKE AVENUE**
STA 201+23 TO STA 201+61
(LOOKING NORTH)
SUPERELEVATED SECTION

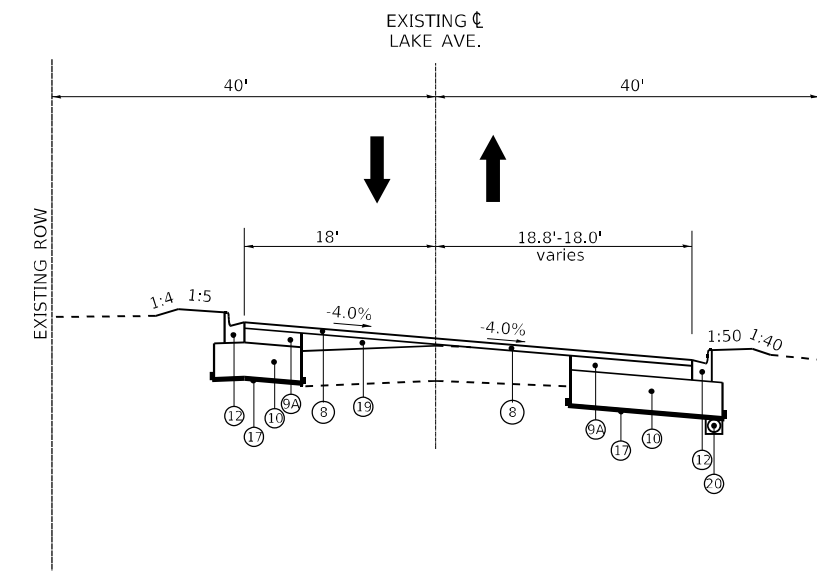

**PROPOSED TYPICAL SECTION
LAKE AVENUE**
STA 201+61 TO STA 202+24
(LOOKING NORTH)
SUPERELEVATED SECTION

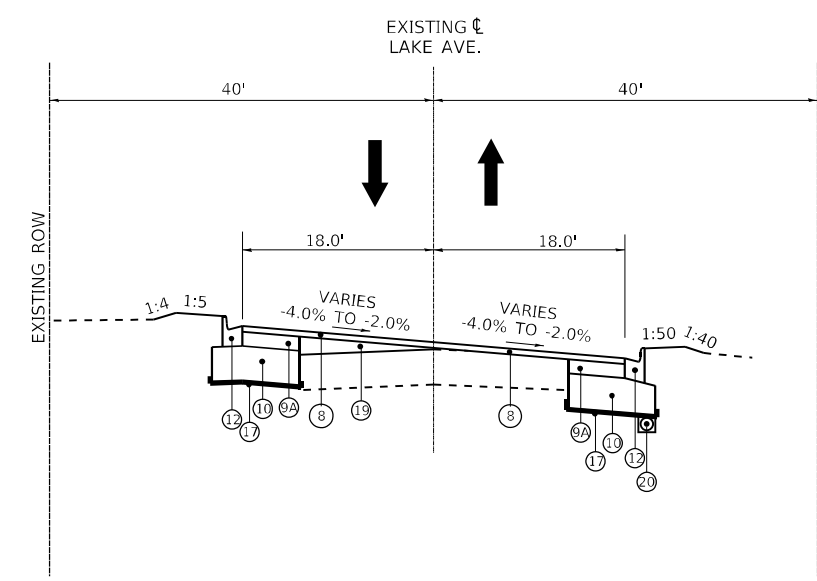

**PROPOSED TYPICAL SECTION
LAKE AVENUE**
STA 202+24 TO STA 202+61
(LOOKING NORTH)
SUPERELEVATED SECTION

LEGEND:

- ① EXISTING AGGREGATE SHOULDER
- ② EXISTING HOT-MIX ASPHALT SHOULDER, 8"
- ③ EXISTING HOT-MIX ASPHALT OVERLAY, 8"
- ④ EXISTING PCC PAVEMENT, 7.5"
- ⑤ EXISTING CURB AND GUTTER
- ⑥ EXISTING HMA PAVEMENT, 4 1/4"
- ⑦ PROPOSED POLYMERIZED HMA SURFACE COURSE, SMA, 9.5, MIX "F", N 80, 1 3/4"
- ⑧ PROPOSED HMA SURFACE COURSE, IL-9.5, MIX "D", N 70, 1 3/4"
- ⑨ PROPOSED HMA BASE COURSE OR BASE COURSE WIDENING, 7 3/4"
- ⑨A PROPOSED HMA BASE COURSE OR BASE COURSE WIDENING, 7 1/2"
- ⑩ PROPOSED AGGREGATE SUBGRADE IMPROVEMENT, 12"
- ⑪ PROPOSED POLYMERIZED HMA BINDER COURSE, IL-4.75, N50, 3/4"
- ⑫ PROPOSED COMBINATION CURB AND GUTTER, TYPE B 6.24
- ⑬ PROPOSED COMBINATION CURB AND GUTTER, TYPE B 6.12
- ⑭ PROPOSED HOT-MIX ASPHALT SURFACE REMOVAL, 2 1/2"
- *⑮ PROPOSED HOT-MIX ASPHALT SURFACE REMOVAL, VARIABLE DEPTH
- ⑯ PROPOSED AGGREGATE SHOULDER REMOVAL, TO BE PAID FOR AS "REMOVAL AND DISPOSAL OF UNSUITABLE MATERIAL"
- ⑰ PROPOSED GEOTECHNICAL FABRIC FOR GROUND STABILIZATION
- ⑱ PROPOSED HMA BINDER COURSE, IL-19.0, N90, 5 1/2"
- ⑱A PROPOSED HMA BINDER COURSE, IL-19.0, N90, VARIABLE DEPTH
- ⑲ PROPOSED HMA BINDER COURSE, IL-19.0, N70, VARIABLE DEPTH
- ⑳ PROPOSED PIPE UNDERDRAINS, TYPE 2, 4"
- ㉑ PROPOSED PAVED SHOULDER REMOVAL
- ㉒ PROPOSED AGGREGATE SHOULDER, TYPE B 10"
- ㉓ PROPOSED CURB AND GUTTER REMOVAL

NOTE:
EXTEND PROPOSED AGGREGATE SUBGRADE IMPROVEMENT 12",
24" BEYOND CURB & GUTTER.

FILE NAME =	USER NAME = kalorm	DESIGNED -	REVISED - RK - 3/15/2021
pw:\planroom.dot\illinois.gov\PIDOT\Documents\IDOT Offices\District 1\Projects\P171909\DRAWING\Design\P171909-sht-typical.dgn		CHECKED -	REVISED -
PLOT SCALE = 100.0000' / in.		DATE -	REVISED -
PLOT DATE = 3/15/2021			

**STATE OF ILLINOIS
DEPARTMENT OF TRANSPORTATION**

IL 173 AT NORTH LAKE AVENUE PROPOSED TYPICAL SECTIONS			
SCALE:	SHEET NO.	OF SHEETS	STA. TO STA.

F.A.P. RTE.	SECTION	COUNTY	TOTAL SHEETS	SHEET NO.
303	(134&134XIN	LAKE	129	20
CONTRACT NO. 60V39				
ILLINOIS FED. AID PROJECT				

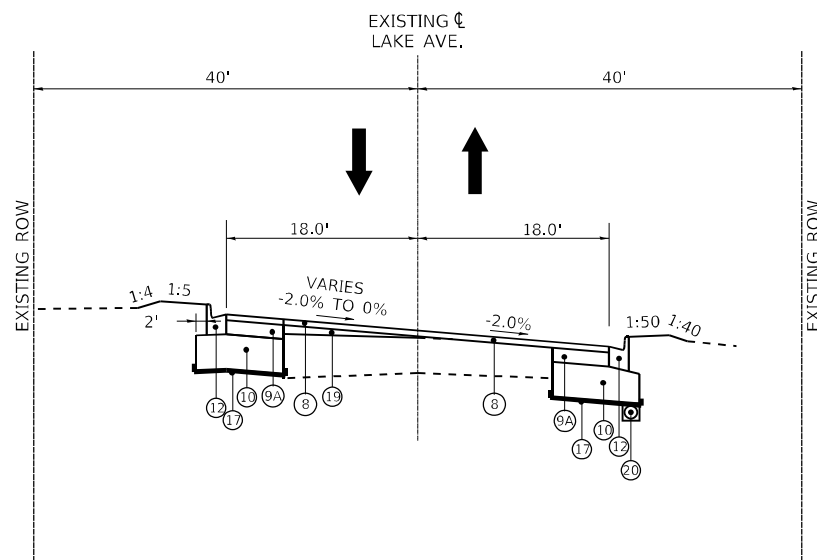

PROPOSED TYPICAL SECTION
LAKE AVENUE
STA 202+61 TO STA 203+00
(LOOKING NORTH)

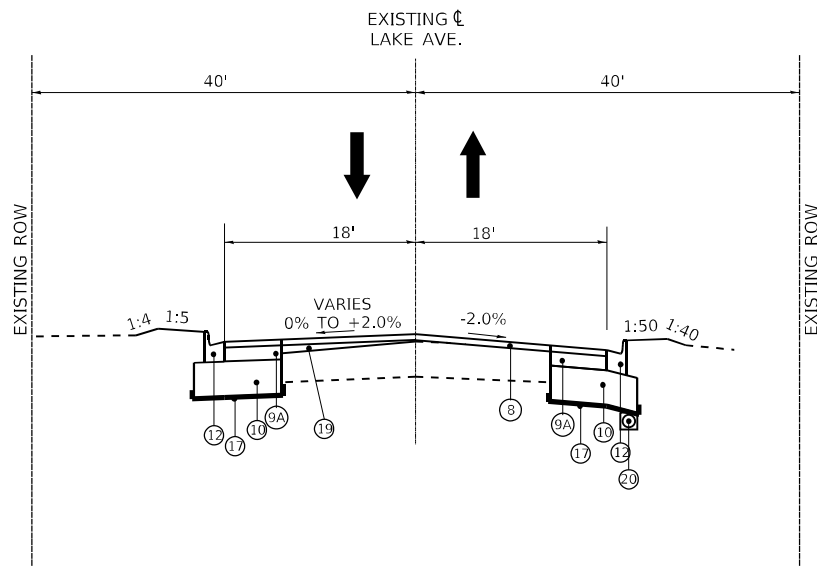

PROPOSED TYPICAL SECTION
LAKE AVENUE
STA 203+00 TO STA 203+39
(LOOKING NORTH)
CROWN SECTION

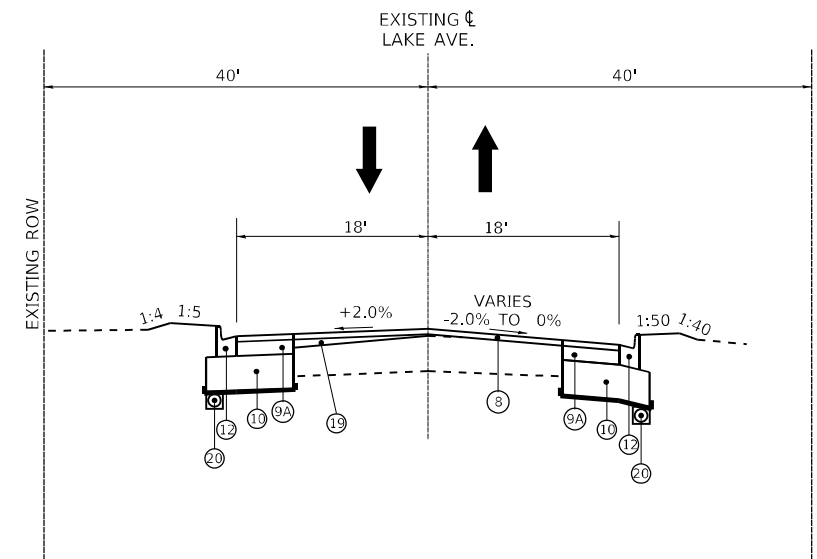

PROPOSED TYPICAL SECTION
LAKE AVENUE
STA 203+39 TO STA 204+45
(LOOKING NORTH)
CROWN SECTION

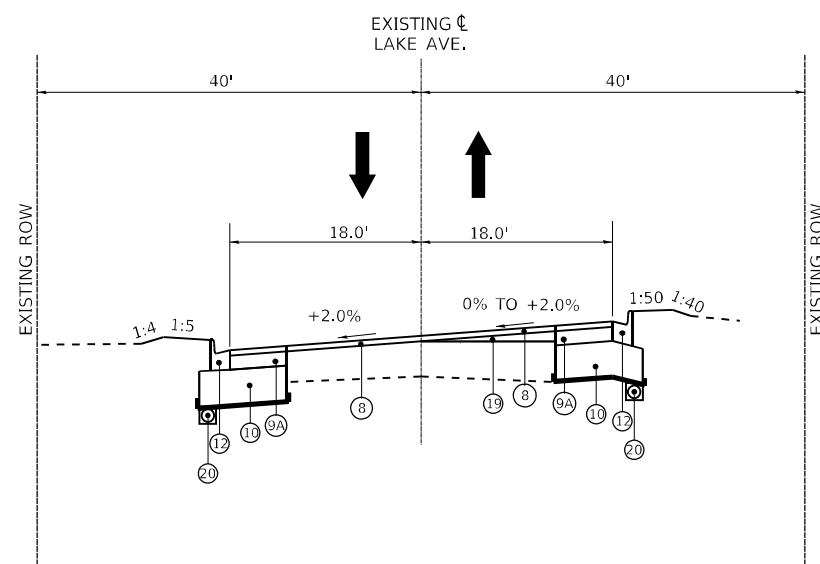

PROPOSED TYPICAL SECTION
LAKE AVENUE
STA 204+45 TO STA 204+84
(LOOKING NORTH)
SUPERELEVATED SECTION

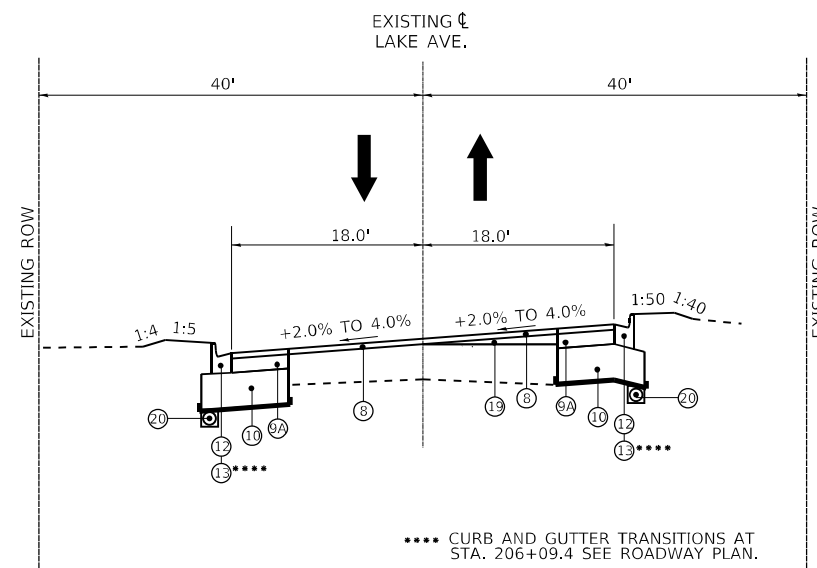

PROPOSED TYPICAL SECTION
LAKE AVENUE
STA 204+84 TO STA 206+78
(LOOKING NORTH)
SUPERELEVATED SECTION

NOTE:
EXTEND PROPOSED AGGREGATE SUBGRADE IMPROVEMENT 12",
24" BEYOND CURB & GUTTER

LEGEND:

- ① EXISTING AGGREGATE SHOULDER
- ② EXISTING HOT-MIX ASPHALT SHOULDER, 8"
- ③ EXISTING HOT-MIX ASPHALT OVERLAY, 8"
- ④ EXISTING PCC PAVEMENT, 7.5"
- ⑤ EXISTING CURB AND GUTTER
- ⑥ EXISTING HMA PAVEMENT, 4 1/4"
- ⑦ PROPOSED POLYMERIZED HMA SURFACE COURSE, SMA, 9.5, MIX "F", N 80, 1 3/4"
- ⑧ PROPOSED HMA SURFACE COURSE, IL-9.5, MIX "D", N 70, 1 3/4"
- ⑨ PROPOSED HMA BASE COURSE OR BASE COURSE WIDENING, 7 3/4"
- ⑨A PROPOSED HMA BASE COURSE OR BASE COURSE WIDENING, 7 1/2"
- ⑩ PROPOSED AGGREGATE SUBGRADE IMPROVEMENT, 12"
- ⑪ PROPOSED POLYMERIZED HMA BINDER COURSE, IL-4.75, N50, 3/4"
- ⑫ PROPOSED COMBINATION CURB AND GUTTER, TYPE B 6.24
- ⑬ PROPOSED COMBINATION CURB AND GUTTER, TYPE B 6.12
- ⑭ PROPOSED HOT-MIX ASPHALT SURFACE REMOVAL, 2 1/2"
- * ⑮ PROPOSED HOT-MIX ASPHALT SURFACE REMOVAL, VARIABLE DEPTH
- ⑯ PROPOSED AGGREGATE SHOULDER REMOVAL, TO BE PAID FOR AS "REMOVAL AND DISPOSAL OF UNSUITABLE MATERIAL"
- ⑰ PROPOSED GEOTECHNICAL FABRIC FOR GROUND STABILIZATION
- ⑱ PROPOSED HMA BINDER COURSE, IL-19.0, N90, 5 1/2"
- ⑱A PROPOSED HMA BINDER COURSE, IL-19.0, N90, VARIABLE DEPTH
- ⑲ PROPOSED HMA BINDER COURSE, IL-19.0, N70, VARIABLE DEPTH
- ⑳ PROPOSED PIPE UNDERDRAINS, TYPE 2, 4"
- ㉑ PROPOSED PAVED SHOULDER REMOVAL
- ㉒ PROPOSED AGGREGATE SHOULDER, TYPE B 10"
- ㉓ PROPOSED CURB AND GUTTER REMOVAL

FILE NAME =	USER NAME = kalorm	DESIGNED -	REVISED - RK - 3/15/2021
pw:\planroom.dot\illinois.gov\PIDOT\Documents\IDOT Offices\District 1\Projects\P171909\Drawings\Design\P171909-sht-typical.dgn		DRAWN -	REVISED -
PLOT SCALE = 100.0000' / in.	CHECKED -	REVISED -	REVISED -
PLOT DATE = 3/15/2021	DATE -	REVISED -	REVISED -

**STATE OF ILLINOIS
DEPARTMENT OF TRANSPORTATION**

**IL 173 AT NORTH LAKE AVENUE
PROPOSED TYPICAL SECTIONS**

SCALE: SHEET NO. OF SHEETS STA. TO STA.

F.A.P. RTE.	SECTION	COUNTY	TOTAL SHEETS	SHEET NO.
303	(134&134XIN)	LAKE	129	21
CONTRACT NO. 60V39				
ILLINOIS FED. AID PROJECT				

1 ILL 173 AT NORTH LAKE AVENUE	2 CUT EARTH EXCAVATION		3 UNSUITABLE MATERIAL		4 FILL EMBANKMENT		5 ADJUSTMENT FOR SHRINKAGE		6 EARTHWORK BALANCE WASTE (+) SHORTAGE (-)		7 TOPSOIL EXCAVATION (EXISTING TOPSOIL) AVERAGE DEPTH = 10"		8 TOPSOIL PLACEMENT DEPTH = 6"		9 TOPSOIL BALANCE WASTE (+) OR SHORTAGE (-)	
	(CU YD)		(CU YD)		(CU YD)		(CU YD)		(CU YD)		(CU YD)		(CU YD)		(CU YD)	
	LEFT STAGE II	RIGHT STAGE III	LEFT STAGE II	RIGHT STAGE III	LEFT STAGE II	RIGHT STAGE III	LEFT STAGE II	RIGHT STAGE III	LEFT STAGE II	RIGHT STAGE III	LEFT STAGE II	RIGHT STAGE III	LEFT STAGE II	RIGHT STAGE III	LEFT STAGE II	RIGHT STAGE III
	North Lake (STA. 200+50 TO STA. 200+78.94)	6	26	0	0	6	6	5.1	22.1	-0.9	16.1	7	25	2	4	5
North Lake (STA. 200+78.94 TO STA. 201+00)	3	17	0	0	3	5	2.6	14.5	-0.5	9.5	4	12	1	3	3	9
North Lake (STA. 201+00 TO STA. 201+50)	9	35	0	0	9	10	7.7	29.8	-1.4	19.8	9	23	10	10	-1	24
North Lake (STA. 201+50 TO STA. 201+89.67)	6	22	0	0	10	9	5.1	18.7	-4.9	9.7	0	12	6	12	-6	18
North Lake (STA. 201+89.67 TO STA. 202+22)	5	12	0	0	7	5	4.3	10.2	-2.8	5.2	8	0	0	6	8	-8
North Lake (STA. 202+22 TO STA. 202+35.73)	3	5	0	0	3	0	2.6	4.3	-0.5	4.3	6	0	1	0	5	-5
North Lake (STA. 202+35.73 TO STA. 202+50)	5	6	0	0	3	0	4.3	5.1	1.3	5.1	6	0	2	0	4	-4
North Lake (STA. 202+50 TO STA. 203+00)	18	22	0	0	9	4	15.3	18.7	6.3	14.7	18	9	6	3	12	-3
North Lake (STA. 203+00 TO STA. 203+50)	16	22	0	0	7	10	13.6	18.7	6.6	8.7	17	20	6	7	11	9
North Lake (STA. 203+50 TO STA. 203+74.71)	9	9	0	0	4	3	7.7	7.7	3.7	4.7	9	5	3	2	6	-1
North Lake (STA. 203+74.71 TO 204+00)	11	10	0	0	4	2	9.4	8.5	5.4	6.5	9	5	3	2	6	-1
North Lake (STA. 204+00 TO STA. 204+50)	20	22	0	0	6	11	17.0	18.7	11.0	7.7	17	21	6	8	11	10
North Lake (STA. 204+50 TO STA. 204+86.5)	14	14	0	0	4	13	11.9	11.9	7.9	-1.1	12	18	4	8	8	10
North Lake (STA. 204+86.5 TO STA. 205+00)	6	4	0	0	2	6	5.1	3.4	3.1	-2.6	4	7	1	3	3	4
North Lake (STA. 205+00 TO STA. 205+50)	20	14	0	0	6	20	17.0	11.9	11.0	-8.1	13	23	5	11	8	15
North Lake (STA. 205+50 TO STA. 206+00)	15	11	0	0	8	20	12.8	9.4	4.8	-10.7	13	22	6	12	7	15
North Lake (STA. 206+00 TO STA. 206+50)	7	5	0	0	10	18	6.0	4.3	-4.1	-13.8	13	19	7	11	6	13
North Lake (STA. 206+50 TO STA. 206+78)	1	0	0	0	5	5	0.9	0.0	-4.2	-5.0	7	7	4	4	3	4
SUB-TOTAL	174	256	0	0	106	147	147.9	217.6	41.9	70.6	172	228	73	106	99	129
	430		0						112.5		400		179		228	

COLUMN 1: LOCATION FROM PLANS

COLUMN 2: CUT QUANTITIES FROM CROSS SECTIONS, WHICH DOES NOT INCLUDE UNSUITABLE MATERIAL

COLUMN 3: CUT MATERIAL THAT IS DETERMINED TO BE EITHER UNSTABLE OR UNSUITABLE FOR USE IN EMBANKMENT, ASSUME 12" OF UNSUITABLE MATERIAL

COLUMN 4: QUANTITIES FROM CROSS SECTIONS (FILL)

COLUMN 5: EARTH EXCAVATION THAT IS TO BE USED AS FILL MATERIAL IN THE EMBANKMENT, SHRINKAGE FACTOR WAS DETERMINED TO BE 15%

COLUMN 6: COLUMN 5 - COLUMN 4, POSITIVE QUANTITY= EXTRA EXCAVATION, NEGATIVE QUANTITY= FURNISHED EXCAVATION NEEDED

COLUMN 7: QUANTITIES OF EXISTING TOPSOIL, TO BE PAID FOR AS "TOPSOIL EXCAVATION AND PLACEMENT"

COLUMN 8: QUANTITIES OF TOPSOIL NEEDED FOR LANDSCAPING = AREA OF SEEDING

COLUMN 9: TOPSOIL REQUIRED (COLUMN 7 - COLUMN 8)

(+) = QUANTITIES OF TOPSOIL TO BE WASTED

(-) = QUANTITIES OF FURNISHED TOPSOIL NEEDED

MODEL: Default
 FILE NAME: p:\data\m3000m.dwg
 PROJECT: P171009\CADD\DATA\Design\171009-01-01-01.dwg

USER NAME = kalorm	DESIGNED -	REVISED - RK-3/15/2021
	DRAWN -	REVISED -
PLOT SCALE = 100,0000' / in.	CHECKED -	REVISED -
PLOT DATE = 3/14/2021	DATE -	REVISED -

**STATE OF ILLINOIS
DEPARTMENT OF TRANSPORTATION**

**IL 173 AT NORTH LAKE AVE.
SCHEDULE OF QUANTITIES (EARTHWORK)**

SCALE: SHEET 2 OF 2 SHEETS STA. TO STA.

F.A.P. RTE.	SECTION	COUNTY	TOTAL SHEETS	SHEET NO.
303	(134&134X)N	LAKE	129	23
CONTRACT NO. 60V39			ILLINOIS FED. AID PROJECT	

TREE REMOVAL (6 TO 15 UNITS DIAMETER)			
STATION	OFFSET (FT)		UNITS
ILL 176			
113+38	24.3	LT	8, 7 MS
113+85	33.4	LT	11
114+01	23.0	LT	9
114+04	20.8	LT	12
114+12	48.3	LT	6
114+26	43.4	LT	6
114+36	33.3	LT	7
114+45	28.8	LT	8
114+72	38.8	LT	8
114+81	30.6	LT	15, 9 MS
114+87	37.3	LT	14
114+88	20.0	LT	15
115+02	28.0	LT	8
115+08	27.0	LT	8
115+15	29.7	LT	9, 9 MS
115+26	35.7	LT	7
115+46	32.4	LT	10, 12 MS
115+56	39.4	LT	13
115+68	32.3	LT	14
115+69	31.2	LT	7
115+81	34.7	LT	9, 9, 11, 11 MS
115+82	33.0	LT	9, 9 MS
116+16	34.3	LT	10, 8 MS
116+17	33.6	LT	10
116+35	26.3	LT	8
116+38	32.3	LT	7, 7 MS
116+42	34.0	LT	14
116+72	43.0	LT	6
116+73	38.7	LT	8, 8 MS
117+28	41.8	LT	14
117+28	39.4	LT	10
117+85	33.5	LT	14
118+53	30.8	LT	10
118+55	30.4	LT	12
118+82	35.7	LT	8
119+50	35.9	LT	10, 10 MS
119+69	34.6	LT	10
119+96	38.4	LT	8
120+20	37.7	LT	10, 8 MS
SUB-TOTAL			386

TREE REMOVAL (OVER 15 UNITS DIAMETER)			
STATION	OFFSET (FT)		UNITS
ILL 176			
207+43	24.4	LT	39
116+35	30.3	LT	18
116+75	32.7	LT	16, 14 MS
117+01	43.3	LT	25, 23 MS
SUB-TOTAL			98

(MS) MULTI-STEMMED TREE

NOTE: TREES ON PRIVATE PROPERTY SHALL NOT BE REMOVED.

EROSION AND SEDIMENT CONTROL SCHEDULE		
LOCATION	INLET FILTERS (EACH)	PERIMETER EROSION BARRIER (FOOT)
STA. 112+26--50.0 LT TO STA. 113+08--50.0 LT		85.8
STA. 113+67-- LT TO STA. 118+50-- LT *		508.4
STA. 113+00--40.0 RT TO STA. 119+70--40 RT		649.3
STA. 204+50.0--40 RT TO STA. 206+50--40 RT		215.2
STA. 107+50, 25.7 ft LT	1.0	
STA. 108+50, 27.4 ft LT	1.0	
STA. 109+50, 29.6 ft LT	1.0	
STA. 109+50, 39.2 ft LT	1.0	
STA. 110+73, 29.7 ft LT	1.0	
STA. 110+73, 43.1 ft LT	1.0	
STA. 113+00, 35.8 ft LT	1.0	
STA. 115+10, 25.2 ft LT	1.0	
STA. 200+84, 19.2 ft LT	1.0	
STA. 201+30, 30.5 ft LT	1.0	
STA. 201+88, 31.1 ft RT	1.0	
STA. 202+03, 18.7 ft RT	1.0	
STA. 203+49, 18.9 ft LT	1.0	
STA. 204+50, 19.0 ft LT	1.0	
TOTAL	14.0	1458.7

* O/S VARY 50' TO 65', SEE EROSION CONTROL PLAN

MODEL: Default
 FILE NAME: \\bluemoon.dot.illinois.gov\PIWDOT\Documents\DOT_Offices\District_1\Projects\IP171909\CADD\DATA\Design\IP171909-etc\schedule.dgn

USER NAME = kalorm	DESIGNED -	REVISED - RK - 3/15/2021
	DRAWN -	REVISED -
PLOT SCALE = 100,0000' / in.	CHECKED -	REVISED -
PLOT DATE = 3/14/2021	DATE -	REVISED -

**STATE OF ILLINOIS
DEPARTMENT OF TRANSPORTATION**

**IL 173 AT NORTH LAKE AVE.
SCHEDULE OF QUANTITIES (TREE REMOVAL & EROSION CONTROL ITEMS)**

SCALE: SHEET 1 OF 1 SHEETS STA. TO STA.

F.A.P. RTE.	SECTION	COUNTY	TOTAL SHEETS	SHEET NO.
303	(134&134X)N	LAKE	129	24
			CONTRACT NO. 60V39	
		ILLINOIS FED. AID PROJECT		

		PT. A = 12 FT LEFT O/S		PT. B = exist. centerline		
		PT. I = VARIABLE DISTANCE LEFT O/S				
VARIABLE MILLING OF WESTBOUND IL 173						
STATION	ELEVATION OF EXISTING PAVEMENT AT PT. A	ELEVATION AFTER MILLING AT PT. A	ELEVATION AFTER MILLING AT PT. I	FEET PT. I LEFT O/S	EXIST. CENTERLINE ELEVATION OF EXISTING PAVEMENT AT PT. B	EXIST. CENTERLINE ELEVATION AFTER MILLING AT PT. B
105+50	747.77	747.53	N/A	N/A	747.98	747.77
106+00	747.84	747.49	N/A	N/A	747.94	747.73
106+42	747.95	747.66	N/A	N/A	747.92	747.71
106+50	747.99	747.70	N/A	N/A	747.91	747.70
107+00	748.14	747.90	N/A	N/A	747.85	747.64
107+23	748.14	747.98	N/A	N/A	747.80	747.59
107+37	748.13	748.03	N/A	N/A	747.78	747.57
107+50	748.14	748.08	N/A	N/A	747.75	747.54
108+00	748.10	NO MILLING	748.07	11.04	747.67	747.46
108+50	748.04	NO MILLING	748.00	10.68	747.62	747.41
109+00	748.10	747.98	N/A	N/A	747.52	747.32
109+50	748.05	747.88	N/A	N/A	747.43	747.22
109+76	748.02	747.85	N/A	N/A	747.40	747.19
110+00	747.93	747.82	N/A	N/A	747.36	747.16
110+25	747.57	NO MILLING	747.60	8.34	747.35	747.14
110+50	747.23	NO MILLING	747.31	4.03	747.30	747.09
111+00	747.12	NO MILLING	747.17	4.09	747.15	746.94
111+50	747.54	747.30	747.50	15.54	746.85	746.64
112+00	747.36	747.18	747.25	15.84	746.73	746.52
112+50	746.72	NO MILLING	746.75	5.72	746.64	746.43
113+00	746.44	NO MILLING	746.55	3.29	746.58	746.37
113+08	746.39	NO MILLING	746.54	3.13	746.58	746.37
113+36	746.29	NO MILLING	746.46	2.79	746.52	746.31
113+50	746.25	NO MILLING	746.44	2.79	746.49	746.28
114+00	746.37	NO MILLING	746.38	3.56	746.40	746.19
114+50	746.38	NO MILLING	746.30	4.21	746.28	746.07
115+00	746.31	NO MILLING	746.24	4.74	746.19	745.98
115+50	746.31	NO MILLING	746.27	4.89	746.21	746.00
116+00	746.61	NO MILLING	746.62	6.15	746.49	746.28
116+50	747.41	NO MILLING	747.40	7.63	747.19	746.98
117+00	748.29	NO MILLING	748.31	6.20	748.17	747.96
117+50	749.14	NO MILLING	749.19	4.65	749.14	748.93
118+00	750.24	NO MILLING	750.29	4.25	750.28	750.06
118+50	751.64	NO MILLING	751.68	5.29	751.73	751.52
119+00	753.40	NO MILLING	753.49	7.28	753.65	753.44
119+50	755.23	755.17	N/A	N/A	755.57	755.36

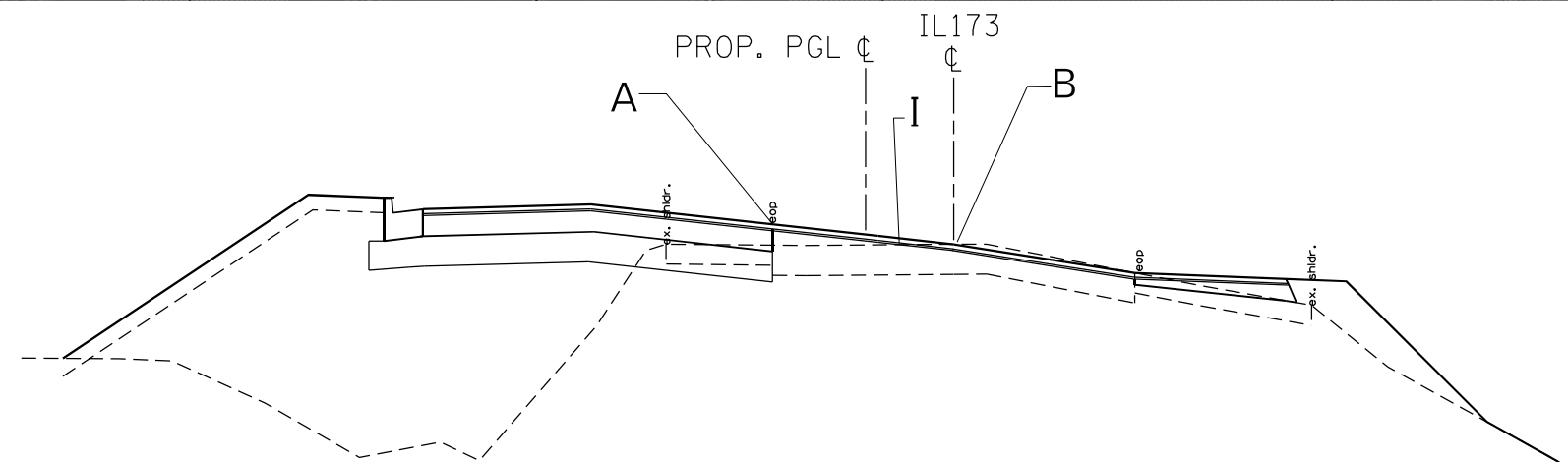

NOTE: TYPICAL SECTION FOR VARIABLE MILLING

		PT. L = 12 FT RIGHT O/S	PT. M = exist. centerline			
		PT. N = 2 FT RIHJT O/S				
VARIABLE MILLING OF EASTBOUND IL 173						
STATION	ELEVATION OF EXISTING PAVEMENT AT PT. L	ELEVATION AFTER MILLING AT PT. L	ELEVATION OF EXISTING PAVEMENT AT PT. N	ELEVATION AFTER MILLING AT PT. N	EXIST. CENTERLINE ELEVATION OF EXISTING PAVEMENT AT PT. M	EXIST. CENTERLINE ELEVATION AFTER MILLING AT PT. M
105+50		HMA SURF. REM. 2.5"		HMA SURF. REM. 2.5"		HMA SURF. REM. 2.5"
106+00		HMA SURF. REM. 2.5"		HMA SURF. REM. 2.5"		HMA SURF. REM. 2.5"
106+42		HMA SURF. REM. 2.5"		HMA SURF. REM. 2.5"		HMA SURF. REM. 2.5"
106+50		HMA SURF. REM. 2.5"		HMA SURF. REM. 2.5"		HMA SURF. REM. 2.5"
107+00		HMA SURF. REM. 2.5"		HMA SURF. REM. 2.5"		HMA SURF. REM. 2.5"
107+23		HMA SURF. REM. 2.5"		HMA SURF. REM. 2.5"		HMA SURF. REM. 2.5"
107+37		HMA SURF. REM. 2.5"		HMA SURF. REM. 2.5"		HMA SURF. REM. 2.5"
107+50		HMA SURF. REM. 2.5"		HMA SURF. REM. 2.5"		HMA SURF. REM. 2.5"
108+00		HMA SURF. REM. 2.5"		HMA SURF. REM. 2.5"		HMA SURF. REM. 2.5"
108+50		HMA SURF. REM. 2.5"		HMA SURF. REM. 2.5"		HMA SURF. REM. 2.5"
109+00		HMA SURF. REM. 2.5"		HMA SURF. REM. 2.5"		HMA SURF. REM. 2.5"
109+50		HMA SURF. REM. 2.5"		HMA SURF. REM. 2.5"		HMA SURF. REM. 2.5"
109+76		HMA SURF. REM. 2.5"		HMA SURF. REM. 2.5"		HMA SURF. REM. 2.5"
110+00		HMA SURF. REM. 2.5"		HMA SURF. REM. 2.5"		HMA SURF. REM. 2.5"
110+25		HMA SURF. REM. 2.5"		HMA SURF. REM. 2.5"		HMA SURF. REM. 2.5"
110+50		HMA SURF. REM. 2.5"		HMA SURF. REM. 2.5"		HMA SURF. REM. 2.5"
111+00		HMA SURF. REM. 2.5"		HMA SURF. REM. 2.5"		HMA SURF. REM. 2.5"
111+50		HMA SURF. REM. 2.5"		HMA SURF. REM. 2.5"		HMA SURF. REM. 2.5"
112+00	746.73	746.52	746.61	746.38	745.90	745.69
112+50	746.64	746.43	746.51	746.29	745.80	745.59
113+00	746.58	746.37	746.55	746.24	745.79	745.58
113+08	746.58	746.37	746.54	746.23	745.75	745.54
113+36	746.52	746.31	746.53	746.16	745.65	745.43
113+50	746.49	746.28	746.51	746.14	745.62	745.41
114+00	746.40	746.19	746.40	746.03	745.45	745.24
114+50	746.28	746.07	746.27	745.91	745.31	745.10
115+00	746.19	745.98	746.10	745.82	745.26	745.05
115+50		HMA SURF. REM. 2.5"		HMA SURF. REM. 2.5"		HMA SURF. REM. 2.5"
116+00		HMA SURF. REM. 2.5"		HMA SURF. REM. 2.5"		HMA SURF. REM. 2.5"
116+50		HMA SURF. REM. 2.5"		HMA SURF. REM. 2.5"		HMA SURF. REM. 2.5"
117+00		HMA SURF. REM. 2.5"		HMA SURF. REM. 2.5"		HMA SURF. REM. 2.5"
117+50		HMA SURF. REM. 2.5"		HMA SURF. REM. 2.5"		HMA SURF. REM. 2.5"
118+00		HMA SURF. REM. 2.5"		HMA SURF. REM. 2.5"		HMA SURF. REM. 2.5"
118+50		HMA SURF. REM. 2.5"		HMA SURF. REM. 2.5"		HMA SURF. REM. 2.5"
119+00		HMA SURF. REM. 2.5"		HMA SURF. REM. 2.5"		HMA SURF. REM. 2.5"
119+50		HMA SURF. REM. 2.5"		HMA SURF. REM. 2.5"		HMA SURF. REM. 2.5"

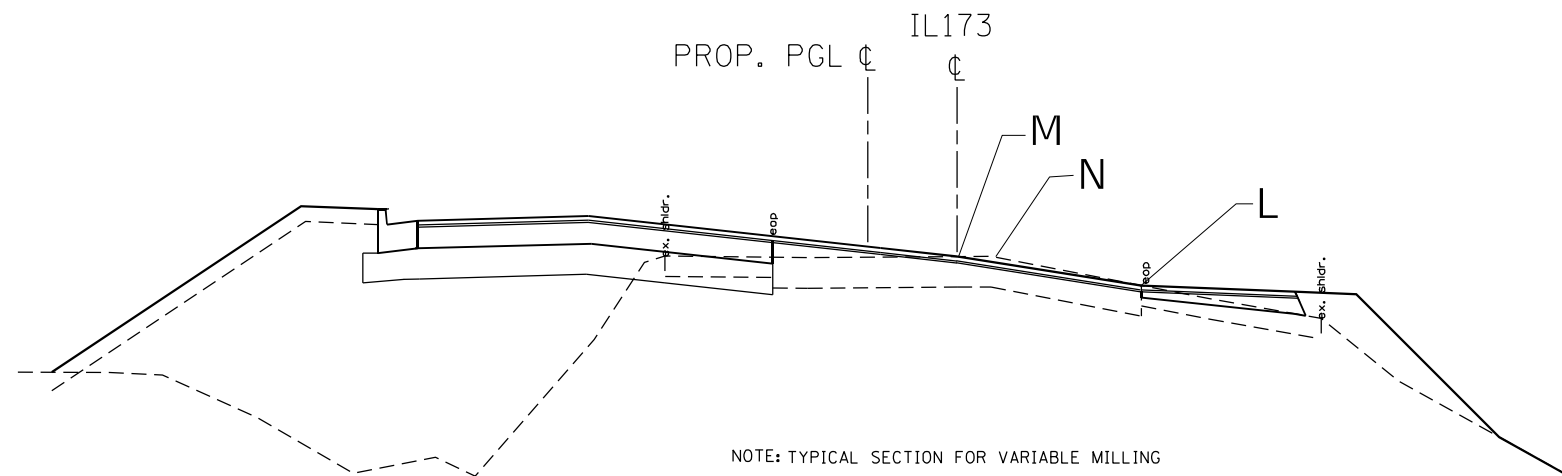

PT. E = 12 FT RIGHT O/S PT. F = EXIST. EDGE OF HMA SHLDR.						
VARIABLE MILLING OF HMA SHOULDER ADJACENT TO E/B IL 173						
STATION	ELEVATION OF EXISTING PAVEMENT AT PT. E	ELEVATION AFTER MILLING AT PT. E	ELEVATION OF EXISTING PAVEMENT AT PT. F	ELEVATION AFTER MILLING AT PT. F	FEET PT. F RIGHT O/S	ELEVATION AFTER BINDER AT PT. F
105+07.7	747.80	747.59	747.72	747.51	16.12	
105+50	747.79	747.58	747.73	747.50	16.18	
106+00	747.76	747.55	747.68	747.47	16.12	
106+42	747.62	747.41	747.54	747.33	16.07	
106+50	747.59	747.38	747.51	747.30	16.08	
107+00	747.36	747.15	747.23	747.07	16.24	
107+23	747.27	747.07	747.04	746.98	16.54	
107+37	747.16	746.95	746.89	746.85	17.03	
107+50	747.07	746.86	746.79	746.76	17.36	
108+00	746.96	746.75	746.64	746.64	17.39	
108+50	746.89	746.68	746.59	746.58	16.85	
109+00	746.78	746.57	746.49	746.48	16.58	
109+50	746.69	746.48	746.40	746.39	16.52	
109+76	746.67	746.46	746.39	746.37	16.50	
110+00	746.64	746.43	746.37	746.34	16.26	
110+25	746.60	746.39	746.31	746.30	16.50	
110+50	746.50	746.30	746.21	746.21	16.43	
111+00	746.41	746.20	746.13	746.11	16.41	
111+50	746.16	745.95	745.83	745.83	17.58	
112+00	745.90	745.50	745.29	745.29	20.29	745.53
112+50	745.80	745.40	745.11	745.11	22.00	745.39
113+00	745.79	745.40	744.99	744.99	22.00	745.39
113+08	745.75	745.36	744.94	744.94	22.00	745.34
113+36	745.65	745.25	744.84	744.84	22.00	745.23
113+50	745.62	745.23	744.78	744.78	22.00	745.21
114+00	745.45	745.06	744.53	744.53	22.00	745.04
114+50	745.31	744.92	744.34	744.34	22.00	744.90
115+00	745.26	744.86	744.31	744.31	22.00	744.85
115+50	745.33	744.67	744.56	744.49	21.12	
116+00		N/A new shoulder		N/A new shoulder		
116+50		N/A new shoulder		N/A new shoulder		
117+00		N/A new shoulder		N/A new shoulder		
117+50		N/A new shoulder		N/A new shoulder		
118+00		N/A 2.5" constant mill		N/A 2.5" constant mill		
118+50		N/A 2.5" constant mill		N/A 2.5" constant mill		
119+00		N/A 2.5" constant mill		N/A 2.5" constant mill		
119+50		N/A 2.5" constant mill		N/A 2.5" constant mill		

NOTE:
STA. 105+07 TO STA. 112+25 RIGHT HMA SHOULDER WILL BE WIDENED TO 10'.
STA. 112+25 TO STA. STA. 115+15.5 EXISTING HMA SHOULDER WILL BE RAISED UP WITH BINDER AND SURFACE.

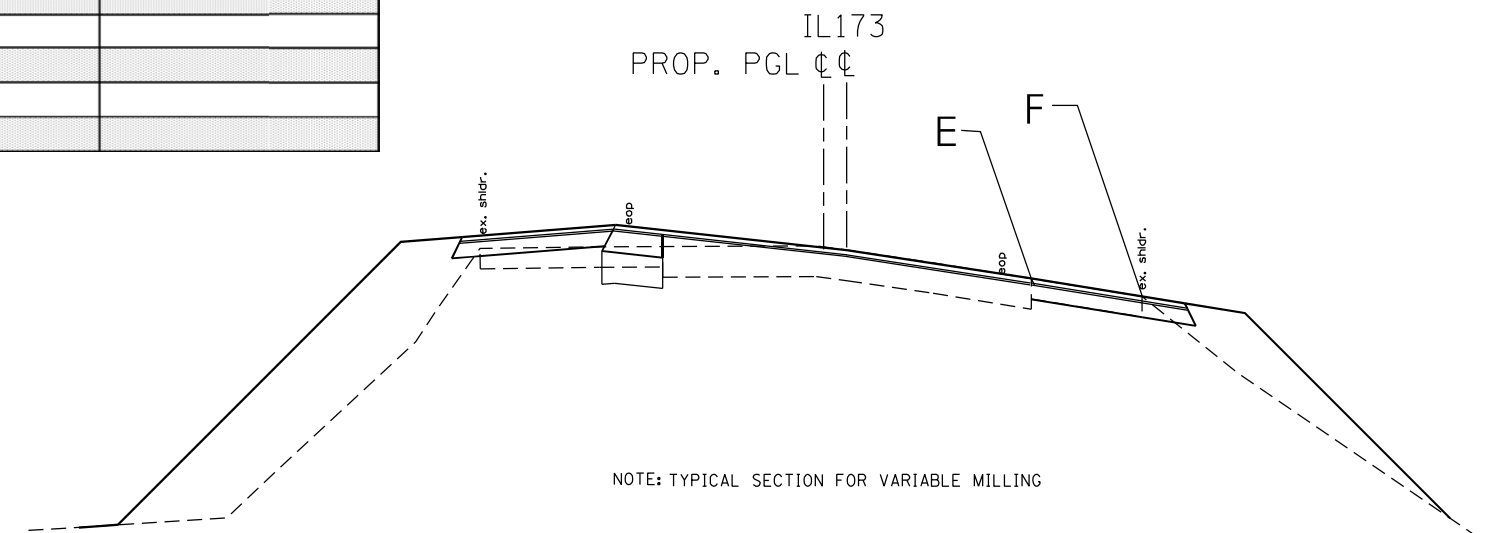

PT. J = 12 FT LEFT O/S						
PT. K = EXIST. EDGE OF HMA SHLDR.						
VARIABLE MILLING OF HMA SHOULDER ADJACENT TO W/B IL 173						
STATION	ELEVATION OF EXISTING PAVEMENT AT PT. K	ELEVATION AFTER MILLING AT PT. K	FEET PT. K LEFT O/S	ELEVATION AFTER BINDER AT PT. K	ELEVATION OF EXISTING PAVEMENT AT PT. J	ELEVATION AFTER MILLING AT PT. J
105+07.7		N/A new shoulder				N/A new shoulder
105+50		N/A new shoulder				N/A new shoulder
106+00		N/A new shoulder				N/A new shoulder
106+42		N/A new shoulder				N/A new shoulder
106+50		N/A new shoulder				N/A new shoulder
107+00		N/A new shoulder				N/A new shoulder
107+23		N/A new shoulder				N/A new shoulder
107+37		N/A new shoulder				N/A new shoulder
107+50		N/A new shoulder				N/A new shoulder
108+00		N/A new shoulder				N/A new shoulder
108+50		N/A new shoulder				N/A new shoulder
109+00		N/A new shoulder				N/A new shoulder
109+50		N/A new shoulder				N/A new shoulder
109+76		N/A new shoulder				N/A new shoulder
110+00		N/A new shoulder				N/A new shoulder
110+25		N/A new shoulder				N/A new shoulder
110+50		N/A new shoulder				N/A new shoulder
111+00		N/A new shoulder				N/A new shoulder
111+50		N/A MID INTERSECTION				N/A MID INTERSECTION
112+00		N/A NO shoulder				N/A NO shoulder
112+50		N/A NO shoulder				N/A NO shoulder
113+00		N/A NO shoulder				N/A NO shoulder
113+08		N/A NO shoulder				N/A NO shoulder
113+36		N/A NO shoulder				N/A NO shoulder
113+50		N/A NO shoulder				N/A NO shoulder
114+00		N/A NO shoulder				N/A NO shoulder
114+50		N/A NO shoulder				N/A NO shoulder
115+00		N/A NO shoulder				N/A NO shoulder
115+50		N/A NO shoulder				N/A NO shoulder
116+00		N/A new shoulder				N/A new shoulder
116+50		N/A NO shoulder				N/A NO shoulder
117+00		N/A new shoulder				N/A new shoulder
117+50		N/A NO shoulder				N/A NO shoulder
118+00		N/A new shoulder				N/A new shoulder
118+50	751.64	751.64	21.95	751.49	751.58	751.31
119+00	753.40	753.40	21.72	753.15	753.19	753.02
119+50	755.23	755.18			754.96	754.80
119+70		N/A 2.5" constant mill				N/A 2.5" constant mill

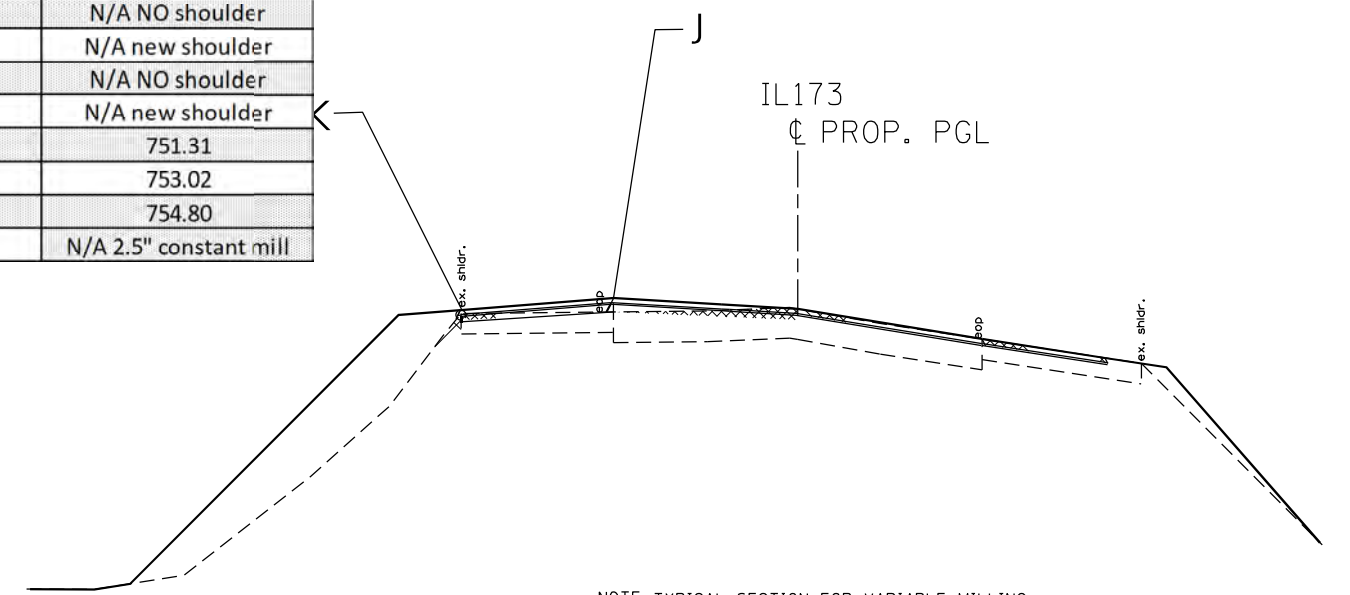

NOTE: TYPICAL SECTION FOR VARIABLE MILLING

FILE NAME =	USER NAME = kalorm	DESIGNED -	REVISED -	STATE OF ILLINOIS DEPARTMENT OF TRANSPORTATION	IL 173 AT NORTH LAKE AVENUE MILLING TABLES			F.A.P. RTE.	SECTION	COUNTY	TOTAL SHEETS	SHEET NO.
pw:\planroom.dot.illinois.gov\PIDOT\Documents\IDOT Offices\District 1\Projects\P171909\DRAWING\Design\P171909-sht-typical.dgn	DRAWN	REVISION	REVISION					303	(134&134X)N	LAKE	129	29
Default	PLOT SCALE = 100.0000' / in.	CHECKED -	REVISION -					CONTRACT NO. 60V39				
	PLOT DATE = 1/27/2021	DATE -	REVISION -					ILLINOIS FED. AID PROJECT				

		pt. C = exist. centerline			PT. D = DISTANCE RIGHT O/S		
		PT. O =DISTANCE RIGHT O/S					
VARIABLE MILLING OF NORTHBOUND NORTH LAKE AVE.							
STATION	EXIST. CENTERLINE ELEVATION OF EXISTING PAVEMENT AT PT. C	EXIST. CENTERLINE ELEVATION AFTER MILLING AT PT. C	ELEVATION AFTER MILLING AT PT. O	FEET PT. O RIGHT O/S	ELEVATION OF EXISTING PAVEMENT AT PT. D	ELEVATION AFTER MILLING AT PT. D	FEET PT. D RIGHT O/S
201+89	746.38	746.38	N/A	N/A	746.06	745.93	14.30
202+22	746.33	746.33	N/A	N/A	745.88	745.77	14.51
202+35	746.36	746.35	N/A	N/A	745.99	745.85	14.67
202+50	746.39	746.38	N/A	N/A	746.10	746.00	14.44
203+00	746.72	746.72	N/A	N/A	746.60	746.56	13.96
203+50	747.31	747.31	N/A	N/A	747.34	747.28	13.44
203+74.7	747.68	747.68	N/A	N/A	747.65	747.62	13.86
204+00	748.20	NO MILL	748.21	2.43	748.23	747.98	14.08
204+50	749.33	749.32	N/A	N/A	749.29	749.29	13.79
204+86.5	750.27	NO MILL	N/A	N/A	750.28	NO MILL	14.10
205+00	750.66	NO MILL	N/A	N/A	750.81	NO MILL	13.98
205+50	752.09	752.08	752.10	0.72	752.55	NO MILL	13.83
206+00	753.32	NO MILL	N/A	N/A	753.83	NO MILL	13.90
206+50	754.13	754.09	754.26	5.31	754.59	754.53	13.91
206+78	754.40	754.26	N/A	N/A	754.74	754.56	13.90

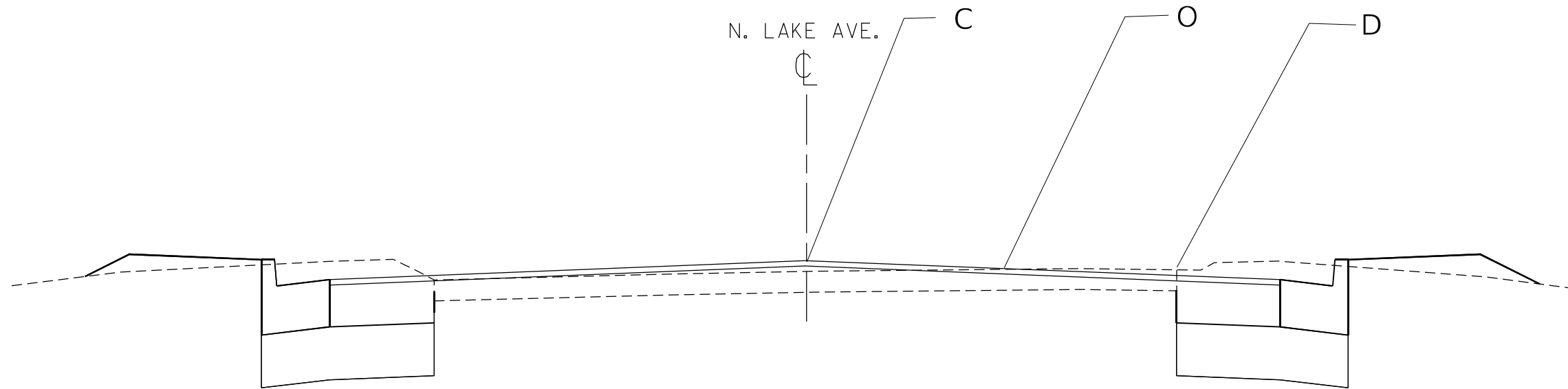

NOTE: TYPICAL SECTION FOR VARIABLE MILLING

FILE NAME =	USER NAME = kalorm	DESIGNED -	REVISED -	STATE OF ILLINOIS DEPARTMENT OF TRANSPORTATION	IL 173 AT NORTH LAKE AVENUE MILLING TABLES			F.A.P. RTE.	SECTION	COUNTY	TOTAL SHEETS	SHEET NO.
pw:\planroom.dot.illinois.gov\PIDOT\Documents\IDOT Offices\District 1\Projects\P171909\DRAWING\Design\P171909-sht-typical.dgn	PLotted	CHECKED -	REVISED -					303	(134&134X)N	LAKE	129	30
Default	PLotted	DATE -	REVISED -					CONTRACT NO. 60V39				ILLINOIS FED. AID PROJECT
				SCALE:	SHEET	OF	SHEETS	STA.	TO	STA.		

		PT. G = exist. centerline		PT. H = DISTANCE LEFT O/S			
		PT. P = DISTANCE LEFT O/S					
VARIABLE MILLING OF SOUTHBOUND NORTH LAKE AVE.							
STATION	ELEVATION OF EXISTING PAVEMENT AT PT. H	ELEVATION AFTER MILLING AT PT. H	FEET PT. H LEFT O/S	ELEVATION AFTER MILLING AT PT. P	FEET PT. P LEFT O/S	EXIST. CENTERLINE VATION OF EXISTING PAVEMENT AT P	EXIST. CENTERLINE ELEVATION AFTER MILLING AT PT. G
204+00	748.04	747.98	14.04	748.14	6.27	748.20	NO MILLING
204+50	749.13	749.04	14.03	N/A	N/A	749.33	749.32
204+86.5	750.00	750.00	14.06	N/A	N/A	750.27	NO MILLING
205+00	750.36	750.28	14.49	750.51	6.60	750.66	NO MILLING
205+50	751.70	751.54	14.14	N/A	N/A	752.09	752.08
206+00	752.88	NO MILLING	14.11	N/A	N/A	753.32	NO MILLING
206+50	753.65	753.63	14.45	N/A	N/A	754.13	754.09
206+78	753.89	753.74	14.37	N/A	N/A	754.40	754.26

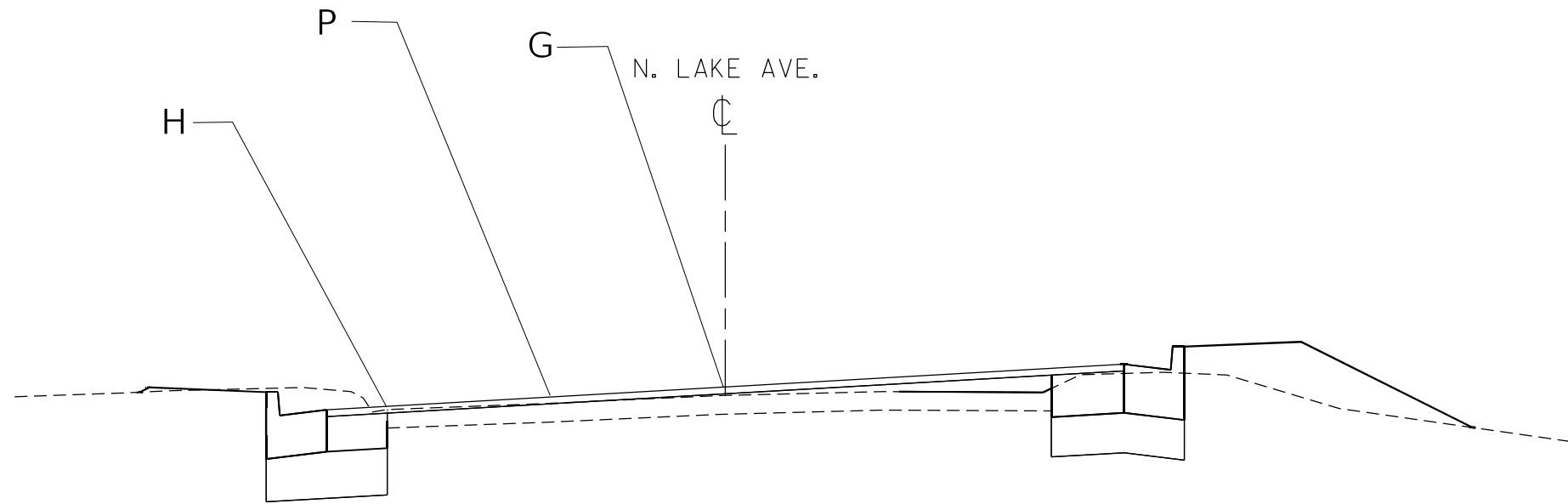

NOTE: TYPICAL SECTION FOR VARIABLE MILLING

FILE NAME =	USER NAME = kalorm	DESIGNED -	REVISED -	STATE OF ILLINOIS DEPARTMENT OF TRANSPORTATION	IL 173 AT NORTH LAKE AVENUE MILLING TABLES			F.A.P. RTE.	SECTION	COUNTY	TOTAL SHEETS	SHEET NO.
pw:\planroom.dot.illinois.gov\PIDOT\Documents\IDOT Offices\District 1\Projects\P171909\DRAWING\Design\P171909-sht-typical.dgn	PLOT SCALE = 100.0000' / in.	CHECKED -	REVISED -					303	(134&134X)N	LAKE	129	31
Default	PLOT DATE = 1/27/2021	DATE -	REVISED -		SCALE: SHEET OF SHEETS STA. TO STA.			CONTRACT NO. 60V39				
ILLINOIS FED. AID PROJECT												

EXIST. CURVE CLLAKE-1
 PI STA. = 200+73.07
 I = 20° 59' 25" (RT)
 D = 26° 02' 37"
 R = 220.00'
 T = 40.76'
 L = 80.60'
 E = 3.74'
 e = _____
 T.R. = _____
 S.E. RUN = _____
 P.C. STA. = 200+32.31
 P.T. STA. = 201+12.91

EXIST. CURVE CLLAKE-2
 PI STA. = 201+92.93
 I = 18° 30' 18" (RT)
 D = 16° 22' 13"
 R = 350.00'
 T = 57.02'
 L = 113.04'
 E = 4.61'
 e = _____
 T.R. = _____
 S.E. RUN = _____
 P.C. STA. = 201+35.91
 P.T. STA. = 202+48.95

EXIST. CURVE CL173-2
 PI STA. = 122+63.93
 I = 10° 33' 21" (LT)
 D = 5° 43' 46"
 R = 1,000.00'
 T = 92.38'
 L = 184.24'
 E = 4.26'
 e = _____
 T.R. = _____
 S.E. RUN = _____
 P.C. STA. = 121+71.55
 P.T. STA. = 123+55.79

EXIST. CURVE CL173-1
 PI STA. = 113+45.84
 I = 62° 41' 52" (RT)
 D = 5° 41' 52"
 R = 1,005.60'
 T = 612.59'
 L = 1,100.41'
 E = 171.90'
 e = _____
 T.R. = _____
 S.E. RUN = _____
 P.C. STA. = 107+33.25
 P.T. STA. = 118+33.66

EXIST. CURVE CLLAKE-3
 PI STA. = 206+83.96
 I = 50° 12' 25" (LT)
 D = 14° 19' 26"
 R = 400.00'
 T = 187.40'
 L = 350.51'
 E = 41.72'
 e = _____
 T.R. = _____
 S.E. RUN = _____
 P.C. STA. = 204+96.56
 P.T. STA. = 208+47.07

CONTROL POINTS

CP#	N	E	ELEV.
CP# 101	N 2116471.935	E 1033660.318	ELEV. = 756.22
CP# 102	N 2116348.314	E 1031846.240	ELEV. = 748.11
CP# 103	N 2116322.533	E 1032352.820	ELEV. = 747.71
CP# 104	N 2116166.492	E 1033055.207	ELEV. = 747.26
CP# 105	N 2115620.162	E 1033385.305	ELEV. = 748.88
CP# 106	N 2115019.472	E 1033632.433	ELEV. = 771.61

BENCHMARKS AND CONTROL POINTS ARE THE SAME.

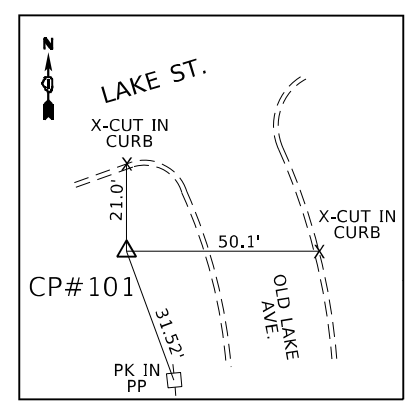

CP#101
I.R. & CAP

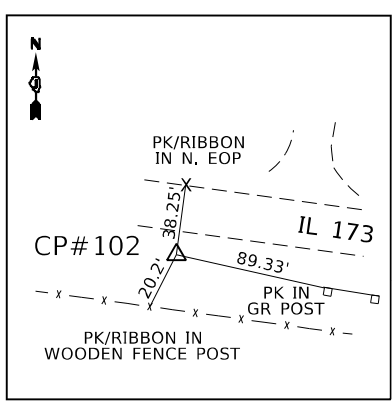

CP#102
I.R. & CAP

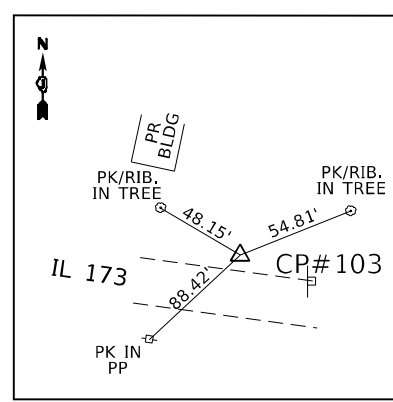

CP#103
I.R. & CAP

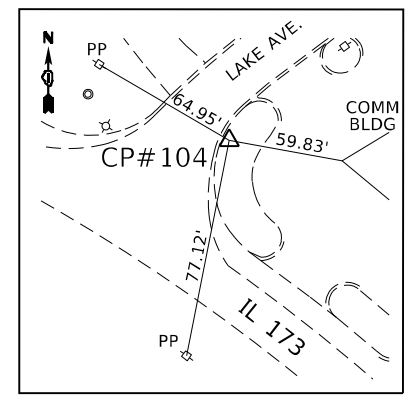

CP#104
I.R. & CAP

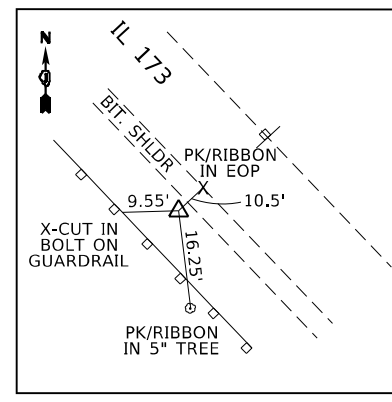

CP#105
I.R. & CAP
±600' EAST OF LAKE AVE.

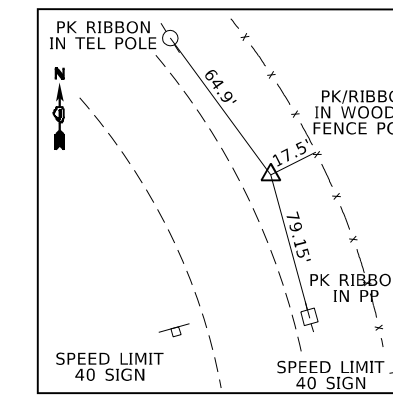

CP#106
I.R. & CAP

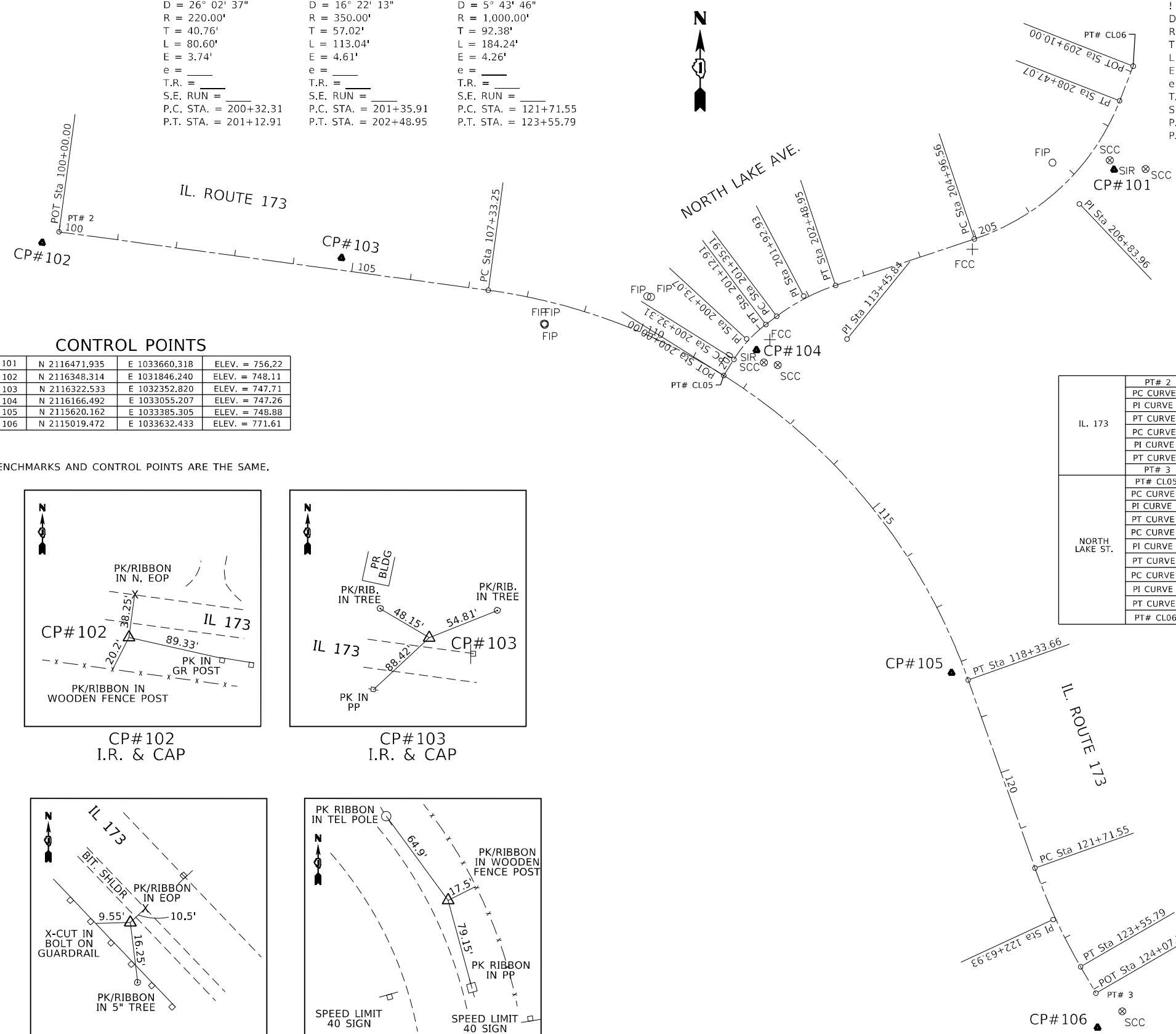

IL. 173	PT# 2	N 2116366.6258	E 1031874.8685	STA. 100+00
	PC CURVE 1	N 2116267.7422	E 1032601.4204	STA. 107+33.25
	PI CURVE 1	N 2116185.1302	E 1033208.4158	STA. 113+45.84
	PT CURVE 1	N 2115607.8612	E 1033413.4250	STA. 118+33.66
	PC CURVE 2	N 2115289.4543	E 1033526.5028	STA. 121+71.55
	PI CURVE 2	N 2115202.4017	E 1033557.4184	STA. 122+63.93
	PT CURVE 2	N 2115122.4859	E 1033603.7583	STA. 123+55.79
	PT# 3	N 2115077.8442	E 1033629.6442	STA. 124+07.39
	PT# CL05	N 2116123.4117	E 1032999.8357	STA. 200+00
	PC CURVE 1	N 2116150.8043	E 1033016.9729	STA. 200+32.31
	PI CURVE 1	N 2116185.3552	E 1033038.5884	STA. 200+73.07
	PT CURVE 1	N 2116209.8704	E 1033071.1460	STA. 201+12.91
	PC CURVE 2	N 2116223.7087	E 1033089.5240	STA. 201+35.91
	PI CURVE 2	N 2116258.0054	E 1033135.0720	STA. 201+92.93
	PT CURVE 2	N 2116276.0726	E 1033189.1502	STA. 201+48.95
	PC CURVE 3	N 2116354.5331	E 1033423.9962	STA. 204+96.56
	PI CURVE 3	N 2116413.9168	E 1033601.7419	STA. 206+83.96
	PT CURVE 3	N 2116588.4961	E 1033669.8740	STA. 208+47.07
	PT# CL06	N 2116647.1224	E 1033692.7538	STA. 209+10.00

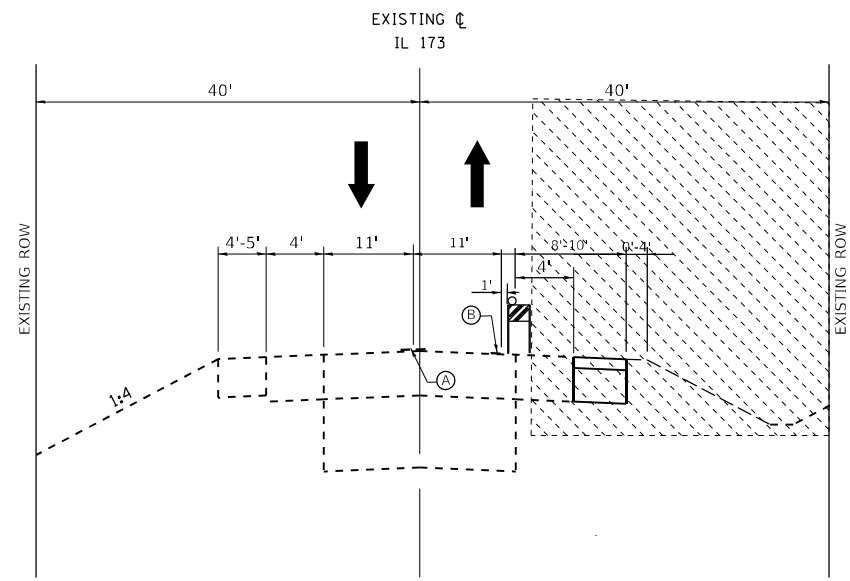

EXISTING TYPICAL SECTION
ILLINOIS ROUTE 173
STA. 105+07.7 TO STA 106+42
STA 113+65 to STA 119+70
(LOOKING EAST)
CROWN SECTION

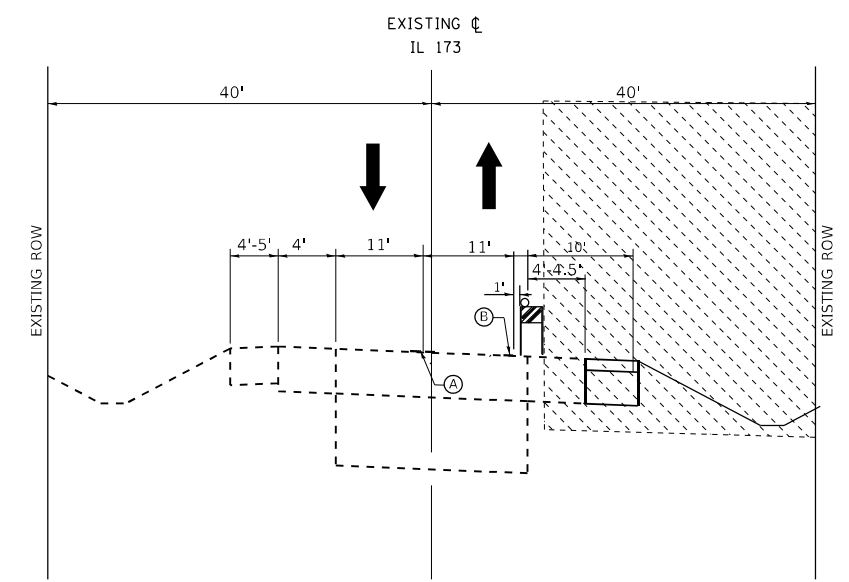

EXISTING TYPICAL SECTION
ILLINOIS ROUTE 173
STA. 109+50 TO STA 113+65
(LOOKING EAST)

STAGE 1 (SOUTH SIDE CONSTRUCTION):

- PROVIDE ONE TRAVEL LANES IN EACH DIRECTION WITH 11' WIDTH
- PLACE DRUMS OR TYPE II BARRICADES TO PROTECT TRAFFIC FROM THE CONSTRUCTION ZONE
- CONSTRUCT PROPOSED DRAINAGE ALONG THE SOUTH SIDE OF IL 173
- CONSTRUCT THE WIDENING ON THE SOUTH SIDE OF IL 173
- CONSTRUCT TRAFFIC SIGNAL ON THE SOUTH SIDE OF IL 173
- CONSTRUCT PERMANENT SHEET PILE RETAINING WALL
- CONSTRUCT FINAL GRADING AND INSTALL TEMPORARY SEEDING OR PERMANENT LANDSCAPING ON THE SOUTH SIDE OF IL 173

NOTE: THESE ARE SUGGESTED STAGING TYPICAL SECTIONS

LEGEND:

- Ⓐ TEMPORARY PAVEMENT MARKING, TAPE TYPE IV
4" SOLID DOUBLE YELLOW @ 11" C-C
- Ⓑ TEMPORARY PAVEMENT MARKING, TAPE TYPE IV
4" SOLID WHITE EDGE LINE
- WORK ZONE
- DRUMS OR TY II BARRICADE AT 50 FT SPACING
DEVICES IN TAPER (20 FT C-C)
DEVICES IN CURVES & RADII (25 FT C-C)

NOTES:

TRAFFIC ALONG IL 173 AND N LAKE AVE. SHALL BE MAINTAINED DURING THE WIDENING AND RESURFACING OPERATIONS BY STAGING THE CONSTRUCTION.

THE CONTRACTOR SHALL BACKFILL ALL LOCATIONS WHERE THERE IS NO TCB WALL AND THE DROP OFF \geq 18" WITHIN 8' OF THE EDGE OF PAVEMENT.

MODEL: Default
FILE NAME: p:\data\mroom.dwg
PROJECT: P171099\CADD\DATA\Design\171099-01-01.dwg

USER NAME = kalorm	DESIGNED -	REVISED -
	DRAWN -	REVISED -
PLOT SCALE = 100,0000' / in.	CHECKED -	REVISED -
PLOT DATE = 1/27/2021	DATE -	REVISED -

**STATE OF ILLINOIS
DEPARTMENT OF TRANSPORTATION**

**IL 173 AT NORTH LAKE AVE.
STAGE I TYPICAL SECTIONS**

SCALE: SHEET 1 OF 2 SHEETS STA. TO STA.

F.A.P. RTE.	SECTION	COUNTY	TOTAL SHEETS	SHEET NO.
303	(134&134X)N	LAKE	129	33
CONTRACT NO. 60V39			ILLINOIS FED. AID PROJECT	

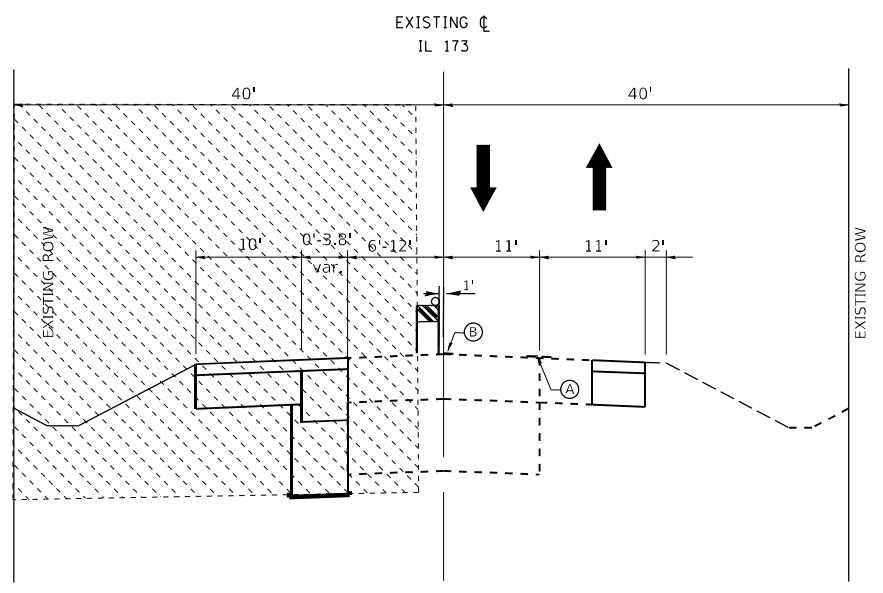

PROPOSED TYPICAL SECTION
ILLINOIS ROUTE 173
STA. 105+07.7 TO STA 106+07
(LOOKING EAST)
CROWN SECTION

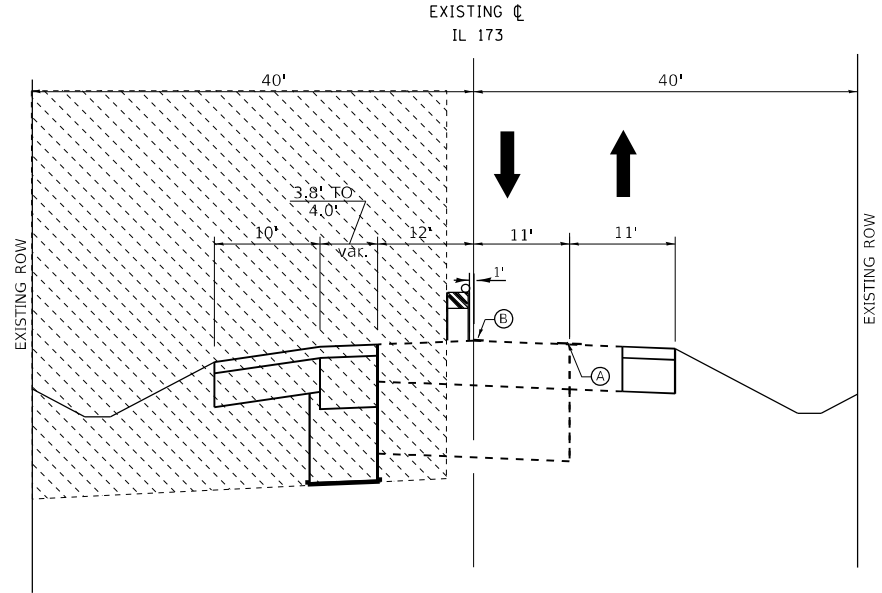

PROPOSED TYPICAL SECTION
ILLINOIS ROUTE 173
STA. 106+07 TO STA 106+50
(LOOKING EAST)

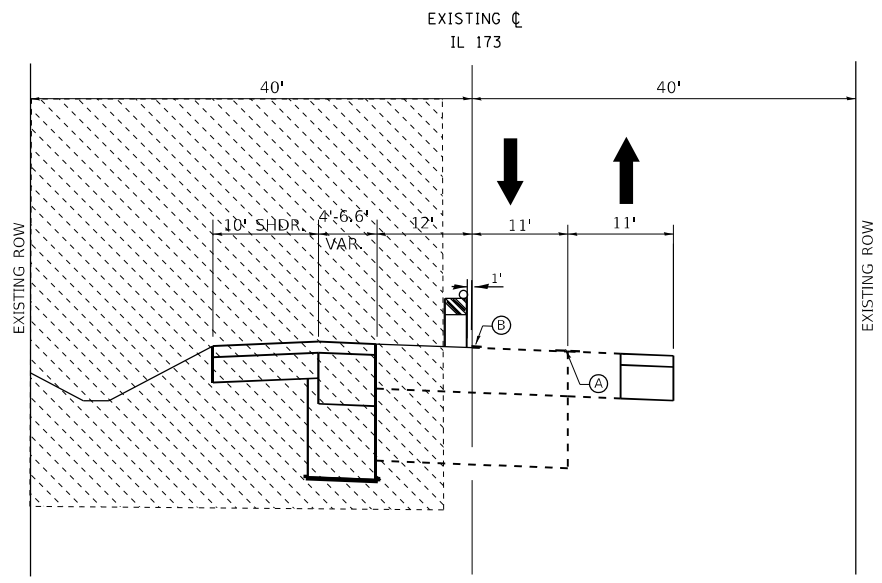

PROPOSED TYPICAL SECTION
ILLINOIS ROUTE 173
STA. 106+50 TO STA 107+38.7
(LOOKING EAST)

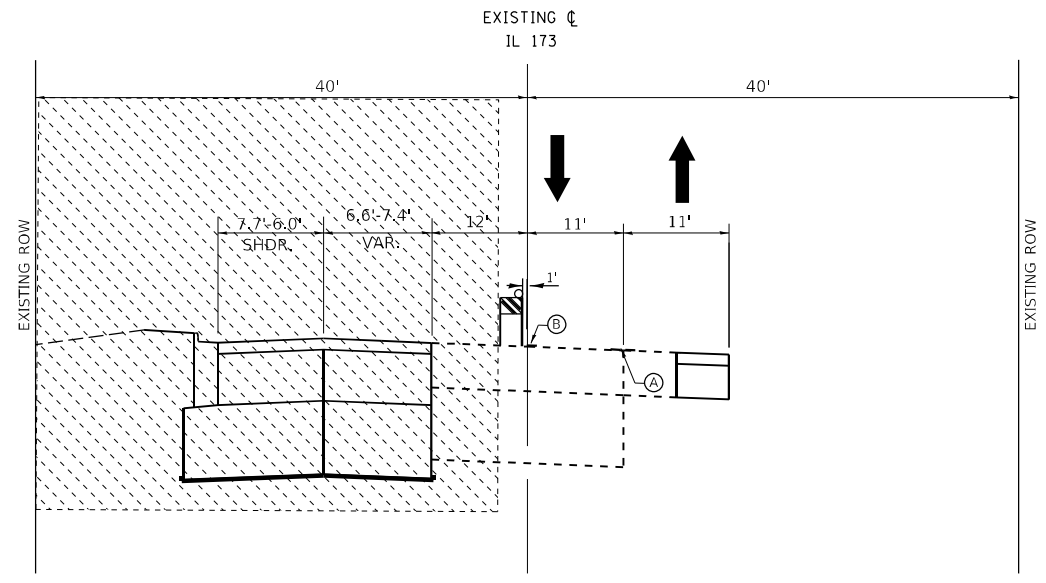

PROPOSED TYPICAL SECTION
ILLINOIS ROUTE 173
STA. 107+43.3 TO STA 107+70.5
(LOOKING EAST)
SUPERELEVATED SECTION

STAGE 2 (NORTH SIDE CONSTRUCTION):

- PROVIDE ONE TRAVEL LANES IN EACH DIRECTION WITH 11' WIDTH
- PLACE DRUMS OR TYPE II BARRICADES TO PROTECT TRAFFIC FROM THE CONSTRUCTION ZONE
- CONSTRUCT PROPOSED DRAINAGE ALONG THE NORTH SIDE OF IL 173
- CONSTRUCT THE WIDENING ON THE NORTH SIDE OF IL 173
- CONSTRUCT TRAFFIC SIGNAL AND CURB AND GUTTER ON THE NORTH SIDE OF IL 173
- CONSTRUCT PERMANENT SHEET PILE RETAINING WALL
- CONSTRUCT FINAL GRADING AND INSTALL TEMPORARY SEEDING OR PERMANENT LANDSCAPING ON THE NORTH SIDE OF IL 173

NOTE: THESE ARE SUGGESTED STAGING TYPICAL SECTIONS

LEGEND:

- (A) TEMPORARY PAVEMENT MARKING, TAPE TYPE IV
4" SOLID DOUBLE YELLOW @ 11" C-C
- (B) TEMPORARY PAVEMENT MARKING, TAPE TYPE IV
4" SOLID WHITE EDGE LINE
- WORK ZONE
- DRUMS OR TY II BARRICADE AT 50 FT SPACING
DEVICES IN TAPER (20 FT C-C)
DEVICES IN CURVES & RADII (25 FT C-C)

NOTES:

TRAFFIC ALONG IL 173 AND N LAKE AVE. SHALL BE MAINTAINED DURING THE WIDENING AND RESURFACING OPERATIONS BY STAGING THE CONSTRUCTION.

THE CONTRACTOR SHALL BACKFILL ALL LOCATIONS WHERE THERE IS NO TCB WALL AND THE DROP OFF \geq 18" WITHIN 8' OF THE EDGE OF PAVEMENT.

MODEL: Default
FILE NAME: p:\data\room.dwg\illinois\dot\Documents\DOT_Offices\Distric: 1\Projects\171909\ICADD\DATA\Design\171909-rlt-ctb.dwg

USER NAME = kalorm	DESIGNED -	REVISED -
PLOT SCALE = 100,0000' / in.	DRAWN -	REVISED -
PLOT DATE = 1/27/2021	CHECKED -	REVISED -
	DATE -	REVISED -

**STATE OF ILLINOIS
DEPARTMENT OF TRANSPORTATION**

IL 173 AT NORTH LAKE AVE. STAGE II TYPICAL SECTIONS	
SCALE:	SHEET 2 OF 2 SHEETS
STA.	TO STA.

F.A.P. RTE.	SECTION	COUNTY	TOTAL SHEETS	SHEET NO.
303	(134&134X)N	LAKE	129	34
CONTRACT NO. 60V39				
ILLINOIS FED. AID PROJECT				

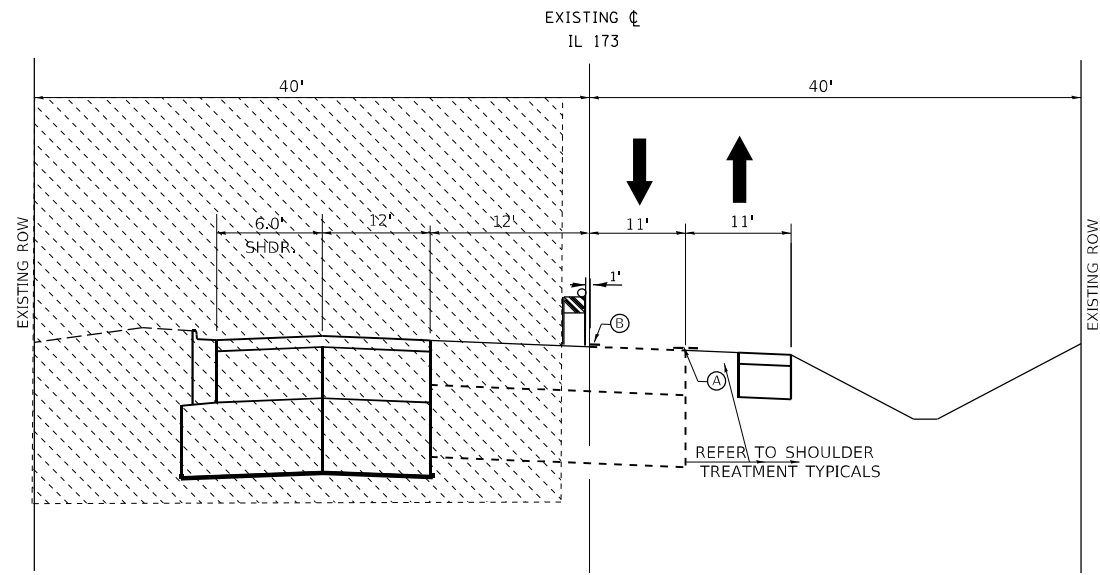

PROPOSED TYPICAL SECTION
ILLINOIS ROUTE 173

STA 107+70.5 TO STA 110+75
(LOOKING EAST)
SUPERELEVATED SECTION

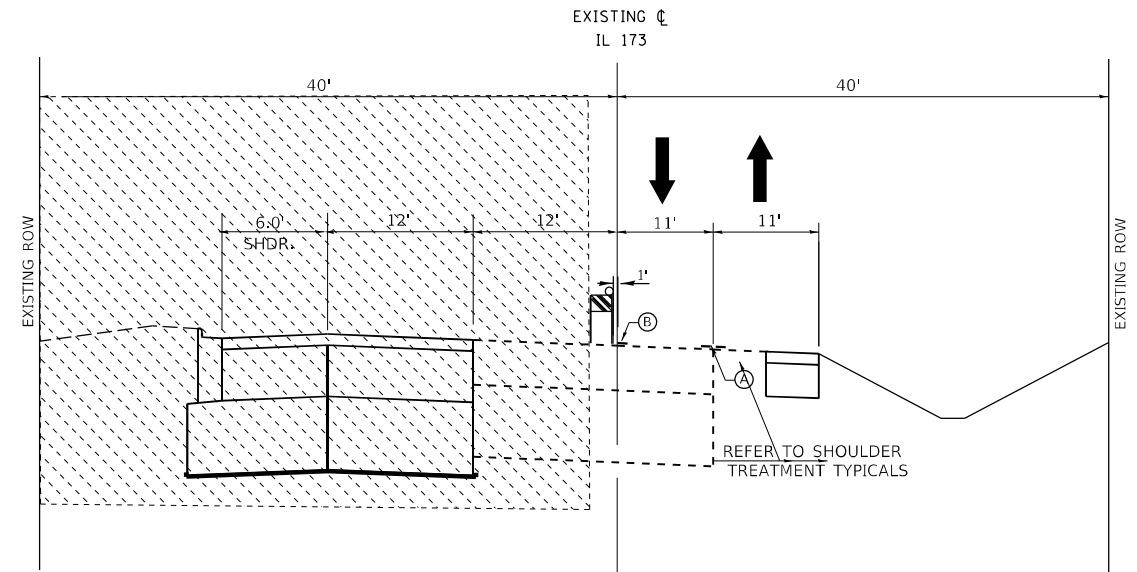

PROPOSED TYPICAL SECTION
ILLINOIS ROUTE 173

STA 110+75 TO STA 111+50
(LOOKING EAST)
SUPERELEVATED SECTION

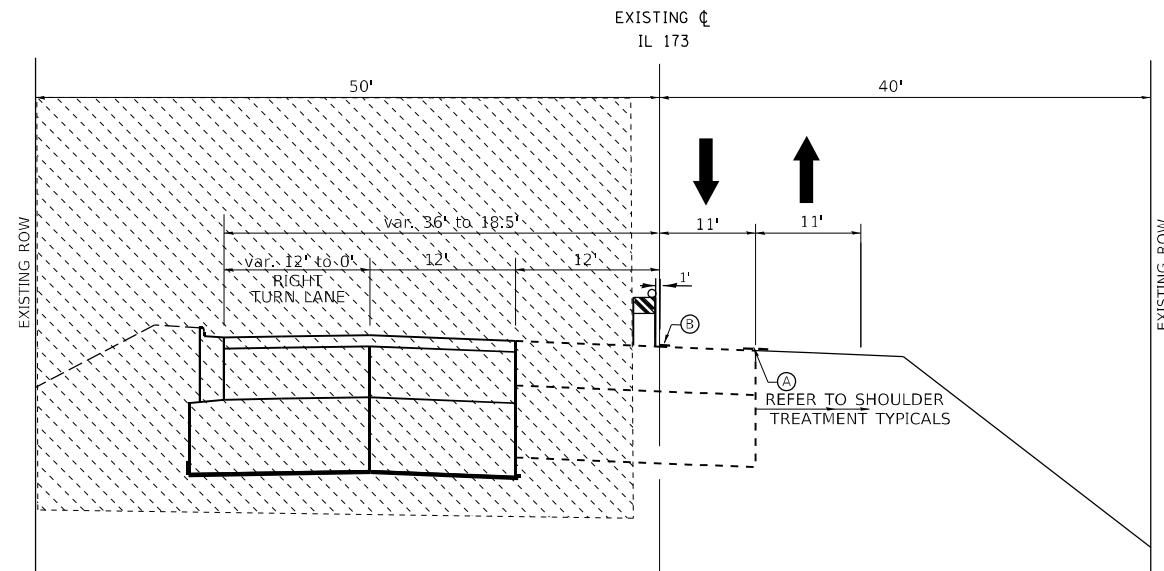

PROPOSED TYPICAL SECTION
ILLINOIS ROUTE 173

STA 111+50 TO STA. 115+92.4
(LOOKING EAST)
SUPERELEVATED SECTION

STAGE 2 (NORTH SIDE CONSTRUCTION):

- PROVIDE ONE TRAVEL LANES IN EACH DIRECTION WITH 11' WIDTH
- PLACE DRUMS OR TYPE II BARRICADES TO PROTECT TRAFFIC FROM THE CONSTRUCTION ZONE
- CONSTRUCT PROPOSED DRAINAGE ALONG THE NORTH SIDE OF IL 173
- CONSTRUCT THE WIDENING ON THE NORTH SIDE OF IL 173
- CONSTRUCT TRAFFIC SIGNAL AND CURB AND GUTTER ON THE NORTH SIDE OF IL 173
- CONSTRUCT PERMANENT SHEET PILE RETAINING WALL
- CONSTRUCT FINAL GRADING AND INSTALL TEMPORARY SEEDING OR PERMANENT LANDSCAPING ON THE NORTH SIDE OF IL 173

NOTE: THESE ARE SUGGESTED STAGING TYPICAL SECTIONS

LEGEND:

- (A) TEMPORARY PAVEMENT MARKING, TAPE TYPE IV
4" SOLID DOUBLE YELLOW @ 11" C-C
- (B) TEMPORARY PAVEMENT MARKING, TAPE TYPE IV
4" SOLID WHITE EDGE LINE
- WORK ZONE
- DRUMS OR TY II BARRICADE AT 50 FT SPACING
DEVICES IN TAPER (20 FT C-C)
DEVICES IN CURVES & RADII (25 FT C-C)

NOTES:

TRAFFIC ALONG IL 173 AND N LAKE AVE. SHALL BE MAINTAINED DURING THE WIDENING AND RESURFACING OPERATIONS BY STAGING THE CONSTRUCTION.

THE CONTRACTOR SHALL BACKFILL ALL LOCATIONS WHERE THERE IS NO TCB WALL AND THE DROP OFF \geq 18" WITHIN 8' OF THE EDGE OF PAVEMENT.

MODEL: Default
 FILE NAME: p:\data\m3000\dot\illinois\dot\p11009\dot\documents\dot\office\dot\stage 2\stage 2\stage 2.dgn

USER NAME = kalorm	DESIGNED -	REVISED -
	DRAWN -	REVISED -
PLOT SCALE = 100,0000' / in.	CHECKED -	REVISED -
PLOT DATE = 1/27/2021	DATE -	REVISED -

STATE OF ILLINOIS
DEPARTMENT OF TRANSPORTATION

IL 173 AT NORTH LAKE AVE.
STAGE II TYPICAL SECTIONS

SCALE: SHEET 2 OF 2 SHEETS STA. TO STA.

F.A.P. RTE.	SECTION	COUNTY	TOTAL SHEETS	SHEET NO.
303	(134&134X)N	LAKE	129	35
CONTRACT NO. 60V39			ILLINOIS FED. AID PROJECT	

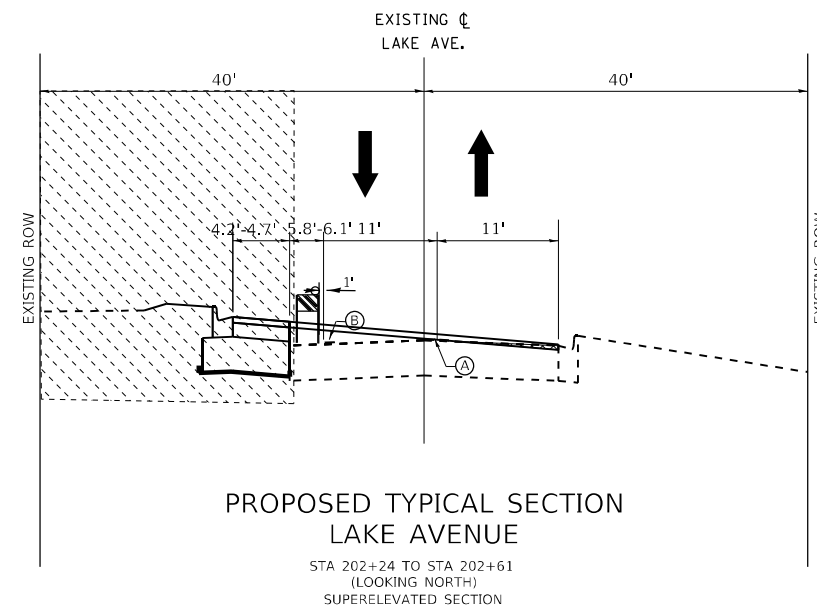
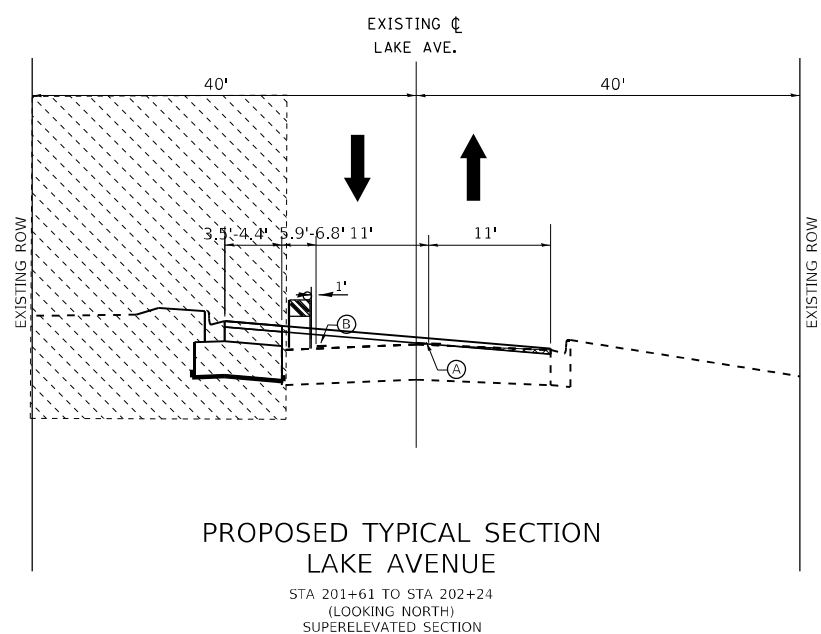
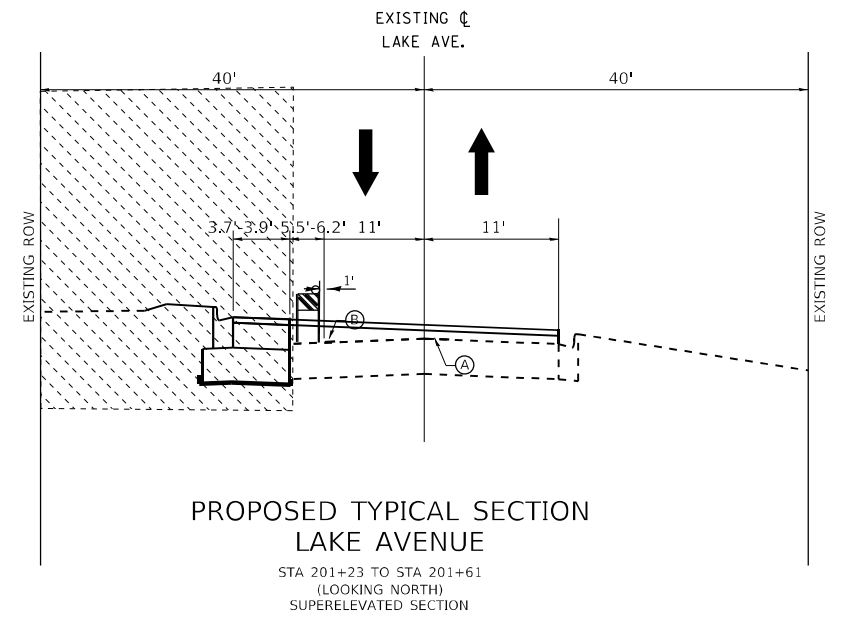
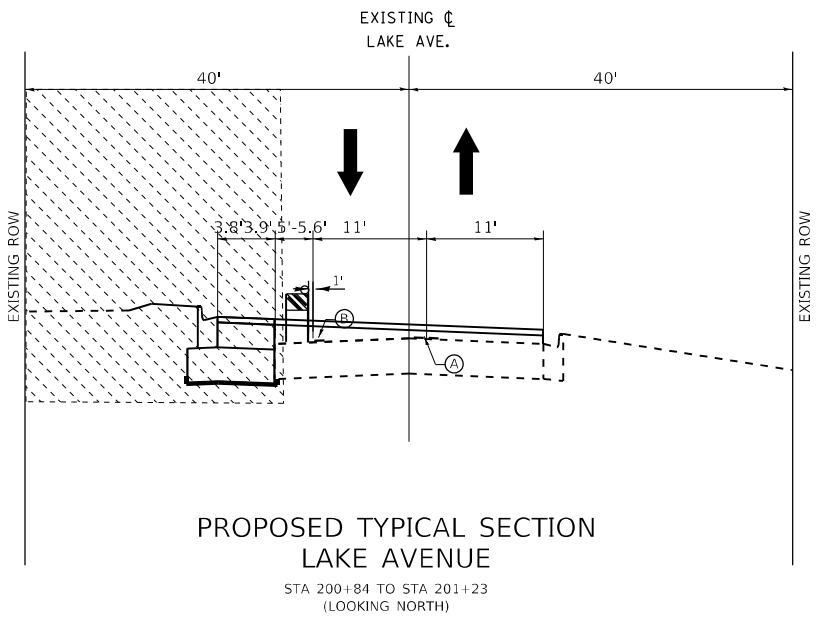
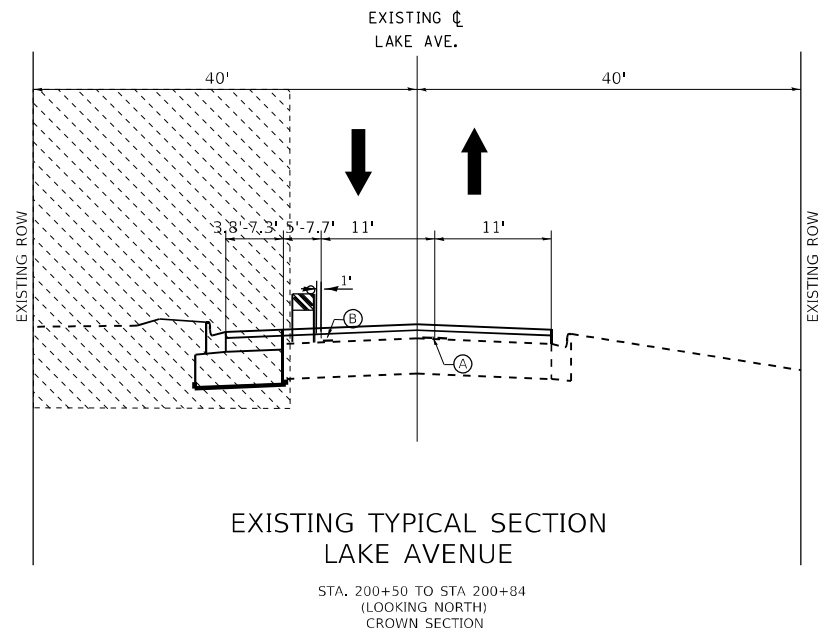

STAGE 2 (WEST SIDE CONSTRUCTION):

- PROVIDE ONE TRAVEL LANES IN EACH DIRECTION WITH 11' WIDTH
- PLACE DRUMS OR TYPE II BARRICADES TO PROTECT TRAFFIC FROM THE CONSTRUCTION ZONE
- CONSTRUCT PROPOSED DRAINAGE ALONG THE WEST SIDE OF LAKE AVENUE
- CONSTRUCT THE WIDENING ON THE WEST SIDE OF LAKE AVENUE PRIOR TO LAKE AVENUE RESURFACING AND PROFILE ADJUSTMENT
- CONSTRUCT TRAFFIC SIGNAL AND CURB AND GUTTER ON THE WEST SIDE OF LAKE AVENUE
- CONSTRUCT FINAL GRADING AND INSTALL TEMPORARY SEEDING OR PERMANENT LANDSCAPING ON THE WEST SIDE OF LAKE AVENUE

NOTE: THESE ARE SUGGESTED STAGING TYPICAL SECTIONS

LEGEND:

- (A) TEMPORARY PAVEMENT MARKING, TAPE TYPE IV 4" SOLID DOUBLE YELLOW @ 11" C-C
- (B) TEMPORARY PAVEMENT MARKING, TAPE TYPE IV 4" SOLID WHITE EDGE LINE
- WORK ZONE
- DRUMS OR TY II BARRICADE AT 50 FT SPACING DEVICES IN TAPER (20 FT C-C) DEVICES IN CURVES & RADII (25 FT C-C)

NOTES:

TRAFFIC ALONG IL 173 AND N LAKE AVE, SHALL BE MAINTAINED DURING THE WIDENING AND RESURFACING OPERATIONS BY STAGING THE CONSTRUCTION.

THE CONTRACTOR SHALL BACKFILL ALL LOCATIONS WHERE THERE IS NO TCB WALL AND THE DROP OFF ≥ 18" WITHIN 8" OF THE EDGE OF PAVEMENT.

MODEL: D:\info\... FILE NAME: ... PROJECT: P171909\CD\DATA\Description\171909-rt-staging.dgn

USER NAME = kalm	DESIGNED -	REVISED -
PLOT SCALE = 100,0000' / in.	CHECKED -	REVISED -
PLOT DATE = 1/27/2021	DATE -	REVISED -

**STATE OF ILLINOIS
DEPARTMENT OF TRANSPORTATION**

**IL 173 AT NORTH LAKE AVE.
STAGE II TYPICAL SECTIONS**

SCALE: SHEET 2 OF 2 SHEETS STA. TO STA.

F.A.P. RTE.	SECTION	COUNTY	TOTAL SHEETS	SHEET NO.
303	(134&134X)N	LAKE	129	36
CONTRACT NO. 60V39				
ILLINOIS FED. AID PROJECT				

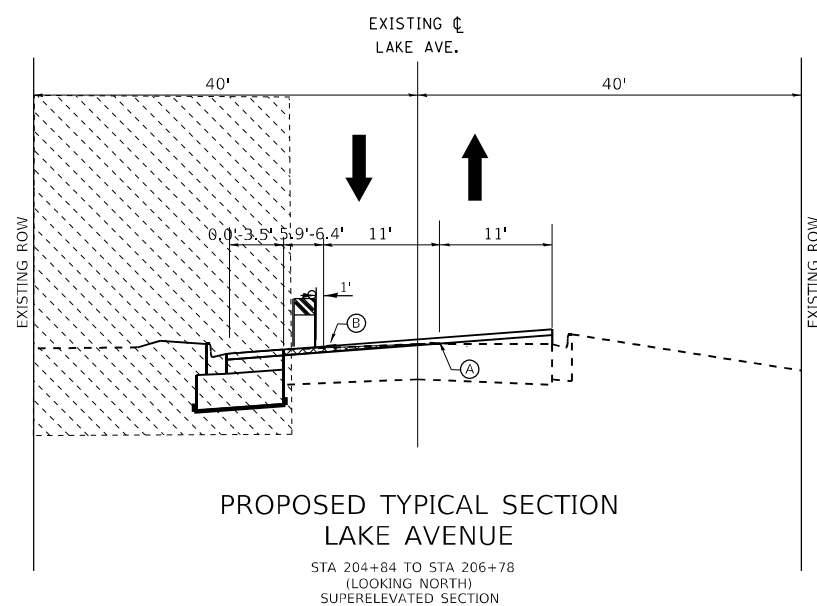
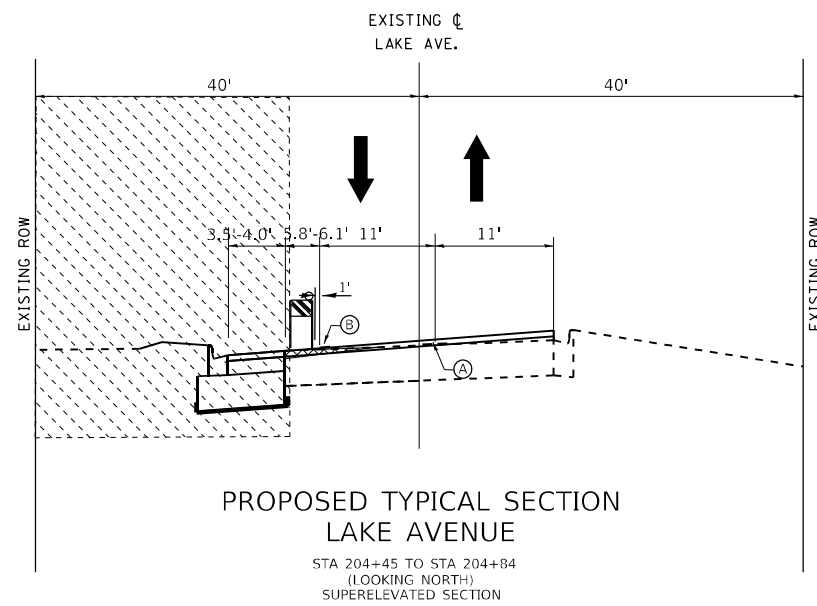
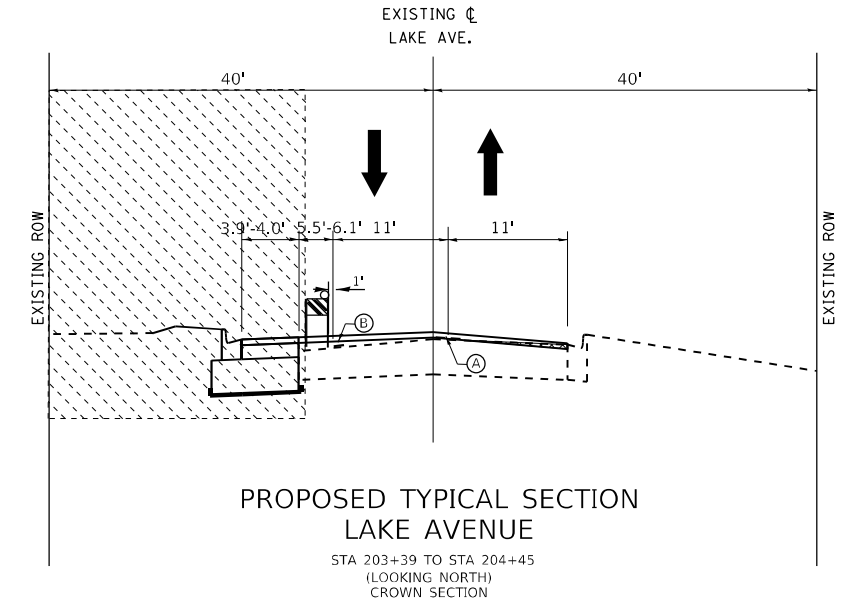
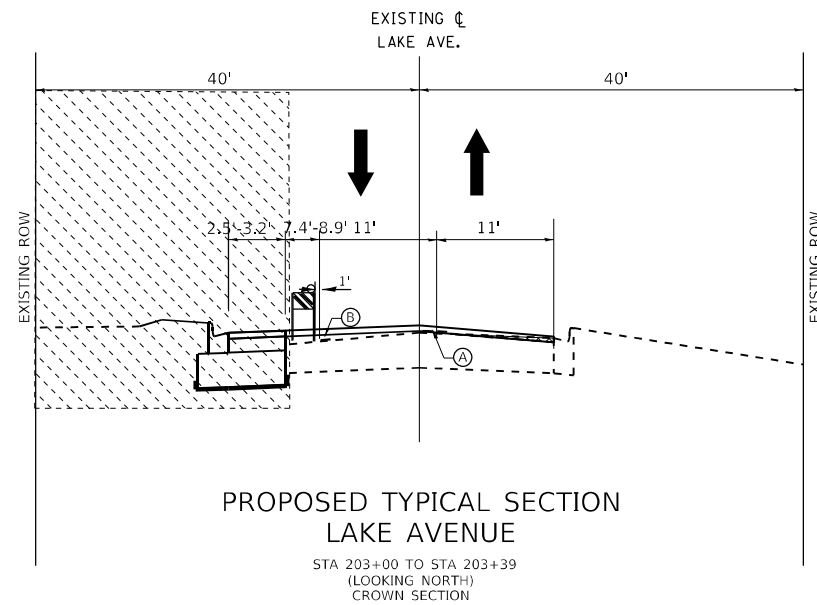
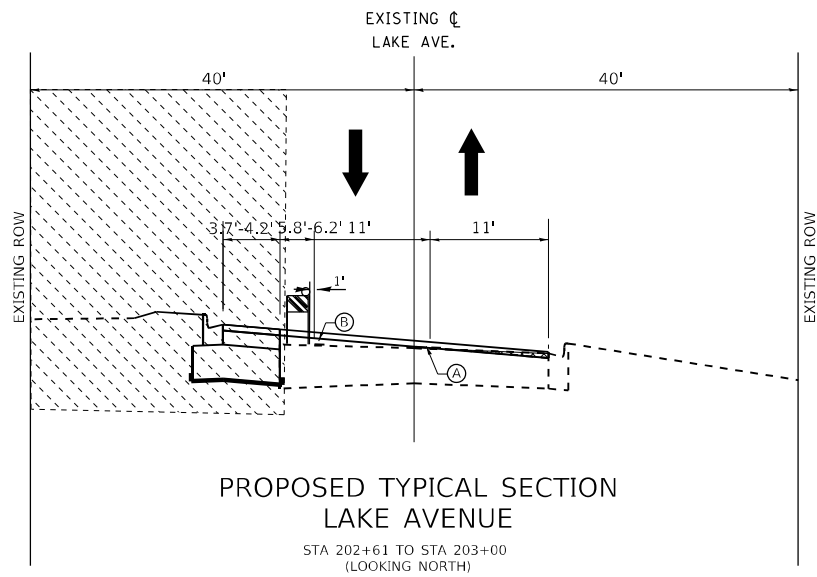

LEGEND:

- (A) TEMPORARY PAVEMENT MARKING, TAPE TYPE IV
4" SOLID DOUBLE YELLOW @ 11" C-C
- (B) TEMPORARY PAVEMENT MARKING, TAPE TYPE IV
4" SOLID WHITE EDGE LINE
- WORK ZONE
- DRUMS OR TY II BARRICADE AT 50 FT SPACING
DEVICES IN TAPER (20 FT C-C)
DEVICES IN CURVES & RADII (25 FT C-C)

NOTES:

TRAFFIC ALONG IL 173 AND N LAKE AVE, SHALL BE MAINTAINED DURING THE WIDENING AND RESURFACING OPERATIONS BY STAGING THE CONSTRUCTION.

THE CONTRACTOR SHALL BACKFILL ALL LOCATIONS WHERE THERE IS NO TCB WALL AND THE DROP OFF ≥ 18" WITHIN 8' OF THE EDGE OF PAVEMENT.

STAGE 2 (WEST SIDE CONSTRUCTION):

- PROVIDE ONE TRAVEL LANES IN EACH DIRECTION WITH 11' WIDTH
- PLACE DRUMS OR TYPE II BARRICADES TO PROTECT TRAFFIC FROM THE CONSTRUCTION ZONE
- CONSTRUCT PROPOSED DRAINAGE ALONG THE WEST SIDE OF LAKE AVENUE
- CONSTRUCT THE WIDENING ON THE WEST SIDE OF LAKE AVENUE PRIOR TO LAKE AVENUE RESURFACING AND PROFILE ADJUSTMENT
- CONSTRUCT TRAFFIC SIGNAL AND CURB AND GUTTER ON THE WEST SIDE OF LAKE AVENUE
- CONSTRUCT FINAL GRADING AND INSTALL TEMPORARY SEEDING OR PERMANENT LANDSCAPING ON THE WEST SIDE OF LAKE AVENUE

NOTE: THESE ARE SUGGESTED STAGING TYPICAL SECTIONS

MODEL: Default
 FILE NAME: p:\data\m3000.dwg
 PROJECT: I:\projects\171909\171909\CADD\data\Design\171909-01-01.dwg

USER NAME = kalorm	DESIGNED -	REVISED -
PLOT SCALE = 100,0000' / in.	CHECKED -	REVISED -
PLOT DATE = 1/27/2021	DATE -	REVISED -

**STATE OF ILLINOIS
DEPARTMENT OF TRANSPORTATION**

IL 173 AT NORTH LAKE AVE. STAGE II TYPICAL SECTIONS	
SCALE:	SHEET 2 OF 2 SHEETS STA. TO STA.

F.A.P. RTE.	SECTION	COUNTY	TOTAL SHEETS	SHEET NO.
303	(134&134X)N	LAKE	129	37
CONTRACT NO. 60V39				
ILLINOIS FED. AID PROJECT				

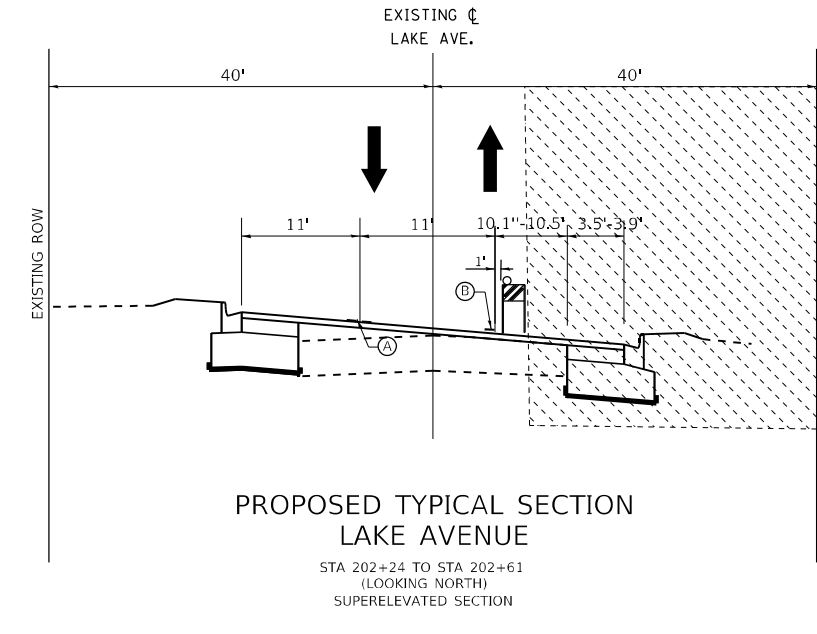
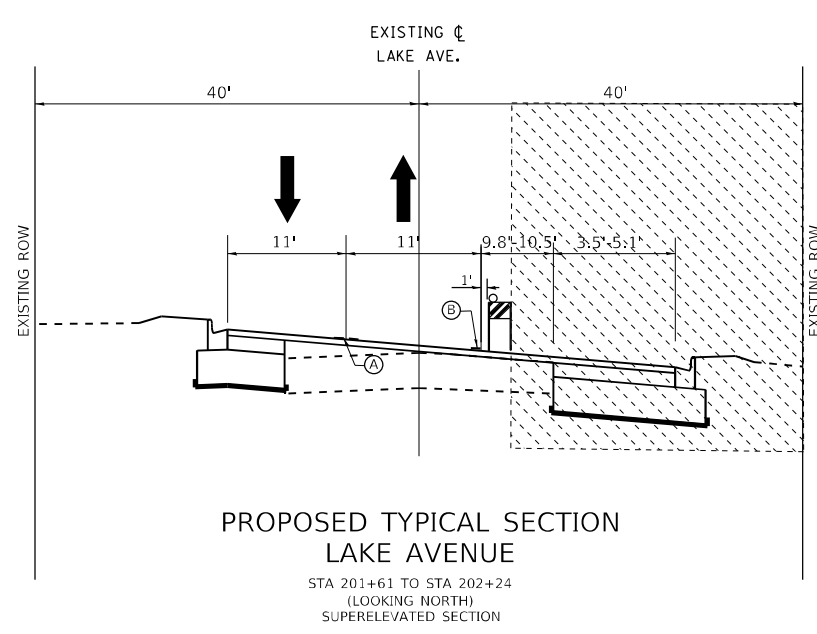
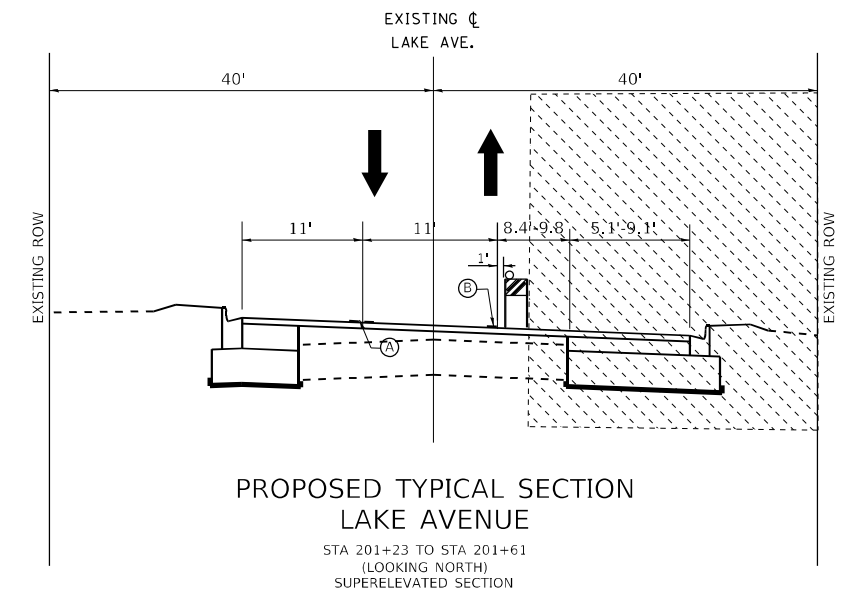
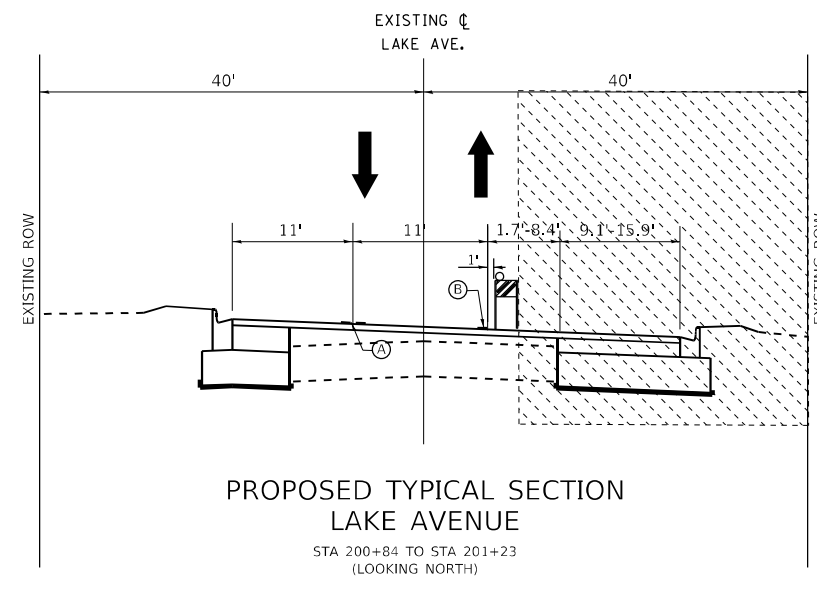
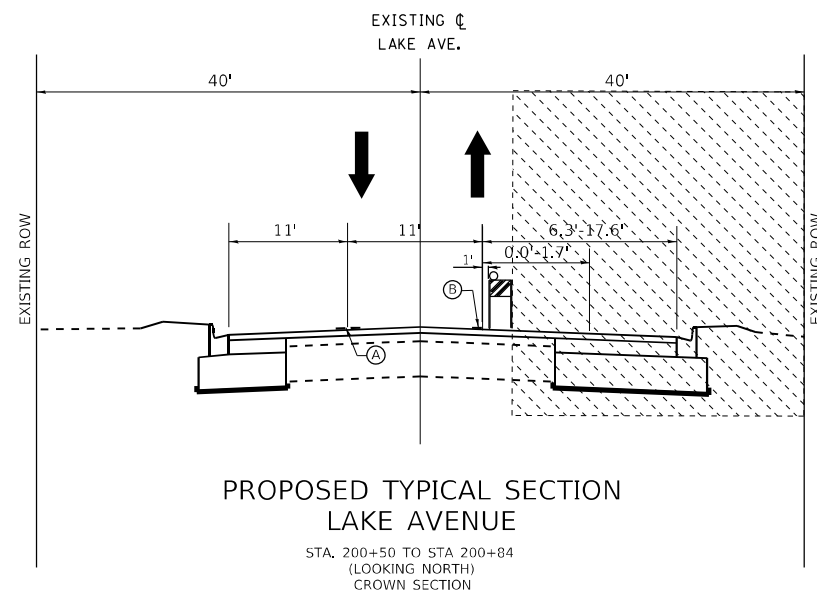

STAGE 3 (EAST SIDE CONSTRUCTION):

- PROVIDE ONE TRAVEL LANES IN EACH DIRECTION WITH 11' WIDTH
- PLACE DRUMS OR TYPE II BARRICADES TO PROTECT TRAFFIC FROM THE CONSTRUCTION ZONE
- CONSTRUCT PROPOSED DRAINAGE ALONG THE EAST SIDE OF IL 173 LAKE AVENUE
- CONSTRUCT TRAFFIC SIGNAL AND CURB AND GUTTER ON THE EAST SIDE OF LAKE AVENUE
- CONSTRUCT FINAL GRADING AND INSTALL TEMPORARY SEEDING OR PERMANENT LANDSCAPING ON THE EAST SIDE OF LAKE AVENUE
- RESURFACING OF IL 173

NOTE: THESE ARE SUGGESTED STAGING TYPICAL SECTIONS

LEGEND:

- (A) TEMPORARY PAVEMENT MARKING, TAPE TYPE IV 4" SOLID DOUBLE YELLOW @ 11" C-C
- (B) TEMPORARY PAVEMENT MARKING, TAPE TYPE IV 4" SOLID WHITE EDGE LINE
- WORK ZONE
- DRUMS OR TY II BARRICADE AT 50 FT SPACING DEVICES IN TAPER (20 FT C-C) DEVICES IN CURVES & RADII (25 FT C-C)

NOTES:

TRAFFIC ALONG IL 173 AND N LAKE AVE. SHALL BE MAINTAINED DURING THE WIDENING AND RESURFACING OPERATIONS BY STAGING THE CONSTRUCTION.

THE CONTRACTOR SHALL BACKFILL ALL LOCATIONS WHERE THERE IS NO TCB WALL AND THE DROP OFF \geq 18" WITHIN 8' OF THE EDGE OF PAVEMENT.

MODEL: Default
FILE NAME: p:\data\m3000.dwg
PROJECT: P171099\CD\DATA\Design\171099-01-01.dwg

USER NAME = kalorm	DESIGNED -	REVISED -
DRAWN -	REVISIONS -	
PLOT SCALE = 100,0000' / in.	CHECKED -	REVISED -
PLOT DATE = 1/27/2021	DATE -	REVISED -

**STATE OF ILLINOIS
DEPARTMENT OF TRANSPORTATION**

**IL 173 AT NORTH LAKE AVE.
STAGE III TYPICAL SECTIONS**

SCALE: SHEET 2 OF 2 SHEETS STA. TO STA.

F.A.P. RTE.	SECTION	COUNTY	TOTAL SHEETS	SHEET NO.
303	(134&134X)N	LAKE	129	38
CONTRACT NO. 60V39				
ILLINOIS FED. AID PROJECT				

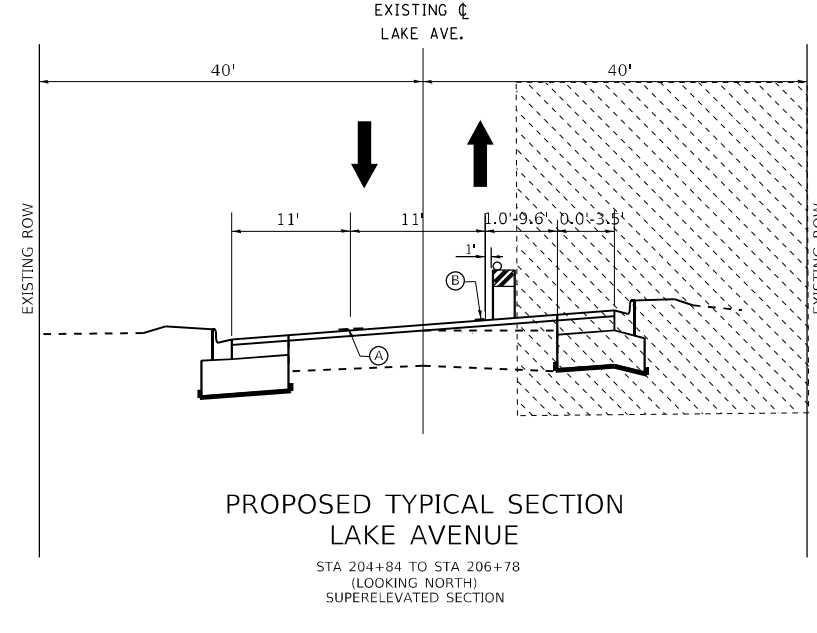
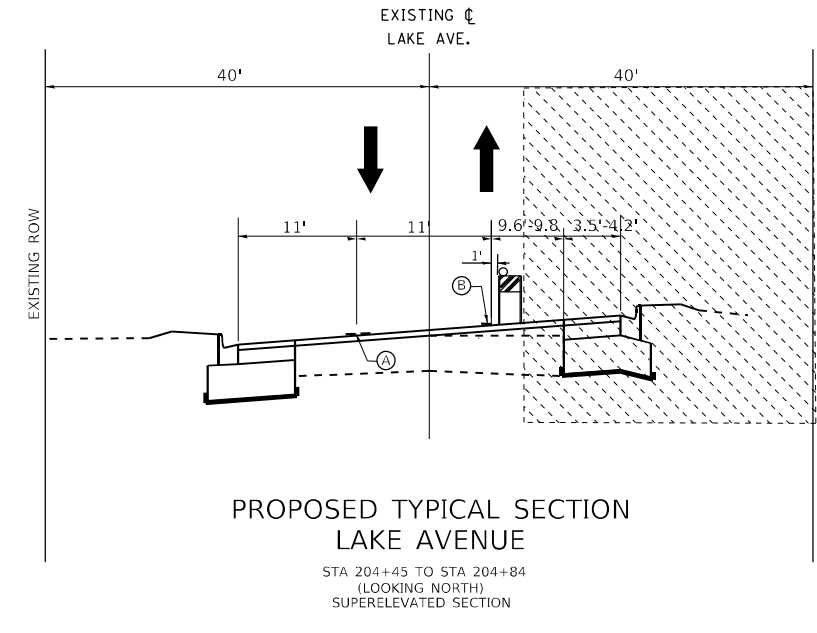
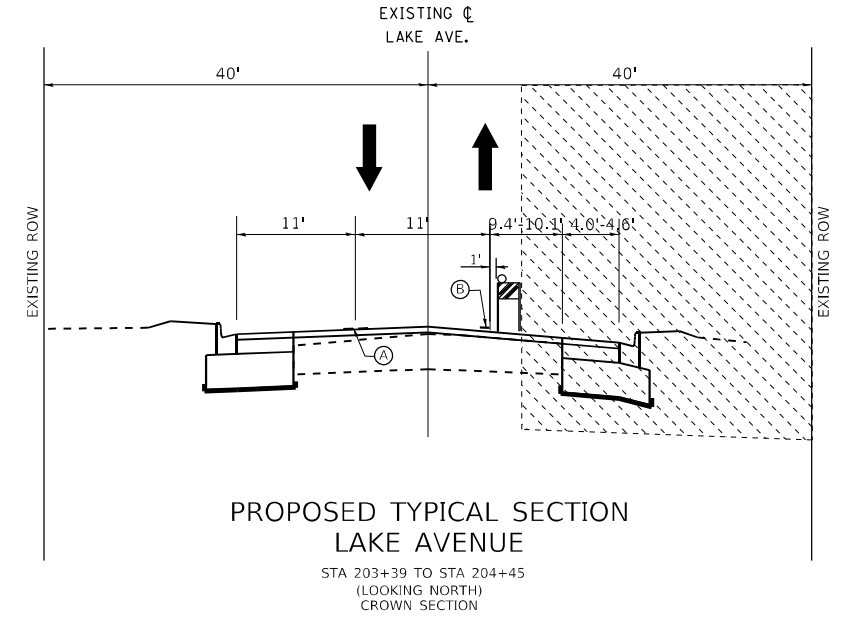
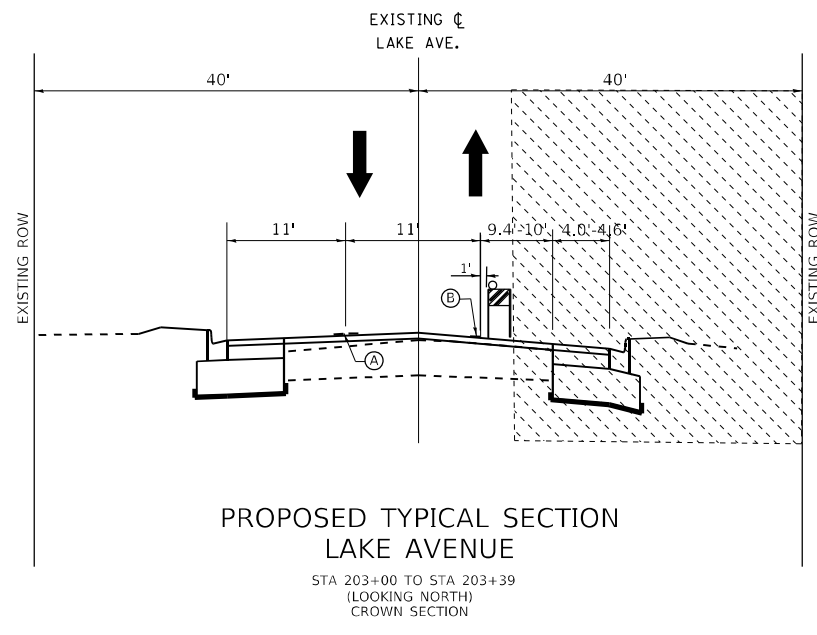
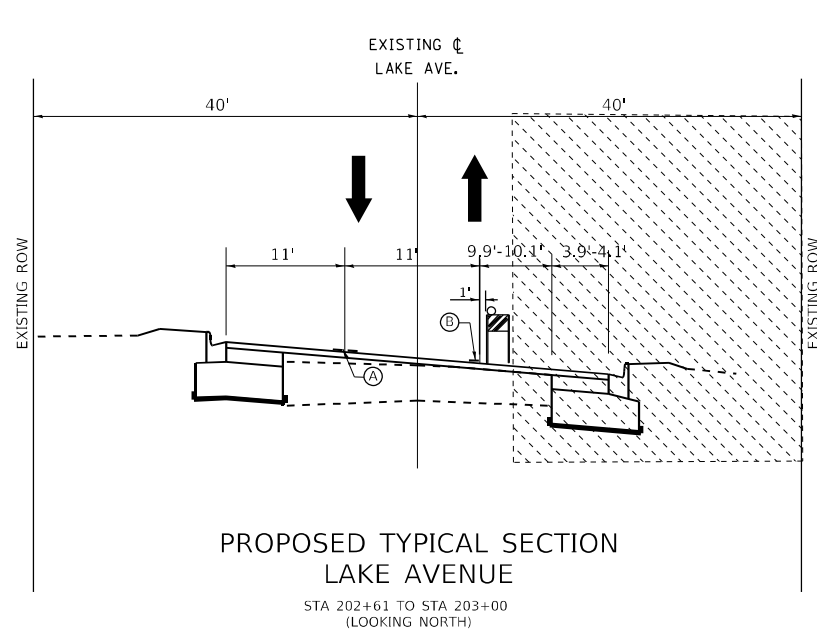

STAGE 3 (EAST SIDE CONSTRUCTION):

- PROVIDE ONE TRAVEL LANES IN EACH DIRECTION WITH 11' WIDTH
- PLACE DRUMS OR TYPE II BARRICADES TO PROTECT TRAFFIC FROM THE CONSTRUCTION ZONE
- CONSTRUCT PROPOSED DRAINAGE ALONG THE EAST SIDE OF IL 173 LAKE AVENUE
- CONSTRUCT TRAFFIC SIGNAL AND CURB AND GUTTER ON THE EAST SIDE OF LAKE AVENUE
- CONSTRUCT FINAL GRADING AND INSTALL TEMPORARY SEEDING OR PERMANENT LANDSCAPING ON THE EAST SIDE OF LAKE AVENUE
- RESURFACING OF IL 173

NOTE: THESE ARE SUGGESTED STAGING TYPICAL SECTIONS

LEGEND:

- (A) TEMPORARY PAVEMENT MARKING, TAPE TYPE IV 4" SOLID DOUBLE YELLOW @ 11" C-C
- (B) TEMPORARY PAVEMENT MARKING, TAPE TYPE IV 4" SOLID WHITE EDGE LINE
- WORK ZONE
- DRUMS OR TY II BARRICADE AT 50 FT SPACING DEVICES IN TAPER (20 FT C-C) DEVICES IN CURVES & RADII (25 FT C-C)

NOTES:

TRAFFIC ALONG IL 173 AND N LAKE AVE. SHALL BE MAINTAINED DURING THE WIDENING AND RESURFACING OPERATIONS BY STAGING THE CONSTRUCTION.

THE CONTRACTOR SHALL BACKFILL ALL LOCATIONS WHERE THERE IS NO TCB WALL AND THE DROP OFF \geq 18" WITHIN 8' OF THE EDGE OF PAVEMENT.

MODEL: Default
FILE NAME: p:\work\11346\11346.dwg
PROJECT: I173099\11346\11346.dwg
OFFICE: DISTRICT 1 PROJECT: I173099\11346\11346.dwg

USER NAME = kalorm	DESIGNED -	REVISED -
PLOT SCALE = 100,0000' / in.	DRAWN -	REVISED -
PLOT DATE = 1/27/2021	CHECKED -	REVISED -
	DATE -	REVISED -

**STATE OF ILLINOIS
DEPARTMENT OF TRANSPORTATION**

**IL 173 AT NORTH LAKE AVE.
STAGE III TYPICAL SECTIONS**

SCALE: SHEET 2 OF 2 SHEETS STA. TO STA.

F.A.P. RTE.	SECTION	COUNTY	TOTAL SHEETS	SHEET NO.
303	(134&134X)N	LAKE	129	39
CONTRACT NO. 60V39				
ILLINOIS FED. AID PROJECT				

MODEL: Default
 FILE NAME: p:\data\mtrnroom.dwt\illinois.gov\PIWDOT\Documents\DOT_Offices\Dist\refc_1\Project\PI171909\CAD\DATA\Design\171909_mtr.ctb\p171909.dgn

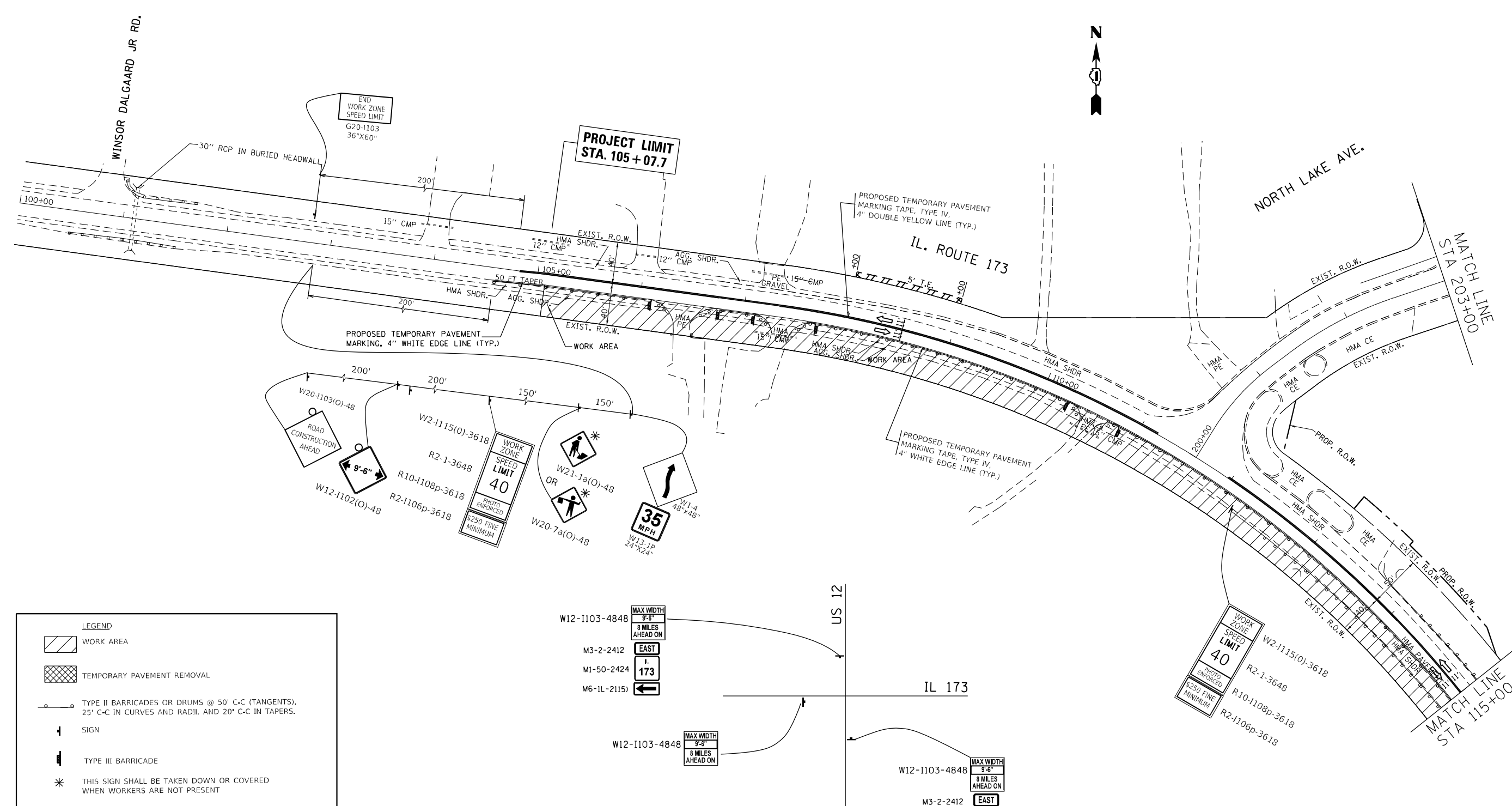

NOTE: THIS IS SUGGESTED STAGING PLAN

LEGEND

- WORK AREA
- TEMPORARY PAVEMENT REMOVAL
- TYPE II BARRICADES OR DRUMS @ 50' C-C (TANGENTS), 25' C-C IN CURVES AND RADII, AND 20' C-C IN TAPERS.
- SIGN
- TYPE III BARRICADE
- THIS SIGN SHALL BE TAKEN DOWN OR COVERED WHEN WORKERS ARE NOT PRESENT

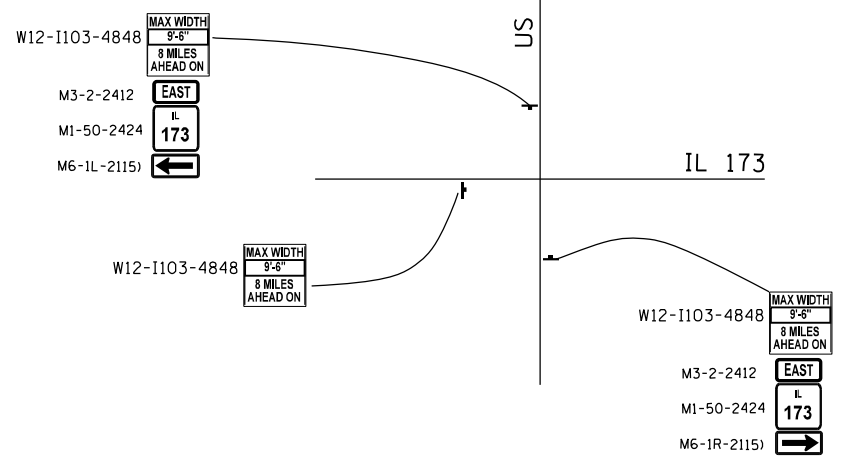

USER NAME = kalorm	DESIGNED -	REVISED - RK - 3/15/2021
	DRAWN -	REVISED -
PLOT SCALE = 100,0000' / in.	CHECKED -	REVISED -
PLOT DATE = 3/14/2021	DATE -	REVISED -

**STATE OF ILLINOIS
 DEPARTMENT OF TRANSPORTATION**

IL 173 AT NORTH LAKE AVE. MAINTENANCE OF TRAFFIC (STAGE 1)	
SCALE:	SHEET 1 OF 8 SHEETS STA. TO STA.

F.A.P. RTE.	SECTION	COUNTY	TOTAL SHEETS	SHEET NO.
303	(134&134X)N	LAKE	129	40
CONTRACT NO. 60V39				
ILLINOIS FED. AID PROJECT				

MODEL: Default
 FILE NAME: p:\data\room\dot\illinois\dot\pww\dot\Documents\DOT_Offices\Distric_1\Project\171909\CADD\DATA\Design\171909-att-ctc-ajma.dgn

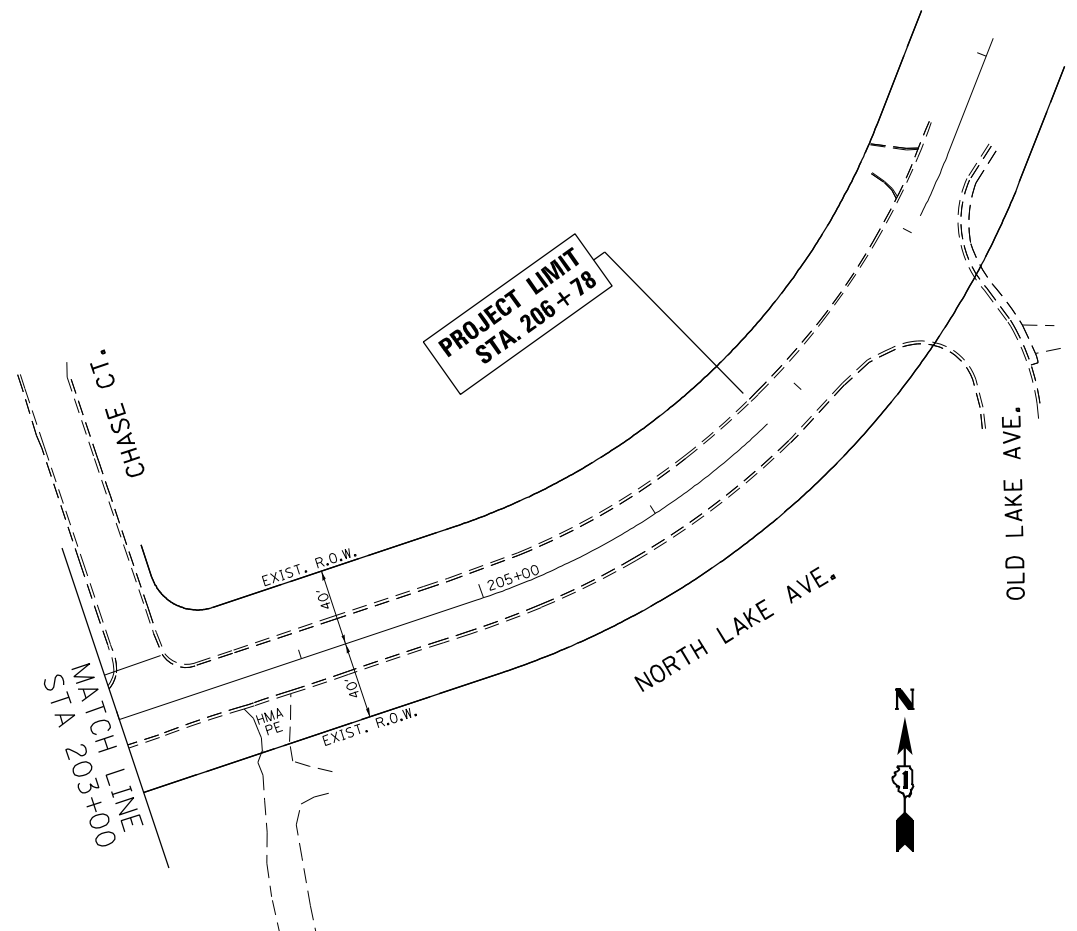
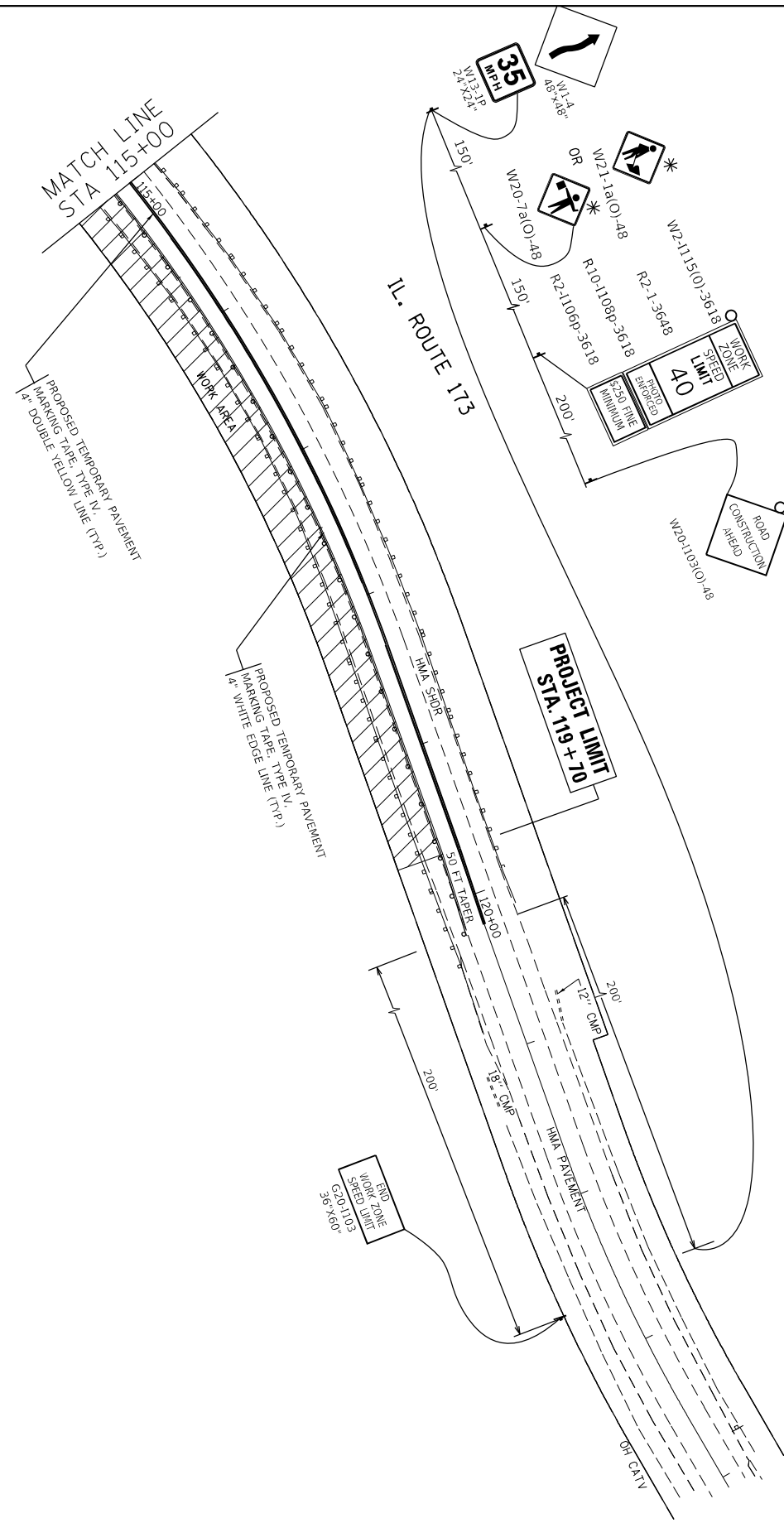

LEGEND

- WORK AREA
- TEMPORARY PAVEMENT REMOVAL
- TYPE II BARRICADES OR DRUMS @ 50' C-C (TANGENTS), 25' C-C IN CURVES AND RADII, AND 20' C-C IN TAPERS.
- SIGN
- TYPE III BARRICADE
- THIS SIGN SHALL BE TAKEN DOWN OR COVERED WHEN WORKERS ARE NOT PRESENT

NOTE: THIS IS SUGGESTED STAGING PLAN

USER NAME = kalorm	DESIGNED -	REVISED -	RK - 3/15/2021
	DRAWN -	REVISED -	
PLOT SCALE = 100,0000' / in.	CHECKED -	REVISED -	
PLOT DATE = 3/14/2021	DATE -	REVISED -	

**STATE OF ILLINOIS
 DEPARTMENT OF TRANSPORTATION**

**IL 173 AT NORTH LAKE AVE.
 MAINTENANCE OF TRAFFIC (STAGE 1)**

SCALE: SHEET 2 OF 8 SHEETS STA. TO STA.

F.A.P. RTE.	SECTION	COUNTY	TOTAL SHEETS	SHEET NO.
303	(134&134X)N	LAKE	129	41
CONTRACT NO. 60V39				
ILLINOIS FED. AID PROJECT				

MODEL: Default
 FILE NAME: p:\data\m3000.dwg
 PROJECT: P171099\CADD\DATA\Design\171099-01-01.dwg
 PROJECT: P171099\CADD\DATA\Design\171099-01-01.dwg

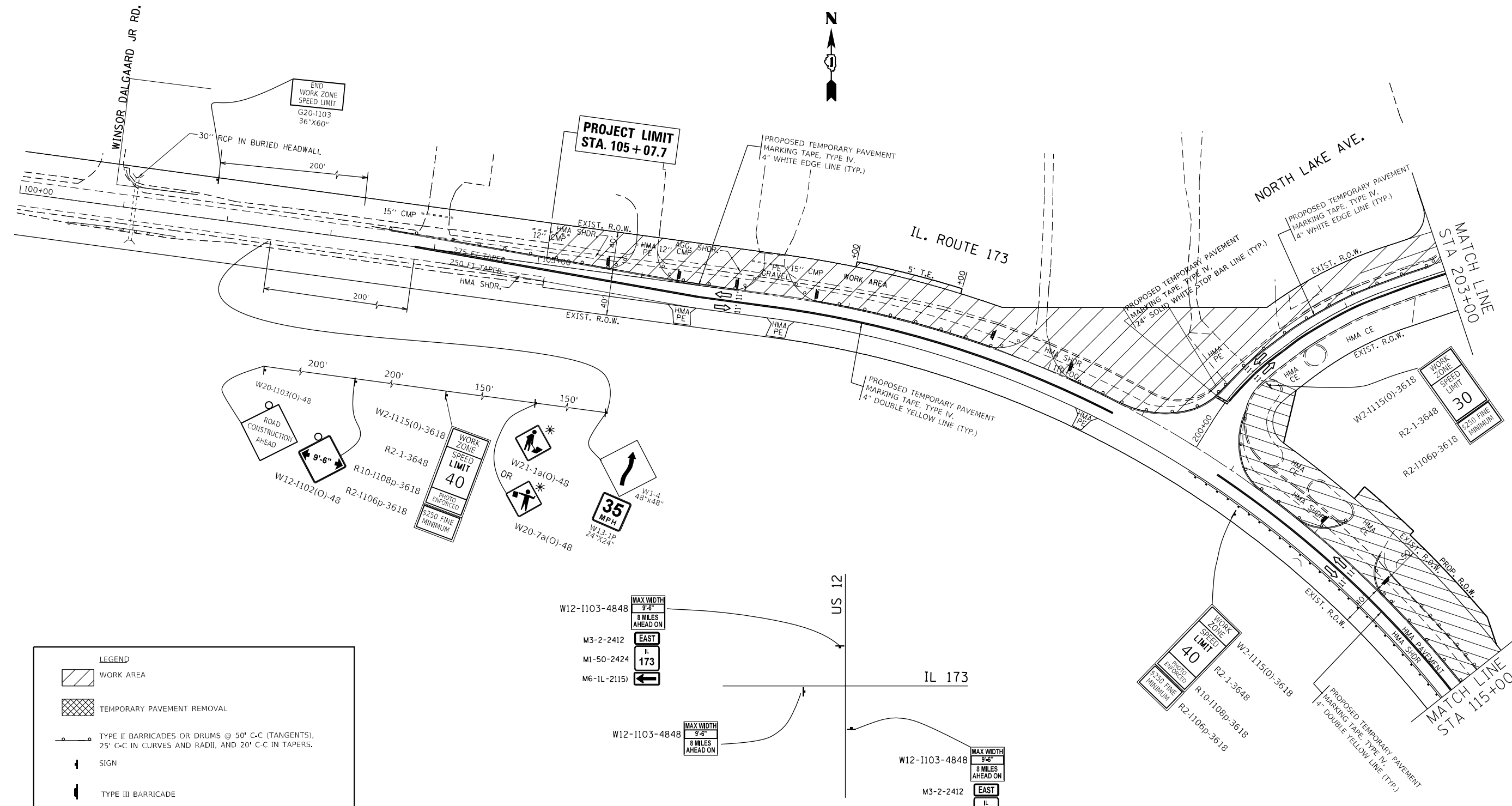

LEGEND

- WORK AREA
- TEMPORARY PAVEMENT REMOVAL
- TYPE II BARRICADES OR DRUMS @ 50' C-C (TANGENTS), 25' C-C IN CURVES AND RADII, AND 20' C-C IN TAPERS.
- SIGN
- TYPE III BARRICADE
- THIS SIGN SHALL BE TAKEN DOWN OR COVERED WHEN WORKERS ARE NOT PRESENT

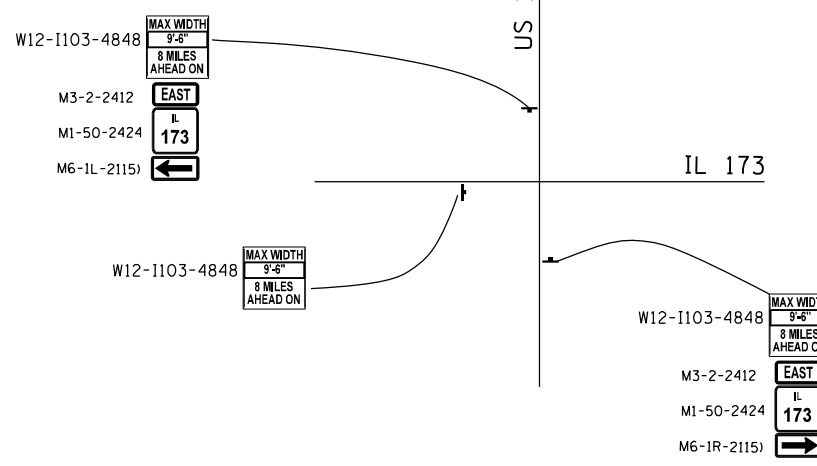

NOTE: THIS IS SUGGESTED STAGING PLAN

USER NAME = kalm	DESIGNED -	REVISED - RK - 3/15/2021
	DRAWN -	REVISED -
PLOT SCALE = 100,0000' / in.	CHECKED -	REVISED -
PLOT DATE = 3/14/2021	DATE -	REVISED -

**STATE OF ILLINOIS
DEPARTMENT OF TRANSPORTATION**

IL 173 AT NORTH LAKE AVE. MAINTENANCE OF TRAFFIC (STAGE 2)			
SCALE:	SHEET 3	OF 8 SHEETS	STA. TO STA.

F.A.P. RTE.	SECTION	COUNTY	TOTAL SHEETS	SHEET NO.
303	(134&134X)N	LAKE	129	42
CONTRACT NO. 60V39				
ILLINOIS FED. AID PROJECT				

MODEL: Default
 FILE NAME: p:\data\barroom.dwg
 PROJECT: P171099\CADD\DATA\Design\171099-att-cta\p171099-att-cta.dwg

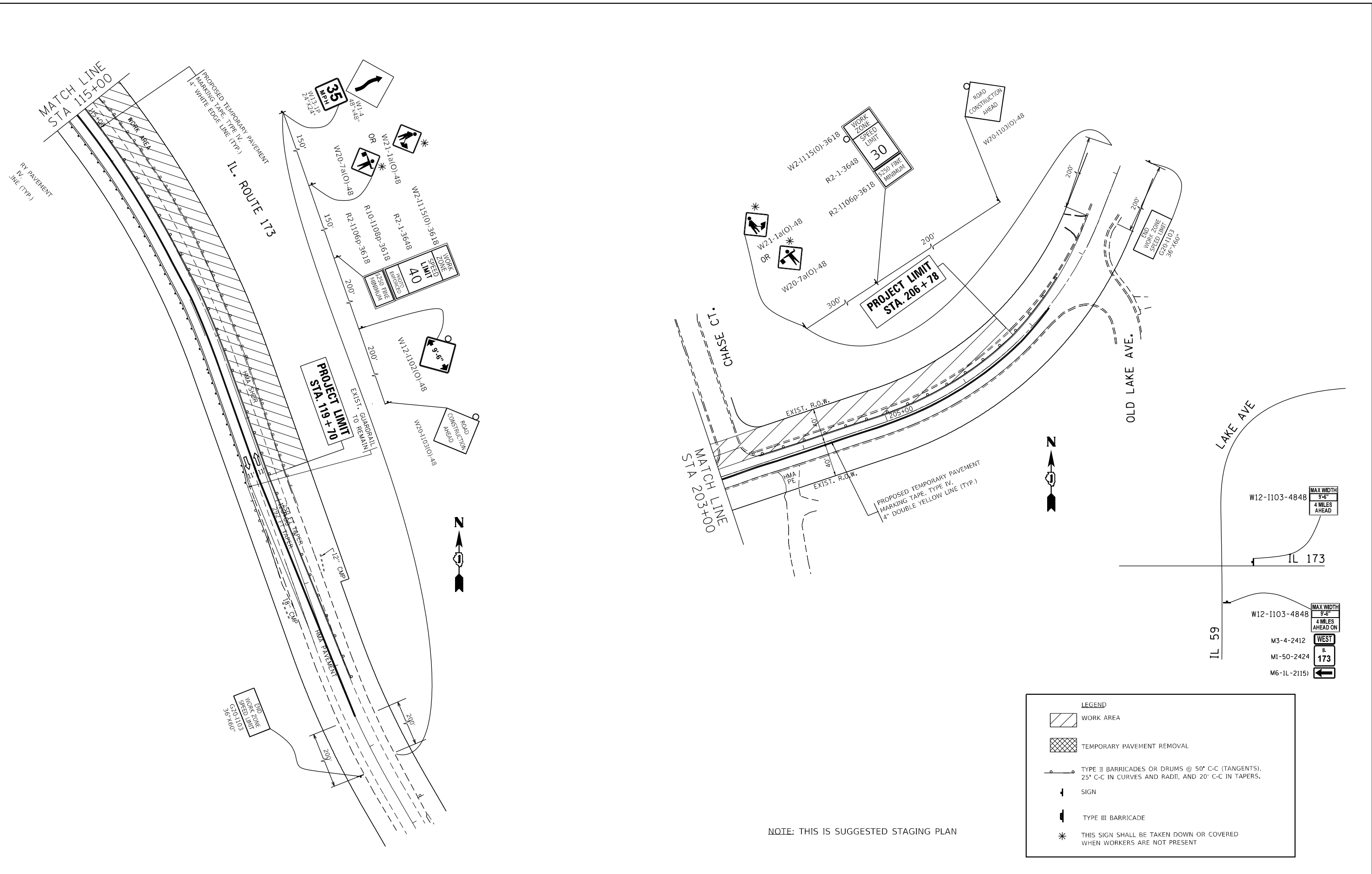

NOTE: THIS IS SUGGESTED STAGING PLAN

LEGEND

- WORK AREA
- TEMPORARY PAVEMENT REMOVAL
- TYPE II BARRICADES OR DRUMS @ 50' C-C (TANGENTS), 25' C-C IN CURVES AND RADII, AND 20' C-C IN TAPERS.
- SIGN
- TYPE III BARRICADE
- * THIS SIGN SHALL BE TAKEN DOWN OR COVERED WHEN WORKERS ARE NOT PRESENT

USER NAME = kalorm	DESIGNED -	REVISED -	RK - 3/15/2021
	DRAWN -	REVISED -	
PLOT SCALE = 100,0000' / in.	CHECKED -	REVISED -	
PLOT DATE = 3/14/2021	DATE -	REVISED -	

**STATE OF ILLINOIS
 DEPARTMENT OF TRANSPORTATION**

**IL 173 AT NORTH LAKE AVE.
 MAINTENANCE OF TRAFFIC (STAGE 2)**

SCALE: SHEET 4 OF 8 SHEETS STA. TO STA.

F.A.P. RTE. 303	SECTION (134&134X)N	COUNTY LAKE	TOTAL SHEETS 129	SHEET NO. 43
CONTRACT NO. 60V39				
ILLINOIS FED. AID PROJECT				

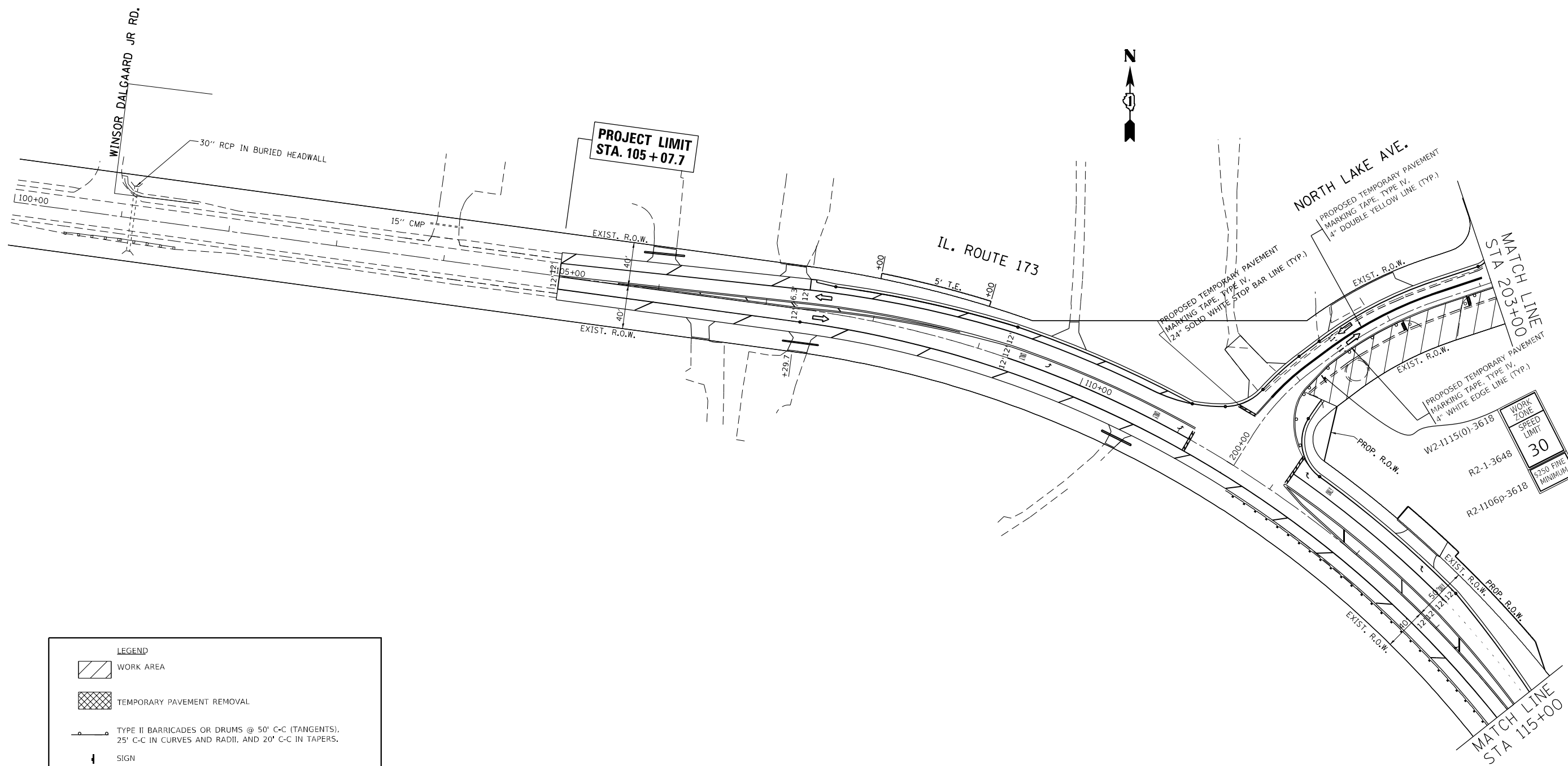

LEGEND	
	WORK AREA
	TEMPORARY PAVEMENT REMOVAL
	TYPE II BARRICADES OR DRUMS @ 50' C-C (TANGENTS), 25' C-C IN CURVES AND RADII, AND 20' C-C IN TAPERS.
	SIGN
	TYPE III BARRICADE
	THIS SIGN SHALL BE TAKEN DOWN OR COVERED WHEN WORKERS ARE NOT PRESENT

NOTE: THIS IS SUGGESTED STAGING PLAN

MODEL: Default
 FILE NAME: p:\data\m300m.dwg
 PROJECT: P171909\CD\DATA\Design\171909-att-cta\plan.dwg

USER NAME = kalorm	DESIGNED -	REVISED - RK - 3/15/2021
PLOT SCALE = 100,0000' / in.	DRAWN -	REVISED -
PLOT DATE = 3/14/2021	CHECKED -	REVISED -
	DATE -	REVISED -

**STATE OF ILLINOIS
DEPARTMENT OF TRANSPORTATION**

**IL 173 AT NORTH LAKE AVE.
MAINTENANCE OF TRAFFIC (STAGE 3)**

SCALE: SHEET 5 OF 8 SHEETS STA. TO STA.

F.A.P. RTE. 303	SECTION (134&134X)N	COUNTY LAKE	TOTAL SHEETS 129	SHEET NO. 44
CONTRACT NO. 60V39				
ILLINOIS FED. AID PROJECT				

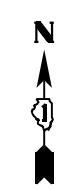
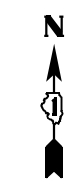
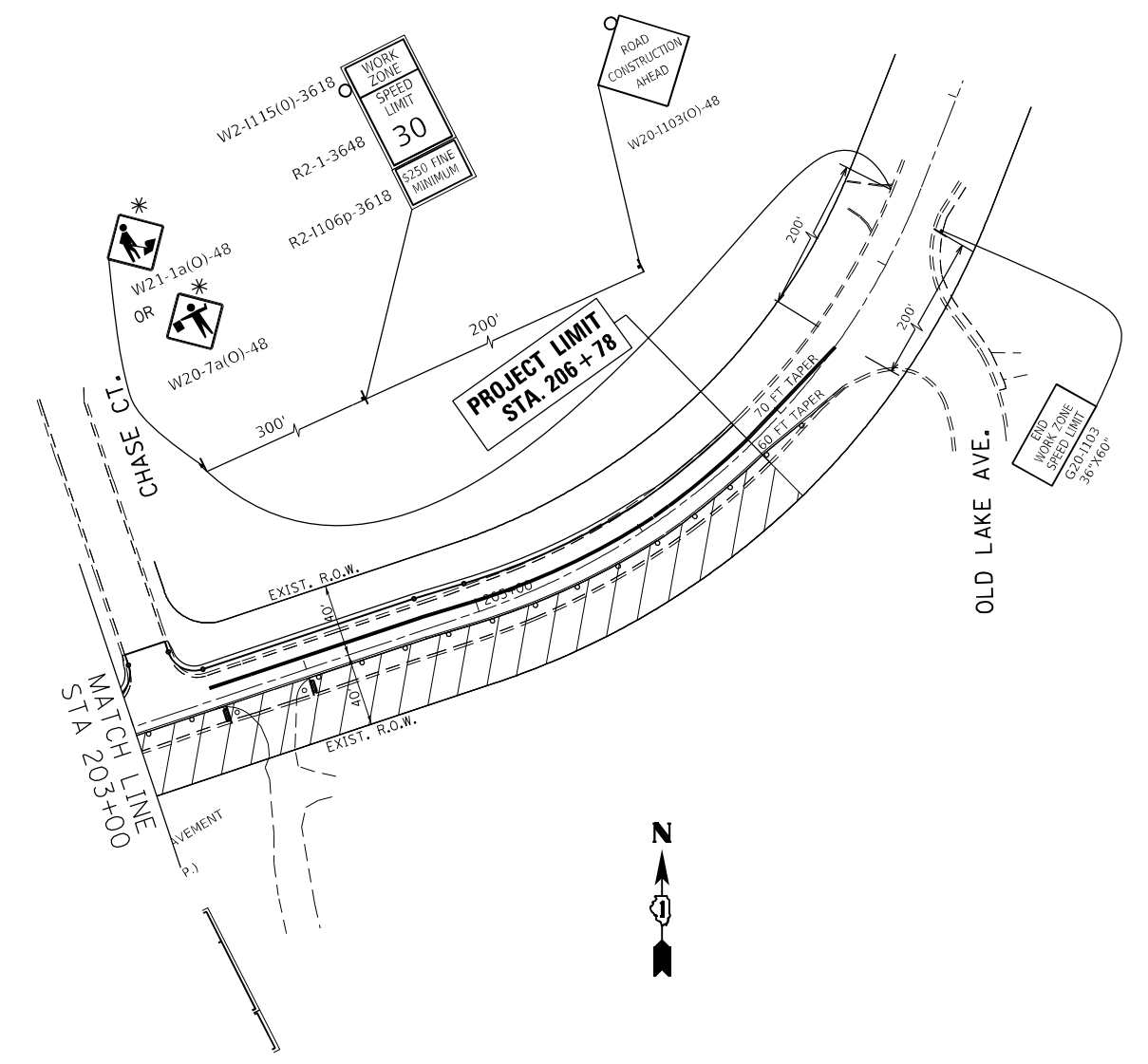
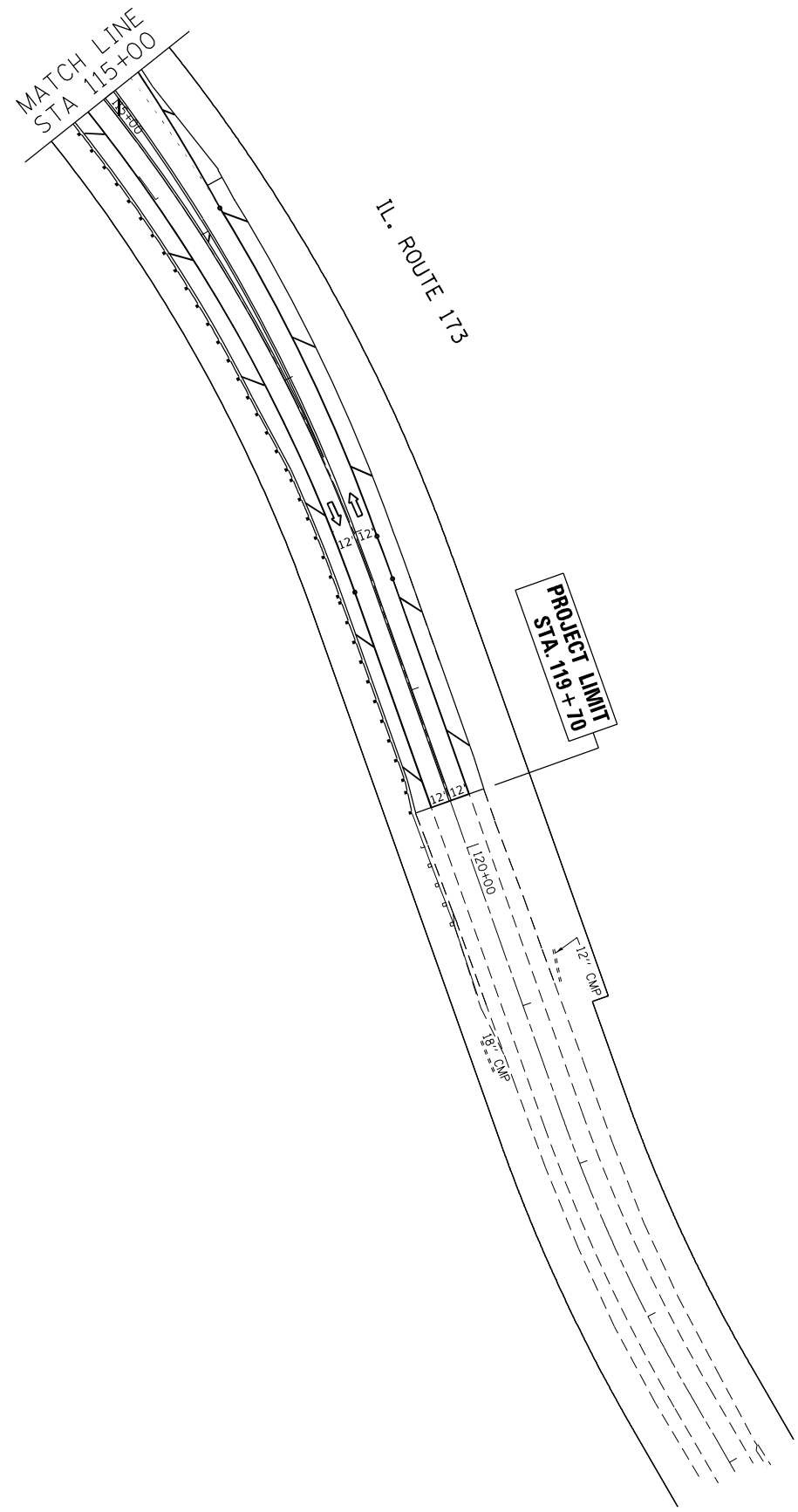

NOTE: THIS IS SUGGESTED STAGING PLAN

LEGEND	
	WORK AREA
	TEMPORARY PAVEMENT REMOVAL
	TYPE II BARRICADES OR DRUMS @ 50' C-C (TANGENTS), 25' C-C IN CURVES AND RADII, AND 20' C-C IN TAPERS.
	SIGN
	TYPE III BARRICADE
	THIS SIGN SHALL BE TAKEN DOWN OR COVERED WHEN WORKERS ARE NOT PRESENT

MODEL: Default
 FILE NAME: p:\data\m300m.dwg
 PROJECT: P:\171909\CAD\DATA\Design\171909-att-cta\plan.dwg

USER NAME = kalorm	DESIGNED -	REVISED - RK - 3/15/2021
PLOT SCALE = 100,0000' / in.	DRAWN -	REVISED -
PLOT DATE = 3/14/2021	CHECKED -	REVISED -
	DATE -	REVISED -

**STATE OF ILLINOIS
DEPARTMENT OF TRANSPORTATION**

**IL 173 AT NORTH LAKE AVE.
MAINTENANCE OF TRAFFIC (STAGE 3)**

SCALE: SHEET 6 OF 8 SHEETS STA. TO STA.

F.A.P. RTE. 303	SECTION (134&134X)N	COUNTY LAKE	TOTAL SHEETS 129	SHEET NO. 45
CONTRACT NO. 60V39				
ILLINOIS FED. AID PROJECT				

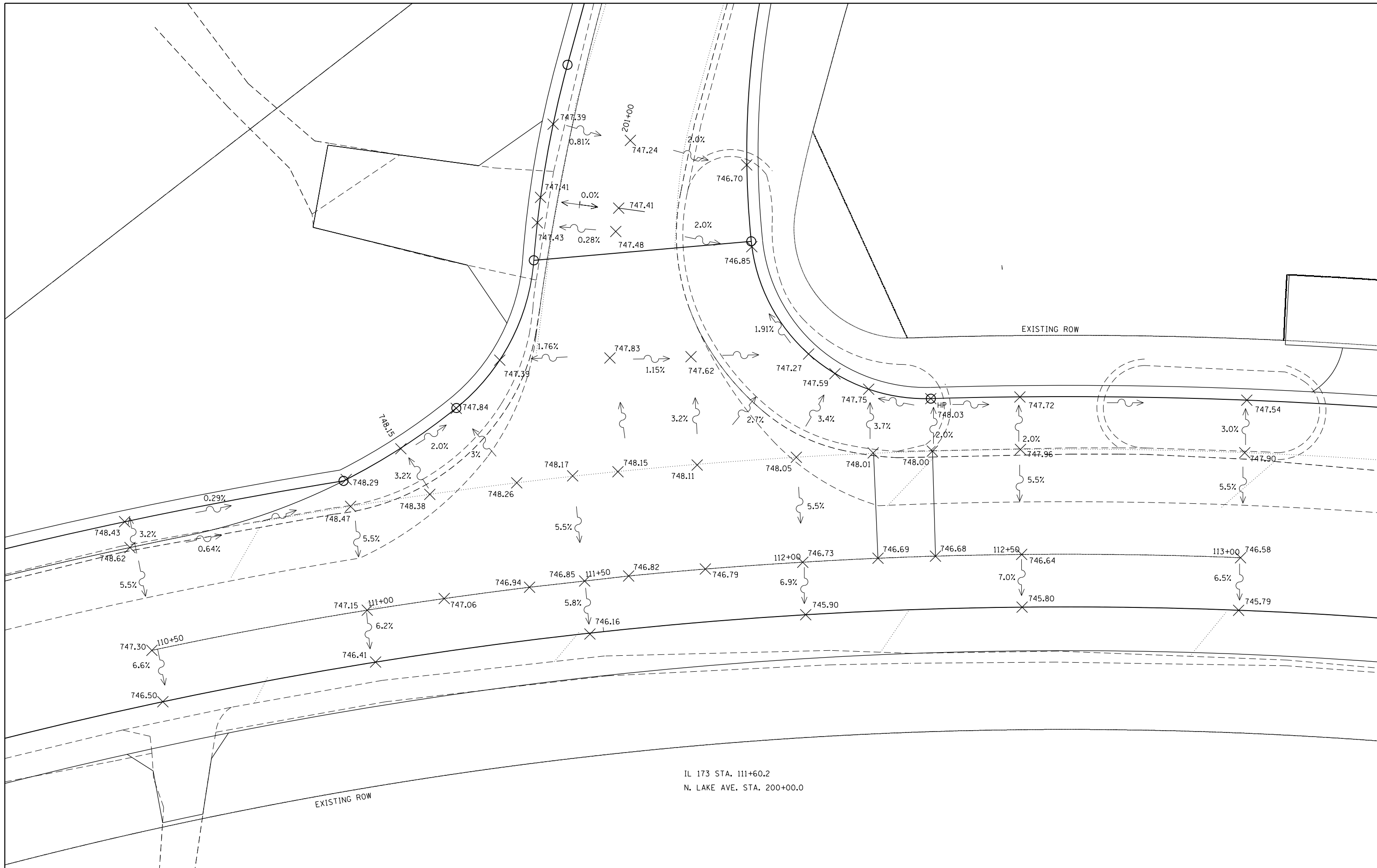

IL 173 STA. 111+60.2
 N. LAKE AVE. STA. 200+00.0

FILE NAME =	USER NAME = kalbrn	DESIGNED -	REVISED - RK - 3/15/2021
pw:\plnroom.dot\illinois.gov\PIDOT\Documents\IDOT Offices\District 1\Projects\P171909\Drawings\Design\P171909-sht-details.dgn		DRAWN -	REVISED -
	PLOT SCALE = 100.0000' / in.	CHECKED -	REVISED -
	PLOT DATE = 3/14/2021	DATE -	REVISED -

**STATE OF ILLINOIS
 DEPARTMENT OF TRANSPORTATION**

**INTERSECTION GRADING PLAN
 IL 173 & N. LAKE AVE.**

SCALE: 1" = 10' SHEET NO. OF SHEETS STA. TO STA.

F.A.P. RTE.	SECTION	COUNTY	TOTAL SHEETS	SHEET NO.
303	(134&134X)N	LAKE	129	46
CONTRACT NO. 60V39				
ILLINOIS FED. AID PROJECT				

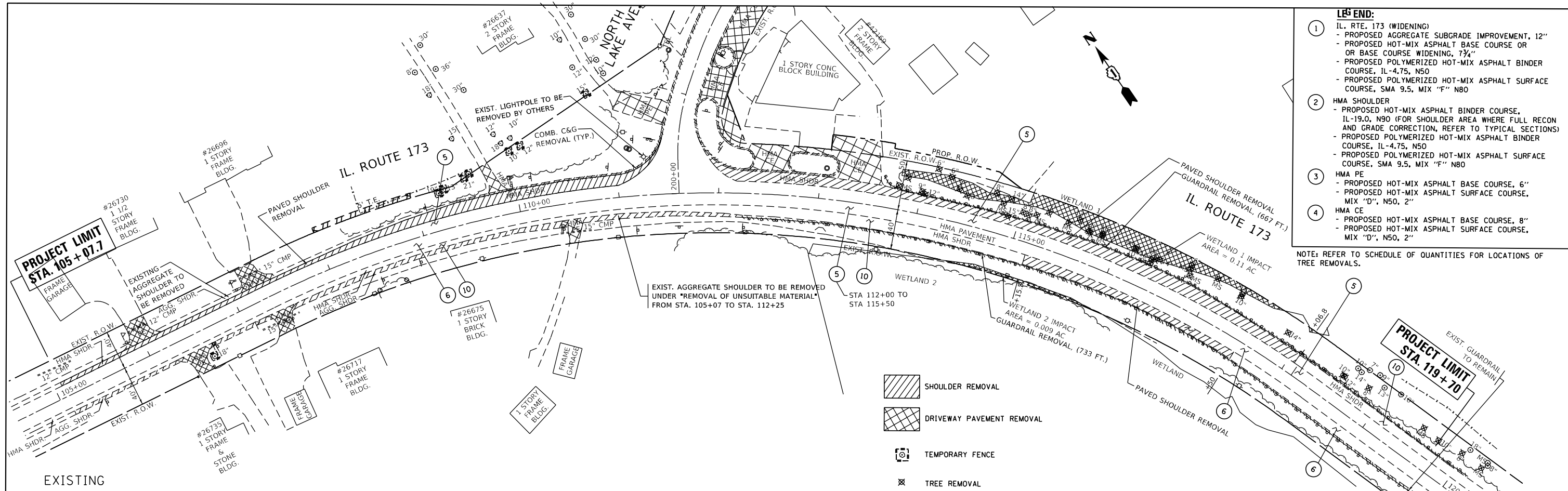

- LEGEND:**
- ① IL. RTE. 173 (WIDENING)
 - PROPOSED AGGREGATE SUBGRADE IMPROVEMENT, 12"
 - PROPOSED HOT-MIX ASPHALT BASE COURSE OR OR BASE COURSE WIDENING, 7 1/2"
 - PROPOSED POLYMERIZED HOT-MIX ASPHALT BINDER COURSE, IL-4.75, N50
 - PROPOSED POLYMERIZED HOT-MIX ASPHALT SURFACE COURSE, SMA 9.5, MIX "F" N80
 - ② HMA SHOULDER
 - PROPOSED HOT-MIX ASPHALT BINDER COURSE, IL-19.0, N90 (FOR SHOULDER AREA WHERE FULL RECON AND GRADE CORRECTION, REFER TO TYPICAL SECTIONS)
 - PROPOSED POLYMERIZED HOT-MIX ASPHALT BINDER COURSE, IL-4.75, N50
 - PROPOSED POLYMERIZED HOT-MIX ASPHALT SURFACE COURSE, SMA 9.5, MIX "F" N80
 - ③ HMA PE
 - PROPOSED HOT-MIX ASPHALT BASE COURSE, 6"
 - PROPOSED HOT-MIX ASPHALT SURFACE COURSE, MIX "D", N50, 2"
 - ④ HMA CE
 - PROPOSED HOT-MIX ASPHALT BASE COURSE, 8"
 - PROPOSED HOT-MIX ASPHALT SURFACE COURSE, MIX "D", N50, 2"
- NOTE: REFER TO SCHEDULE OF QUANTITIES FOR LOCATIONS OF TREE REMOVALS.

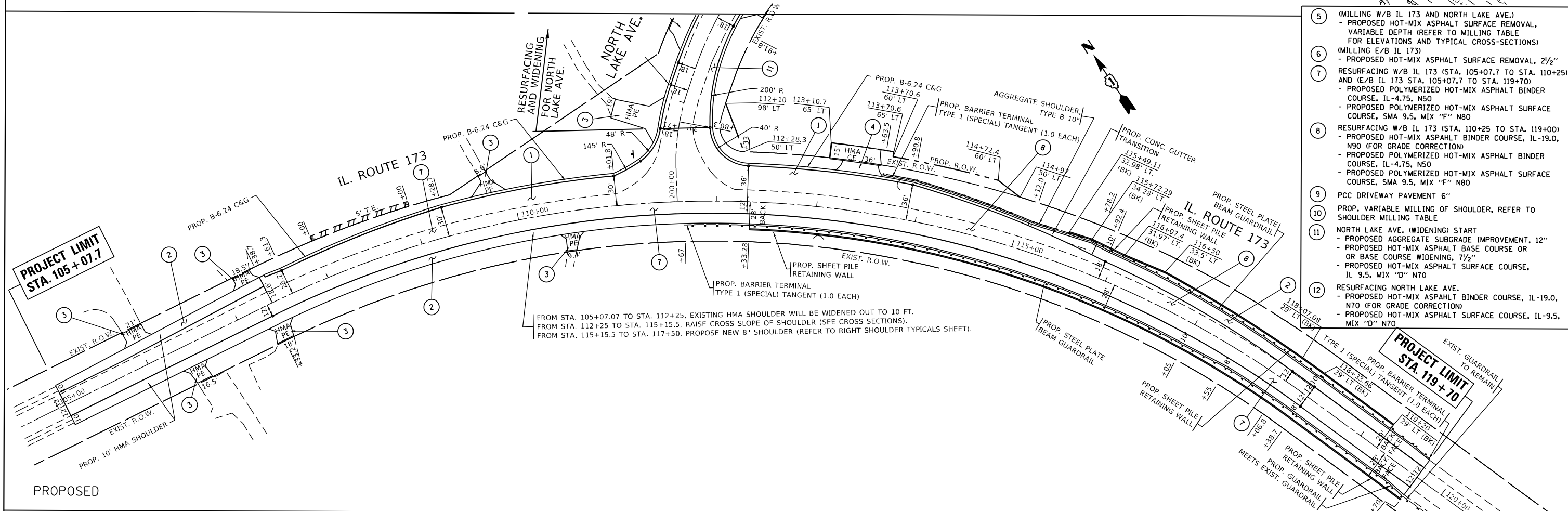

- ⑤ (MILLING W/B IL 173 AND NORTH LAKE AVE.)
 - PROPOSED HOT-MIX ASPHALT SURFACE REMOVAL, VARIABLE DEPTH (REFER TO MILLING TABLE FOR ELEVATIONS AND TYPICAL CROSS-SECTIONS)
- ⑥ (MILLING E/B IL 173)
- ⑦ RESURFACING W/B IL 173 (STA. 105+07.7 TO STA. 110+25) AND (E/B IL 173 STA. 105+07.7 TO STA. 119+70)
 - PROPOSED POLYMERIZED HOT-MIX ASPHALT BINDER COURSE, IL-4.75, N50
 - PROPOSED POLYMERIZED HOT-MIX ASPHALT SURFACE COURSE, SMA 9.5, MIX "F" N80
- ⑧ RESURFACING W/B IL 173 (STA. 110+25 TO STA. 119+00)
 - PROPOSED HOT-MIX ASPHALT BINDER COURSE, IL-19.0, N90 (FOR GRADE CORRECTION)
 - PROPOSED POLYMERIZED HOT-MIX ASPHALT BINDER COURSE, IL-4.75, N50
 - PROPOSED POLYMERIZED HOT-MIX ASPHALT SURFACE COURSE, SMA 9.5, MIX "F" N80
- ⑨ PCC DRIVEWAY PAVEMENT 6"
- ⑩ PROP. VARIABLE MILLING OF SHOULDER, REFER TO SHOULDER MILLING TABLE
- ⑪ NORTH LAKE AVE. (WIDENING) START
 - PROPOSED AGGREGATE SUBGRADE IMPROVEMENT, 12"
 - PROPOSED HOT-MIX ASPHALT BASE COURSE OR OR BASE COURSE WIDENING, 7 1/2"
 - PROPOSED HOT-MIX ASPHALT SURFACE COURSE, IL 9.5, MIX "D" N70
- ⑫ RESURFACING NORTH LAKE AVE.
 - PROPOSED HOT-MIX ASPHALT BINDER COURSE, IL-19.0, N70 (FOR GRADE CORRECTION)
 - PROPOSED HOT-MIX ASPHALT SURFACE COURSE, IL-9.5, MIX "D" N70

FILE NAME =	USER NAME = kalorm	DESIGNED -	REVISED - RK - 3/15/2021	STATE OF ILLINOIS DEPARTMENT OF TRANSPORTATION	ROADWAY PLAN IL. ROUTE 173 AT NORTH LAKE AVE.		F.A.P. RTE.	SECTION	COUNTY	TOTAL SHEETS	SHEET NO.
pw:\planroom\dot.illinois.gov\PIDOT\Documents\1D0T Offices\District I\Projects\P171909\Drawings\CAD\Sheets\P171909-shr-plnprf.dwg		CHECKED -	REVISED -		303	134&134XIN	LAKE	129	47		
Default		PLOT SCALE = 100.0000' / in.	REVISED -		CONTRACT NO. 60V39			ILLINOIS FED. AID PROJECT			

SCALE: 1"=50' SHEET OF SHEETS STA. TO STA.

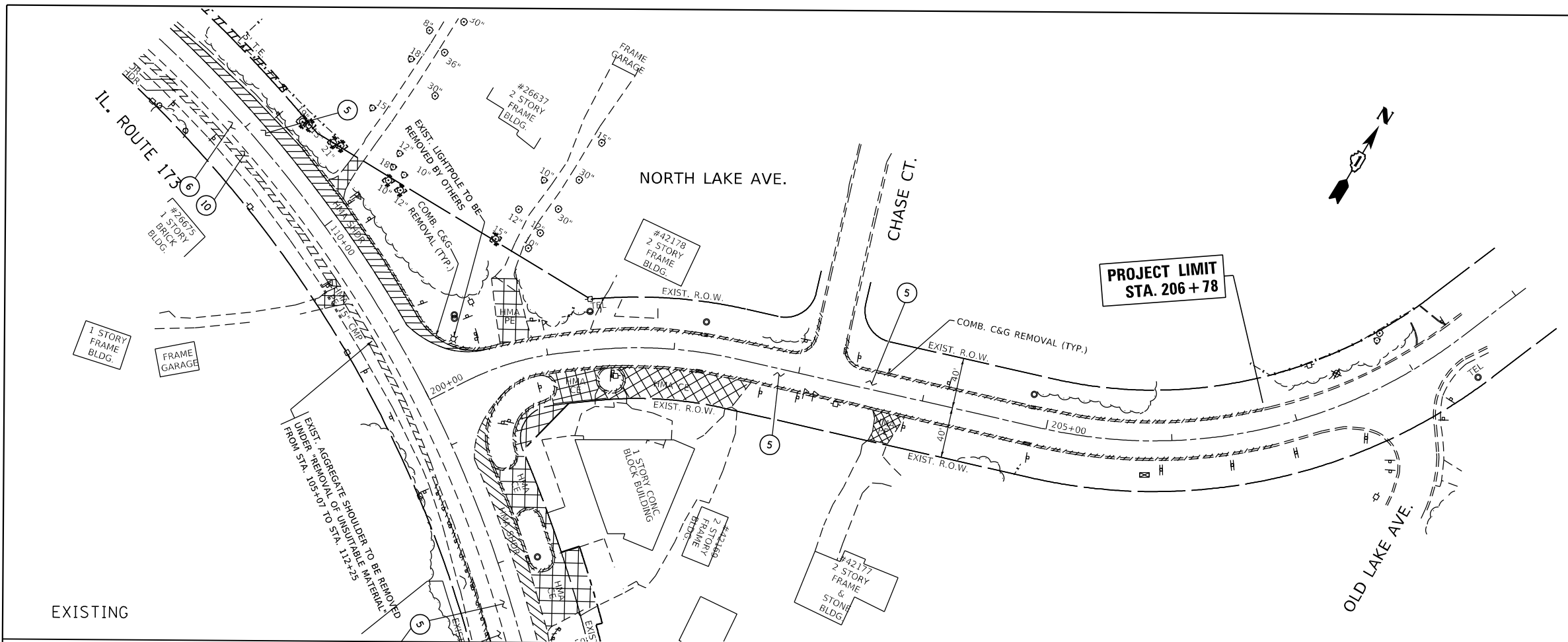

- LEGEND:**
- 1 IL. RTE. 173 (WIDENING)
 - PROPOSED AGGREGATE SUBGRADE IMPROVEMENT, 12"
 - PROPOSED HOT-MIX ASPHALT BASE COURSE OR OR BASE COURSE WIDENING, 7 1/2"
 - PROPOSED POLYMERIZED HOT-MIX ASPHALT BINDER COURSE, IL-4.75, N50
 - PROPOSED POLYMERIZED HOT-MIX ASPHALT SURFACE COURSE, SMA 9.5, MIX "F" N80
 - 2 HMA SHOULDER
 - PROPOSED HOT-MIX ASPHALT BINDER COURSE, IL-19.0, N90 (FOR SHOULDER AREA WHERE FULL RECON AND GRADE CORRECTION, REFER TO TYPICAL SECTIONS)
 - PROPOSED POLYMERIZED HOT-MIX ASPHALT BINDER COURSE, IL-4.75, N50
 - PROPOSED POLYMERIZED HOT-MIX ASPHALT SURFACE COURSE, SMA 9.5, MIX "F" N80
 - 3 HMA PE
 - PROPOSED HOT-MIX ASPHALT BASE COURSE, 6"
 - PROPOSED HOT-MIX ASPHALT SURFACE COURSE, MIX "D", N50, 2"
 - 4 HMA CE
 - PROPOSED HOT-MIX ASPHALT BASE COURSE, 8"
 - PROPOSED HOT-MIX ASPHALT SURFACE COURSE, MIX "D", N50, 2"
 - 5 (MILLING W/B IL 173 AND NORTH LAKE AVE.)
 - PROPOSED HOT-MIX ASPHALT SURFACE REMOVAL, VARIABLE DEPTH (REFER TO MILLING TABLE FOR ELEVATIONS AND TYPICAL CROSS-SECTIONS)
 - 6 (MILLING E/B IL 173)
 - PROPOSED HOT-MIX ASPHALT SURFACE REMOVAL, 2 1/2"
 - 7 RESURFACING W/B IL 173 (STA. 105+07.7 TO STA. 110+25) AND (E/B IL 173 STA. 105+07.7 TO STA. 119+70)
 - PROPOSED POLYMERIZED HOT-MIX ASPHALT BINDER COURSE, IL-4.75, N50
 - PROPOSED POLYMERIZED HOT-MIX ASPHALT SURFACE COURSE, SMA 9.5, MIX "F" N80
 - 8 RESURFACING W/B IL 173 (STA. 110+25 TO STA. 119+00)
 - PROPOSED HOT-MIX ASPHALT BINDER COURSE, IL-19.0, N90 (FOR GRADE CORRECTION)
 - PROPOSED POLYMERIZED HOT-MIX ASPHALT BINDER COURSE, IL-4.75, N50
 - PROPOSED POLYMERIZED HOT-MIX ASPHALT SURFACE COURSE, SMA 9.5, MIX "F" N80
 - 9 PCC DRIVEWAY PAVEMENT 6"
 - 10 PROP. VARIABLE MILLING OF SHOULDER, REFER TO SHOULDER MILLING TABLE
 - 11 NORTH LAKE AVE. (WIDENING) START
 - PROPOSED AGGREGATE SUBGRADE IMPROVEMENT, 12"
 - PROPOSED HOT-MIX ASPHALT BASE COURSE OR OR BASE COURSE WIDENING, 7 1/2"
 - PROPOSED HOT-MIX ASPHALT SURFACE COURSE, IL 9.5, MIX "D" N70
 - 12 RESURFACING NORTH LAKE AVE.
 - PROPOSED HOT-MIX ASPHALT BINDER COURSE, IL-19.0, N70 (FOR GRADE CORRECTION)
 - PROPOSED HOT-MIX ASPHALT SURFACE COURSE, IL-9.5, MIX "D" N70

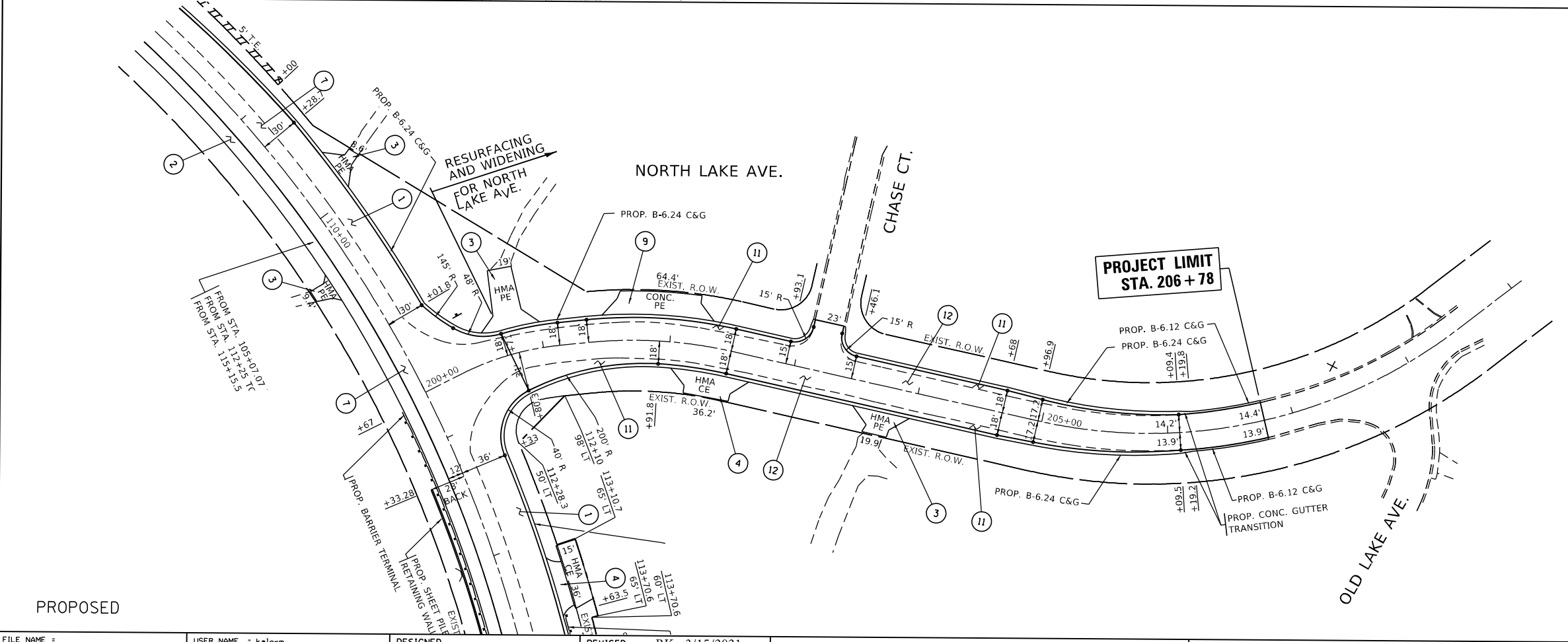

FILE NAME =	USER NAME = kalorm	DESIGNED =	REVISED = RK - 3/15/2021	STATE OF ILLINOIS DEPARTMENT OF TRANSPORTATION	ROADWAY PLAN IL. ROUTE 173 AT NORTH LAKE AVE.			F.A.P. RTE. 303	SECTION (134&134XIN	COUNTY LAKE	TOTAL SHEETS 129	SHEET NO. 48
pw\p\planroom.dot\illinois.gov\PIWIDOT\Documents\DOT Offices\District 1\Projects\P171909\DRAWING\CADsheets\P171909-sht-p1npr.f.dwg		CHECKED =	REVISED =		SCALE: 1"=50'	SHEET	OF	SHEETS	STA.	TO	STA.	CONTRACT NO. 60V39
Default		PLOT SCALE = 100.0000' / in.	REVISED =									ILLINOIS FED. AID PROJECT
		PLOT DATE = 3/14/2021	REVISED =									

PLAN	SURVEYED	DATE
NOTE BOOK NO.	PLOTTED	BY
	ALIGNMENT CHECKED	
	CADD FILE NAME	

PROFILE	SURVEYED	DATE
NOTE BOOK NO.	PLOTTED	BY
	GRADES CHECKED	
	STRUCTURE NOTATIONS CHECKED	

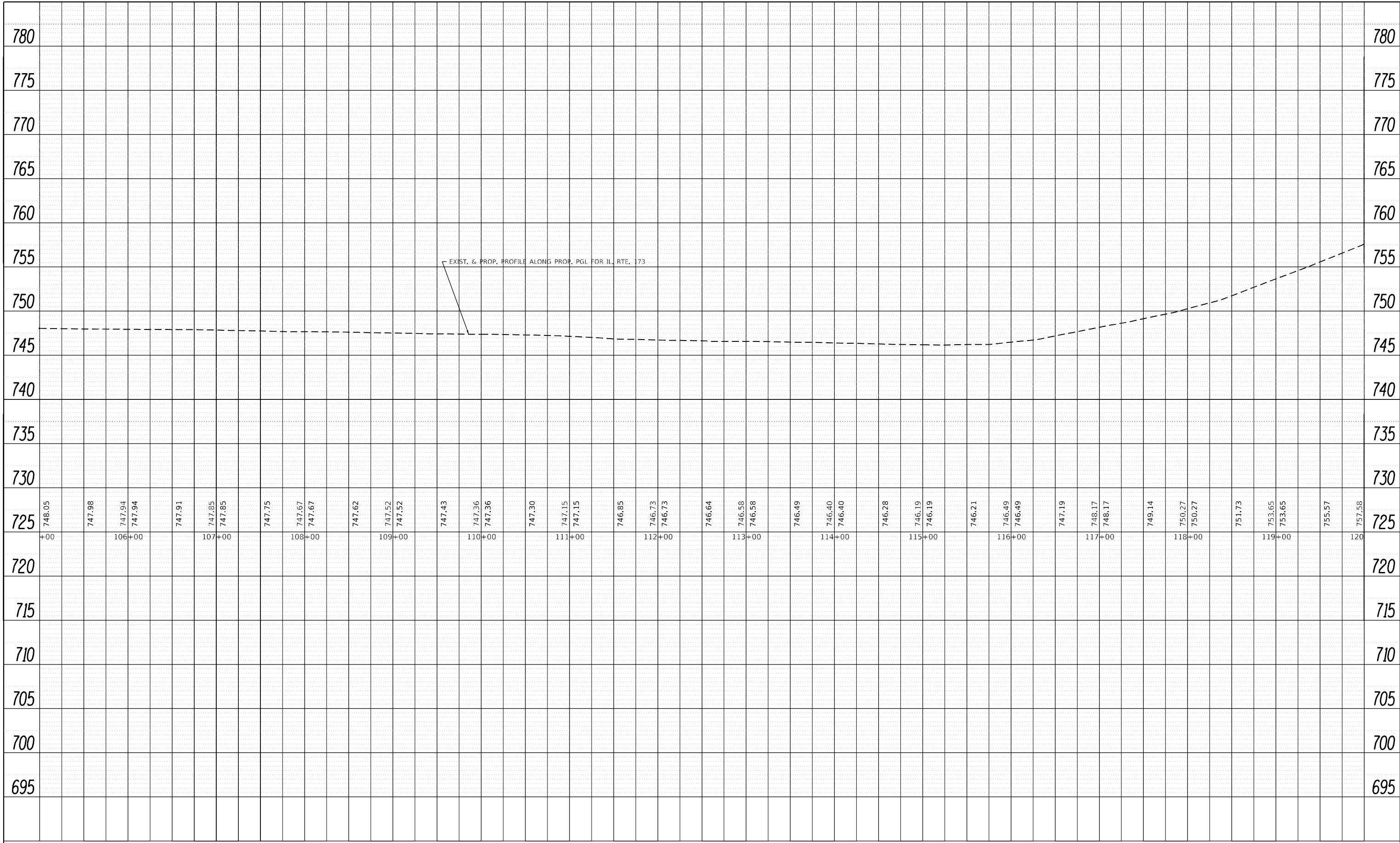

FILE NAME =	USER NAME = kalorm	DESIGNED -	REVISED -
p:\plnroom.dot\illinois.gov\PIWIDOT\Documents\DOT Offices\District 1\Projects\171909\DRAWN\CAD\Sheets\171909-sh1-plnprf.dgn		CHECKED -	REVISED -
Default	PLOT DATE = 1/27/2021	DATE -	REVISED -

**STATE OF ILLINOIS
DEPARTMENT OF TRANSPORTATION**

ROADWAY PROFILE			
IL. ROUTE 173 AT NORTH LAKE AVE.			
SCALE: 1"=50'	SHEET	OF	SHEETS
	STA.		TO STA.

F.A.P. RTE.	SECTION	COUNTY	TOTAL SHEETS	SHEET NO.
303	(134&134)XN	LAKE	129	49
CONTRACT NO. 60V39			ILLINOIS FED. AID PROJECT	

PLAN	SURVEYED	BY	DATE
	PLOTTED		
	ALIGNED		
	CHECKED		
	FILED		
NO.	CAD FILE NAME		

PROFILE	SURVEYED	BY	DATE
	PLOTTED		
	GRADES CHECKED		
	STRUCTURE NOTATIONS CHECKED		
NO.			

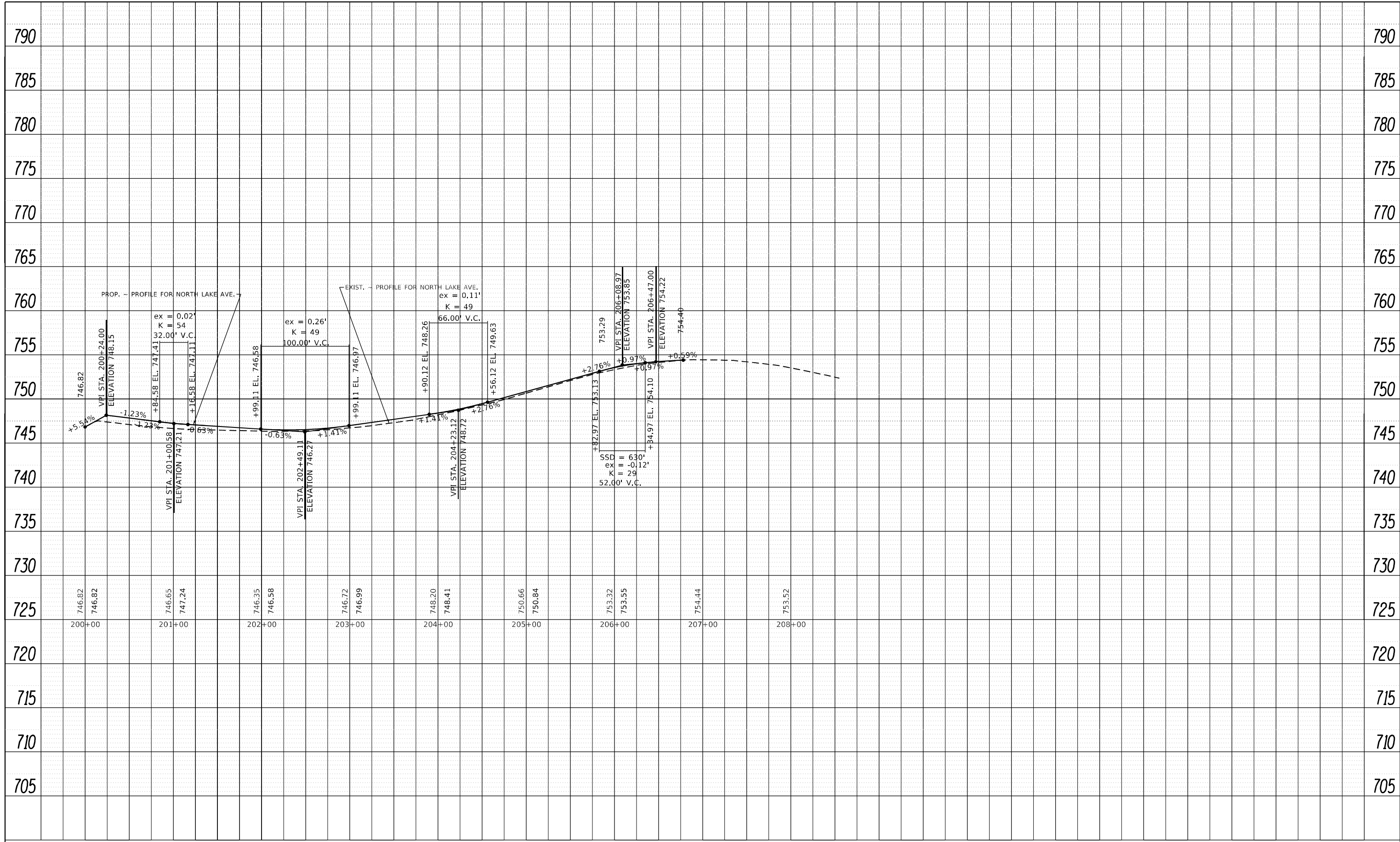

FILE NAME =	USER NAME = kalorm	DESIGNED -	REVISED -
p:\plnroom.dot\illinois.gov\PI\DOT\Documents\DOT Offices\District 1\Projects\171909\CDRAW\CADsheets\171909-sh1-plnprf.dgn		REVISED -	REVISED -
Default	PLOT SCALE = 100.0000' / in.	CHECKED -	REVISED -
	PLOT DATE = 1/27/2021	DATE -	REVISED -

**STATE OF ILLINOIS
DEPARTMENT OF TRANSPORTATION**

ROADWAY PROFILE			
IL. ROUTE 173 AT NORTH LAKE AVE.			
SCALE: 1"=50'	SHEET	OF SHEETS	STA. TO STA.

F.A.P. RTE.	SECTION	COUNTY	TOTAL SHEETS	SHEET NO.
303	(134&134)XIN	LAKE	129	50
				CONTRACT NO. 60V39
ILLINOIS FED. AID PROJECT				

EROSION CONTROL GENERAL NOTES

1. THE CONTRACTOR WILL BE REQUIRED TO IMPLEMENT AND MAINTAIN EROSION CONTROL MEASURES IMMEDIATELY AFTER STRIPPING OF EXISTING VEGETATION.
2. NO RUNOFF FROM STRIPPED AREAS WILL LEAVE THE SITE OTHER THAN THROUGH A SERIES OF TEMP DITCH CHECKS. THE CONTRACTOR WILL ADJUST HIS OPERATIONS AND IMPLEMENT EROSION CONTROL MEASURES ACCORDINGLY.
3. THE QUANTITIES SHOWN FOR TEMPORARY DITCH CHECKS ARE MEASURED PER FOOT, REGARDLESS OF TYPE OR CONFIGURATION USED.
4. THE CONTRACTOR SHALL SURROUND ALL EARTH STOCKPILES WITH SILT FENCE, THIS SHALL BE PAID FOR AS PERIMETER EROSION BARRIER. EROSION CONTROL MEASURES SHALL BE INSPECTED BY THE CONTRACTOR AND ENGINEER AFTER ANY STORM EXCEEDING 0.5 INCH OR GREATER IN A 24 HOUR PERIOD, OR EQUIVALENT SNOWFALL. ADDITIONALLY DURING WINTER MONTHS, ALL MEASURES SHOULD BE CHECKED AFTER EACH SIGNIFICANT SNOWMELT.
5. STOCKPILES OF SOIL AND OTHER BUILDING MATERIALS TO REMAIN IN PLACE MORE THAN THREE (3) DAYS SHALL BE FURNISHED WITH EROSION AND SEDIMENT CONTROL MEASURES (I.E. PERIMETER SILT FENCE). STOCKPILES TO REMAIN IN PLACE FOR 14 DAYS OR MORE SHALL RECEIVE TEMPORARY SEEDING WITHIN 7 DAYS.
6. ALL CONSTRUCTION ACTIVITIES SHALL BE IN ACCORDANCE WITH THE NATIONAL POLLUTANT DISCHARGE ELIMINATION SYSTEM STORM WATER PERMIT.
7. THE CONTRACTOR SHALL TAKE ALL PRECAUTIONS TO PREVENT POLLUTION OF STORM WATER AND SHALL FOLLOW IEPA & IDOT CONSTRUCTION MEMORANDUM NO. 06-60.
8. EROSION CONTROL SHALL BE PROVIDED IN ACCORDANCE WITH SEQUENCE OF STAGE CONSTRUCTION.
9. STABILIZATION MEASURES SHALL BE INITIATED AS SOON AS PRACTICAL, BUT IN NO CASE EXCEED 7 DAYS AFTER CONSTRUCTION ACTIVITY IN THAT PORTION OF THE SITE HAS TEMPORARILY OR PERMANENTLY CEASED ON ALL DISTURBED PORTIONS OF THE SITE WHERE CONSTRUCTION ACTIVITY WILL NOT OCCUR FOR A PERIOD OF 14 OR MORE CALENDER DAYS.
10. THE CONTRACTOR SHALL APPLY TEMPORARY EROSION CONTROL SEEDING TO ALL ERODIBLE BARE EARTH AREAS WITHIN THE CONTRACT LIMITS EACH WEEK, REGARDLESS OF WEATHER CONDITIONS OR PROGRESS OF THE WORK. UNLESS OTHERWISE DIRECTED BY THE ENGINEER. ERODIBLE EMBANKMENT AND EXCAVATION AREAS WHERE WORK IS IN PROGRESS SHALL BE INCLUDED ON THE AREAS TO BE SEEDED. SEE SPECIAL PROVISION FOR TEMPORARY EROSION CONTROL SEEDING.
11. ALL PERIMETER EROSION BARRIER SHALL BE PLACED IN STAGE I, IF REQUIRED IN STAGE II & III IT SHALL BE LEFT IN PLACE. IT SHALL ONLY BR REPLACED IF DAMAGED, AT THE DIRECTION OF THE ENGINEER.
12. REFER TO LANDSCAPING PLAN FOR AREAS TO BE SEEDED
13. UNLESS OTHERWISE INDICATED, ALL VEGETATIVE AND STRUCTURAL EROSION AND SEDIMENT CONTROL PRACTICES WILL BE CONSTRUCTED ACCORDING TO MINIMUM STANDARDS AND SPECIFICATIONS IN THE ILLINOIS URBAN MANUAL REVISED JUNE 2013.
14. A COPY OF THE APPROVED EROSION AND SEDIMENT CONTROL PLAN SHALL BE MAINTAINED ON THE SITE AT ALL TIMES.
15. DEWATERING SHALL BE CONDUCTED IN ACCORDANCE WITH IUM STANDARD 813 (UPDATED 06/2010). DEWATERING INTO DRAIN TILES IS STRICTLY PROHIBITED. COMPROMISED DRAIN TILES SHOULD BE IMMEDIATELY REPAIRED OR INCORPORATED INTO STORM WATER FACILITIES.
16. ALL DROP INLETS ON AND ADJACENT TO THE SITE MUST HAVE A SEDIMENT TRAPPING OR CONTAINMENT DEVICE INSTALLED DURING CONSTRUCTION ACTIVITIES.
17. ALL ADJACENT STREETS MUST BE KEPT CLEAR OF DEBRIS, INSPECTED DAILY AND CLEANED WHEN NECESSARY.
18. EROSION CONTROL BLANKET AND/OR STRAW MULCH WITH NETTING (DEPENDING ON SLOPE, SLOPE LENGTH, AND FLOW RATES) SHALL BE INSTALLED ON ALL SLOPES AND IN CRITICAL AREAS IMMEDIATELY UPON FINAL GRADING.
19. THE CONDITION OF THE CONSTRUCTION SITE FOR WINTER SHUTDOWN SHALL BE ADDRESSED EARLY IN THE FALL GROWING SEASON SO THAT SLOPES AND OTHER BARE EARTH AREAS MAY BE STABILIZED WITH TEMPORARY AND/OR PERMANENT VEGETATIVE COVER FOR PROPER EROSION AND SEDIMENT CONTROL. ALL OPEN AREAS THAT ARE TO REMAIN IDLE THROUGHOUT THE WINTER SHALL RECEIVE TEMPORARY EROSION CONTROL MEASURES INCLUDING TEMPORARY SEEDING, MULCHING AND/OR EROSION CONTROL BLANKET PRIOR TO THE END OF THE FALL GROWING SEASON. THE AREAS TO BE WORKED BEYOND THE END OF THE GROWING SEASON MUST INCORPORATE SOIL STABILIZATION MEASURES THAT DO NOT RELY ON VEGETATIVE COVER SUCH AS EROSION CONTROL BLANKET AND HEAVY MULCHING.
20. IN AREAS WHERE WORK IS COMPLETE, PERMANENT STABILIZATION SHALL OCCUR WITHIN 1 DAY OF COMPLETION, AND IN AREAS WHERE WORK HAS TEMPORARILY CEASED FOR 14 DAYS OR MORE, TEMPORARY STABILIZATION SHALL OCCUR BY THE 1ST DAY AFTER WORK HAS CEASED.
21. COMPLETED SLOPES SHALL BE SEEDED AND MULCHED (OR BLANKETED, IF APPLICABLE) AS THE EXCAVATION PROCEEDS TO THE EXTENT CONSIDERED DESIRABLE AND PRACTICAL. PERMANENT SEEDING SHALL BE USED WHENEVER POSSIBLE. UNDER NO CIRCUMSTANCES SHALL THE CONTRACTOR PROLONG FINAL GRADING AND SHAPING SO THAT THE ENTIRE PROJECT CAN BE PERMANENTLY SEEDED AT ONE TIME. NO WORK SHALL BE PERFORMED IN FLOWING WATER. WATER IN AND NEAR THE CRITICAL AREAS SHOULD BE ISOLATED FROM CONCENTRATED FLOWS OR STREAM FLOW. THE STREAM BANKS SHOULD BE STABILIZED AT THE END OF EACH DAY. ONCE WORK IN THIS AREA BEGINS, PRIORITY SHALL BE GIVEN TO THE COMPLETION OF THE WORK AND FINAL STABILIZATION OF ALL DISTURBED AREAS.
22. THE DEPARTMENT HAS NOT OBTAINED ANY PERMITS FOR OFFSITE BORROW, WASTE, USE (BWU) AREAS, PRIOR TO WORKING IN BWU AREAS. IF THE CONTRACTOR CHOOSES TO USE ACTIVITIES REQUIRING PERMITS IT IS THE CONTRACTOR'S RESPONSIBILITY TO SECURE THE PROPER PERMITS. IN ADDITION TO THE BORROW REVIEW (BDE 2289) AND USE/WASTE REVIEW (BDE 2290) SUBMITTALS, THE CONTRACTOR SHALL SUBMIT AN EROSION AND SEDIMENT CONTROL (ESC) PLAN FOR EVERY BWU SITE TO THE DEPARTMENT FOR ACCEPTANCE. GUIDELINES FOR ACCEPTABLE BWU PRACTICES CAN BE FOUND IN SECTION II.G.1 AND 2 OF THE SWPPP. THE COST OF ALL MATERIALS AND LABOR NECESSARY TO COMPLY WITH THE ABOVE PROVISIONS TO PREPARE AND IMPLEMENT ESC PLANS WILL NOT BE PAID FOR SEPARATELY, BUT SHALL BE CONSIDERED AS INCLUDED IN THE UNIT BID PRICES OF THE CONTRACT AND NO ADDITIONAL COMPENSATION WILL BE ALLOWED.
23. ALL ESC MEASURES WILL BE MAINTAINED IN ACCORDANCE WITH THE IDOT EROSION AND SEDIMENT CONTROL FIELD GUIDE FOR CONSTRUCTION INSPECTION FOUND ON THE CONSTRUCTION TAB AT: (HTTP://WWW.IDOT.ILLINOIS.GOV/TRANSPORTATION-SYSTEM/ENVIRONMENT/EROSION-AND-SEDIMENT-CONTROL).
24. THE CONTRACTOR SHALL CHECK ALL ESC MEASURES WEEKLY AND AFTER EACH RAINFALL, 0.5 INCHES OR GREATER IN A 24 HOUR PERIOD, OR EQUIVALENT SNOWFALL. ADDITIONALLY DURING WINTER MONTHS, ALL MEASURES SHOULD BE CHECKED BY THE CONTRACTOR AFTER EACH SIGNIFICANT SNOWMELT.
25. THE CONTRACTOR SHOULD PROVIDE TO THE RE A PLAN TO ENSURE THAT A STABILIZED FLOW LINE WILL BE PROVIDED DURING STORM SEWER CONSTRUCTION. THE USE OF A STABILIZED FLOW LINE BETWEEN INSTALLED STORM SEWER AND OPEN DISTURBANCE WILL REDUCE THE POTENTIAL FOR THE OFFSITE DISCHARGE OF SEDIMENT-BEARING WATERS, ESPECIALLY WHEN RAIN IS FORECASTED, SO THAT FLOW WILL NOT ERODE. LACK OF APPROVED PLAN OR FAILURE TO COMPLY WILL RESULT IN AN ESC DEFICIENCY DEDUCTION.
26. ANY LOOSE MATERIAL DEPOSITED IN THE FLOW LINE OF DRAINAGE STRUCTURES, WHICH OBSTRUCTS THE NATURAL FLOW OF WATER, SHALL BE REMOVED AT THE CLOSE OF EACH WORKING DAY. PRIOR TO ACCEPTANCE OF THE IMPROVEMENT, ALL DRAINAGE STRUCTURES SHALL BE FREE OF DIRT AND DEBRIS. THIS WORK WILL NOT BE PAID FOR SEPARATELY BUT SHALL BE CONSIDERED AS INCIDENTAL.
27. UNDER NO CIRCUMSTANCES SHALL THE CONTRACTOR PROLONG FINAL GRADING AND SHAPING SO THAT THE ENTIRE PROJECT CAN BE PERMANENTLY SEEDED AT ONE TIME.
28. EROSION CONTROL ITEMS ARE CONSIDERED TO BE A HIGH PRIORITY ON THIS CONTRACT. THE CONTRACTOR IS RESPONSIBLE FOR INSTALLATION OF ANY ADDITIONAL EROSION CONTROL MEASURES NECESSARY TO PREVENT EROSION AND SEDIMENTATION AS DETERMINED BY THE RE.
29. THIS PROJECT REQUIRES A US ARMY CORPS OF ENGINEERS (USACE) 404 PERMIT THAT WILL BE SECURED BY THE DEPARTMENT. AS A CONDITION OF THIS PERMIT, THE CONTRACTOR WILL NEED TO SUBMIT AN IN-STREAM WORK PLAN TO THE DEPARTMENT FOR APPROVAL. GUIDELINES ON ACCEPTABLE IN- STREAM WORK TECHNIQUES CAN BE FOUND ON THE USACE WEBSITE. THE USACE DEFINES AND DETERMINES IN-STREAM WORK. THE COST OF ALL MATERIALS AND LABOR NECESSARY TO COMPLY WITH THE ABOVE PROVISIONS TO PREPARE AND IMPLEMENT AN IN-STREAM WORK PLAN WILL NOT BE PAID FOR SEPARATELY, BUT SHALL BE CONSIDERED AS INCLUDED IN THE UNIT BID PRICES OF THE CONTRACT AND NO ADDITIONAL COMPENSATION WILL BE ALLOWED WITH THE EXCEPTION OF COFFERDAMS WHICH WILL BE PAID FOR AS COFFERDMAN (TYPE 1) (IN-STREAM/WETLAND WORK) WITH A BASIS OF PAYMENT OF EACH.
30. "WETLANDS NO INTRUSION" SIGNAGE SHOULD ALSO BE PROVIDED AT THE BOUNDARY OF ALL UN-IMPACTED WETLANDS AND/OR WOUS. THE CONTRACTOR CAN BORROW THE SIGNS FROM THE BUREAU OF MAINTENANCE. INCLUDE TEMPORARY FENCING AND WETLAND SIGNAGE WITHIN THE EROSION AND SEDIMENT CONTROL STRATEGY.

COMMITMENTS

1. PER REQUIREMENTS SET BY IDNR, NO-INTRUSION/SILT FENCE SHALL BE INSTALLED AS OUTLINED IN THE CONTRACT PLANS TO PREVENT IMPACTS TO THE ADJACENT STATE PARK

FILE NAME =	USER NAME = kalorm	DESIGNED -	REVISED - RK - 3/15/2021	STATE OF ILLINOIS DEPARTMENT OF TRANSPORTATION	IL. ROUTE 173 AT NORTH LAKE AVENUE EROSION CONTROL NOTES			F.A.P. RTE.	SECTION	COUNTY	TOTAL SHEETS	SHEET NO.
p:\planroom.dot.illinois.gov\PIDOT\Documents\IDOT Offices\District 1\Projects\P171909\DRAWING\Design\P171909-sht-details.dgn		CHECKED -	REVISED -					303	(134&134X)N	LAKE	129	51
PLOT SCALE = 100.0000' / in.		DATE -	REVISED -		CONTRACT NO. 60V39							
PLOT DATE = 3/15/2021					SCALE:	SHEET NO.	OF SHEETS	STA.	TO STA.	ILLINOIS FED. AID PROJECT		

NOTE:

THIS PROJECT REQUIRES A US ARMY CORPS OF ENGINEER (USACE) 404 PERMIT THAT WILL BE SECURED BY THE DEPARTMENT.

INSTALL PERIMETER EROSION BARRIER ALONG R.O.W. & TEMPORARY EASEMENTS, AS SHOWN ON PLANS.

INSTALL TEMPORARY FENCE ALONG R.O.W. & TEMPORARY EASEMENTS, AS SHOWN ON PLANS.

EXCAVATION FOR THE INSTALLATION OF RIP RAP WILL BE PAID FOR AS "REMOVAL AND DISPOSAL OF UNSUITABLE MATERIAL" PER CU. YD.

* INSTALL INLET FILTERS ON ALL OPEN STRUCTURES.

INSTALL IDOT PROVIDED "WETLAND NO INTRUSION" SIGNAGE AT THE BOUNDARY OF ALL UNIMPACTED WETLANDS. CONTRACTOR SHALL CONTACT IDOT ROADSIDE DEVELOPMENT UNIT AT (847) 705-4171 TO OBTAIN THESE SIGNS.

LEGEND

SYMBOL	DESCRIPTION
	PERIMETER EROSION BARRIER (SILT FENCE, SEE STANDARD 280001)
	TEMPORARY DITCH CHECK
	EXIST. R.O.W.
	PROP. R.O.W.
	PROP. TEMPORARY EASEMENT
	PROP. RIP RAP
	INLET FILTER *
*	ITEMS TO BE INSTALLED BEFORE THE AREA IS DISTURBED.
	TEMPORARY FENCE
	MANHOLE
	CATCH BASIN
	INLET

TEMPORARY EROSION CONTROL SEQUENCE OF CONSTRUCTION

1. ESTABLISH TEMPORARY EROSION CONTROL MEASURES AND ERECT SILT FENCE ALONG SITE BOUNDARIES AS SHOWN ON PLAN PRIOR TO MASS EARTHWORK.
2. INSTALL DITCH CHECKS IMMEDIATELY AFTER DITCH DISTURBANCE STARTS.
3. INSTALL PERMANENT SEEDING BEFORE BEGINNING NEXT CONSTRUCTION STAGE.

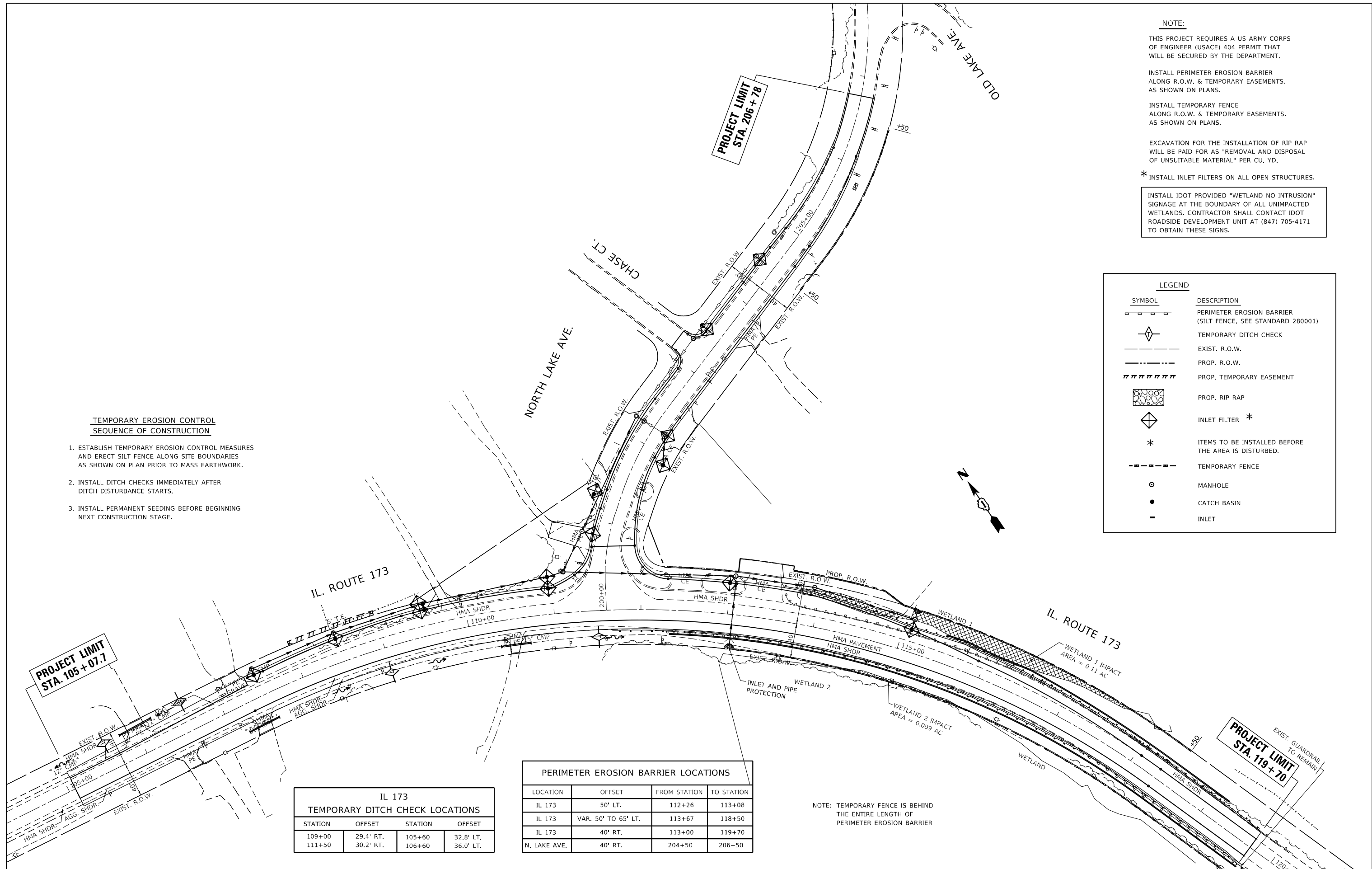

IL 173 TEMPORARY DITCH CHECK LOCATIONS

STATION	OFFSET	STATION	OFFSET
109+00	29.4' RT.	105+60	32.8' LT.
111+50	30.2' RT.	106+60	36.0' LT.

PERIMETER EROSION BARRIER LOCATIONS

LOCATION	OFFSET	FROM STATION	TO STATION
IL 173	50' LT.	112+26	113+08
IL 173	VAR. 50' TO 65' LT.	113+67	118+50
IL 173	40' RT.	113+00	119+70
N. LAKE AVE.	40' RT.	204+50	206+50

NOTE: TEMPORARY FENCE IS BEHIND THE ENTIRE LENGTH OF PERIMETER EROSION BARRIER

FILE NAME =	USER NAME = kalorm	DESIGNED -	REVISED - RK - 3/15/2021
pw:\planroom.dot.illinois.gov\PIDOT\Documents\IDOT Offices\District 1\Projects\P171909\CAD\Sheets\P171909-sht-eros.dgn		DRAWN -	REVISED -
Default	PLOT SCALE = 100.0000' / in.	CHECKED -	REVISED -
	PLOT DATE = 3/14/2021	DATE -	REVISED -

STATE OF ILLINOIS DEPARTMENT OF TRANSPORTATION

EROSION CONTROL PLAN IL. ROUTE 173 AT NORTH LAKE AVE.

SCALE: 1"=50' SHEET OF SHEETS STA. TO STA.

F.A.P. RTE.	SECTION	COUNTY	TOTAL SHEETS	SHEET NO.
303	(134&134XIN	LAKE	129	52
CONTRACT NO. 60V39				
ILLINOIS FED. AID PROJECT				

PLAN	SURVEYED	DATE
	PLOTTED	
	ALIGNMENT	
	CHECKED	
	FILE NAME	
	NO.	

PROFILE	SURVEYED	DATE
	PLOTTED	
	GRADES	
	CHECKED	
	STRUCTURE	
	NOTATIONS	
	NO.	

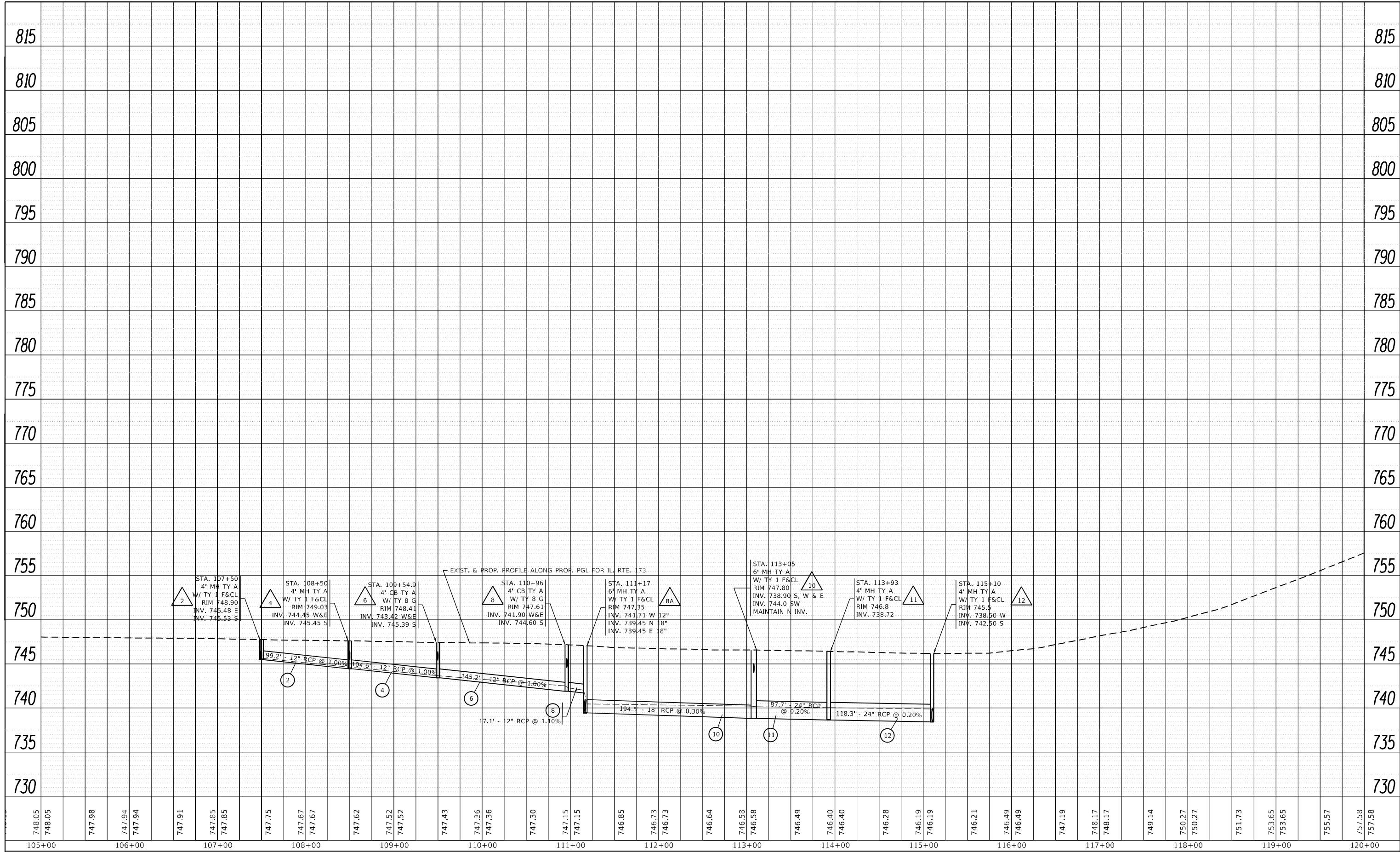

FILE NAME =	USER NAME = kalorm	DESIGNED -	REVISED - RK - 3/15/2021
p:\p\planroom.dot\illinois.gov\PI\DOT\Documents\DOT Offices\District 1\Projects\171909\DRAWN\CAD\Sheets\171909-sh1-drain.dgn		CHECKED -	REVISED -
Default	PLOT DATE = 3/14/2021	DATE -	REVISED -

**STATE OF ILLINOIS
DEPARTMENT OF TRANSPORTATION**

DRAINAGE PROFILE			
IL. ROUTE 173 AT NORTH LAKE AVE.			
SCALE: 1"=50'	SHEET	OF SHEETS	STA. TO STA.

F.A.P. RTE.	SECTION	COUNTY	TOTAL SHEETS	SHEET NO.
303	(1348&134XIN	LAKE	129	54
CONTRACT NO. 60V39				
ILLINOIS FED. AID PROJECT				

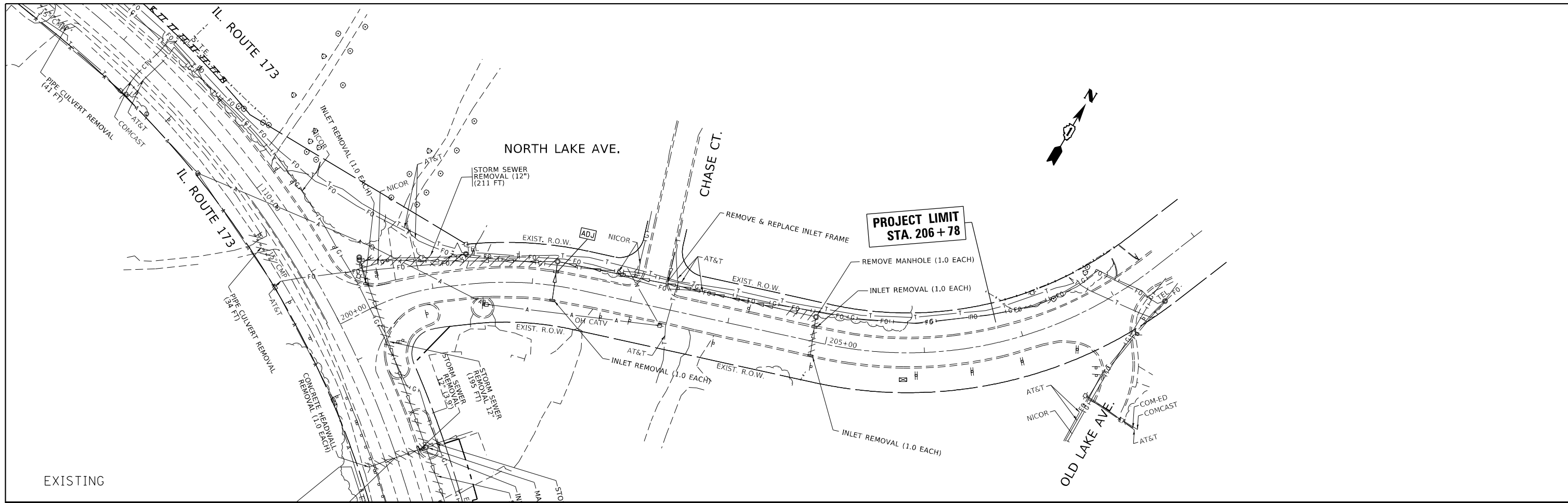

EXISTING

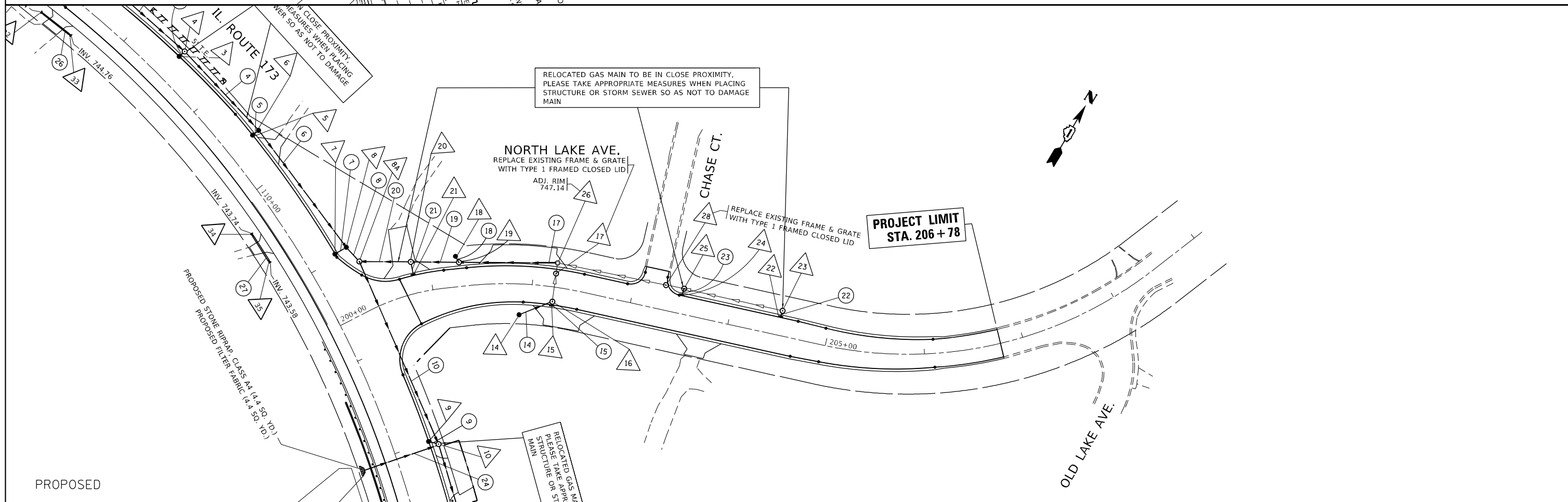

PROPOSED

FILE NAME =	USER NAME = kalorm	DESIGNED -	REVISED -	STATE OF ILLINOIS DEPARTMENT OF TRANSPORTATION	DRAINAGE PLAN IL. ROUTE 173 AT NORTH LAKE AVE.	F.A.P. RTE.	SECTION	COUNTY	TOTAL SHEETS	SHEET NO.
pw:\planroom.dot.illinois.gov\PWIDOT\Documents\IDOT Offices\District 1\Projects\P171909\Drawings\CAD\sheets\P171909-sht-drain.dgn		DRAWN -	REVISED -			303	(134&134XIN	LAKE	129	55
PLOT SCALE = 100.0000' / in.		CHECKED -	REVISED -			CONTRACT NO. 60V39				
Default		DATE -	REVISED -			ILLINOIS FED. AID PROJECT				
					SCALE: 1"=50'	SHEET	OF	SHEETS	STA.	TO STA.

PLAN	SURVEYED	DATE
	PLOTTED	
	ALIGNED	
	CHECKED	
	FILE NAME	
	NO.	

PROFILE	SURVEYED	DATE
	PLOTTED	
	GRADES CHECKED	
	STRUCTURE NOTATIONS CHECKED	
	NO.	

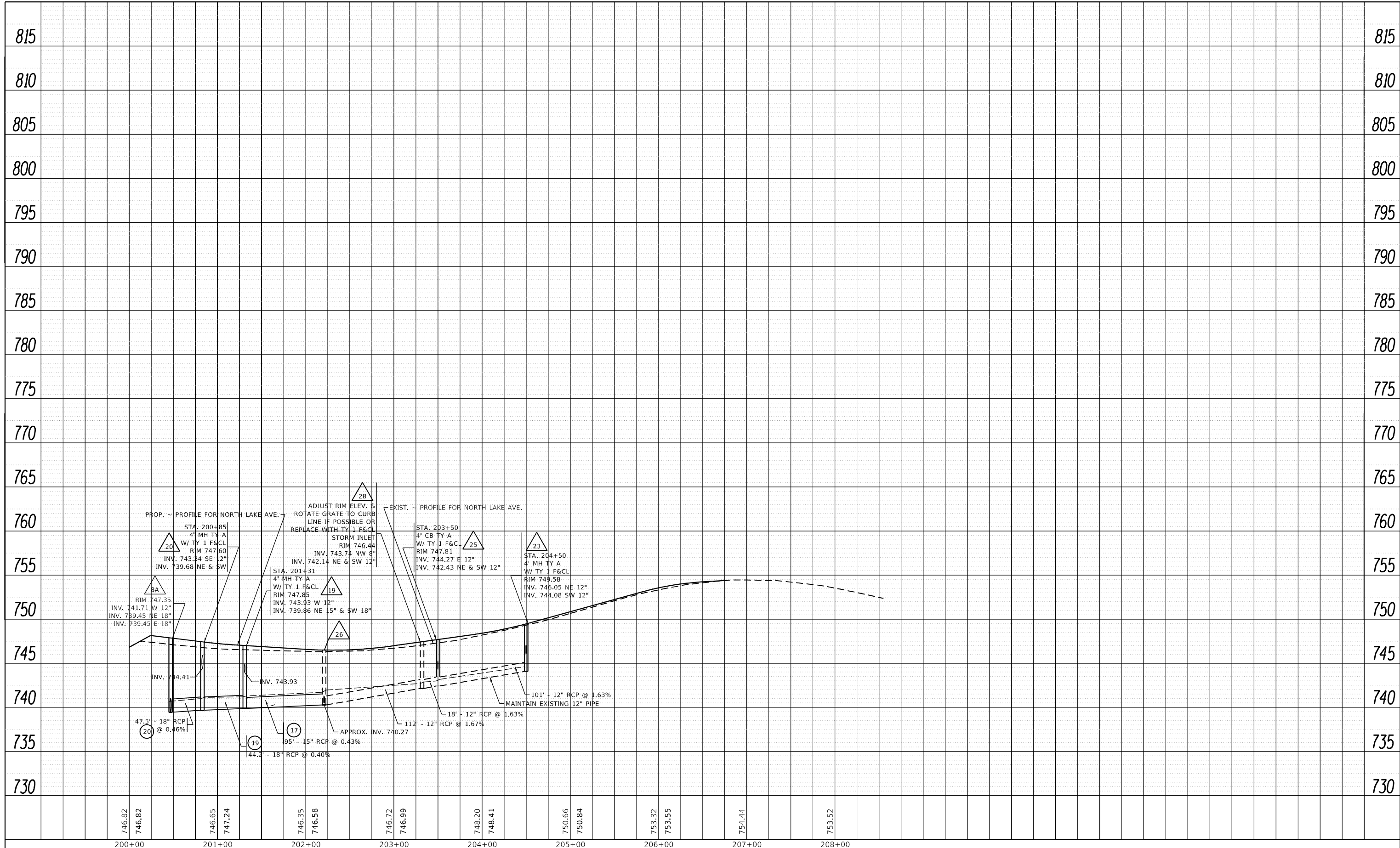

FILE NAME =	USER NAME = kalorm	DESIGNED -	REVISED - RK - 3/15/2021
p:\p\planroom.dot\illinois.gov\PIWIDOT\Documents\DOT Offices\District 1\Projects\171909\DRAWN\CAD\Sheets\171909-sh1-drain.dgn		CHECKED -	REVISED -
Default	PLOT DATE = 3/14/2021	DATE -	REVISED -

**STATE OF ILLINOIS
DEPARTMENT OF TRANSPORTATION**

DRAINAGE PROFILE			
IL. ROUTE 173 AT NORTH LAKE AVE.			
SCALE: 1"=50'	SHEET	OF SHEETS	STA. TO STA.

F.A.P. RTE.	SECTION	COUNTY	TOTAL SHEETS	SHEET NO.
303	(134&134XIN	LAKE	129	56
CONTRACT NO. 60V39				
ILLINOIS FED. AID PROJECT				

STORM SEWER TABLE							
NO.	STATION - STATION	CLASS	TYPE	DIAMETER (IN)	LENGTH (FT)	SLOPE (%)	TBF (CU.YD.)
1	107+50	A	1	12	3.1	1.6	0.22
2	107+50 - 108+50	A	2	12	99.2	1.0	
3	108+50	A	1	12	2.9	4.8	0.24
4	108+50 - 109+54.9	A	2	12	104.6	1.0	34.7
5	109+54.9	A	1	12	3.8	4.7	0.2
6	109+50 - 110+96	A	2	12	145.2	1.0	20.4
7	110+96	A	1	12	8.9	5.8	0.3
8	110+96 - 111+14	A	2	12	17.1	1.1	
9	113+00	A	1	12	4.5	4.0	0.5
10	111+17 - 113+05	A	2	18	194.5	0.3	185.8
11	113+05 - 113+93	A	2	24	87.7	0.2	50.9
12	113+93 - 115+10	A	2	24	118.3	0.2	
13	115+10	A	2	12	8.1	5.9	0.4
14	201+89 - 202+22	A	1	12	31.9	1.1	8.0
15	202+22	A	2	12	1.5	3.3	N/A
16	115+10	A	2	24	6.0	0.2	
17	201+31 - 202+21	A	2	18	95	0.43	69.9
18	201+31	A	1	12	3.3	2.1	N/A
19	200+83 - 201+31	A	2	18	44.2	0.4	13.0
20	200+42 - 200+80	A	2	18	47.5	0.46	20.9
21	200+85	A	2	12	9.3	1.4	0.2
22	204+50	A	1	12	2.4	2.5	0.14
23	203+50	A	1	12	2.9	2.0	0.3
24	113+05	A	3	24	76.0	1.0	67.2

PIPE CULVERT TABLE							
NO.	STATION - STATION	CLASS	TYPE	DIAMETER (IN)	LENGTH (FT)	SLOPE (%)	TBF (CU.YD.)
25	105+82 - 106+22	A	1	12	40.0	0.5	0.6
26	107+20 - 107+52	A	1	15	32.0	0.6	0.4
27	110+35 - 110+67	A	1	15	32.0	0.5	0.3

DRAINAGE NOTES:

- THIS INSTALLATION AND CONNECTION OF A PROPOSED STRUCTURE (CATCH BASING/MANHOLE/INLET) OVER AN EXISTING STORM SEWER AND/OR A PROPOSED STORM SEWER CONNECTION TO AN EXISTING STRUCTURE, AND THE REMOVAL WORK REQUIRED TO MAKE THE CONNECTION WILL NOT BE PAID FOR SEPARATELY, BUT SHALL BE INCLUDED IN THE CONTRACT UNIT PRICE FOR THE ITEM BEING INSTALLED.
- THE INSTALLATION AND CONNECTION OF A PROPOSED STORM SEWER TO AN EXISTING STORM SEWER, AND THE REMOVAL WORK REQUIRED TO MAKE THE CONNECTION WILL NOT BE PAID FOR SEPARATELY, BUT SHALL BE INCLUDED IN THE CONTRACT UNIT PRICE FOR THE ITEM BEING INSTALLED.

- 1 CB, TYP. C, 2' DIA. W/ TYP. 24 FRAME & GRATE STA. 107+50, 25.9' LT T.G. 748.52 AT EOP INV. (OUT) 745.58
- 2 MH, TYP. A, 4' DIA. W/ TYP. 1 FRAME & CL STA. 107+50, 33.2' LT (CENTER MH) RIM 748.90 INV. (IN) 745.53 INV. (OUT) 745.48
- 3 CB, TYP. C, 2' DIA. W/ TYP. 24 FRAME & GRATE STA. 108+50, 27.7' LT T.G. 748.59 AT EOP INV. (OUT) 745.59
- 4 MH, TYP. A, 4' DIA. W/ TYP. 1 FRAME & CL STA. 108+50, 34.8' LT (CENTER MH) RIM 749.03 INV. (IN) S 745.45 INV. (IN) W 744.45 INV. (OUT) E 744.45
- 5 CB, TYP. C, 2' DIA. W/ TYP. 24 FRAME & GRATE STA. 109+54.9, 30' LT T.G. 748.59 AT EOP INV. (OUT) 745.57
- 6 CB, TYP. A, 4' DIA. W/ TYP. 8 GRATE STA. 109+54.9, 37.6' LT RIM 748.41 INV. (IN) S 745.39 INV. (IN) W 743.42 INV. (OUT) E 743.42
- 7 CB, TYP. C, 2' DIA. W/ TYP. 24 FRAME & GRATE STA. 110+96, 30.2' LT T.G. 748.29 AT EOP INV. (OUT) 745.12
- 8 CB, TYP. A, 4' DIA. W/ TYP. 8 GRATE STA. 110+96, 43.1' LT RIM 747.61 INV. (IN) S 744.60 INV. (IN) W 741.90 INV. (OUT) E 741.90
- 9 CB, TYP. C, 2' DIA. W/ TYP. 24 FRAME & GRATE STA. 112+99.4, 36.0' LT T.G. 747.54 AT EOP INV. (OUT) 744.13
- 10 MH, TYP. A, 6' DIA. W/ TYP. 1 FRAME & CL STA. 113+05, 44.5' LT (CENTER MH) RIM 747.80 INV. (IN) SW 744.00 INV. (IN) S 738.90 INV. (IN) W 738.90 INV. (OUT) E 738.90
- 11 MH, TYP. A, 4' DIA. W/ TYP. 1 FRAME & CL STA. 113+93, 45.0' LT (CENTER MH) RIM 746.80 INV. (IN) 738.72 INV. (OUT) 738.72
- 12 MH, T-A, 4' DIA. W/ T-1 F C.L. STA. 115+10, 37.7' LT RIM 745.50 INV. (IN) S 742.50 INV. (IN) W 738.50 INV. (OUT) N 738.50
- 13 CB, TYP. C, 2' DIA. W/ TYP. 1 FRAME OPEN LID STA. 115+10, 25.3' LT T.G. 747.27 AT EOP INV. (OUT) 742.98
- 14 CB, TYP. A, 4' DIA. W/ TYP. 8 GRATE STA. 201+89, 30.9' RT RIM 746.21 INV. (OUT) 742.19
- 15 INLET, T-A, 2' DIA. W/ TYP. 1 FRAME OPEN LID STA. 202+22.5, 18.0' RT (EOP) T.G. 745.77 AT EOP INV. (OUT) 741.23
- 16 MH, TYP. A, 4' DIA. W/ TYP. 1 FRAME & CL STA. 202+22, 14.7' RT (CENTER MH) RIM 745.90 INV. (IN) S 741.84 INV. (IN) SE 741.18 INV. (OUT) NW 741.18
- 17 EXIST. INLET TO BE ADJUSTED W/ NEW TYP. 1 FRAME & CL PROP. RIM 747.04 STA. 202+21 EXIST. INV. (IN) 740.50 EXIST. INV. (OUT) 740.50
- 18 INLET, T-A, 2' DIA. W/ TYP. 8 GRATE STA. 201+26, 30.6' LT RIM 747.23 INV. (OUT) 744.00
- 19 MH, T-A, 4' DIA. W/ T-1 F C.L. STA. 201+29, 24.3' LT (CENTER MH) RIM 747.85 INV. (IN) NE 739.86 INV. (OUT) SW 739.86 INV. (IN) NW 743.93
- 20 MH, T-A, 4' DIA. W/ T-1 F C.L. STA. 200+85, 31.8' LT (CENTER MH) RIM 747.60 INV. (IN) NE 739.68 INV. (OUT) SW 739.68 INV. (IN) SE 743.34
- 21 INLET, T-A, 2' DIA. W/ T-24 F&G STA. 200+85, 18' LT (EOP) T.G. 747.47 AT EOP INV. (OUT) 743.47
- 22 INLET, T-A, 2' DIA. W/ T-24 F&G STA. 204+50, 18.0' LT (EOP) T.G. 749.11 AT EOP INV. (OUT) 746.11
- 23 MH, T-A, 4' DIA. W/ T-1 F C.L. STA. 204+50, 24.9' LT (CENTER MH) RIM 749.58 INV. (IN) SE 746.05 INV. (OUT) SW 744.08
- 24 INLET, T-A, 2' DIA. W/ T-24 F&G STA. 203+50, 18.0' LT (EOP) T.G. 747.33 AT EOP INV. (OUT) 744.33
- 25 CB, TYP. A, 4' DIA. W/ TYP. 1 FRAME & CL STA. 203+50, 25.3' LT RIM 747.81 INV. (IN) SE 744.27 INV. (IN) NE 742.43 INV. (OUT) SW 742.43
- 26 EXIST. MH TO BE ADJUSTED STA. 202+21, 24.3' LT PROP. RIM 747.14 APPROX. INV. 740.27
- 27 CONCRETE END SECTION, STD. 542001, 24", 1:2 STA. 115+10, 25.4' LT INV. 738.48
- 28 EXIST. INLET STA. 203+32, 25.2' LT EXIST. RIM 746.44 REPLACE WITH TYP. 1 FRAME & CL INV. NW 743.74 INV. NE & SW 742.14
- 29 CONCRETE END SECTION, STD. 542001, 24", 1:2 STA. 113+05, 34.1' RT INV. 739.72
- 30 12" CONCRETE FLARED END SECTION STA. 105+82, 32.8' LT INV. 745.19
- 31 12" CONCRETE FLARED END SECTION STA. 106+22, 34.0' LT INV. 745.39
- 32 15" CONCRETE FLARED END SECTION STA. 107+20, 31.1' RT INV. 744.94
- 33 15" CONCRETE FLARED END SECTION STA. 107+52, 30.7' RT INV. 744.76
- 34 15" CONCRETE FLARED END SECTION STA. 110+35, 29.8' RT INV. 743.74
- 35 15" CONCRETE FLARED END SECTION STA. 110+67, 30.2' RT INV. 743.58

FILE NAME =	USER NAME = kalorm	DESIGNED -	REVISED - RK - 3/15/2021
p:\planroom.dot\illinois.gov\PIDOT\Documents\IDOT Offices\District 1\Projects\P171909\Drawn\Design\P171909-sht-details.dgn		CHECKED -	REVISED -
PLOT SCALE = 100.0000' / in.		DATE -	REVISED -
PLOT DATE = 3/14/2021			

**STATE OF ILLINOIS
DEPARTMENT OF TRANSPORTATION**

**DRAINAGE STRUCTURES AND PIPE TABLE
IL 173 AT NORTH LAKE AVENUE**

SCALE: N.T.S. SHEET NO. 2 OF 2 SHEETS STA. TO STA.

F.A.P. RTE.	SECTION	COUNTY	TOTAL SHEETS	SHEET NO.
303	(134&134)XIN	LAKE	129	57
FED. ROAD DIST. NO. 1 ILLINOIS				CONTRACT NO. 60V39

LONGITUDINAL PIPE UNDERDRAIN TABLE									
LOCATION	STATION - STATION	O/S (FT)	DIAMETER (IN)	PIPE UNDERDRAINS TYPE	LENGTH (FT)	WEST OUTLET	EAST OUTLET	SOUTH OUTLET	NORTH OUTLET
IL 173	105+07.7 - 106+42	VAR. LT	4	TYPE 2	134.3	CLOSED END	DITCH		
IL 173	106+42 - 107+38.7	VAR. LT	4	TYPE 2	96.7	DITCH	CLOSED END		
IL 173	107+50 - 108+50	VAR. LT	4	TYPE 2	100.0	△ ₂	△ ₄		
IL 173	108+50 - 109+54.9	VAR. LT	4	TYPE 2	104.9	△ ₄	△ ₆		
IL 173	109+54.9 - 110+96	33.0 LT	4	TYPE 2	141.1	△ ₆	△ ₈		
IL 173	110+96 - 113+05	40.0 LT	4	TYPE 2	209.0	△ ₈	△ ₁₀		
IL 173	112+99.4 - 115+10	39.0 LT	4	TYPE 2	210.6	△ ₉	△ ₁₃		
IL 173	115+10 - 115+50	VAR. LT	4	TYPE 2	40.0	△ ₁₃	DITCH		
NORTH LAKE AVE.	203+50.0 - 204+50	21.0 LT	4	TYPE 2	100.0			△ ₂₅	△ ₂₃
NORTH LAKE AVE.	204+50 - 206+09.4	VAR. LT	4	TYPE 2	159.4			△ ₂₃	CLOSED END
NORTH LAKE AVE.	200+80.0 - 202+22.5	VAR. RT	4	TYPE 2	142.5			CLOSED END	△ ₁₅
NORTH LAKE AVE.	202+22.5 - 206+09.5	21.0 RT	4	TYPE 2	387.0			△ ₁₅	CLOSED END

PIPE UNDERDRAIN NOTES:

LONGITUDINAL UNDERDRAINS MUST BE PLACED UNDER THE OUTSIDE EDGES OF THE NEW PAVEMENT AND AT THE BASE OF THE EXISTING SLOPES TO BE WIDENED AT APPROXIMATELY THESE LOCATIONS.

FILE NAME =	USER NAME = kalorm	DESIGNED -	REVISED -	STATE OF ILLINOIS DEPARTMENT OF TRANSPORTATION	PIPE UNDERDRAIN TABLE IL 173 AT NORTH LAKE AVENUE			F.A.P. RTE.	SECTION	COUNTY	TOTAL SHEETS	SHEET NO.
p:\plnroom.dot.illinois.gov\PIDOT\Documents\IDOT Offices\District 1\Projects\PI171909\Drawings\Design\PI171909-sht-details.dgn	DRAWN -	REVISED -	303					(134&134XIN	LAKE	129	58	
PLOT SCALE = 100.0000' / in.	CHECKED -	REVISED -	SCALE: N.T.S.			SHEET NO. 2 OF 2 SHEETS	STA.	TO STA.	CONTRACT NO. 60V39			
PLOT DATE = 1/27/2021	DATE -	REVISED -	FED. ROAD DIST. NO. 1 ILLINOIS									

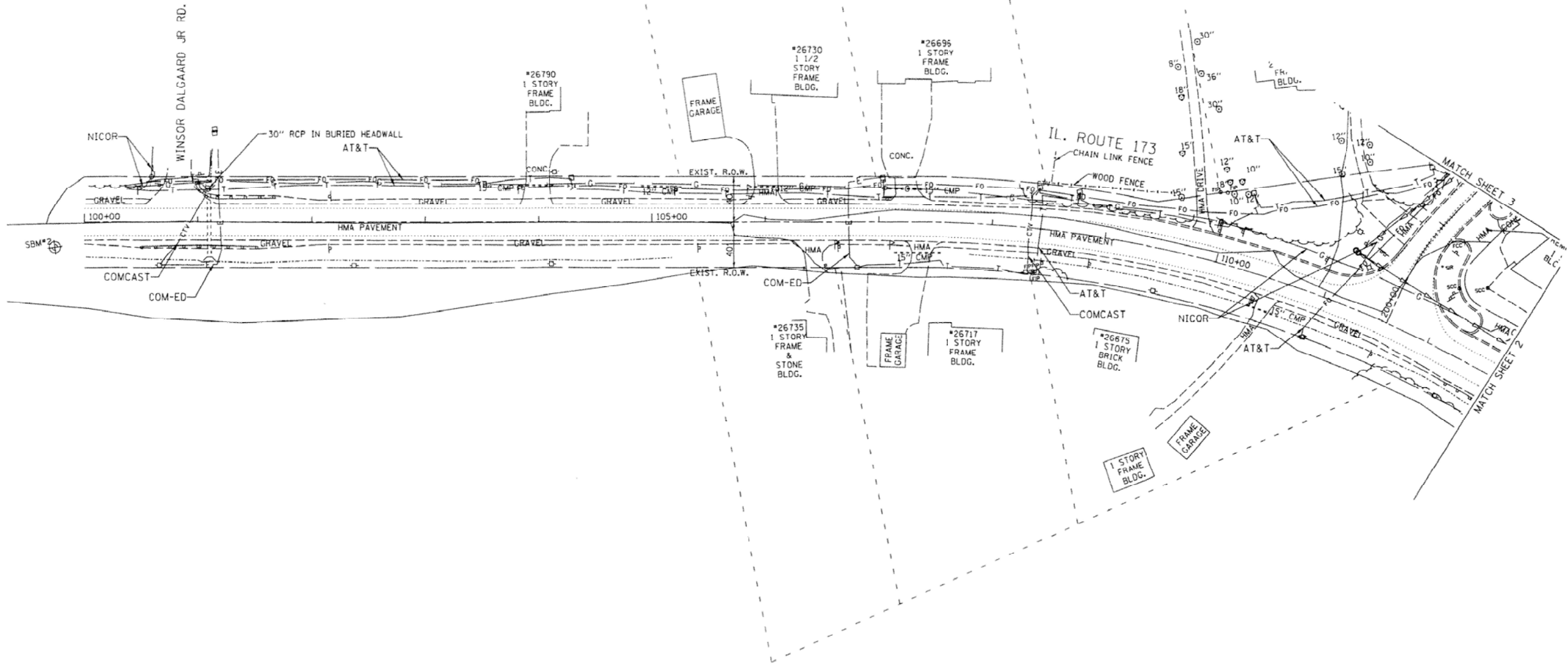

— A — A —	AERIAL
— O — O —	UNKNOWN
— CTV — CTV —	OIL
— T — T —	CABLE TV
— G — G —	TELEPHONE
— E — E —	GAS
— W — W —	ELECTRIC
— FO — FO —	WATER
— FO — FO —	FORCE MAIN
— FO — FO —	FIBER OPTIC
—	END OF INFORMATION
⊕	TBE TEST HOLE

Utility Quality Level "A" : Visually Verified Test Hole
 Utility Quality Level "B" : Designating/non Visually Verified Test Hole
 Utility Quality Level "C" : Research with Survey
 Utility Quality Level "D" : Records Research

UTILITY OWNERS	
AT&T = FIBER OPTIC	
AT&T = TELEPHONE	
COM-ED = ELECTRIC	
COMCAST = CABLE TV	
NICOR = GAS	

Utilities shown on these plans as depicted in the legend have been investigated by Cardno TBE in accordance with SUE Industry Standards. All other information shown has been provided to Cardno TBE by others. Cardno TBE's "B" SUE field investigation was performed 5/20/13 through 5/31/13. Changes to utilities after 5/31/13 may have been made and therefore may result in variances from this plan. Consideration should be given to updating this plan if deemed advisable prior to final design and construction.

ALL UTILITIES SHOWN QUALITY LEVEL "B" UNLESS NOTED OTHERWISE.

Kenneth F. Slaninka, Jr.
 6/1/13
 License expires 11-30-13

TBE Job No. IL09510533
 SUE Plan Page: 1 of 3

F.A. RTE.	SECTION	COUNTY	TOTAL SHEETS	SHEET NO.
	(134 & 134X) N	LaKe	129	59

Contract No. 60V39
 FED. ROAD DIST. NO. [] ILLINOIS 100T Project No.

DESIGNED LP	REVISED
DRAWN SRK	REVISED
CHECKED KFS	REVISED
DATE 6/5/13	REVISED

STATE OF ILLINOIS
 DEPARTMENT OF TRANSPORTATION

IL 173 at North Lake Avenue
 Antioch, Illinois

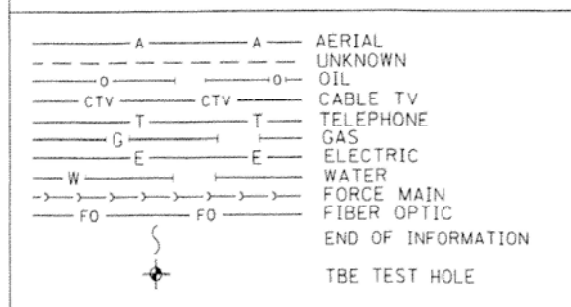
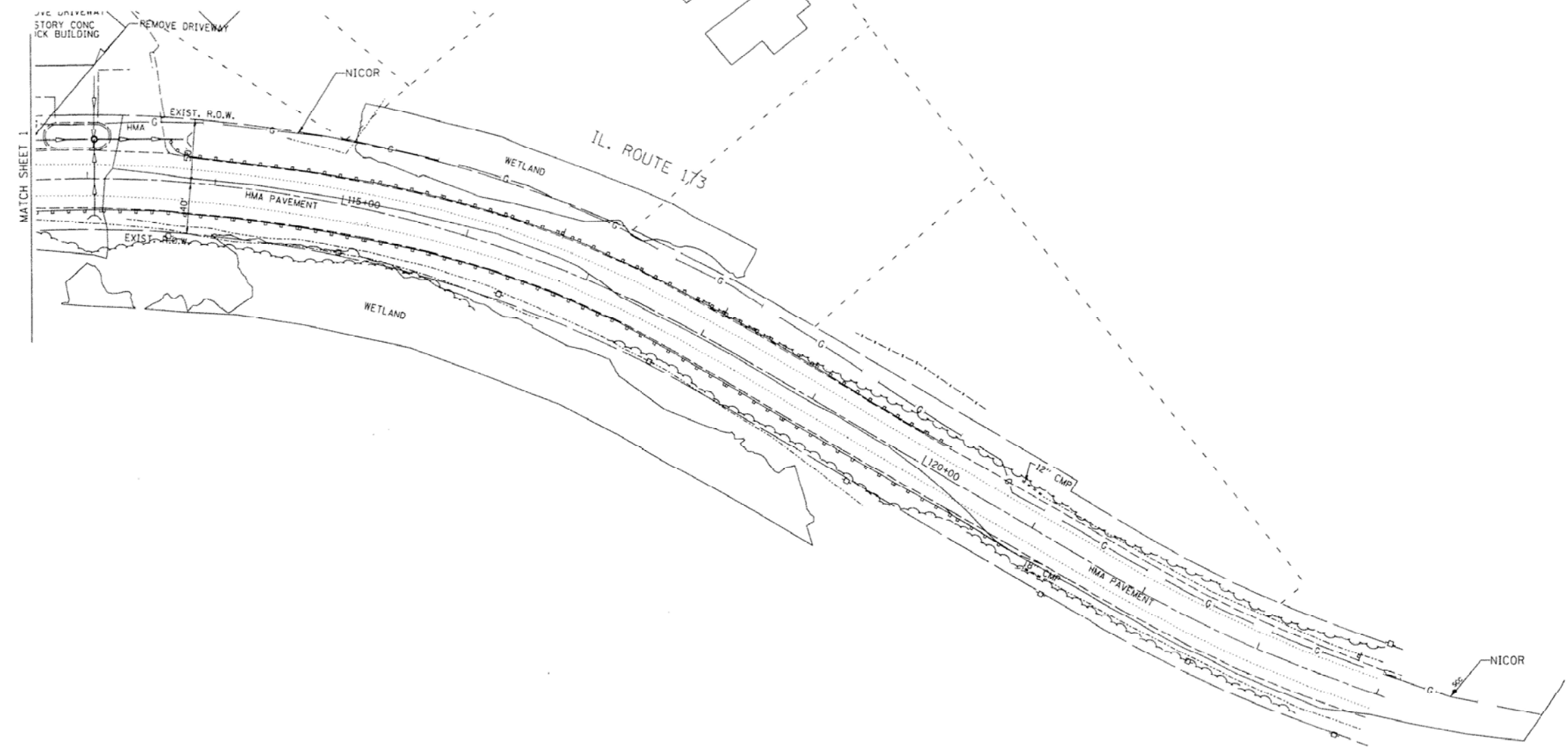
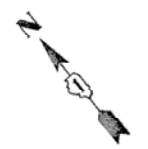

UTILITY OWNERS	
AT&T = FIBER OPTIC	
AT&T = TELEPHONE	
COM-ED = ELECTRIC	
COMCAST = CABLE TV	
NICOR = GAS	

Utilities shown on these plans as depicted in the legend have been investigated by Cardno TBE in accordance with SUE Industry Standards. All other information shown has been provided to Cardno TBE by others. Cardno TBE's OL "B" SUE field investigation was performed 5/20/13 through 5/31/13. Changes to utilities after 5/31/13 may have been made and therefore may result in variances from this plan. Consideration should be given to updating this plan if deemed advisable prior to final design and construction.

ALL UTILITIES SHOWN QUALITY LEVEL "B" UNLESS NOTED OTHERWISE.

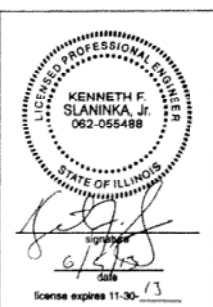

TBE Job No. IL09510533
SUE Plan Page: 2 of 3

Utility Quality Level "A": Visually Verified Test Hole
 Utility Quality Level "B": Designating/non Visually Verified Test Hole
 Utility Quality Level "C": Research with Survey
 Utility Quality Level "D": Records Research

DESIGNED LP	REVISED
DRAWN SRK	REVISED
CHECKED KFS	REVISED
DATE 6/5/13	REVISED

STATE OF ILLINOIS
DEPARTMENT OF TRANSPORTATION

IL 173 at North Lake Avenue
Antioch, Illinois

F.A. RTE.	SECTION	COUNTY	TOTAL SHEETS	SHEET NO.
	(134 & 134X) N	Lake	129	60

Contract No. 60V39
 FED. ROAD DIST. NO. - [ILLINOIS] DOT Project No.



— A — A —	AERIAL
— O — O —	UNKNOWN
— CTV — CTV —	OIL
— T — T —	CABLE TV
— G — G —	TELEPHONE
— E — E —	GAS
— W — W —	ELECTRIC
— FO — FO —	WATER
	FORCE MAIN
	FIBER OPTIC
	END OF INFORMATION
⊙	TBE TEST HOLE

UTILITY OWNERS	
AT&T	= FIBER OPTIC
AT&T	= TELEPHONE
COM-ED	= ELECTRIC
COMCAST	= CABLE TV
NICOR	= GAS

Utilities shown on these plans as depicted in the legend have been investigated by Cardno TBE in accordance with SUE Industry Standards. No other information shown has been provided to Cardno TBE by others. Cardno TBE's DL "B" SUE field investigation was performed 5/20/13 through 5/31/13. Changes to utilities after 5/31/13 may have been made and therefore may result in variances from this plan. Consideration should be given to updating this plan if deemed advisable prior to final design and construction.

ALL UTILITIES SHOWN QUALITY LEVEL "B" UNLESS NOTED OTHERWISE.

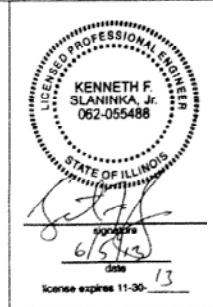

TBE Job No. IL09510533
SUE Plan Page: 3 of 3

Utility Quality Level "A" : Visually Verified Test Hole
 Utility Quality Level "B" : Designating/Non Visually Verified Test Hole
 Utility Quality Level "C" : Research with Survey
 Utility Quality Level "D" : Records Research

DESIGNED	LP	REVISED
DRAWN	SRK	REVISED
CHECKED	KFS	REVISED
DATE	6/5/13	REVISED

STATE OF ILLINOIS
DEPARTMENT OF TRANSPORTATION

IL 173 at North Lake Avenue
Antioch, Illinois

F.A. RTE.	SECTION	COUNTY	TOTAL SHEETS	SHEET NO.
	1134 & 134X1 N	Lake	129	61
FED. ROAD DIST. NO.			ILLINOIS DOT Project No.	

PART OF SEC. 11, T46N, R9E OF THE 3RD P.M., LAKE COUNTY, ILLINOIS

PARCEL NO.	OWNER	TOTAL HOLDINGS (ACRES)	PART TAKEN (ACRES)	PREVIOUSLY DEDICATED (ACRES)	REMAINDER (ACRES)	EASEMENT AREA (ACRES) (SQ. FT.)	PERMANENT INDEX NUMBER	PURPOSE OF EASEMENT	ACQUIRED BY
1KK0001-A	PAUL WACZAK	0.492 AC	0.011 AC		0.433 AC		01-11-315-001	N/A	
1KK0001-B			0.048 AC						
1KK0002TE	JOSH MARCOMB	1.306 AC				0.005 AC 222 SQ.FT.	01-11-300-032	TEMPORARY	
1KK0003TE	JUDITH E. MULLER	1.472 AC				0.006 AC 279 SQ.FT.	01-11-300-029	TEMPORARY	

STATION & OFFSET	ILLINOIS STATE PLANE COORDINATES
PARCEL 1KK0001-A	
112+24.79-50.00' LEFT	N 2116128.15 E 1033083.22
112+02.20-80.72' LEFT	N 2116167.12 E 1033081.22
112+05.89-95.71' LEFT	N 2116177.18 E 1033093.04
PARCEL 1KK0001-B	
114+92.82-50.00' LEFT	N 2115935.40 E 1033287.05
113+10.70-50.00' LEFT	N 2116072.38 E 1033154.06
113+10.70-65.00' LEFT	N 2116083.76 E 1033163.84
113+70.57-65.00' LEFT	N 2116040.79 E 1033210.95
113+70.57-60.00' LEFT	N 2116037.20 E 1033207.47
114+65.20-60.00' LEFT	N 2115964.19 E 1033276.11
PARCEL 1KK0002TE	
108+47.64+40.00' LEFT	N 2116284.92 E 1032724.11
108+04.36+40.00' LEFT	N 2116295.07 E 1032680.27
108+04.36+45.00' LEFT	N 2116299.96 E 1032681.30
108+46.36+45.00' LEFT	N 2116290.09 E 1032724.04
PARCEL 1KK0003TE	
108+47.64+40.00' LEFT	N 2116284.92 E 1032724.11
108+46.36+45.00' LEFT	N 2116290.09 E 1032724.04
109+00.54+45.00' LEFT	N 2116274.73 E 1032778.51
109+00.54+40.00' LEFT	N 2116269.96 E 1032777.03

CURVE	RADIUS	LENGTH	CHORD	CHORD BEARING	DELTA
C1	1055.60	191.18'	190.91'	N44°09'09"W	10°22'36"
C2	1070.60	63.77'	63.76'	S47°38'04"E	3°24'46"
C3	1065.60	100.25'	100.21'	S43°13'59"E	5°23'25"
C4	25.00	44.77'	39.02'	N 2°56'23"W	102°35'51"
C5	360.78	15.51'	15.51'	N49°35'26"E	2°27'51"
C6	1050.60	56.60'	56.60'	S74°15'14"E	3°05'13"
C7	1045.60	55.00'	55.00'	N74°13'03"W	3°00'50"
C8	1045.60	45.00'	45.00'	N38°53'27"W	2°23'59"
C9	1050.60	43.87'	43.87'	S76°59'22"E	2°23'34"

LINE	BEARING	LENGTH
L1	N40°39'33"E	15.00'
L2	S44°04'19"W	5.00'
L3	S20°48'17"E	30.80'
L4	S11°19'06"W	50.00'
L5	S17°17'22"W	5.00'
L6	N 0°42'51"W	5.18'
L7	N11°48'39"E	5.00'

DATE	BY	REVISION

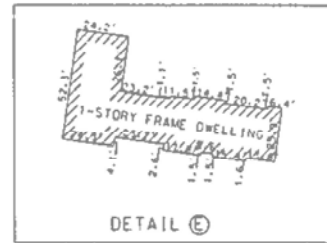
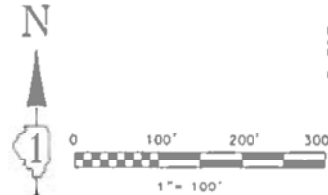
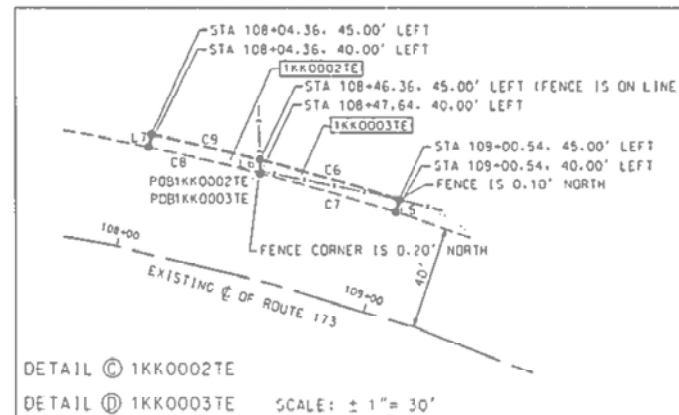
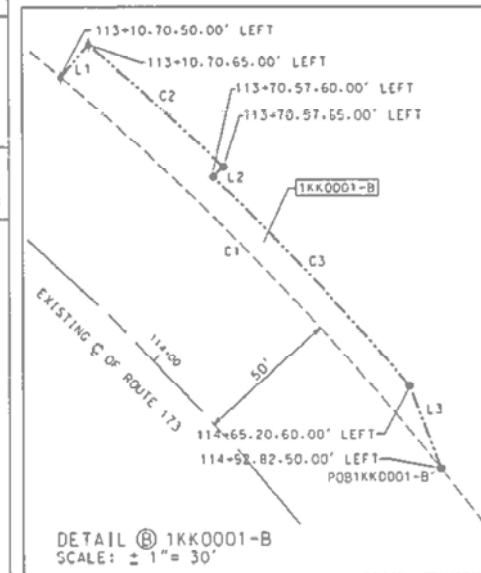

F.A.P. RTE.	SECTION	COUNTY	TOTAL SHEETS	SHEET NO.
ILL. RTE 173	AT LAKE AVE.	LAKE	2	2

FED. ROAD DIST. NO. 1 ILLINOIS FED. AID PROJECT

LEGEND

SECTION CORNER
QUARTER SECTION CORNER

SECTION LINE
QUARTER SECTION LINE
QUARTER-QUARTER SECTION LINE
PLATTED LOT LINE
PROPERTY IDEED LINE

APPARENT PROPERTY LINE
CENTERLINE
EXISTING RIGHT OF WAY LINE
PROPOSED RIGHT OF WAY LINE
PROPOSED EASEMENT
MEASURED DIMENSION
COMPUTED DIMENSION
RECORD DATA

EXISTING BUILDING

IRON ROD SET
IRON PIPE OR ROD FOUND
CUT CROSS FOUND OR SET

THESE STAKES, REFERENCE FOUND OR SET MONUMENTATION:
12 IRON ROD FLUSHED WITH GROUND TO THE FOUND IRON STAKE, IDENTIFIED BY COLORED PLASTIC CAP BEARING SURVEYORS REGISTRATION NUMBER.
13 IRON ROD FLUSHED WITH GROUND TO THE FOUND IRON STAKE, IDENTIFIED BY COLORED PLASTIC CAP BEARING SURVEYORS REGISTRATION NUMBER.
14 THESE STAKES, IN CULTIVATED AREAS, REFERENCE FOUND OR SET MONUMENTATION, BURIED 5/8 INCH IRON ROD 20 INCHES BELOW GROUND TO THE FOUND IRON STAKE, IDENTIFIED BY COLORED PLASTIC CAP BEARING SURVEYORS REGISTRATION NUMBER.

STAKING OF PROPOSED RIGHT OF WAY, SET DIVISION OF HIGHWAYS SURVEY MARKER TO MONUMENT THE POSITION SHOWN, IDENTIFIED BY INSCRIPTION DATA AND SURVEYORS REGISTRATION NUMBER.

STAKING OR PROPOSED RIGHT OF WAY IN CULTIVATED AREAS, BURIED 5/8 INCH METAL ROD 20 INCHES BELOW GROUND TO MARK FUTURE SURVEY MARKER POSITION, IDENTIFIED BY COLOR PLASTIC CAP BEARING SURVEYORS REGISTRATION NUMBER.

PERMANENT SURVEY MARKER, I D O T STD. 2135 I TO BE SET BY OTHERS!

RIGHT OF WAY STAKING PROPOSED TO BE SET.
LIGHT STANDARD
POINT OF BEGINNING
POINT OF COMMENCEMENT

EAST LINE OF THE SE QUARTER OF THE SW QUARTER SECTION 11-46-9

CHASE SUBDIVISION
DOC. # 1279398
DATED SEPT. 29, 1965

ROGERS SUBDIVISION
DOCUMENT # 954810
DATED JUNE 22, 1957

ILLINOIS ROUTE 173
& CURVE DATA
DELTA = 62°51' (62°51')
R = 1005.60' (1005.6')
L = 1103.08' (1102.63')
Lc = 1048.60'
e = 172.85' (173.05')

WALTER S. DOUGLAS DIVISION
DOC. # 944522
DATED MARCH 22, 1957

STATE OF ILLINOIS
COUNTY OF COOK

I, MANUEL E. PALMA, DO HEREBY DECLARE THAT I HAVE SURVEYED THE PLAT OF HIGHWAYS SHOWN HEREON IN SECTION 11, TOWNSHIP 46 NORTH, RANGE 9 EAST OF THE THIRD PRINCIPAL MERIDIAN, IN LAKE COUNTY, ILLINOIS; THAT THE SURVEY IS TRUE AND COMPLETE AS SHOWN TO THE BEST OF MY KNOWLEDGE AND BELIEF; THAT THE PLAT CORRECTLY REPRESENTS SAID SURVEY; THAT ALL MONUMENTS FOUND AND ESTABLISHED ARE OF PERMANENT QUALITY AND OCCUPY THE POSITIONS SHOWN THEREON AND THAT THE MONUMENTS ARE SUFFICIENT TO ENABLE THE SURVEY TO BE RETRACED, MADE FOR THE DEPARTMENT OF TRANSPORTATION, STATE OF ILLINOIS.

DATED AT CHICAGO, ILLINOIS THIS 5TH DAY OF JUNE, A.D., 2018.

Manuel E. Palma
MANUEL E. PALMA
PROFESSIONAL LAND SURVEYOR
2135
ILLINOIS

TECMA ASSOCIATES, INC.
ENGINEERS SURVEYORS CONSTRUCTION MANAGERS
5519 N. CLUMBERLAND AVENUE, SUITE 1010
CHICAGO, ILLINOIS 60656
PHONE: 773-783-5555
FAX: 773-783-5577

RECEIVED
AUG 07 2018
PLATS & LEGALS

Manhard CONSULTING LTD
PLAT OF HIGHWAYS
STATE OF ILLINOIS
DEPARTMENT OF TRANSPORTATION
ILLINOIS ROUTE 173
SECTION: AT LAKE AVENUE LAKE COUNTY
PROJECT JOB NO. R-91-010-13
STATION 108+80 TO STATION 119+50
SCALE: AS NOTED SHEET 2 OF 2

BUREAU OF LAND ACQUISITION
201 WEST CENTER COURT
SCHAUMBURG, ILLINOIS 60196
AS DOCUMENT NO.

REVISION DATE	DESCRIPTION	INITIALS
6/5/2018	UPDATE PER NEW TITLE AND SET BOUNDARY CORNERS	MEP

F.A.P. RTE.	SECTION	COUNTY	TOTAL SHEETS	SHEET NO.
303	(134&134XN)	LAKE	129	62

CONTRACT NO. 60V39

PART OF SEC. 11, T46N, R9E OF THE 3RD P.M., LAKE COUNTY, ILLINOIS

F.A.P. RTE.	SECTION	COUNTY	TOTAL SHEETS	SHEET NO.
IL RTE 173	AT LAKE AVE.	LAKE	2	2
FED. ROAD DIST. NO. 1		ILLINOIS	FED. AID PROJECT	

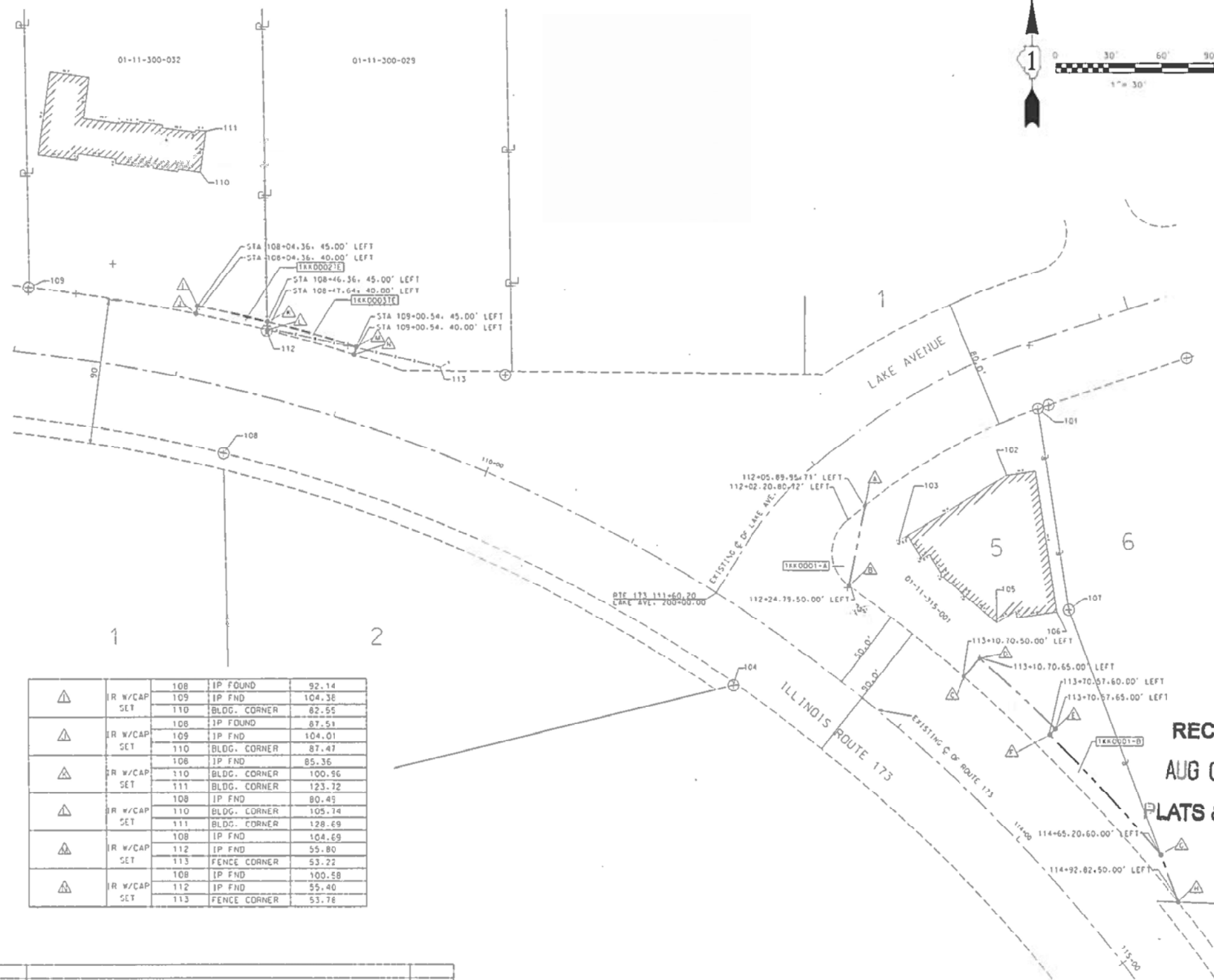

ROW	MONUMENT	DESC.	REF. MARK	DESCRIPTION	DISTANCE (FT)
△	PK NAIL SET		101	SPIKE FOUND	122.74
			102	BLDG. CORNER	89.72
			103	BLDG. CORNER	30.05
△	PK NAIL SET		103	BLDG. CORNER	41.34
			104	IP FOUND	94.72
			105	BLDG. CORNER	94.14
△	PK NAIL SET		103	BLDG. CORNER	92.43
			104	BLDG. CORNER	143.22
			105	BLDG. CORNER	39.05
△	PK NAIL SET		104	IP FOUND	153.82
			105	BLDG. CORNER	24.34
			106	BLDG. CORNER	55.91
△	IR W/CAP SET		104	IP FOUND	201.71
			105	BLDG. CORNER	74.27
			106	BLDG. CORNER	11.74
△	IR W/CAP SET		104	IP FOUND	198.77
			105	BLDG. CORNER	75.06
			106	BLDG. CORNER	75.45
△	IR W/CAP SET		104	IP FOUND	284.68
			105	BLDG. CORNER	174.38
			106	BLDG. CORNER	162.01
△	IR W/CAP SET		104	IP FOUND	305.97
			105	BLDG. CORNER	204.04
			107	IR FND	190.83

MONUMENT CORNER REFERENCE TABLE

△	IR W/CAP SET	108	IP FOUND	92.14
		109	IP FND	104.38
		110	BLDG. CORNER	82.55
△	IR W/CAP SET	108	IP FOUND	87.51
		109	IP FND	104.01
		110	BLDG. CORNER	87.47
△	IR W/CAP SET	110	BLDG. CORNER	100.96
		111	BLDG. CORNER	123.72
		108	IP FND	80.45
△	IR W/CAP SET	110	BLDG. CORNER	105.74
		111	BLDG. CORNER	128.69
		108	IP FND	104.69
△	IR W/CAP SET	112	IP FND	55.80
		113	FENCE CORNER	53.22
		108	IP FND	100.58
△	IR W/CAP SET	112	IP FND	55.40
		113	FENCE CORNER	53.78

DATE	BY	DESCRIPTION

REVISION DATE	DESCRIPTION	INITIALS
6/5/2018	UPDATE PER NEW TITLE AND SET BOUNDARY CORNERS	MEP

RECEIVED
AUG 07 2018
PLATS & LEGALS

TECMA ASSOCIATES, INC.
ENGINEERS SURVEYORS CONSTRUCTION MANAGERS
5515 N. CUMBERLAND AVENUE, SUITE 1010
CHICAGO, ILLINOIS 60658
PHONE: 773-763-6555
FAX: 773-763-5577

Manhard CONSULTING LTD

PLAT OF HIGHWAYS
STATE OF ILLINOIS
DEPARTMENT OF TRANSPORTATION
ILLINOIS ROUTE 173
SECTION: AT LAKE AVENUE LAKE COUNTY
PROJECT JOB NO. R-91-810-13
STATION 108+00 TO STATION 119+50
SCALE: AS NOTED SHEET ___ OF ___

BUREAU OF LAND ACQUISITION
201 WEST CENTER COURT
SCHAMBOURG, ILLINOIS 60196
AS DOCUMENT NO.

F.A.P. RTE.	SECTION	COUNTY	TOTAL SHEETS	SHEET NO.
303	(134&134X)N	LAKE	129	63

CONTRACT NO. 60V39

NOTES:

1. PROVIDE PAVEMENT MARKINGS IN ACCORDANCE WITH DISTRICT ONE DETAIL TC-13 AND LCDOT STANDARDS.
2. ALL RAISED REFLECTIVE PAVEMENT MARKERS SHALL BE PLACED IN ACCORDANCE WITH "TYPICAL APPLICATIONS RAISED REFLECTIVE PAVEMENT MARKERS (SNOW PLOW RESISTANT)" STANDARD TC-11 AND LCDOT STANDARDS.
3. RECESSED REFLECTIVE PAVEMENT MARKERS WHITE-LANE MARKERS SHALL BE WHITE/RED.
4. THE RESIDENT ENGINEER SHALL VERIFY THE LOCATIONS OF ALL EXISTING PAVEMENT MARKINGS PRIOR TO MILLING OR RESURFACING.
5. GROOVING THERMOPLASTIC PAVEMENT MARKING SHALL BE USED ON NORTH LAKE AVENUE

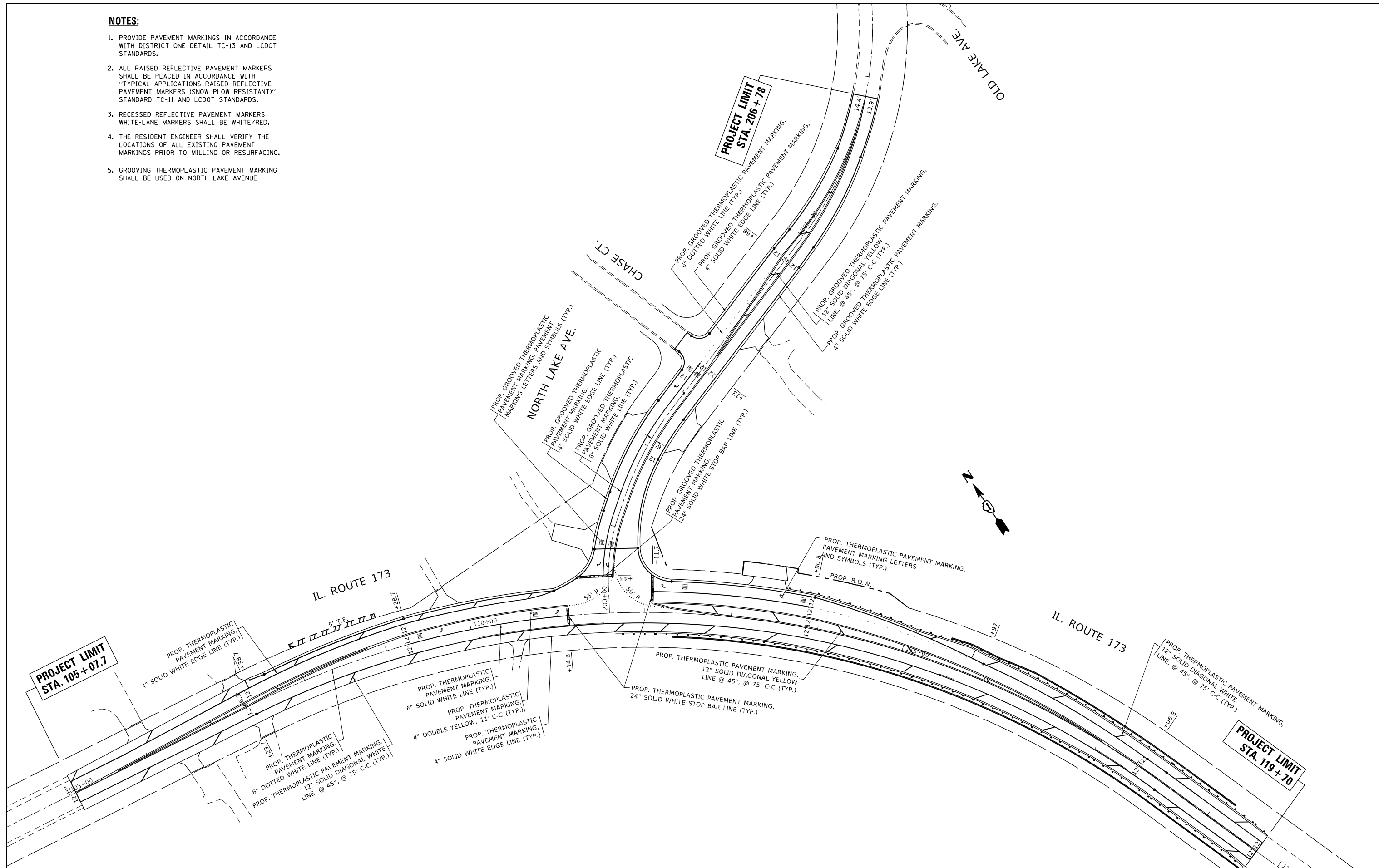

FILE NAME = p:\plnroom.dot\illinois.gov\PIDOT\Documents\IDOT Offices\District 1\Projects\P171909\DRAWING\CAD\sheets\P171909-sh1-pmk.dgn	USER NAME = kalorm	DESIGNED -	REVISED - RK - 3/15/2021	<p align="center">STATE OF ILLINOIS DEPARTMENT OF TRANSPORTATION</p>	<p align="center">PAVEMENT MARKING PLAN IL. ROUTE 173 AT NORTH LAKE AVE.</p>	F.A.P. RTE.	SECTION	COUNTY	TOTAL SHEETS	SHEET NO.
	PLOT SCALE = 100.0000' / in.	CHECKED -	REVISED -			303	(134&134)XN	LAKE	129	64
Default	PLOT DATE = 3/14/2021	DATE -	REVISED -	SCALE: 1"=50'		SHEET OF SHEETS STA. TO STA.		CONTRACT NO. 60V39		
ILLINOIS FED. AID PROJECT										

ALL SIGNAL WARNING AHEAD SIGN ASSEMBLIES SHALL BE INSTALLED AND VISIBLE TO TRAFFIC AT THE TIME OF THE NEW TRAFFIC SIGNAL ACTIVATION. THE "NEW" (W16-1P) SIGN & RED FLAGS SHALL BE REMOVED NO LATER THAN 6 MONTHS AFTER THE REGULATION HAS BEEN IN EFFECT.

NOTE: REFER TO SIGNAGE SCHEDULE

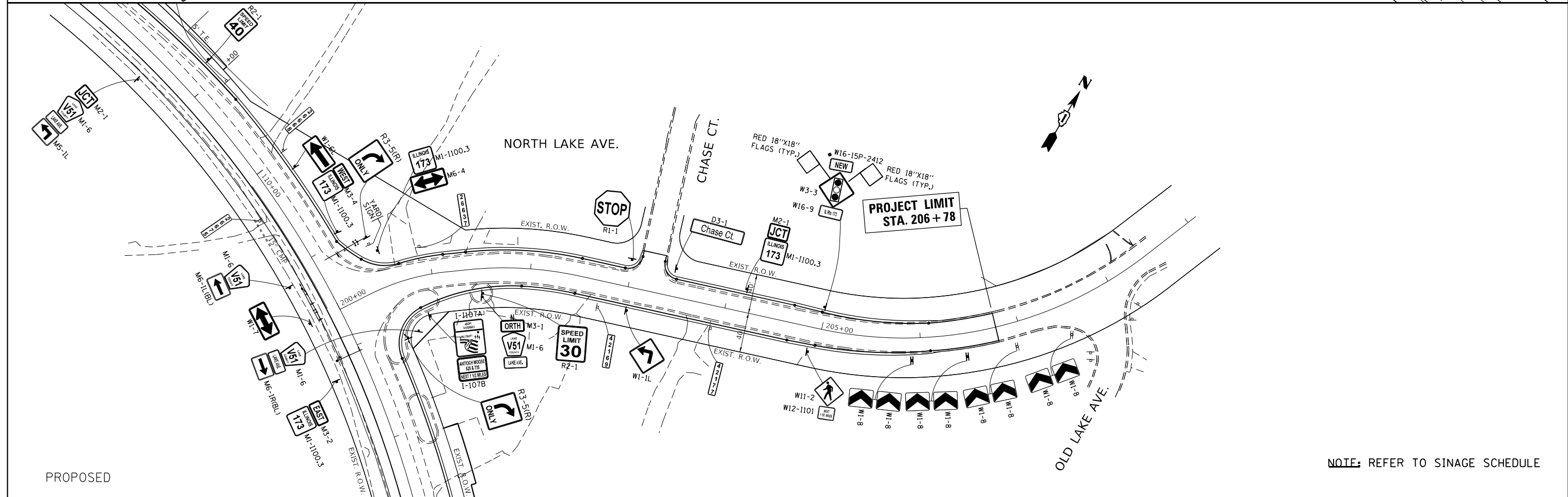
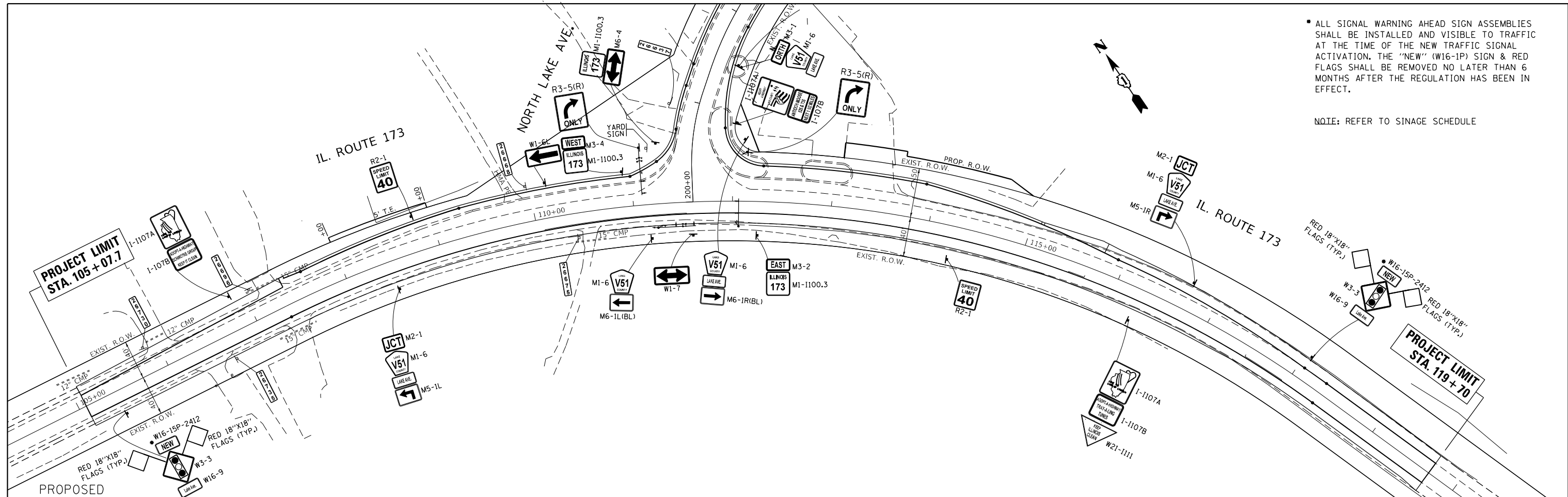

NOTE: REFER TO SIGNAGE SCHEDULE

FILE NAME =	USER NAME = kalorm	DESIGNED -	REVISED - RK - 3/15/2021	STATE OF ILLINOIS DEPARTMENT OF TRANSPORTATION	PROPOSED SIGNAGE IL. ROUTE 173 AT NORTH LAKE AVE.				F.A.P. RTE.	SECTION	COUNTY	TOTAL SHEETS	SHEET NO.
pw:\plnroom.dot.illinois.gov\PIDOT\Documents\IDOT Offices\District 1\Projects\P171909\Design\PI71909-sht-details.dgn		CHECKED -	REVISED -		303	(134&134XIN	LAKE	129	65				
Default	PLOT SCALE = 100.0000' / in.	DATE -	REVISED -		SCALE: 1"=50' SHEET OF SHEETS STA. TO STA.				CONTRACT NO. 60V39				
	PLOT DATE = 3/14/2021				ILLINOIS FED. AID PROJECT								

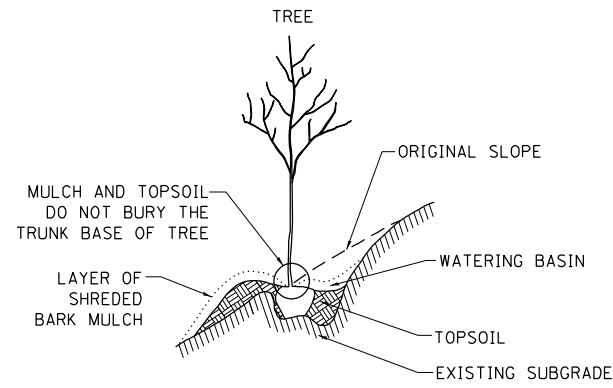
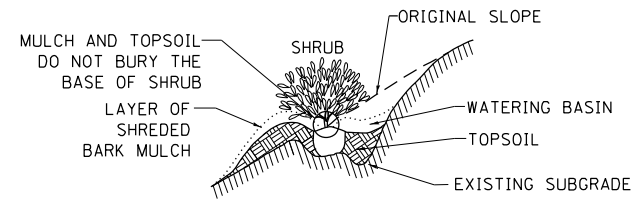

SHRUB AND TREE PLANTING DETAIL
DRAWN NOT TO SCALE

LEGEND

SEEDING CLASS 2A
FERTILIZER NUTRIENTS
EROSION CONTROL BLANKET

SEEDING CLASS 4 (MODIFIED)
EROSION CONTROL BLANKET

⊙ J = JUGLANS NIGRA, (BLACK WALNUT, 12 EA.)
TREES SHALL BE PLANTED 18' O.C. MIN. ON SLOPE
(SEE DETAIL)
LAYOUT TO BE DONE BY IDOT ROADSIDE DEVELOPMENT
UNIT. CONTRACTOR IS TO NOTIFY MELISSA DEL ROSARIO
(847)705-4391 72 HOURS PRIOR TO PLANTING.

- TREE AND SHRUB LOCATIONS ARE TENTATIVE. LOCATIONS MAY
BE ADJUSTED DUE TO FINAL GRADING TO ENSURE FOR THE
SUCCESSFUL ESTABLISHMENT OF PLANT MATERIALS.

- SHRUBS SHALL HAVE A MULCHED BED.

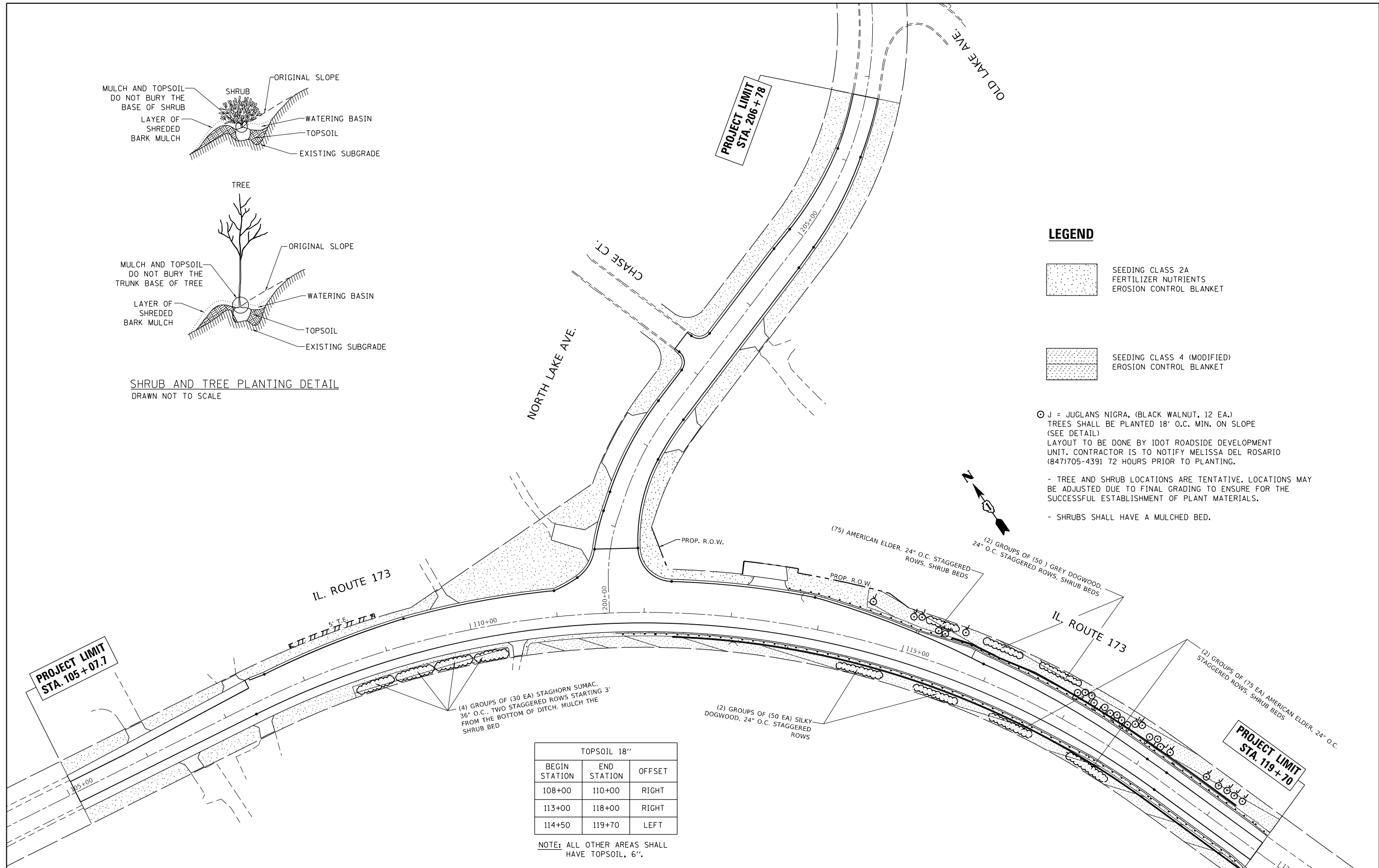

TOPSOIL 18"		
BEGIN STATION	END STATION	OFFSET
108+00	110+00	RIGHT
113+00	118+00	RIGHT
114+50	119+70	LEFT

NOTE: ALL OTHER AREAS SHALL
HAVE TOPSOIL, 6".

FILE NAME =	USER NAME = kalorm	DESIGNED -	REVISED - RK - 3/15/2021
pw:\planroom.dot.illinois.gov\PIDOT\Documents\IDOT Offices\District 1\Projects\P171909\CAD\Sheets\P171909-sht-landsap.dwg		DRAWN -	REVISED -
Default	PLOT SCALE = 100.0000' / in.	CHECKED -	REVISED -
	PLOT DATE = 3/14/2021	DATE -	REVISED -

**STATE OF ILLINOIS
DEPARTMENT OF TRANSPORTATION**

LANDSCAPING PLAN
IL. ROUTE 173 AT NORTH LAKE AVE.

SCALE: 1"=50' SHEET OF SHEETS STA. TO STA.

F.A.P. RTE.	SECTION	COUNTY	TOTAL SHEETS	SHEET NO.
303	(134&134X)N	LAKE	129	66
CONTRACT NO. 60V39				
ILLINOIS FED. AID PROJECT				

TRAFFIC SIGNAL LEGEND

(NOT TO SCALE)

ITEM	EXISTING	PROPOSED	ITEM	EXISTING	PROPOSED	ITEM	EXISTING	PROPOSED
CONTROLLER CABINET			HANDHOLE -SQUARE -ROUND	 	 	SIGNAL HEAD -(P) PROGRAMMABLE SIGNAL HEAD		
COMMUNICATION CABINET			HEAVY DUTY HANDHOLE -SQUARE -ROUND	 	 	SIGNAL HEAD WITH BACKPLATE -(P) PROGRAMMABLE SIGNAL HEAD -(RB) RETROREFLECTIVE BACKPLATE		
MASTER CONTROLLER			DOUBLE HANDHOLE			PEDESTRIAN SIGNAL HEAD AT RAILROAD INTERSECTIONS		
MASTER MASTER CONTROLLER			JUNCTION BOX			PEDESTRIAN SIGNAL HEAD WITH COUNTDOWN TIMER		
UNINTERRUPTABLE POWER SUPPLY			RAILROAD CANTILEVER MAST ARM			ILLUMINATED SIGN "NO LEFT TURN"/"NO RIGHT TURN"		
SERVICE INSTALLATION -(P) POLE MOUNTED			RAILROAD FLASHING SIGNAL			NUMBER OF CONDUCTORS, ELECTRIC CABLE NO. 14, UNLESS NOTED OTHERWISE. ALL DETECTOR LOOP CABLE TO BE SHIELDED		
SERVICE INSTALLATION -(G) GROUND MOUNTED -(GM) GROUND MOUNTED METERED	 	 	RAILROAD CROSSING GATE			GROUND CABLE IN CONDUIT, NO. 6 SOLID COPPER (GREEN)		
TELEPHONE CONNECTION			RAILROAD CROSSBUCK			ELECTRIC CABLE IN CONDUIT, TRACER NO. 14 1/C		
STEEL MAST ARM ASSEMBLY AND POLE			RAILROAD CONTROLLER CABINET			COAXIAL CABLE		
ALUMINUM MAST ARM ASSEMBLY AND POLE			UNDERGROUND CONDUIT (UC), GALVANIZED STEEL			VENDOR CABLE		
STEEL COMBINATION MAST ARM ASSEMBLY AND POLE WITH LUMINAIRE			TEMPORARY SPAN WIRE, TETHER WIRE, AND CABLE			COPPER INTERCONNECT CABLE, NO. 18, 3 PAIR TWISTED, SHIELDED		
SIGNAL POST -(BM) BARREL MOUNTED - TEMPORARY			SYSTEM ITEM	S	SP	FIBER OPTIC CABLE -NO. 62.5/125, MM12F -NO. 62.5/125, MM12F SM12F -NO. 62.5/125, MM12F SM24F		
WOOD POLE			INTERSECTION ITEM	I	IP	GROUND ROD -(C) CONTROLLER -(M) MAST ARM -(P) POST -(S) SERVICE		
GUY WIRE			REMOVE ITEM		R			
SIGNAL HEAD			RELOCATE ITEM		RL			
SIGNAL HEAD WITH BACKPLATE			ABANDON ITEM		A			
SIGNAL HEAD OPTICALLY PROGRAMMED			CONTROLLER CABINET AND FOUNDATION TO BE REMOVED		RCF			
FLASHER INSTALLATION -(FS) SOLAR POWERED	 	 	MAST ARM POLE AND FOUNDATION TO BE REMOVED		RMF			
PEDESTRIAN SIGNAL HEAD			SIGNAL POST AND FOUNDATION TO BE REMOVED		RPF			
PEDESTRIAN PUSH BUTTON -(APS) ACCESSIBLE PEDESTRIAN PUSH BUTTON			DETECTOR LOOP, TYPE I	 	 			
RADAR DETECTION SENSOR			PREFORMED DETECTOR LOOP	 	 			
VIDEO DETECTION CAMERA			SAMPLING (SYSTEM) DETECTOR	 	 			
RADAR/VIDEO DETECTION ZONE			INTERSECTION AND SAMPLING (SYSTEM) DETECTOR	 	 			
PAN, TILT, ZOOM (PTZ) CAMERA			QUEUE AND SAMPLING (SYSTEM) DETECTOR	 	 			
EMERGENCY VEHICLE LIGHT DETECTOR			WIRELESS DETECTOR SENSOR					
CONFIRMATION BEACON			WIRELESS ACCESS POINT					
WIRELESS INTERCONNECT								
WIRELESS INTERCONNECT RADIO REPEATER								

TS SHT NO. 1

MODEL: Default
FILE: \\home\user\workspace\projects\171939\CD\Drawings\Traffic\171939-114-1.dgn

USER NAME = koby/kaka	DESIGNED - IP	REVISED -
	DRAWN - IP	REVISED -
PLOT SCALE = 100.0000' / in.	CHECKED - LP	REVISED -
PLOT DATE = 10/26/2020	DATE - 9/29/2016	REVISED -

STATE OF ILLINOIS
DEPARTMENT OF TRANSPORTATION

DISTRICT ONE			
STANDARD TRAFFIC SIGNAL DESIGN DETAILS			
SCALE: NONE	SHEET 1	OF 7 SHEETS	STA. TO STA.

F.A.P. RTE. 303	SECTION (134 & 134X) N	COUNTY LAKE	TOTAL SHEETS 129	SHEET NO. 67
TS-05			CONTRACT NO. 60V39	
ILLINOIS FED. AID PROJECT				

LOOP DETECTOR NOTES

- EACH PAIR OF LOOP WIRES SHALL BE PLACED IN A SEPARATE EMPTY COILABLE NONMETALLIC CONDUIT FROM THE EDGE OF PAVEMENT TO THE HANDHOLE. SPACING BETWEEN THE HOLES DRILLED IN THE PAVEMENT SHALL NOT BE LESS THAN 6" (150 mm). EMPTY COILABLE NONMETALLIC CONDUIT SHALL BE INCLUDED IN THE COST OF THE LOOP WIRE.
- THE NUMBER OF LOOP TURNS SHALL BE AS RECOMMENDED BY THE AMPLIFIER MANUFACTURER. ALL ADJACENT SIDES OF THE LOOPS SHALL BE INSTALLED IN SUCH A WAY THAT THE CURRENT FLOW IS IN THE SAME DIRECTION TO REINFORCE ITS MAGNETIC FIELDS FOR SMALL VEHICLE DETECTION.
- EACH LOOP LEAD-IN SHALL BE IDENTIFIED AND PERMANENTLY TAGGED IN THE HANDHOLE. EACH LEAD-IN CABLE TAG SHALL INDICATE THE LOCATION OF THE LOOP, LOOP ROTATION (CLOCKWISE/COUNTERCLOCKWISE), LOOP LEAD-IN DIRECTION (IN OR OUT), LOOP CABLE NUMBER AND LOCATION IN CABINET, AND NUMBER OF TURNS IN THE DETECTOR LOOPS IN WATER PROOF INK AS INDICATED ON THE DISTRICT 1 STANDARD TRAFFIC SIGNAL DESIGN DETAIL. THE CONTRACTOR SHALL MARK LOOP LOCATIONS ON RECORD DRAWINGS AND PRESENT TO THE ENGINEER AFTER FINAL INSPECTION. LOOPS SHALL BE MARKED BY LANE AND LOOP NUMBER. SEE DETAIL BELOW.
- ALL LOOP CABLE SHALL BE FASTENED WITH PLASTIC TIE WRAP TO THE HANDHOLE HOOKS.
- IN ASPHALT PAVEMENT, LOOPS SHOULD BE PLACED IN THE BINDER AND DIVESHOLES MARKED AT THE CURB WITH A SAW-CUT. THE SAW-CUT SHALL BE CUT IN ACCORDANCE WITH LOCAL AND E.P.A. DUST CONTROL REQUIREMENTS. DETECTOR LOOP(S) SHALL NOT BE INSTALLED IN WET CONDITIONS AND THE SAW-CUTS MUST BE FREE OF DEBRIS AND RESIDUE SUCH AS DUST AND WATER WHICH IS TO BE ACHIEVED BY THE USE OF COMPRESSED AIR, WIRE BRUSHING AND HEAT DRYING ACCORDING TO SEALANT MANUFACTURER REQUIREMENTS. THE DETECTOR WIRE SHALL BE HELD IN PLACE BY THE USE OF FORM WEDGES. WEDGES SHALL BE SPACED NO MORE THAN 18" (450 mm) APART.
- LOOP SPLICES SHALL BE SOLDERED USING A SOLDERING IRON. BLOW TORCHES OR OTHER DEVICES WHICH OXIDIZE COPPER CABLE SHALL NOT BE ALLOWED FOR SOLDERING OPERATIONS. SEE DETAIL BELOW RIGHT.
- PREFORMED DETECTOR LOOPS SHALL BE USED, AS SHOWN ON THE PLANS, WHERE NEW CONCRETE PAVEMENT IS PROPOSED. THE INSTALLATION OF PREFORMED LOOPS SHALL BE IN ACCORDANCE WITH THE DISTRICT 1 SPECIFICATIONS OR AS DIRECTED BY THE ENGINEER.

LOOP LEAD-IN CABLE TAG

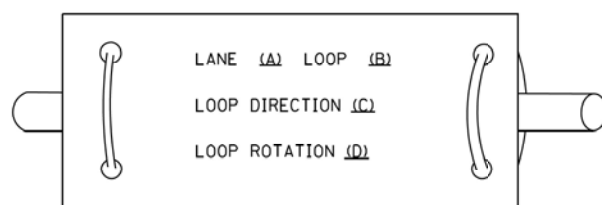

- LANE 1 IS THE LANE CLOSEST TO THE CENTERLINE OF THE ROADWAY
- LOOP #1 IS THE LOOP IN THE LANE CLOSEST TO THE INTERSECTION.
- LABEL LOOP CABLE "IN" OR LOOP CABLE "OUT".
- LABEL LOOP CABLE CLOCKWISE OR LOOP CABLE COUNTERCLOCKWISE.

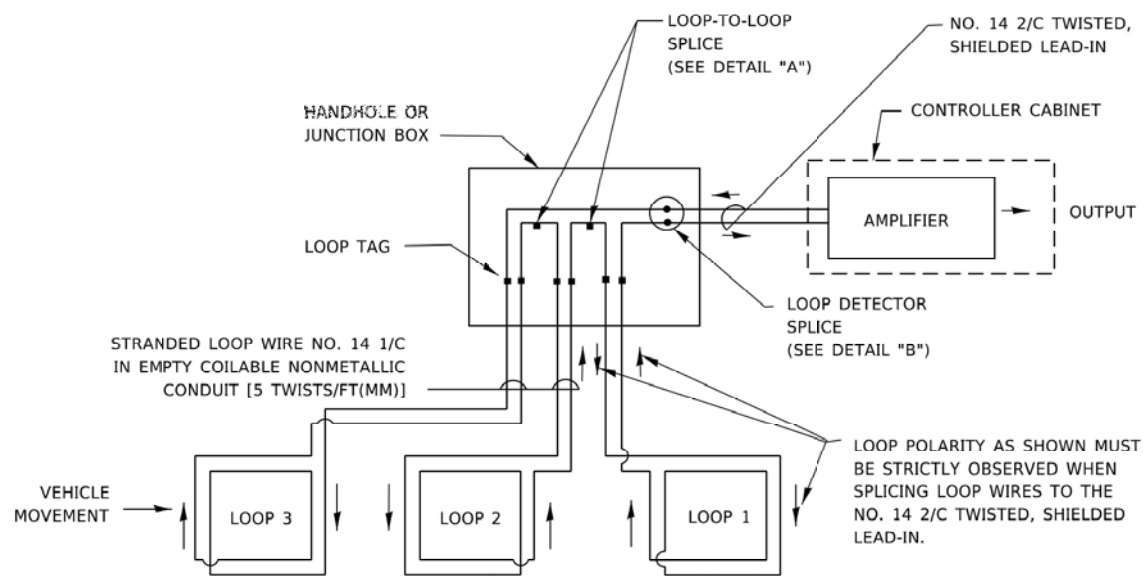

DETECTOR LOOP WIRING SCHEMATIC

- LOOPS SHALL BE SPLICED IN SERIES. SAW-CUTS SHALL BE A MINIMUM WIDTH OF 5/16" (8 mm).
- SAW-CUT DEPTHS SHALL BE 3" (75 mm). IF IN CONCRETE.
- THE SAW-CUT DEPTH SHALL BE TO THE TOP OF THE REINFORCEMENT.
- LOOP CORNERS SHALL BE DRILLED WITH A 2" (50 mm) DIAMETER CORE.

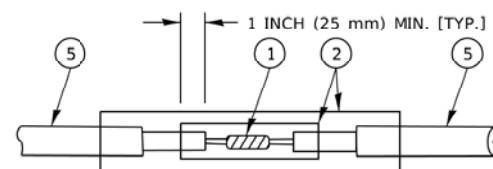

DETAIL "A"
LOOP-TO-LOOP SPLICE

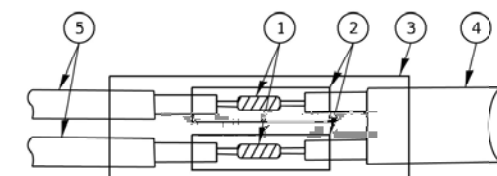

DETAIL "B"
LOOP-TO-CONTROLLER SPLICE

TYPE I LOOP

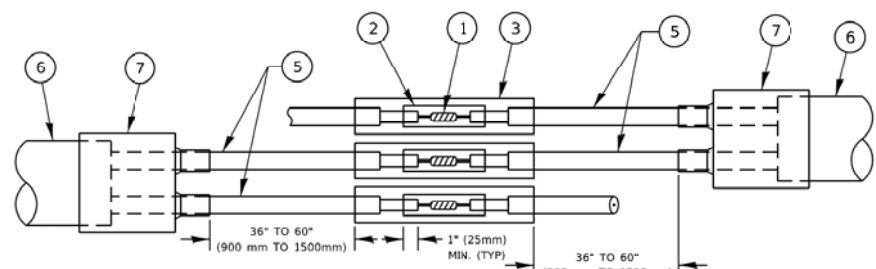

DETAIL "A"
LOOP-TO-LOOP SPLICE

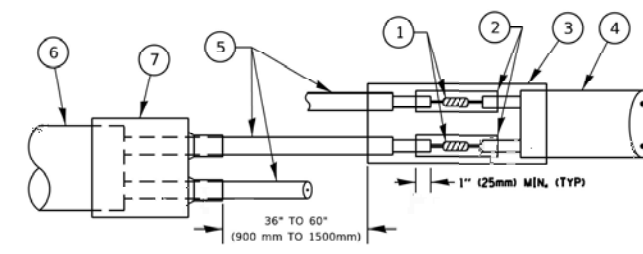

DETAIL "B"
LOOP-TO-CONTROLLER SPLICE

PREFORMED LOOP

LOOP DETECTOR SPLICE

- WESTERN UNION SPLICE SOLDERED WITH ROSIN CORE FLUX. ALL EXPOSED SURFACES OF THE SOLDER SHALL BE SMOOTH. THE WESTERN UNION SPLICES SHALL BE STAGGERED.
- WCSMW 30/100 HEAT SHRINK TUBE, MINIMUM LENGTH 3" (75 mm), UNDERWATER GRADE.
- WCS 200/750 HEAT SHRINK TUBE, MINIMUM LENGTH 6" (150 mm), UNDERWATER GRADE.
- NO. 14 2/C TWISTED, SHIELDED CABLE.
- LOOP CONDUCTOR WITH FLEXIBLE PLASTIC TUBE. PREFORMED LOOP
- XL POLYOLEFIN 2 CONDUCTOR
- BREAKOUT SEALS. TYCO CBR-2 OR APPROVED EQUAL

USER NAME = koby/kaka	DESIGNED -	REVISD -
	DRAWN -	REVISED -
PLOT SCALE = 100.0000' / in.	CHECKED -	REVISED -
PLOT DATE = 10/26/2020	DATE -	REVISED -

DISTRICT ONE		F.A.P. RTE.	SECTION	COUNTY	TOTAL SHEETS	SHEET NO.
STANDARD TRAFFIC SIGNAL DESIGN DETAILS		303	(134 & 134X) N	LAKE	129	68
SCALE: NONE		TS-05		CONTRACT NO. 60V39		
SHEET 2	OF 7 SHEETS	STA.	ILLINOIS FED. AID PROJECT			

TRAFFIC SIGNAL MAST ARM AND SIGNAL POST

MAST ARM MOUNTED SIGNALS IN EXISTING, PROPOSED OR FUTURE SIDEWALK/BICYCLE PATH AREA. INTERSECTION SHOWN WITH PEDESTRIAN SIGNALS AND PEDESTRIAN PUSHBUTTON DETECTORS.

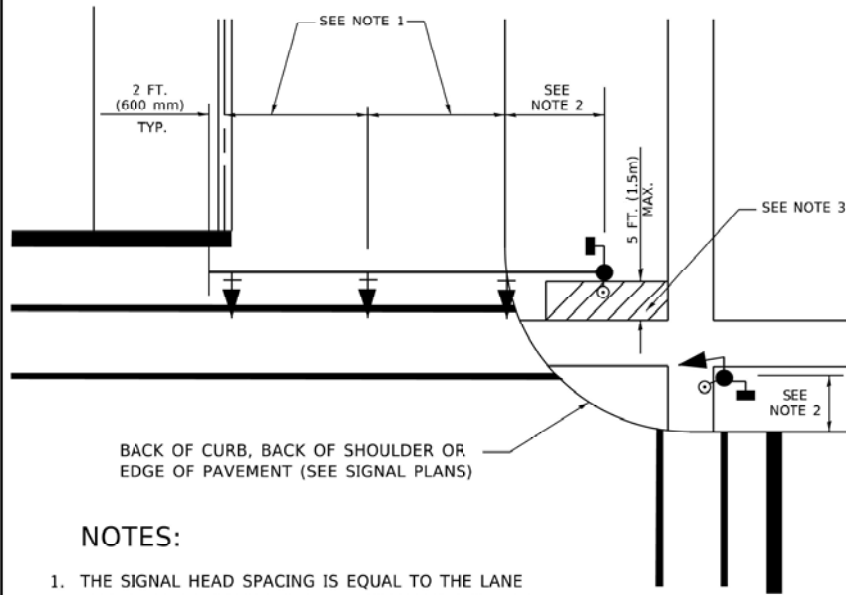

BACK OF CURB, BACK OF SHOULDER OR EDGE OF PAVEMENT (SEE SIGNAL PLANS)

NOTES:

1. THE SIGNAL HEAD SPACING IS EQUAL TO THE LANE WIDTH OR AS SHOWN ON THE TRAFFIC SIGNAL PLAN.
2. REFER TO THE TRAFFIC SIGNAL EQUIPMENT OFFSET TABLE.
3. PROVIDE A LEVEL ALL-WEATHER SURFACE (CONCRETE SIDEWALK, ASPHALT BICYCLE PATH SURFACE OR MATCHING MATERIAL TO THE ADJACENT SURFACE) UP TO THE MAST ARM SHAFT OR THE SIGNAL POST.
4. THE FACE OF THE PEDESTRIAN PUSHBUTTON SHALL BE PARALLEL TO THE CROSSWALK TO BE USED.
5. THE LOCATIONS AND INSTALLATION OF PEDESTRIAN SIGNAL HEADS AND PEDESTRIAN PUSHBUTTONS SHALL MEET THE REQUIREMENTS OF THE MUTCD AND INFORMATION FOUND IN THE "AMERICANS WITH DISABILITIES ACT ACCESSIBILITY GUIDELINES FOR BUILDINGS AND FACILITIES."

PEDESTRIAN SIGNAL POST AND PEDESTRIAN PUSH BUTTON POST

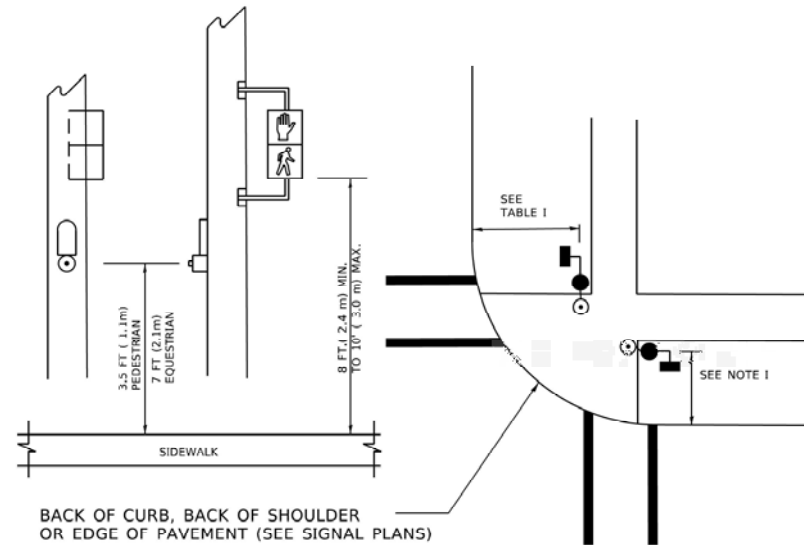

BACK OF CURB, BACK OF SHOULDER OR EDGE OF PAVEMENT (SEE SIGNAL PLANS)

NOTES:

1. REFER TO THE TRAFFIC SIGNAL EQUIPMENT OFFSET TABLE.
2. PROVIDE A LEVEL ALL-WEATHER SURFACE (CONCRETE SIDEWALK, ASPHALT BICYCLE PATH SURFACE OR MATCHING MATERIAL TO THE ADJACENT SURFACE) UP TO THE PEDESTRIAN SIGNAL POST OR THE PEDESTRIAN PUSH BUTTON POST.
3. THE FACE OF THE PEDESTRIAN PUSHBUTTON SHALL BE PARALLEL TO THE CROSSWALK TO BE USED.
4. THE LOCATIONS AND INSTALLATION OF PEDESTRIAN SIGNAL HEADS AND PEDESTRIAN PUSHBUTTONS SHALL MEET THE REQUIREMENTS OF THE MUTCD AND INFORMATION FOUND IN THE "AMERICANS WITH DISABILITIES ACT ACCESSIBILITY GUIDELINES FOR BUILDINGS AND FACILITIES."

RECOMMENDED PUSHBUTTON LOCATIONS

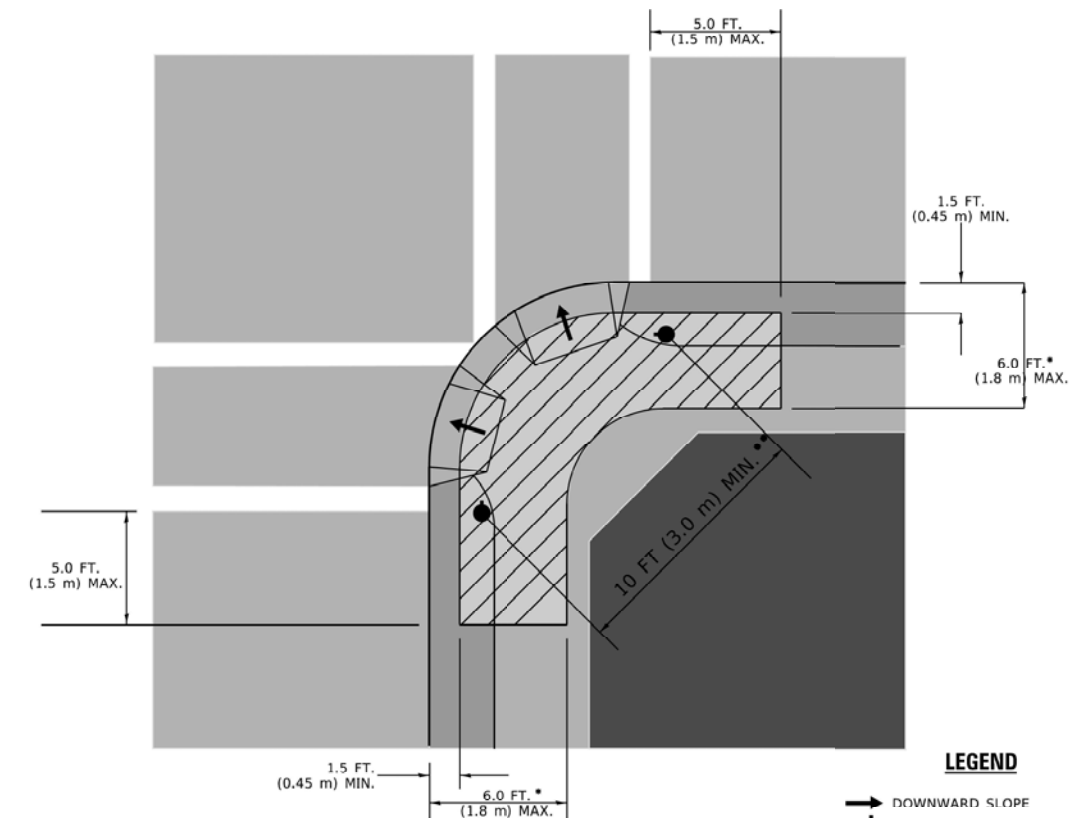

LEGEND

- DOWNWARD SLOPE
- PEDESTRIAN PUSHBUTTON
- ▨ RECOMMENDED PUSHBUTTON LOCATIONS

- * WHERE THERE ARE CONSTRAINTS THAT MAKE IT IMPRACTICAL TO PLACE THE PEDESTRIAN PUSHBUTTON BETWEEN 1.5 FT (0.45 m) AND 6 FT (1.8 m) FROM THE EDGE OF THE CURB, SHOULDER, OR PAVEMENT, IT SHOULD NOT BE FURTHER THAN 10 FT (3 m) FROM THE EDGE OF CURB, SHOULDER, OR PAVEMENT.
- ** WHERE THERE ARE CONSTRAINTS ON A PARTICULAR CORNER THAT MAKE IT IMPRACTICAL TO PROVIDE THE 10 FT (3 m) SEPERATION BETWEEN THE TWO PEDESTRIAN PUSHBUTTONS, THE PUSHBUTTONS MAY BE PLACED CLOSER TOGETHER OR ON THE SAME POLE.

NOTES:

1. PEDESTRIAN SIGNAL HEADS SHALL BE MOUNTED WITH THE BOTTOM OF THE SIGNAL HOUSING INCLUDING BRACKETS NOT LESS THAN 8 FT (2.4 m) OR MORE THAN 10 FT (3 m) ABOVE SIDEWALK LEVEL, AND SHALL BE POSITIONED AND ADJUSTED TO PROVIDE MAXIMUM VISIBILITY AT THE BEGINNING OF THE CONTROLLED CROSSWALK.
2. THE BOTTOM OF THE SIGNAL HOUSING (INCLUDING BRACKETS) OF A VEHICULAR SIGNAL FACE THAT IS NOT LOCATED OVER A HIGHWAY SHALL BE AT LEAST 8 FT (2.4 m) BUT NOT MORE THAN 19 FT (5.8 m) ABOVE THE SIDEWALK OR, IF THERE IS NO SIDEWALK, ABOVE THE PAVEMENT GRADE AT THE CENTER OF THE ROADWAY.
3. THE BOTTOM OF THE SIGNAL HOUSING AND ANY RELATED ATTACHMENTS TO A SIGNAL FACE LOCATED OVER ANY PORTION OF A HIGHWAY SHALL BE ACCORDING TO CURRENT STATE STANDARDS 877001, 877002, 877006, 877011 AND 877012 WITH A MINIMUM OF 16 FT (5.0 m) AND A MAXIMUM OF 18 FT. (5.5 m) FROM THE HIGHEST POINT OF PAVEMENT.
4. THE BOTTOM OF THE TEMPORARY SPAN WIRE MOUNTED SIGNAL HOUSING AND ANY RELATED ATTACHMENTS TO A SIGNAL FACE LOCATED OVER ANY PORTION OF A HIGHWAY SHALL BE ACCORDING TO CURRENT STATE STANDARD 880001 WITH A MINIMUM OF 17 FT (5.18 m) FROM THE HIGHEST POINT OF PAVEMENT.
5. THE TOP OF THE SIGNAL HOUSING OF A SIGNAL FACE LOCATED OVER ANY PORTION OF A HIGHWAY SHALL NOT BE MORE THAN 25.6 FT (7.8 m) ABOVE THE PAVEMENT.

TRAFFIC SIGNAL EQUIPMENT OFFSET

TRAFFIC SIGNAL EQUIPMENT	COMBINATION CONCRETE CURB AND GUTTER (MINIMUM DISTANCE FROM BACK OF CURB TO CENTERLINE OF FOUNDATION)	SHOULDER/NON-CURBED AREA (MINIMUM DISTANCE FROM EDGE OF PAVEMENT TO CENTERLINE OF FOUNDATION)
TRAFFIC SIGNAL MAST ARM POLE	6 FT (1.8m)	SHOULDER WIDTH + 2 FT (0.5m), MINIMUM 10 FT (3.0m)
TRAFFIC SIGNAL POST	4 FT (1.2m)	SHOULDER WIDTH + 2 FT (0.5m), MINIMUM 10 FT (3.0m)
PEDESTRIAN SIGNAL POST	4 FT (1.2m)	SHOULDER WIDTH + 2 FT (0.5m), MINIMUM 10 FT (3.0m)
PEDESTRIAN PUSHBUTTON POST	4 FT (1.2m)	SHOULDER WIDTH + 2 FT (0.5m), MINIMUM 10 FT (3.0m)
TEMPORARY WOOD POLE	6 FT (1.8m)	SHOULDER WIDTH + 2 FT (0.5m), MINIMUM 10 FT (3.0m)
CONTROLLER CABINET	6 FT (1.8m) MINIMUM DISTANCE SEE NOTE 2	SHOULDER WIDTH + 6 FT (1.3m), MINIMUM 16 FT (4.9m) SEE NOTE 3.
SERVICE INSTALLATION, GROUND MOUNT	6 FT (1.8m) MINIMUM DISTANCE SEE NOTE 2	SHOULDER WIDTH + 6 FT (1.3m), MINIMUM 16 FT (4.9m) SEE NOTE 3.

NOTES:

1. CONTACT THE "AREA TRAFFIC SIGNAL MAINTENANCE AND OPERATIONS ENGINEER" FOR ASSISTANCE IN LOCATING THE TRAFFIC SIGNAL EQUIPMENT WHEN THERE ARE CONFLICTS WITH DITCHES OR THE MINIMUM OFFSET DISTANCES CANNOT BE MET.
2. MINIMUM DISTANCE FROM THE BACK OF CURB TO THE ROADWAY SIDE OF THE FOUNDATION.
3. MINIMUM DISTANCE FROM THE EDGE OF PAVEMENT TO THE ROADWAY SIDE OF THE FOUNDATION.
4. ANY CHANGES TO THE OFFSETS OF THE FOUNDATIONS, FROM THE MINIMUM DISTANCES LISTED IN THE "TRAFFIC SIGNAL EQUIPMENT OFFSET" CHART AND THE TRAFFIC SIGNAL INSTALLATION PLAN, COULD EFFECT THE PLACEMENT OF THE SIGNAL HEADS, PEDESTRIAN SIGNAL HEADS AND THE PEDESTRIAN PUSHBUTTONS. THE SIGNAL HEAD PLACEMENT ON THE MAST ARMS SHALL REMAIN AS PER THE TRAFFIC SIGNAL INSTALLATION PLAN AND THE "TRAFFIC SIGNAL MAST ARM AND SIGNAL POST" DETAIL ABOVE. THE PROPOSED MAST ARM LENGTHS MAY NEED TO BE REVISED TO MEET THE ABOVE REQUIREMENTS. THE PEDESTRIAN SIGNAL HEADS AND PEDESTRIAN PUSHBUTTONS MUST MEET THE REQUIREMENTS UNDER THE DETAILS ON THIS SHEET.

TS SHT NO. 3

MODEL: D:\a\itc... FILE NAME: p... OFFICE: ...

USER NAME = koby/kaka	DESIGNED -	REVISED -
PLOT SCALE = 100.0000' / in.	DRAWN -	REVISED -
PLOT DATE = 10/26/2020	CHECKED -	REVISED -
	DATE -	REVISED -

**STATE OF ILLINOIS
DEPARTMENT OF TRANSPORTATION**

**DISTRICT ONE
STANDARD TRAFFIC SIGNAL DESIGN DETAILS**

SCALE: NONE SHEET 3 OF 7 SHEETS STA. TO STA.

F.A.P. RTE.	SECTION	COUNTY	TOTAL SHEETS	SHEET NO.
303	(134 & 134X) N	LAKE	129	69
TS-05		CONTRACT NO. 60V39		
ILLINOIS FED. AID PROJECT				

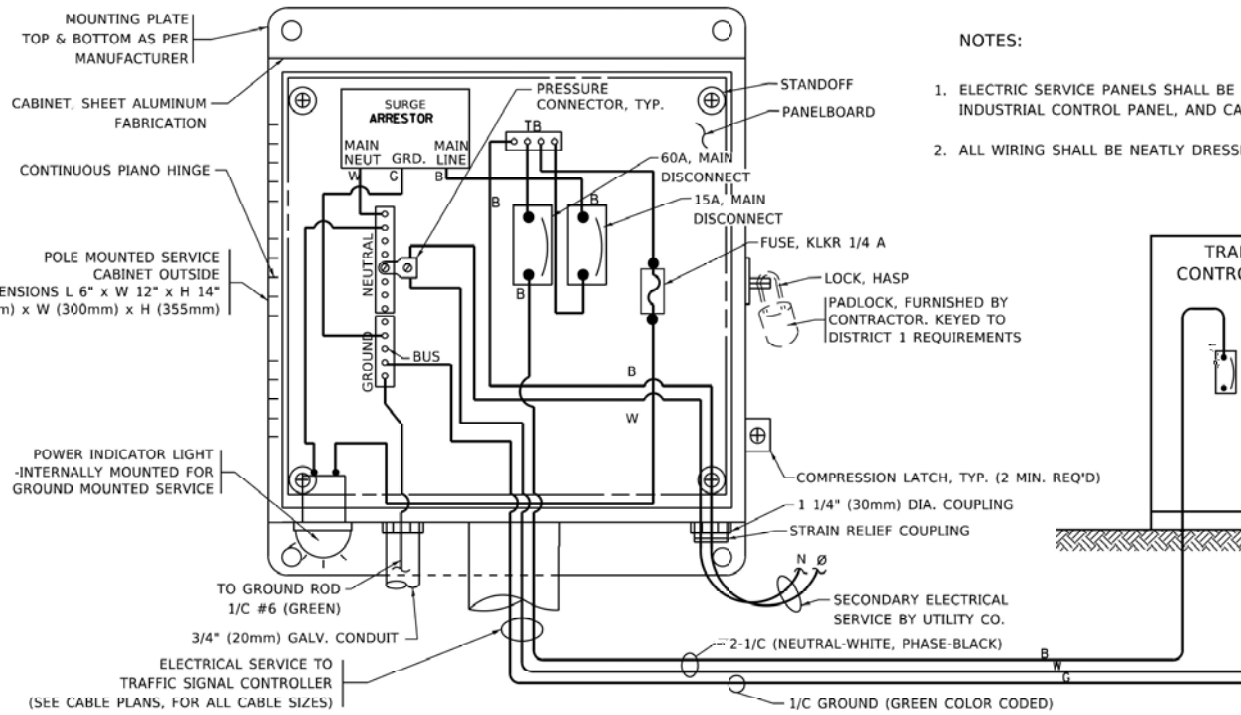

ELECTRICAL SERVICE – PANEL DIAGRAM (TYPICAL FOR POLE AND GROUND MOUNTED SERVICE)
SERVICE INSTALLATION POLE MOUNT (SHOWN)
 (NOT TO SCALE)

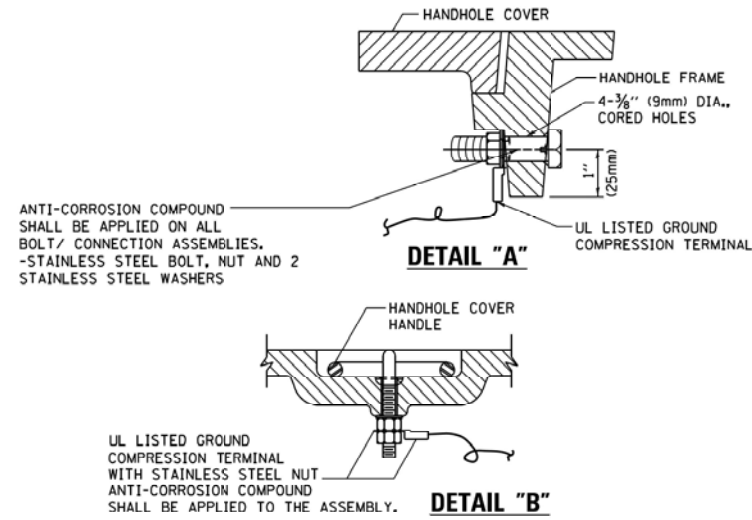
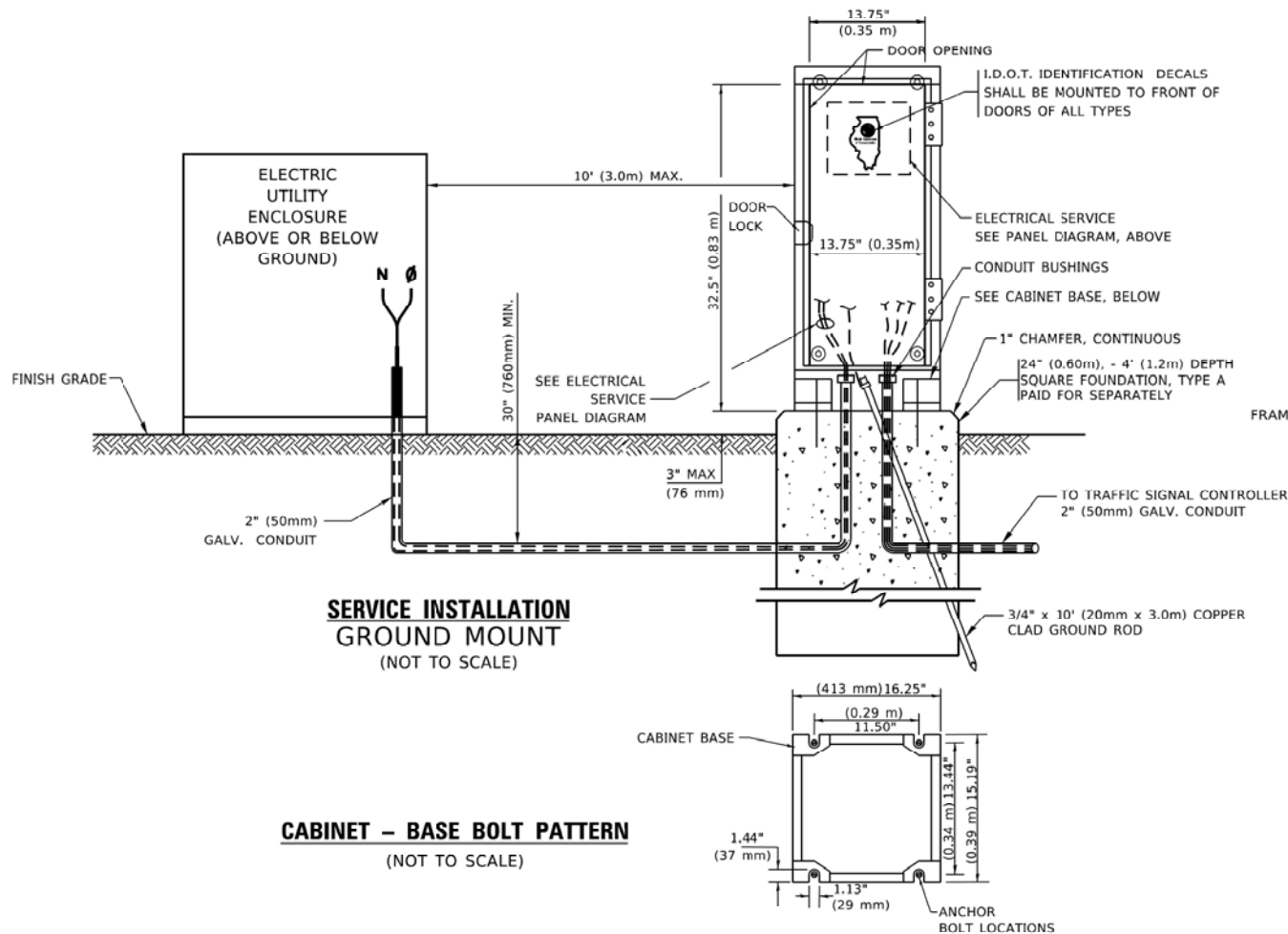

NOTES:
GROUNDING SYSTEM

- THE GROUNDING SYSTEM SHALL CONSIST OF AN INSULATED CONDUCTOR TYPE XLP, NO. 6 A.W.G., STRANDED COPPER TO BE INSTALLED IN RACEWAYS. THE GROUNDING CABLE SHALL BE INSTALLED IN A CONTINUOUS MANNER AS SHOWN ON THE CABLE PLAN PROVIDED. ALL GROUNDING CONDUCTORS SHALL BE BONDED TO METAL ENCLOSURE (HANDHOLE, POST, MAST ARM, CONTROLLER, ETC.). GROUND ROD SHALL BE 3/4" DIA. x 10'-0" (20mm x 3.0m) LONG, COPPER CLAD. ONE GROUND ROD SHALL BE INSTALLED AT ALL POST FOUNDATIONS, POLE FOUNDATIONS, CONTROLLER CABINET FOUNDATION AND ELECTRICAL SERVICE INSTALLATION, AS INDICATED ON THE CABLE PLAN. IF THERE ARE ANY SPECIAL CONDITIONS SUCH AS SUB-SURFACE CONDITIONS OR INSTALLATION PROBLEMS, THE RESIDENT ENGINEER SHALL BE NOTIFIED OR CONTACT THE BUREAU OF TRAFFIC, ILLINOIS DEPARTMENT OF TRANSPORTATION DISTRICT ONE AT (847) 705-4139.
- THE NEUTRAL CONDUCTOR AND THE GROUND CONDUCTOR SHALL BE CONNECTED IN THE SERVICE INSTALLATION. AT NO OTHER POINT IN THE TRAFFIC SIGNAL SYSTEM SHALL THE NEUTRAL AND GROUND CONDUCTORS BE CONNECTED.
- ALL EQUIPMENT GROUNDING CONDUCTORS SHALL TERMINATE AT THE GROUND BUS IN THE CONTROLLER CABINET.
- THE CONTRACTOR SHALL PROVIDE A GROUND CABLE WITH CONNECTORS BETWEEN THE HANDHOLE COVER AND HANDHOLE FRAME.

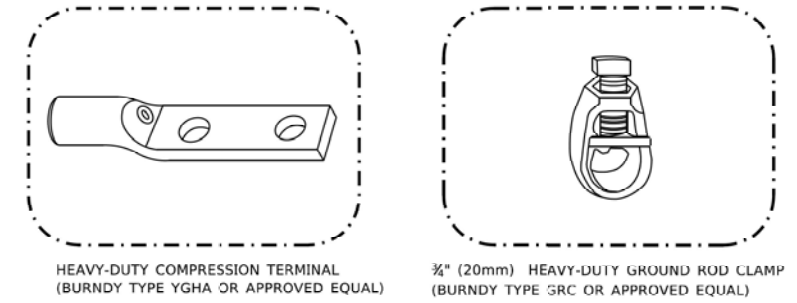
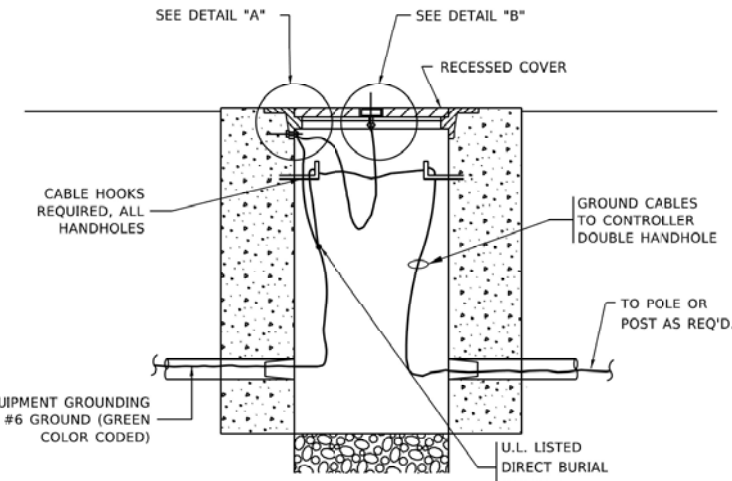

NOTES:

- ALL CLAMPS SHALL BE BRONZE OR COPPER, UL APPROVED.
- GROUND CABLE SHALL BE LOOPED OVER HOOKS IN THE HANDHOLES
- 6.5' (2.0m) SLACK SHALL BE PROVIDED IN SINGLE HANDHOLES
- 13' (4.0m) OF SLACK SHALL BE PROVIDED IN DOUBLE HANDHOLES.
- 5' (1.4m) OF SLACK SHALL BE PROVIDED BETWEEN FRAME AND COVER.

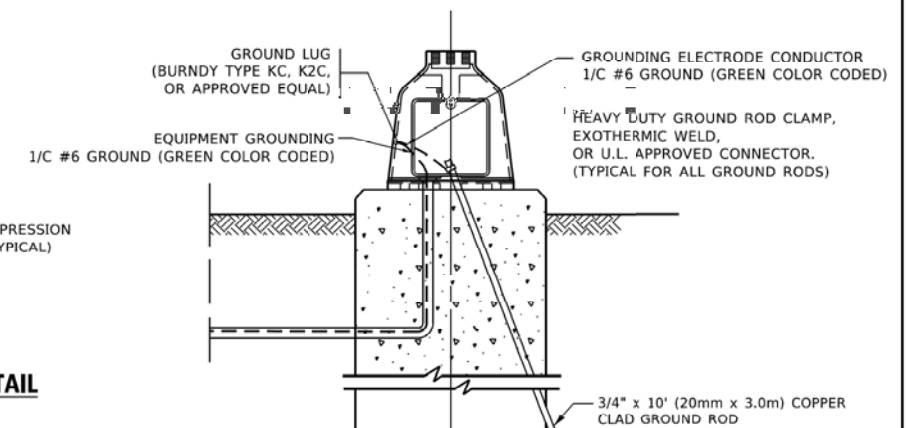
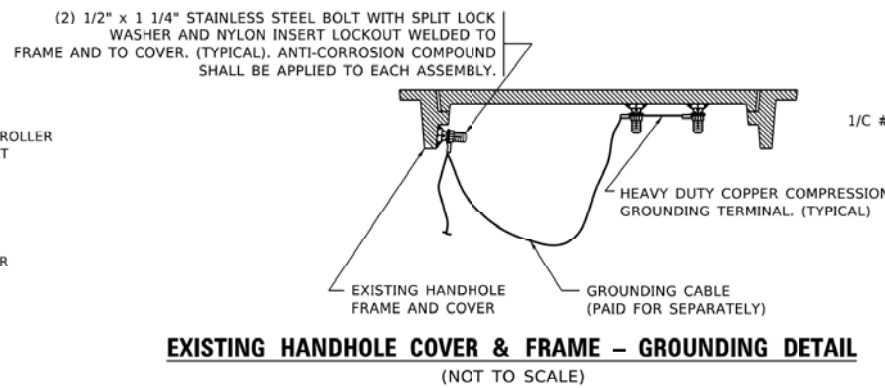

TS SHT NO. 4

MODEL: D:\dwg\...
 FILE NAME: ...

USER NAME = koby/kaka	DESIGNED -	REVISED -
PLOT SCALE = 100,0000' / in.	DRAWN -	REVISED -
PLOT DATE = 10/26/2020	CHECKED -	REVISED -
	DATE -	REVISED -

STATE OF ILLINOIS
DEPARTMENT OF TRANSPORTATION

DISTRICT ONE
STANDARD TRAFFIC SIGNAL DESIGN DETAILS

SCALE: NONE SHEET 4 OF 7 SHEETS STA. TO STA.

F.A.P. RTE.	SECTION	COUNTY	TOTAL SHEETS	SHEET NO.
303	(134 & 134X) N	LAKE	129	70
TS-05		CONTRACT NO. 60V39		
ILLINOIS FED. AID PROJECT				

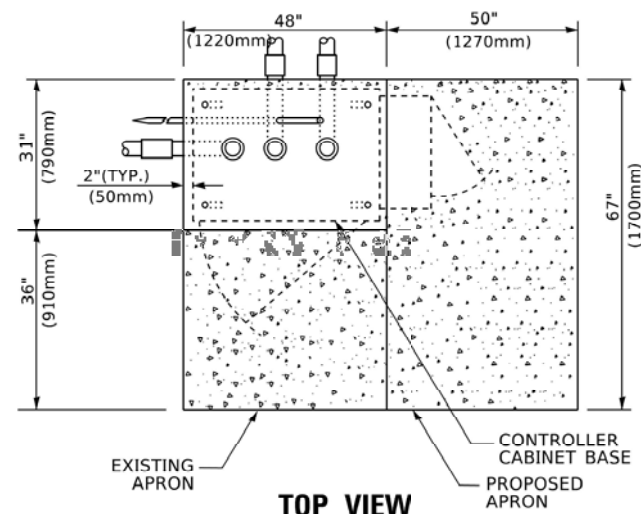

TOP VIEW

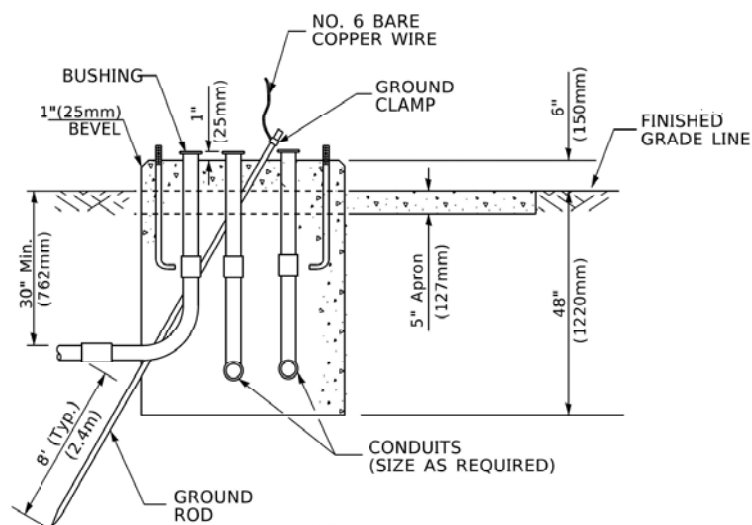

**TYPE D
FOR GROUND MOUNTED
CONTROLLER CABINET
AND UPS BATTERY CABINET**

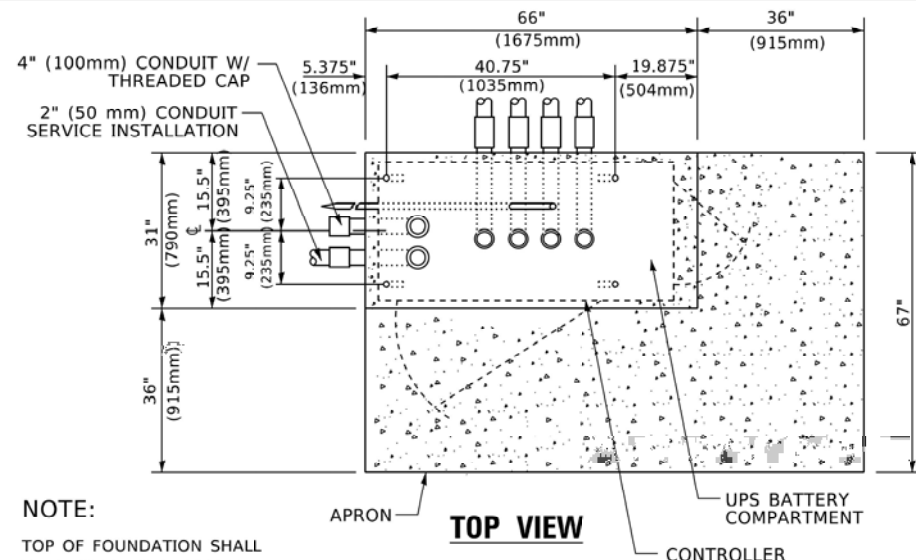

TOP VIEW

NOTE:
TOP OF FOUNDATION SHALL BE HIGHER THAN TOP OF DOUBLE HANDHOLE

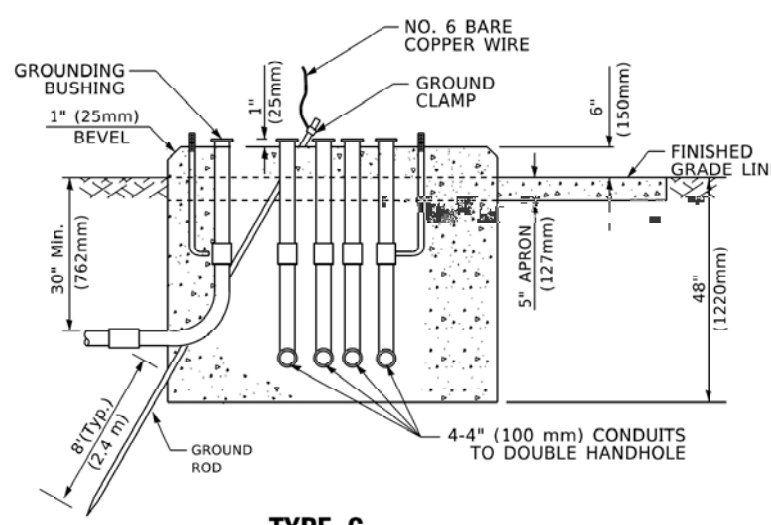

**TYPE C
FOR GROUND MOUNTED
SUPER P (TYPE IV) AND SUPER R (TYPE V)
CONTROLLER CABINETS**

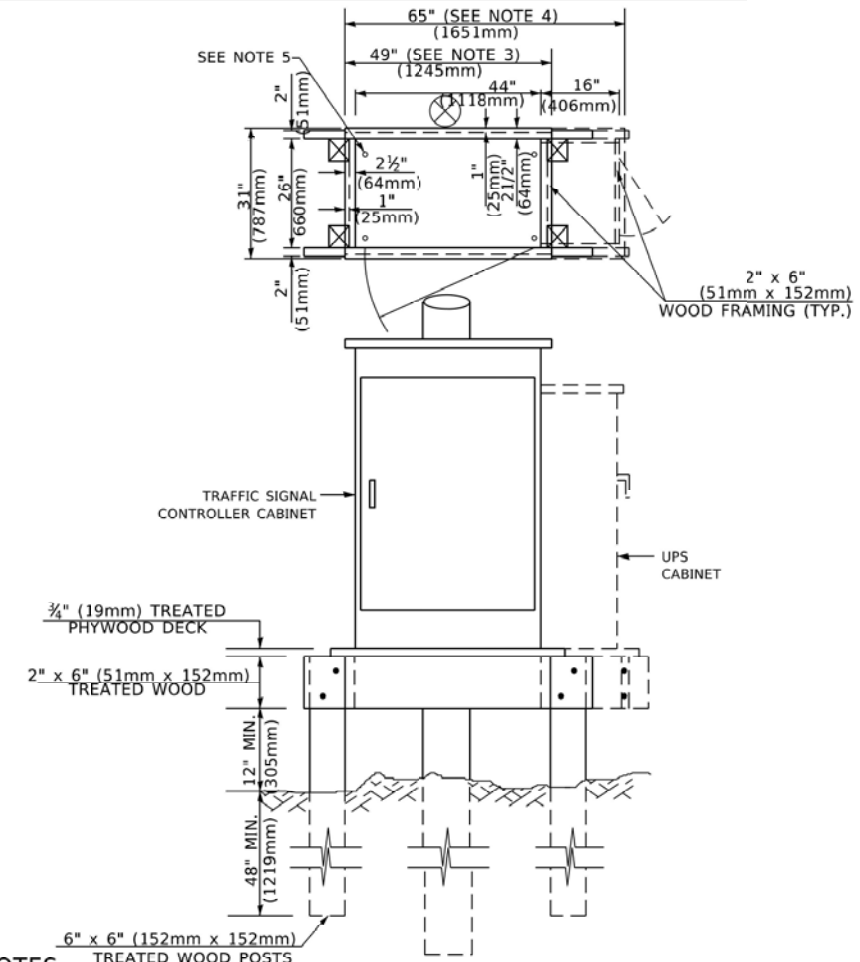

NOTES:

1. BASED ON CONTROLLER CABINET TYPE IV WITH BASE DIMENSIONS OF 26" x 44" (660mm x 1118mm). ADJUST PLATFORM SIZE TO FIT CABINET BASE DIMENSIONS BEING SUPPLIED.
2. BASED ON UNINTERRUPTIBLE POWER SUPPLY CABINET WITH BASE DIMENSIONS OF 16" x 25" (406mm x 633mm). ADJUST PLATFORM SIZE TO FIT CABINET BASE DIMENSIONS BEING SUPPLIED.
3. PLATFORM SIZE FOR CONTROLLER CABINET TYPE IV.
4. PLATFORM SIZE FOR CONTROLLER CABINET TYPE IV AND UNINTERRUPTIBLE POWER SUPPLY CABINET.
5. DRILLED HOLES THROUGH THE PLATFORM BASE TO MATCH THE CONTROLLER CABINET BOLT TEMPLATE. FASTEN THE CONTROLLER CABINET TO THE PLATFORM WITH CARRIAGE BOLTS, WASHERS AND NUTS.
6. FASTEN ALL SUPPORT WOOD FRAMING TO THE WOOD POSTS WITH 2 LAG SCREWS FOR EACH CONNECTION.

**TEMPORARY SIGNAL CONTROLLER
WOOD SUPPORT PLATFORM**

CABLE SLACK LENGTH	FEET	METER
HANDHOLE	6.5	2.0
DOUBLE HANDHOLE	13.0	4.0
SIGNAL POST	2.0	0.6
MAST ARM	2.0	0.6
CONTROLLER CABINET	1.5	0.5
FIBER OPTIC AT CABINET	13.0	4.0
ELECTRIC SERVICE AT (CABINET OR SERVICE LOCATION)	1.5	0.5
GROUND CABLE (SIGNAL POST, MAST ARM, CABINET)	1.5	0.5
GROUND CABLE (BETWEEN FRAME AND COVER)	5.0	1.6

CABLE SLACK

VERTICAL CABLE LENGTH	FEET	METER
MAST ARM POLE (MAST ARM MOUNTED SIGNAL HEAD) (L = MAST ARM LENGTH - DISTANCE TO SIGNAL HEAD FROM END OF ARM)	20.0+L	6.0+L
BRACKET MOUNTED (MAST ARM POLE OR SIGNAL POLE)	13.0	4.0
PEDESTRIAN PUSH BUTTON	6.0	2.0
SERVICE INSTALLATION POLE MOUNT TO SERVICE DROP	13.5	4.1
SERVICE INSTALLATION POLE MOUNT TO GROUND	13.5	4.1
SERVICE INSTALLATION GROUND MOUNT	6.0	2.0
FOUNDATION (SIGNAL POST, MAST ARM POLE, CONTROLLER CABINET, SERVICE-GROUND MOUNT)	3.0	1.0

VERTICAL CABLE LENGTH

FOUNDATION	DEPTH
TYPE A - Signal Post	4'-0" (1.2m)
TYPE C - CONTROLLER W/ UPS	4'-0" (1.2m)
TYPE D - CONTROLLER	4'-0" (1.2m)
SERVICE INSTALLATION, GROUND MOUNT, TYPE A - SQUARE	4'-0" (1.2m)

DEPTH OF FOUNDATION

MAST ARM LENGTH	① FOUNDATION DEPTH	FOUNDATION DIAMETER	SPIRAL DIAMETER	QUANTITY OF REBARS	SIZE OF REBARS
Less than 30' (9.1 m)	10'-0" (3.0 m)	30" (750mm)	24" (600mm)	8	6(19)
Greater than or equal to 30' (9.1 m) and less than 40' (12.2 m)	13'-6" (4.1 m)	30" (750mm)	24" (600mm)	8	6(19)
Greater than or equal to 40' (12.2 m) and less than 50' (15.2 m)	11'-0" (3.4 m)	36" (900mm)	30" (750mm)	12	7(22)
Greater than or equal to 50' (15.2 m) and up to 55' (16.8 m)	13'-0" (4.0 m)	36" (900mm)	30" (750mm)	12	7(22)
Greater than or equal to 55' (16.8 m) and less than 65' (19.8 m)	15'-0" (4.6 m)	36" (900mm)	30" (750mm)	12	7(22)
Greater than or equal to 65' (19.8 m) and up to 75' (22.9 m)	21'-0" (6.4 m)	42" (1060mm)	36" (900mm)	16	8(25)
Greater than or equal to 75' (22.9 m)	25'-0" (7.6 m)	42" (1060mm)	36" (900mm)	16	8(25)

NOTES:

1. These foundation depths are for sites which have cohesive soils (clayey silt, sandy clay, etc.) along the length of the shaft, with an average unconfined compressive strength (Q_u) > 1.0 tsf (100 kpa). This strength shall be verified by boring data prior to construction or with testing by the Engineer during foundation drilling. The Bureau of Bridges & Structures should be contacted for a revised design if other conditions are encountered.
2. Combination mast arm assemblies under 55 feet (16.8 m) shall use 36" (900 mm) diameter foundations.
3. Combination mast arm assemblies under 56 feet (16.8 m) through 75 feet (22.9 m) shall use 42" (1060 mm) diameter foundations.
4. For mast arm assemblies with dual arms refer to state standard 878001..

DEPTH OF MAST ARM FOUNDATIONS, TYPE E

USER NAME = koby/kaka	DESIGNED -	REVISED -
	DRAWN -	REVISED -
PLOT SCALE = 100.0000' / in.	CHECKED -	REVISED -
PLOT DATE = 10/26/2020	DATE -	REVISED -

F.A.P. RTE.	SECTION	COUNTY	TOTAL SHEETS	SHEET NO.
303	(134 & 134X) N	LAKE	129	71
TS-05		CONTRACT NO. 60V39		
ILLINOIS FED. AID PROJECT				

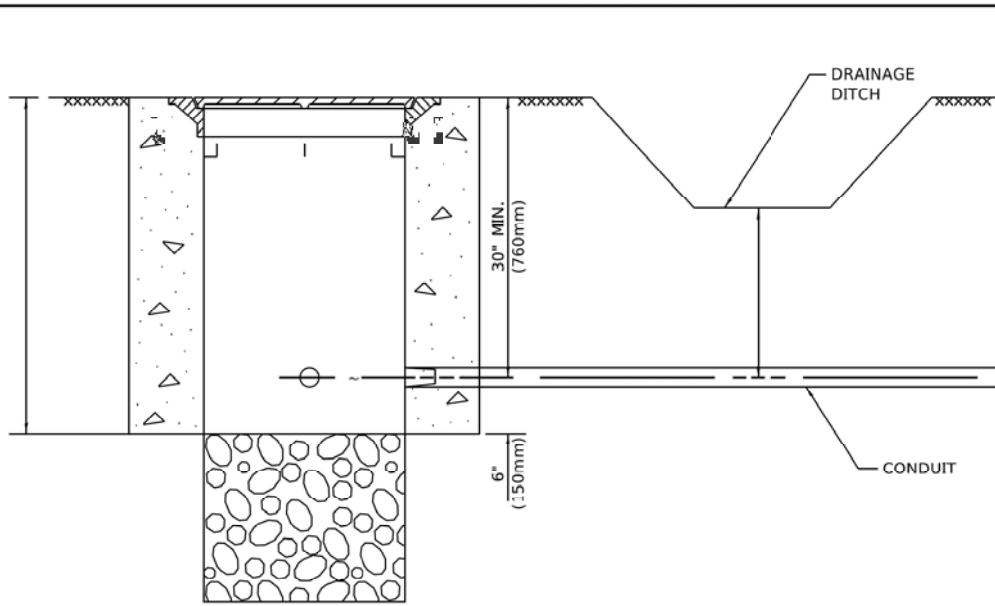

NOTES:

1. CONDUIT DEPTH SHALL BE A MINIMUM OF 30" (760mm) BELOW THE BOTTOM OF THE DRAINAGE DITCH OR ANY SLOPING GROUND
2. THE MINIMUM CONDUIT DEPTH APPLIES TO ALL CONDUIT PLACED UNDER ROADWAY PAVEMENT, MULTI-USE PATHS, SIDEWALKS AND SOIL SURFACES.
3. THE MINIMUM CONDUIT DEPTH APPLIES TO ALL HANDHOLES, HEAVY DUTY HANDHOLES AND DOUBLE HANDHOLES.

HANDHOLE WITH MINIMUM CONDUIT DEPTH
(NOT TO SCALE)

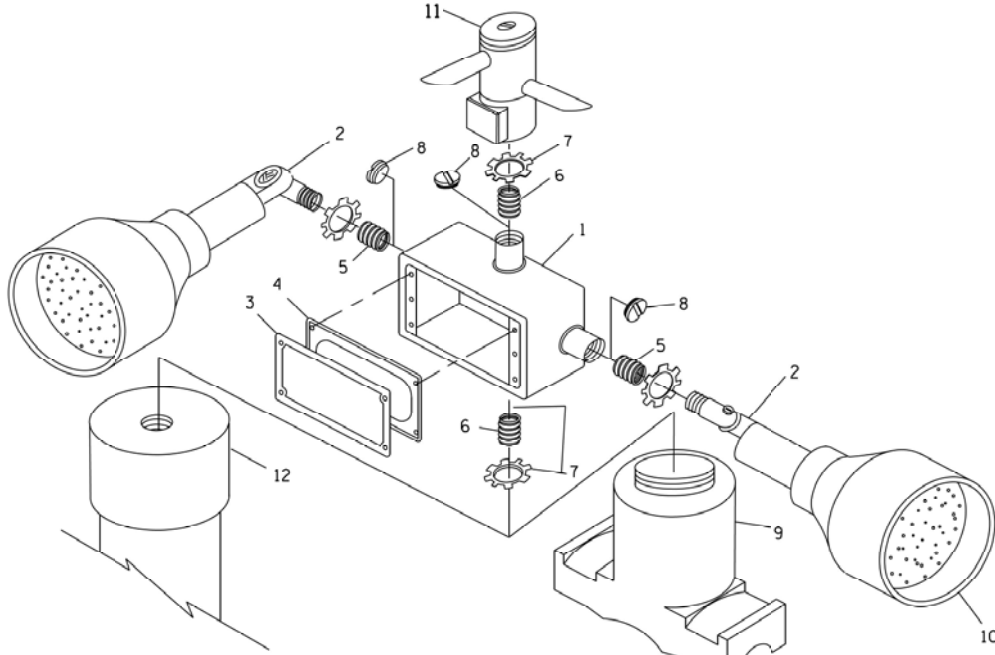

POST CAP MOUNT **MAST ARM MOUNT**
EMERGENCY VEHICLE DETECTOR WITH CONFIRMATION BEACON MOUNTING DETAIL

ITEM NO.	IDENTIFICATION
1	OUTLET BOX- GALV. 21 CU.IN. (0.000344 CU-M)
2	LAMP HOLDER AND COVER
3	OUTLET BOX COVER
4	RUBBER COVER GASKET
5	REDUCING BUSHING
6	3/4" (19 mm) CLOSE NIPPLE
7	3/4" (19 mm) LOCKNUT
8	3/4" (19 mm) HOLE PLUG
9	SADDLE BRACKET - GALV.
10	6 WATT PAR 38 LED FLOOD LAMP
11	DETECTOR UNIT
12	POST CAP [18 FT. (5.4 m) POST MIN.]

NOTES:

1. ALL ELECTRICAL ITEMS, EXCEPT ITEMS #2 AND #11 SHALL BE ALUMINUM OR GALVANIZED
2. ITEM #1- OZ/GEDNEY FSX-1-50 OR EQUIVALENT
ITEM #2- MULBERRY CON-O-SHADE LAMP SHIELD OR EQUIVALENT
ITEM #9- "BAND-IT" SADDLE BRACKET OR EQUIVALENT
3. WHEN POST MOUNTING IS SPECIFIED, ITEM #9 SHALL NOT BE REQUIRED. THE DETECTION UNIT SHALL BE MOUNTED DIRECTLY ON TOP OF THE CAP BY DRILLING AND TAPPING A 3/4" (19 mm) HOLE WITH PIPE THREADS. THE POST CAP SHALL EITHER BE SCREWED TO THE TOP OF THE POST OR A MINIMUM OF 3 TIGHTENING SCREWS SHALL BE REQUIRED ON EACH CAP.

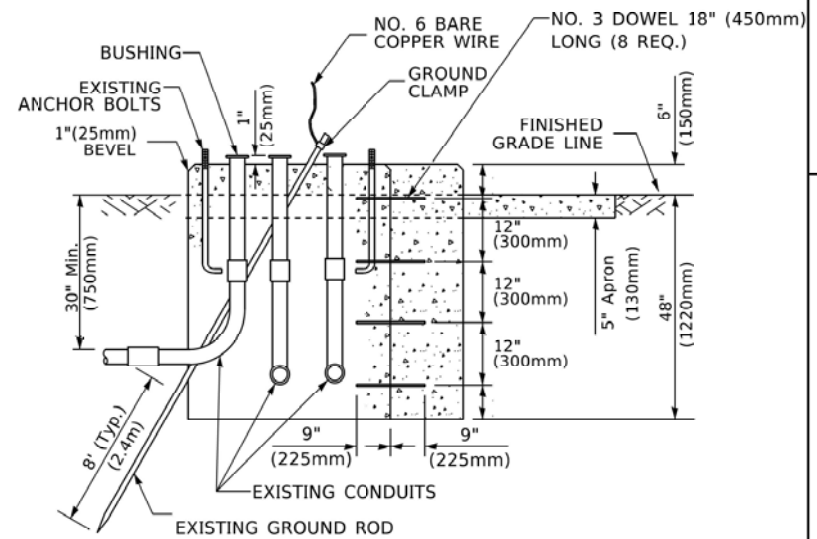
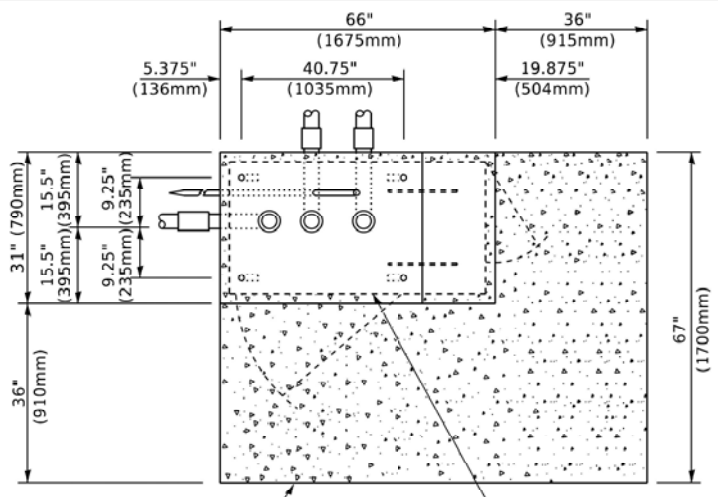

MODIFY EXISTING TYPE "D" FOUNDATION TO TYPE "C" FOUNDATION
(NOT TO SCALE)

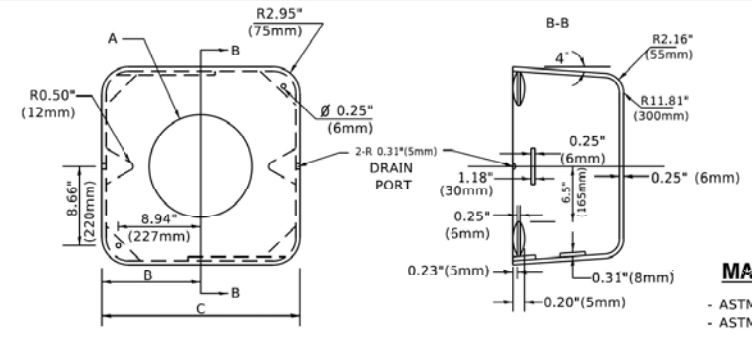

A	B	C	HEIGHT	WEIGHT
VARIES	9.5"(241mm)	19"(483mm)	7" (178mm) - 12" (300mm)	53 lbs (24kg)
VARIES	10.75"(273mm)	21.5"(546mm)	7" (178mm) - 12" (300mm)	68 lbs (31 kg)
VARIES	13.0"(330mm)	26"(660mm)	7" (178mm) - 12" (300mm)	81 lbs (37 kg)
VARIES	18.5"(470mm)	37"(940mm)	7" (178mm) - 12" (300mm)	126 lbs (57 kg)

SHROUD

NOTES:

1. DIMENSION "A" IS EQUAL TO THE DIAMETER OF THE MAST ARM POLE AT THE TOP OF THE SHROUD. THE SHROUD SHALL BE TIGHT TO THE MAST ARM POLE.
2. THE SUPPLIER SHALL VERIFIED THE ABOVE DIMENSIONS BASED ON MAST ARM REQUIREMENTS.
3. THE HEIGHT OF THE SHROUD SHALL COVER THE ANCHOR BOLTS, NUTS AND MAST ARM POLE BASE.

NOTE:

SUPPORT EXISTING CABINET AND CONTROL EQUIPMENT ABOVE FOUNDATION TO KEEP TRAFFIC SIGNAL FUNCTIONING WHILE FOUNDATION MODIFICATION WORK IS PROCEEDING.

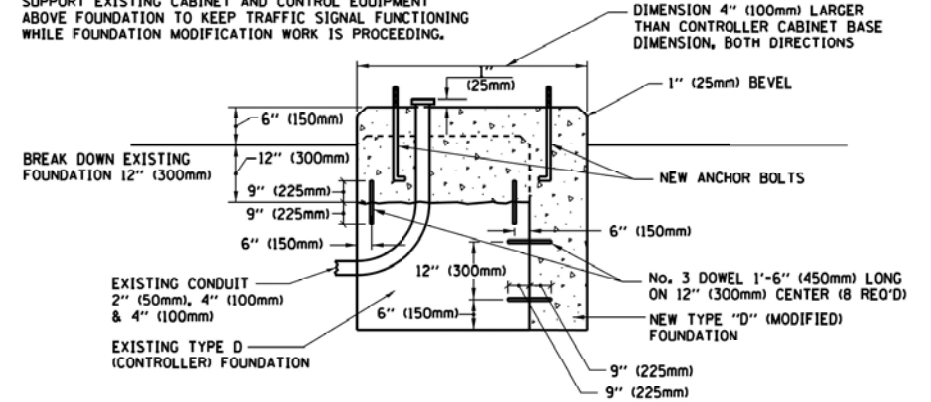

MODIFY EXISTING TYPE "D" FOUNDATION

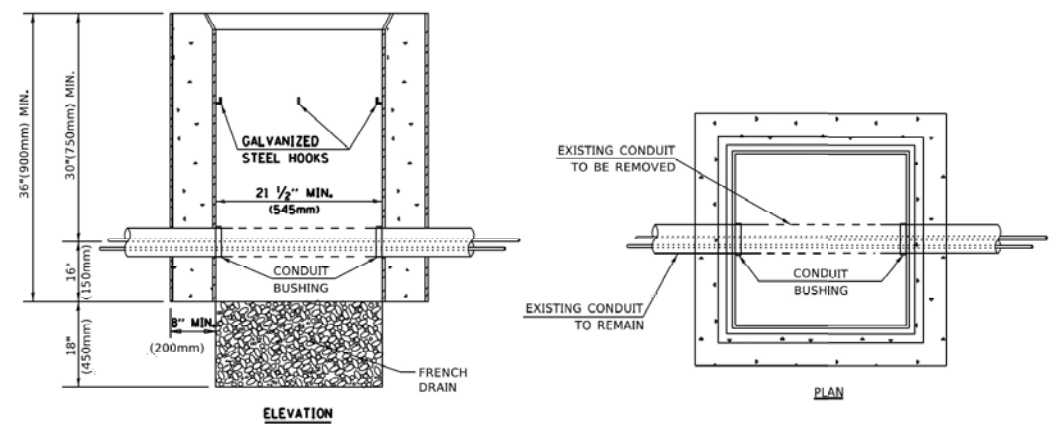

NOTES:

1. HANDHOLE CONSTRUCTED PER STATE STANDARD 814001.
2. REMOVAL OF THE EXISTING CONDUIT FROM THE HANDHOLE AND THE INSTALLATION OF THE CONDUIT BUSHINGS SHALL BE INCLUDED WITH THE COST OF THE HANDHOLE.

HANDHOLE TO INTERCEPT EXISTING CONDUIT

TS SHT NO. 6

MODEL: Dtda01t
FILE NAME: g:\proj\share\com\dot\illinois\pwr\pwr\DOT\Documents\DOT_Offices\Dotfile_1\Projects\171909\CAD\Drawn\Traffic\171909-sht-ts.dgn

USER NAME = koby/kaka	DESIGNED -	REVISED -
PLOT SCALE = 100.0000 ' / in.	DRAWN -	REVISED -
PLOT DATE = 10/26/2020	CHECKED -	REVISED -
	DATE -	REVISED -

STATE OF ILLINOIS
DEPARTMENT OF TRANSPORTATION

DISTRICT ONE
STANDARD TRAFFIC SIGNAL DESIGN DETAILS

SCALE: NONE SHEET 6 OF 7 SHEETS STA. TO STA.

F.A.P. RTE. 303	SECTION (134 & 134X) N	COUNTY LAKE	TOTAL SHEETS 129	SHEET NO. 72
TS-05		CONTRACT NO. 60V39		
ILLINOIS FED. AID PROJECT				

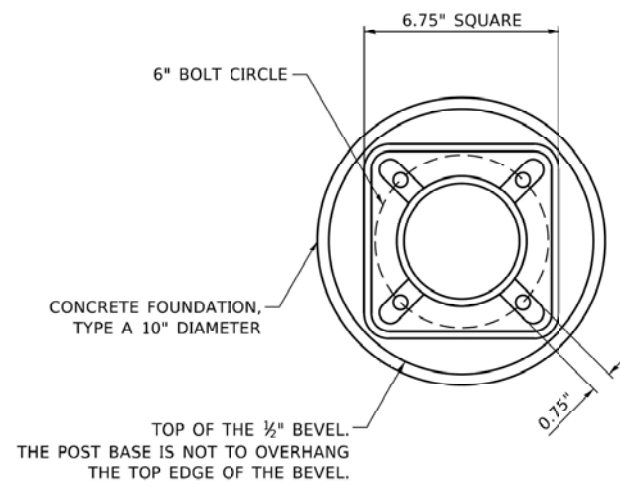

BOLT PATTERN

NOTE:
1. IF THE PEDESTRIAN SIGNAL POST FOUNDATION IS INSTALLED WITHIN OR BEHIND A BARRIER CURB, THE TOP OF THE FOUNDATION SHALL BE INSTALLED FLUSH WITH THE TOP OF THE BARRIER CURB.

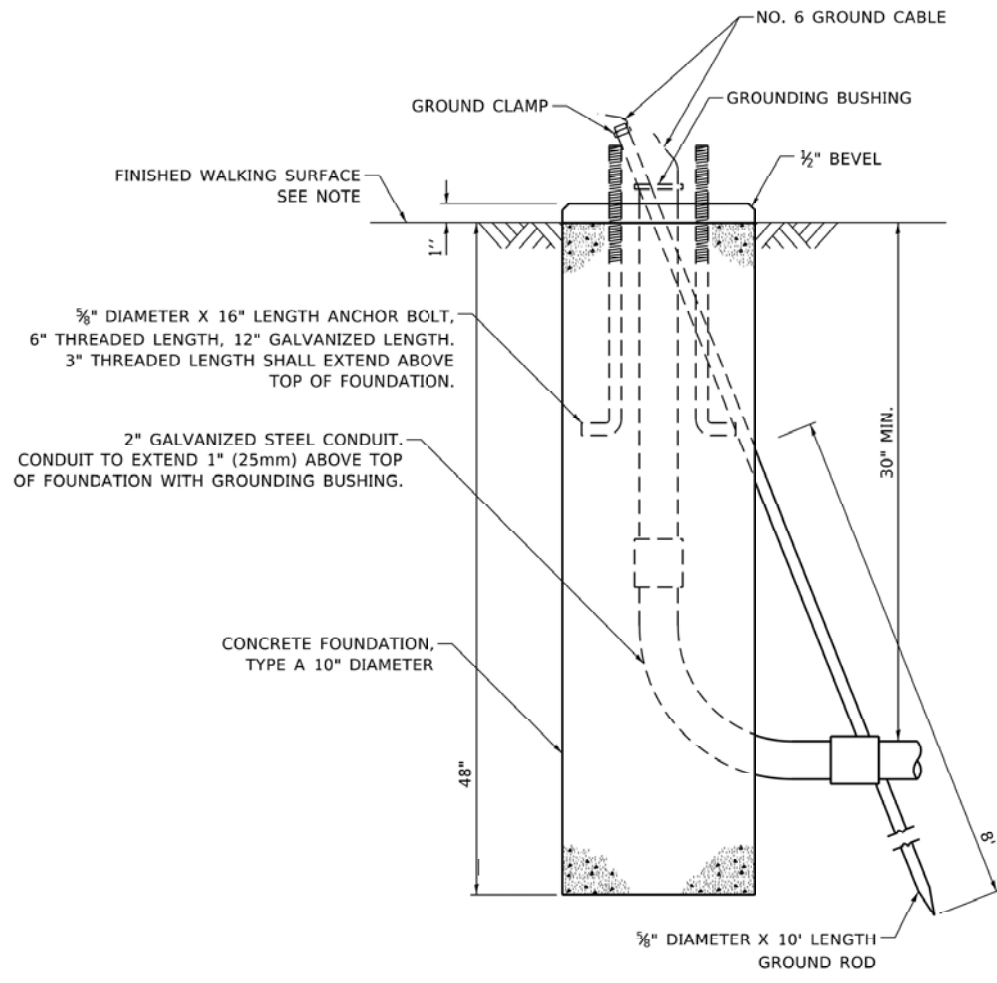

**CONCRETE FOUNDATION,
TYPE A 10-INCH DIAMETER**

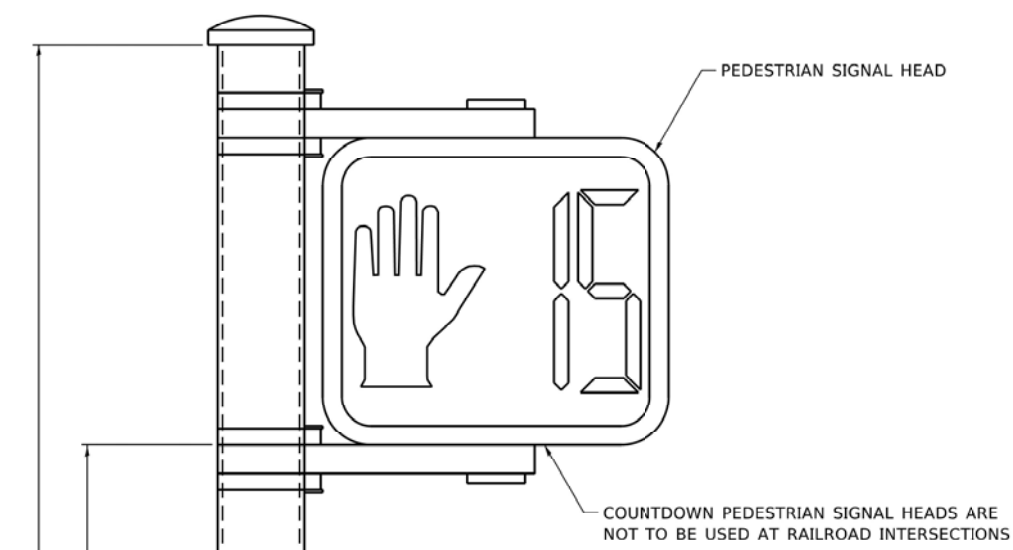

PEDESTRIAN SIGNAL POST, 10 FT.

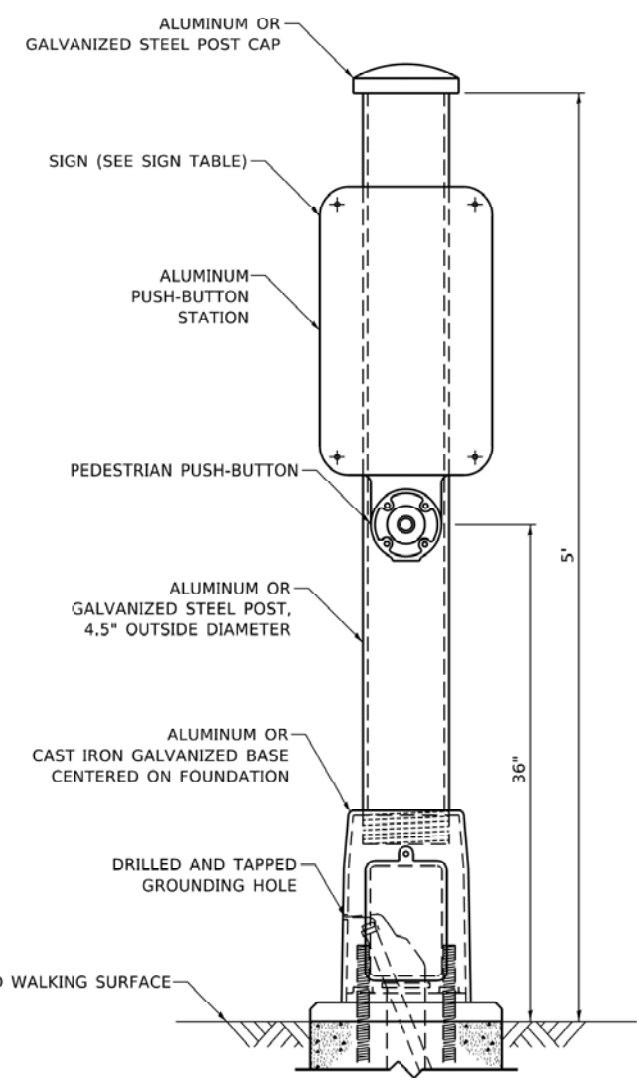

PEDESTRIAN SIGNAL POST, 5 FT.

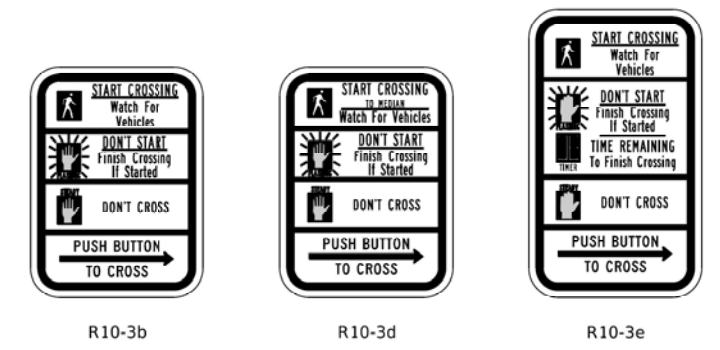

SIGN TABLE

SIGN	DIMENSIONS
R10-3b (RAILROAD ONLY)	9" X 12"
R10-3d (RAILROAD ONLY)	9" X 12"
R10-3e	9" X 15"

NOTES:
1. THE SIGN PANELS SHALL BE TYPE AP SHEETING.
2. THE ARROW ON SIGNS FOR PUSH-BUTTONS SERVING TWO DIRECTIONS ON THE SAME PHASE SHALL BE BI-DIRECTIONAL.
3. THE SIGN FOR DUAL-CALL PUSH-BUTTONS SHALL HAVE NO ARROW.

TS SHT NO. 7

MODEL: D:\dtd\it... FILE NAME: p:\pub\amrcan.dwg... PROJECT: P171909\ICAD\Auto\Traffic\P171909-1141.dwg

USER NAME = koby/kaka	DESIGNED -	REVISED -
PLOT SCALE = 100.0000' / in.	DRAWN -	REVISED -
PLOT DATE = 10/26/2020	CHECKED -	REVISED -
	DATE -	REVISED -

STATE OF ILLINOIS
DEPARTMENT OF TRANSPORTATION

DISTRICT ONE
STANDARD TRAFFIC SIGNAL DESIGN DETAILS
SCALE: NONE SHEET 6 OF 7 SHEETS STA. TO STA.

F.A.P. RTE. 303	SECTION (134 & 134X) N	COUNTY LAKE	TOTAL SHEETS 129	SHEET NO. 73
TS-05		CONTRACT NO. 60V39		
ILLINOIS FED. AID PROJECT				

SIGN PANEL – TYPE 1 OR TYPE 2

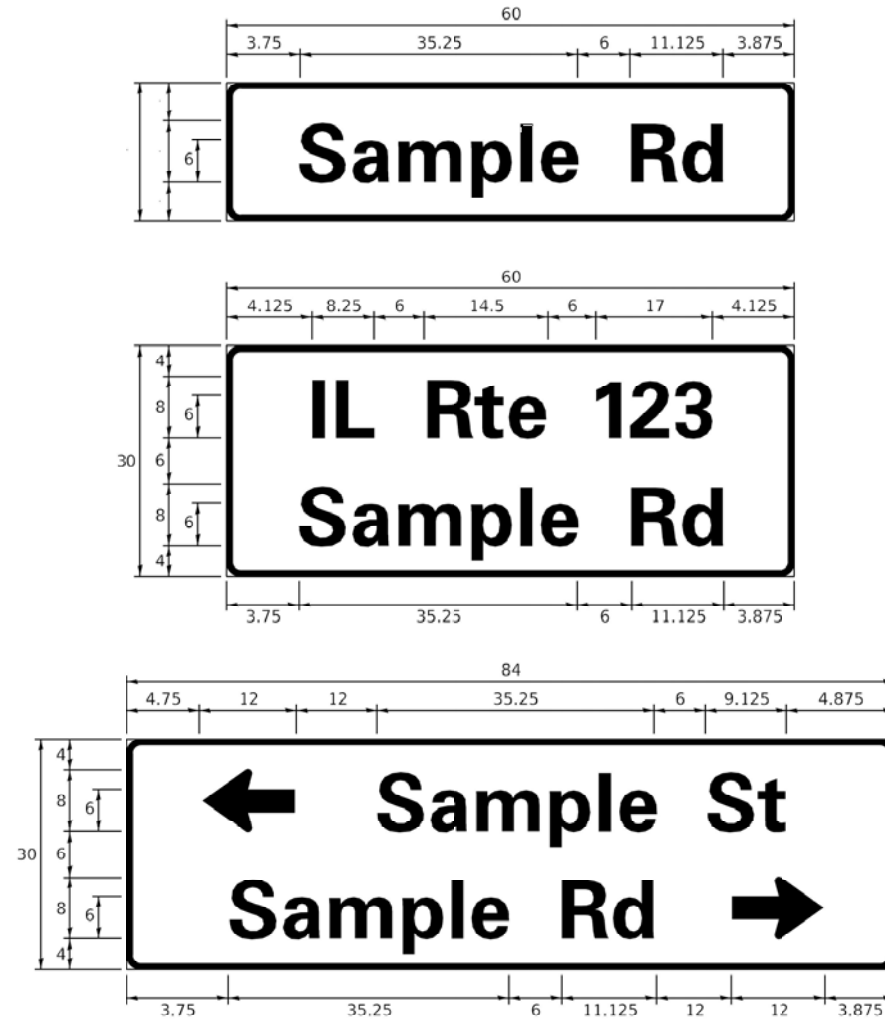

DESIGN SERIES	AREA (SQ FT)	SIGN PANEL TYPE	SHEETING TYPE	QTY. REQUIRED
D OR C	-	1 OR 2	ZZ	-

COMMON STREET NAME ABBREVIATIONS AND WIDTHS

NAME	ABBREVIATION	WIDTH (INCH)	
		SERIES "C"	SERIES "D"
AVENUE	Ave	15.000	18.250
BOULEVARD	Blvd	17.125	20.000
CIRCLE	Cir	11.125	13.000
COURT	Ct	8.250	9.625
DRIVE	Dr	8.625	10.125
HIGHWAY	Hwy	18.375	22.000
ILLINOIS	IL	7.000	8.250
LANE	Ln	9.125	10.750
PARKWAY	Pkwy	23.375	27.375
PLACE	Pl	7.125	7.750
ROAD	Rd	9.625	11.125
ROUTE	Rte	12.625	14.500
STREET	St	8.000	9.125
TERRACE	Ter	12.625	14.625
TRAIL	Tr	7.750	9.125
UNITED STATES	US	10.375	12.250

GENERAL NOTES

- WHERE MAST ARM MOUNTED STREET NAME SIGNS ARE SPECIFIED, THE MAST ARM ASSEMBLY AND POLES SHALL BE DESIGNED TO SUPPORT THE LOADINGS CALLED FOR ON STANDARDS 877001, 877002, 877006, 877011 AND 877012. AS APPLICABLE, PLUS TWO (2) SIGN PANELS 2'-6" x 8'-0" MOUNTED AS SHOWN. THE DESIGN SHALL BE IN ACCORDANCE WITH THE REQUIREMENTS OF THE CURRENT "STANDARD SPECIFICATIONS FOR STRUCTURAL SUPPORTS FOR HIGHWAY SIGNS, LUMINAIRES, AND TRAFFIC SIGNALS" AS PUBLISHED BY THE AMERICAN ASSOCIATION OF STATE HIGHWAY AND TRANSPORTATION OFFICIALS FOR 80 M.P.H. WIND VELOCITY.
- ALL SIGNS SHALL CONSIST OF A WHITE LEGEND AND BORDER (TYPE ZZ SHEETING) ON A GREEN BACKGROUND (TYPE ZZ SHEETING)
- THE SIGN LENGTH SHALL BE IN 6-INCH INCREMENTS, BUT THE OVERALL LENGTH SHALL NOT EXCEED 8'-0". ALL BORDERS IF POSSIBLE, BUT MAY BE REDUCED TO 5" WHEN SPACING IS CRITICAL. A MINIMUM OF 2-1/2" SHALL BE INCLUDED BETWEEN THE WORD AND THE RIGHT AND LEFT EDGES OF THE SIGN.
- A PREFERRED METHOD FOR THE SIGN DESIGN IS TO USE SERIES "D" LETTER ON A ONE-LINE SIGN 18" IN HEIGHT AND A MAXIMUM OF 8'-0" IN WIDTH. IF SERIES "D" DOES NOT FIT ON A 8'-0" SIGN, THEN SERIES "C" SHOULD BE TRIED. IF SERIES "C" DOES NOT FIT ON A 8'-0" SIGN, A 30" HIGH TWO-LINE SIGN CAN BE USED. THE CROSSROAD DESIGNATION AS TO STREET, AVENUE, ETC. SHOULD BE SPELLED OUT ON THE SECOND LINE, IF THE ABBREVIATION CANNOT FIT ON THE FIRST LINE.
- LED ILLUMINATED STREET NAME SIGNS CAN BE USED IN PLACE OF REGULAR SIGN PANELS BUT ANY SPECIAL WORDING AND SYMBOLOGY MUST BE APPROVED BY THE DEPARTMENT. GENERAL DESIGN REQUIREMENT AS LISTED ABOVE (COLOR, FONT, SIZE, ETC.) MUST BE FOLLOWED.
- SIGNFIX ALUMINUM CHANNEL FRAMING SYSTEM SHALL BE USED FOR ALL SIGNS ATTACHED TO SIGNAL POLES AND POSTS.

LOCAL SUPPLIERS:

- J.O. HERBERT COMPANY, INC
MIDLOTHIAN, VA
- WESTERN REMAC, INC.
WOODRIDGE, IL

PARTS LISTING:

- SIGN CHANNEL PART #HPN053 (MED. CHANNEL)
- SIGN SCREWS 1/4" x 14 x 1" H.W.H. #3
- BRACKETS SELF TAPPING WITH NEOPRENE WASHER PART #HPN034 (UNIVERSAL)
- CHANNEL CLAMPS WITH STAINLESS STEEL STRAPPING

OTHER BRANDS OF MOUNTING HARDWARE ARE ACCEPTABLE, BASED UPON THE DEPARTMENT'S APPROVAL AND COMPATIBILITY WITH THE CHANNEL/BACKET OF THE ABOVE PRODUCT.

MOUNTING LOCATION

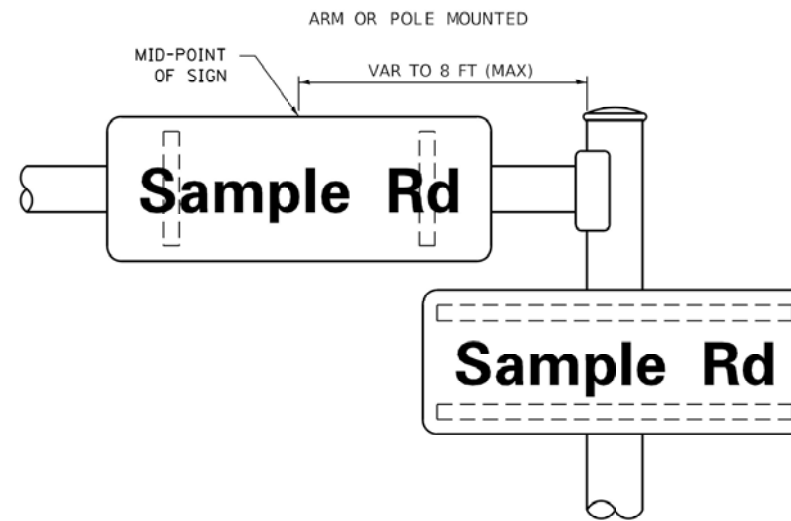

SUPPORTING CHANNELS

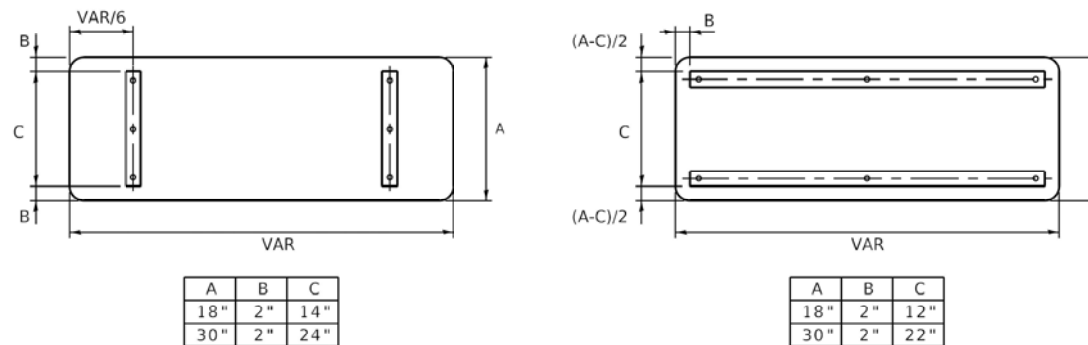

STANDARD ALPHABETS SPACING CHART
(8") UPPER CASE AND (6") LOWER CASE

FHWA SERIES "C"				FHWA SERIES "D"			
CHARACTER	LEFT SPACING (INCH)	WIDTH (INCH)	RIGHT SPACING (INCH)	CHARACTER	LEFT SPACING (INCH)	WIDTH (INCH)	RIGHT SPACING (INCH)
A	0.240	5.122	0.240	A	0.240	6.804	0.240
B	0.880	4.482	0.480	B	0.960	5.446	0.400
C	0.720	4.482	0.720	C	0.800	5.446	0.800
D	0.880	4.482	0.720	D	0.960	5.446	0.800
E	0.880	4.082	0.480	E	0.960	4.962	0.400
F	0.880	4.082	0.240	F	0.960	4.962	0.240
G	0.720	4.482	0.720	G	0.800	5.446	0.800
H	0.880	4.482	0.880	H	0.960	5.446	0.960
I	0.880	1.120	0.880	I	0.960	1.280	0.960
J	0.240	4.082	0.880	J	0.240	5.122	0.960
K	0.880	4.482	0.480	K	0.960	5.604	0.400
L	0.880	4.082	0.240	L	0.960	4.962	0.240
M	0.880	5.284	0.880	M	0.960	6.244	0.960
N	0.880	4.482	0.880	N	0.960	5.446	0.960
O	0.720	4.722	0.720	O	0.800	5.684	0.800
P	0.880	4.482	0.720	P	0.960	5.446	0.240
Q	0.720	4.722	0.720	Q	0.800	5.684	0.800
R	0.880	4.482	0.480	R	0.960	5.446	0.400
S	0.480	4.482	0.480	S	0.400	5.446	0.400
T	0.240	4.082	0.240	T	0.240	4.962	0.240
U	0.880	4.482	0.880	U	0.960	5.446	0.960
V	0.240	4.962	0.240	V	0.240	6.084	0.240
W	0.240	6.084	0.240	W	0.240	7.124	0.240
X	0.240	4.722	0.240	X	0.400	5.446	0.400
Y	0.240	5.122	0.240	Y	0.240	6.884	0.240
Z	0.480	4.482	0.480	Z	0.400	5.446	0.400
a	0.320	3.842	0.640	a	0.400	4.562	0.720
b	0.720	4.082	0.480	b	0.800	4.802	0.480
c	0.480	4.002	0.240	c	0.480	4.722	0.240
d	0.480	4.082	0.720	d	0.480	4.802	0.800
e	0.480	4.082	0.320	e	0.480	4.722	0.320
f	0.320	2.480	0.160	f	0.320	2.882	0.160
g	0.480	4.082	0.720	g	0.480	4.802	0.800
h	0.720	4.082	0.640	h	0.800	4.722	0.720
i	0.720	1.120	0.720	i	0.800	1.280	0.800
j	0.000	2.320	0.720	j	0.000	2.642	0.800
k	0.720	4.322	0.160	k	0.800	5.122	0.160
l	0.720	1.120	0.720	l	0.800	1.280	0.800
m	0.720	6.724	0.640	m	0.800	7.926	0.720
n	0.720	4.082	0.640	n	0.800	4.722	0.720
o	0.480	4.082	0.480	o	0.480	4.882	0.480
p	0.720	4.082	0.480	p	0.800	4.802	0.480
q	0.480	4.082	0.720	q	0.480	4.802	0.800
r	0.720	2.642	0.160	r	0.800	3.042	0.160
s	0.320	3.362	0.240	s	0.320	3.762	0.240
t	0.080	2.882	0.080	t	0.080	3.202	0.080
u	0.640	4.082	0.720	u	0.720	4.722	0.800
v	0.160	4.722	0.160	v	0.160	5.684	0.160
w	0.160	7.524	0.160	w	0.160	9.046	0.160
x	0.000	5.202	0.000	x	0.000	6.244	0.000
y	0.160	4.952	0.160	y	0.160	6.004	0.160
z	0.240	3.362	0.240	z	0.240	4.002	0.240
1	0.720	1.630	0.880	1	0.800	2.000	0.960
2	0.480	4.482	0.480	2	0.800	5.446	0.800
3	0.480	4.482	0.480	3	1.440	5.446	0.800
4	0.240	4.952	0.720	4	0.160	6.004	0.960
5	0.480	4.482	0.480	5	0.800	5.446	0.800
6	0.720	4.482	0.720	6	0.800	5.446	0.800
7	0.240	4.482	0.720	7	0.560	5.446	0.560
8	0.480	4.482	0.480	8	0.800	5.446	0.800
9	0.480	4.482	0.480	9	0.800	5.446	0.800
0	0.720	4.722	0.720	0	0.800	5.684	0.800
-	0.240	2.802	0.240	-	0.240	2.802	0.240

TS SHT NO. 8

MODEL: D:\detroit\p11909\CD\Drawn\Traffic\p11909-sht-8.dgn

USER NAME = koby/kaka	DESIGNED - LP/IP	REVISED - LP 07/01/2015
PLOT SCALE = 100.0000' / in.	CHECKED - IP	REVISED -
PLOT DATE = 10/26/2020	DATE - 10/01/2014	REVISED -

STATE OF ILLINOIS
DEPARTMENT OF TRANSPORTATION

DISTRICT ONE
MAST ARM MOUNTED STREET NAME SIGNS

SCALE: SHEET OF SHEETS STA. TO STA.

F.A.P. RTE. 303	SECTION (134 & 134X) N	COUNTY LAKE	TOTAL SHEETS 129	SHEET NO. 74
TS-02		CONTRACT NO. 60V39		
ILLINOIS FED. AID PROJECT				

NOTES:

1. EACH DETECTOR LOOP SHALL HAVE ITS OWN 1" COILABLE NON-METALLIC CONDUIT BETWEEN THE EDGE OF PAVEMENT AND THE ADJACENT HANDHOLE AS SHOWN ON THE PLANS AND AS STATED IN THE TRAFFIC SIGNAL SPECIFICATIONS.
2. TWO CHANGEABLE MESSAGE SIGNS ON IL RTE 173 WILL NEED TO BE IN PLACE TWO WEEKS PRIOR AND TWO WEEKS AFTER THE TRAFFIC SIGNAL IS TURNED-ON. THIS IS REQUIRED FOR A NEW STOP CONDITION.
3. EMERGENCY VEHICLE PRIORITY LIGHT DETECTOR MOUNTING CONFIGURATIONS SHALL BE SUCH AS TO MAXIMIZE CLEAR LINE OF DETECTION RANGE.
4. NEW PTZ CAMERA TO BE MOUNTED ON THE COMBINATION MAST ARM LUMINARE ARM.
5. THE CONTRACTOR SHALL BE AWARE THAT WET-METHOD DRILLING, TEMPORARY CASING, OR A COMBINATION MAY BE REQUIRED TO PREVENT A CAVE-IN DURING FOUNDATION SHAFT DRILLING.

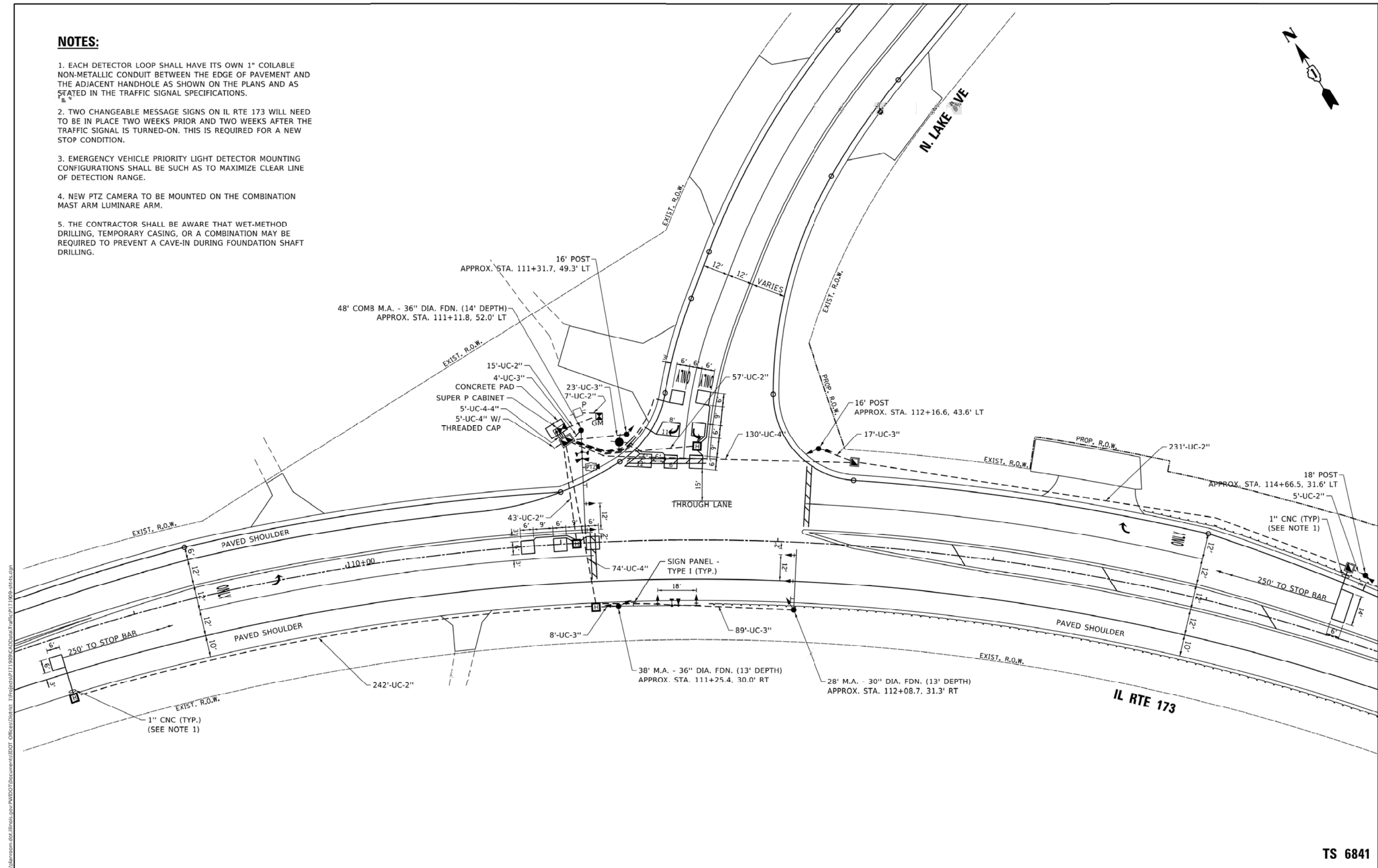
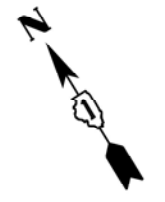

TS SHT NO. 9

TS 6841

MODEL: D:\draft\...
 FILE NAME: p:\pub\amrcan.dwg
 I:\projects\171909\CD\DrawnTraffic\171909-ats.dwg

USER NAME = koby/kaka	DESIGNED JRD	REVISED KK - 01-06-2020
	DRAWN ZCW	REVISED KK - 10-26-2020
PLOT SCALE = 40.0000' / 1"	CHECKED KLB	REVISED
PLOT DATE = 10/26/2020	DATE 11/7/2013	REVISED

**STATE OF ILLINOIS
DEPARTMENT OF TRANSPORTATION**

TRAFFIC SIGNAL INSTALLATION PLAN	
IL RTE 173 AT NORTH LAKE AVENUE	
SCALE: 1"=20'	SHEET OF SHEETS STA. TO STA.

F.A.P. RTE. 303	SECTION (134 & 134X) N	COUNTY LAKE	TOTAL SHEETS 129	SHEET NO. 75
CONTRACT NO. 60V39			ILLINOIS FED. AID PROJECT	

SCHEDULE OF QUANTITIES

ITEM DESCRIPTION	UNITS	TOTAL QTY
CHANGEABLE MESSAGE SIGN	CAL DA	60
SIGN PANEL - TYPE 1	SQ FT	25.5
UNDERGROUND CONDUIT, GALVANIZED STEEL, 2" DIA.	FOOT	600
UNDERGROUND CONDUIT, GALVANIZED STEEL, 3" DIA.	FOOT	141
UNDERGROUND CONDUIT, GALVANIZED STEEL, 4" DIA.	FOOT	229
HANDHOLE	EACH	2
HEAVY-DUTY HANDHOLE	EACH	4
DOUBLE HANDHOLE	EACH	1
ELECTRIC CABLE IN CONDUIT, SIGNAL NO. 14 3C	FOOT	260
ELECTRIC CABLE IN CONDUIT, SIGNAL NO. 14 5C	FOOT	1,190
ELECTRIC CABLE IN CONDUIT, SIGNAL NO. 14 7C	FOOT	720
ELECTRIC CABLE IN CONDUIT, LEAD-IN, NO. 14 1 PAIR	FOOT	930
ELECTRIC CABLE IN CONDUIT, SERVICE, NO. 6 2 C	FOOT	65
ELECTRIC CABLE IN CONDUIT, EQUIPMENT GROUNDING CONDUCTOR, NO. 6 1C	FOOT	753
TRAFFIC SIGNAL POST, GALVANIZED STEEL 16 FT.	EACH	2
* TRAFFIC SIGNAL POST, GALVANIZED STEEL 18 FT.	EACH	1
STEEL MAST ARM ASSEMBLY AND POLE, 28 FT.	EACH	1
STEEL MAST ARM ASSEMBLY AND POLE, 38 FT.	EACH	1
STEEL COMBINATION MAST ARM ASSEMBLY AND POLE 48 FT.	EACH	1
CONCRETE FOUNDATION, TYPE A	FOOT	16
CONCRETE FOUNDATION, TYPE C	FOOT	4
CONCRETE FOUNDATION, TYPE E 30-INCH DIAMETER	FOOT	13
CONCRETE FOUNDATION, TYPE E 36-INCH DIAMETER	FOOT	27
SIGNAL HEAD, LED, 1-FACE, 3-SECTION, MAST-ARM MOUNTED	EACH	4
SIGNAL HEAD, LED, 1-FACE, 3-SECTION, BRACKET MOUNTED	EACH	4
SIGNAL HEAD, LED, 1-FACE, 5-SECTION, BRACKET MOUNTED	EACH	2
SIGNAL HEAD, LED, 1-FACE, 5-SECTION, MAST-ARM MOUNTED	EACH	2
TRAFFIC SIGNAL BACKPLATE, LOUVERED, FORMED PLASTIC	EACH	6
INDUCTIVE LOOP DETECTOR	EACH	5
DETECTOR LOOP, TYPE I	FOOT	395
* LIGHT DETECTOR	EACH	3
* LIGHT DETECTOR AMPLIFIER	EACH	1
* EMERGENCY VEHICLE PRIORITY SYSTEM LINE SENSOR CABLE, NO. 20 3/C	FOOT	682
FULL-ACTUATED CONTROLLER AND TYPE SUPER P CABINET	EACH	1
SERVICE INSTALLATION, GROUND MOUNTED, METERED	EACH	1
UNINTERRUPTIBLE POWER SUPPLY, SPECIAL	EACH	1
** CELLULAR MODEM	EACH	1
** OUTDOOR RATED NETWORK CABLE	FOOT	92
** REMOTE CONTROLLED VIDEO SYSTEM	EACH	1

* 100% COST TO THE ANTIOCH FIRE DEPARTMENT
 ** 100% COST TO LAKE COUNTY DIVISION OF TRANSPORTATION

SIGN PANEL - TYPE 1 OR TYPE 2

ALL DIMENSIONS ARE IN INCHES UNLESS NOTED OTHERWISE

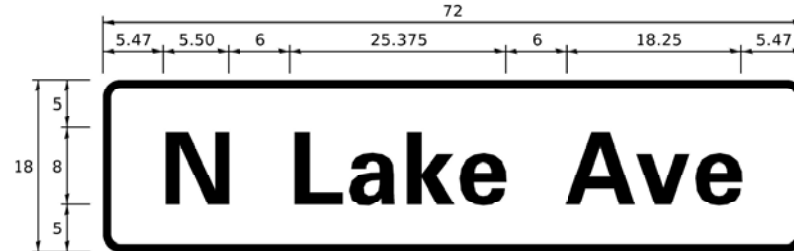

DESIGN SERIES	AREA (SQ FT)	SIGN PANEL TYPE	SHEETING TYPE	QTY REQUIRED
D	9.00	1	ZZ	2

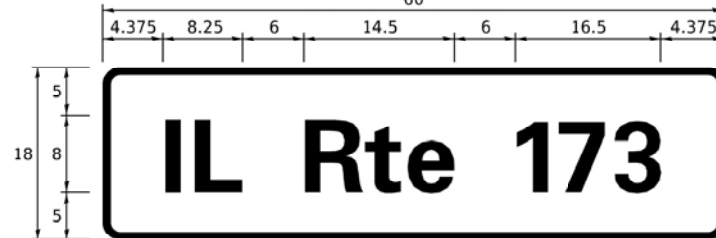

DESIGN SERIES	AREA (SQ FT)	SIGN PANEL TYPE	SHEETING TYPE	QTY REQUIRED
D	7.5	1	ZZ	1

NOTE: FOR ADDITIONAL DESIGN AND INSTALLATION INFORMATION PLEASE SEE DISTRICT ONE MAST ARM MOUNTED STREET NAME SIGNS DETAIL.

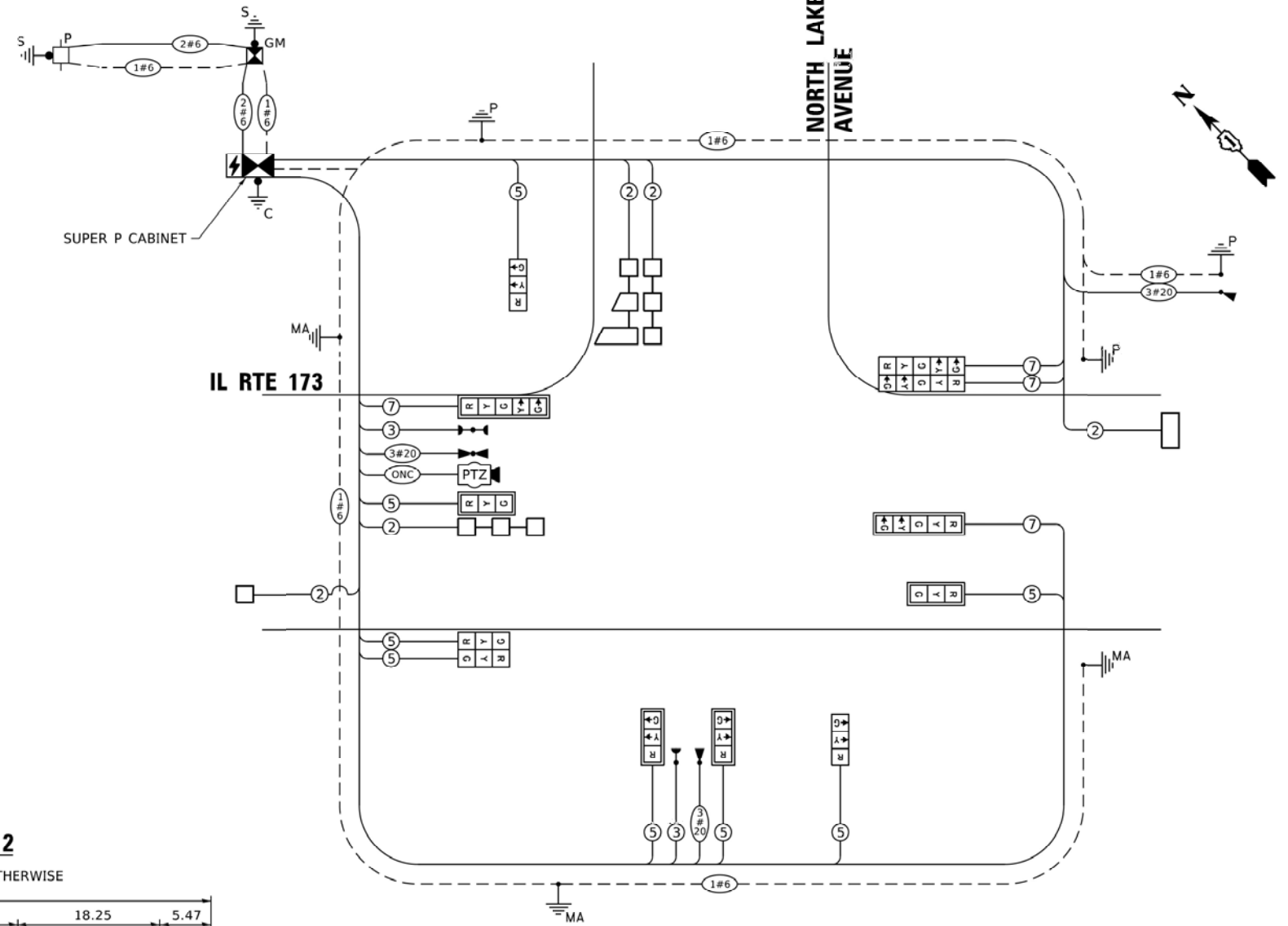

CABLE PLAN

PROPOSED CONTROLLER SEQUENCE

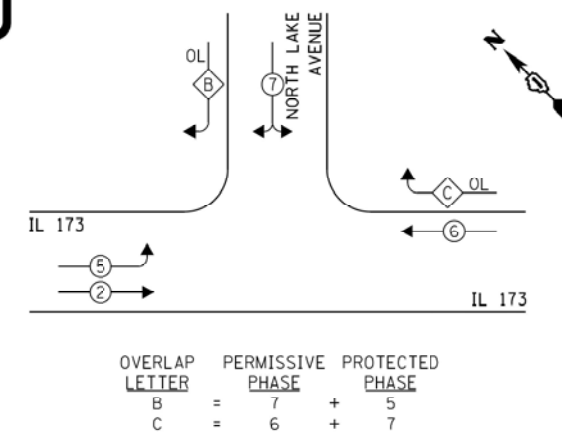

OVERLAP LETTER PERMISSIVE PHASE PROTECTED PHASE
 B = 7 + 5
 C = 6 + 7

PROPOSED EMERGENCY VEHICLE PREEMPTION SEQUENCE

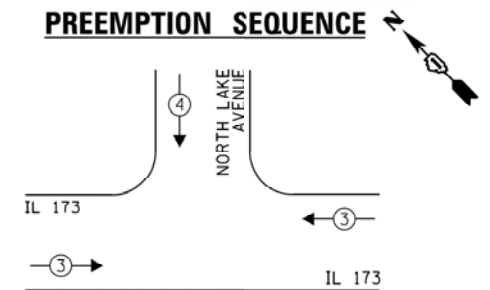

LEGEND:

- ← (circle with star) → PROTECTED PHASE
- ← (circle with star) - (circle with star) → PROTECTED/PERMITTED PHASE
- ← (circle with star) → (circle with star) → PEDESTRIAN PHASE
- ← (circle with star) OL (circle with star) → OVERLAP

EMERGENCY VEHICLE PREEMPTORS	
EMERGENCY VEHICLE PREEMPTOR	3 4
MOVEMENT	← →

TS 6841

TRAFFIC SIGNAL ELECTRICAL SERVICE REQUIREMENTS

TYPE	NO. OF LAMPS	LED WATTAGE	% OPERATION	TOTAL WATTAGE
SIGNAL (RED)	12	11	50	66.0
(YELLOW)	12	20	5	12.0
(GREEN)	12	12	45	64.8
PERMISSIVE ARROW	8	10	10	8.0
PED. SIGNAL	-	20	100	-
CONTROLLER	1	100	100	100.0
UPS	1	25	100	25.0
VIDEO SYSTEM	-	150	100	-
BLANK-OUT SIGN	-	25	5	-
FLASHER	-	-	50	-
STREET NAME SIGN	-	20	50	-
LUMINAIRE	-	-	-	-
TOTAL =				275.8

ENERGY COSTS TO:

VILLAGE OF ANTIOCH
 874 MAIN STREET
 ANTIOCH, IL 60002

ENERGY SUPPLY: CONTACT: TERRI BLECK
 PHONE: (847) 816-5239
 COMPANY: COMMONWEALTH EDISON
 ACCOUNT NUMBER: 72111-40007

USER NAME = koby/kaka	DESIGNED JRD	REVISED KK - 01-06-2020
PLOT SCALE = 40.0000' / 1"	DRAWN ZCW	REVISED KK - 10-26-2020
PLOT DATE = 10/26/2020	CHECKED KLB	REVISED
	DATE 11/7/2013	REVISED

**STATE OF ILLINOIS
 DEPARTMENT OF TRANSPORTATION**

**CABLE PLAN, PHASE DESIGNATION, SCHEDULE OF QUANTITIES
 MAST ARM MOUNTED STREET NAME SIGNS
 IL RTE 173 AT NORTH LAKE AVENUE**

SCALE: 1"=20' SHEET OF SHEETS STA. TO STA.

F.A.P. RTE.	SECTION	COUNTY	TOTAL SHEETS	SHEET NO.
303	(134 & 134X) N	LAKE	129	76
CONTRACT NO. 60V39				
ILLINOIS FED. AID PROJECT				

TS SHT NO. 10

MODEL: D:\dwg\... FILE NAME: p:\work\... OFFICE: ...

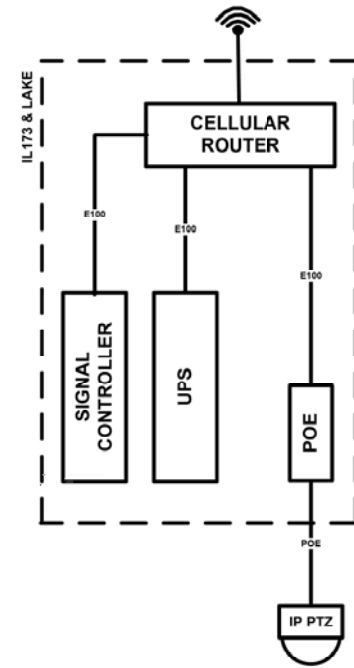

DESIGNED - DG	REVISED -
DRAWN - YM	REVISED -
CHECKED - DG	REVISED -
DATE 2020.03.30	REVISED -

LAKE COUNTY
DIVISION OF TRANSPORTATION

240B
IL173 & LAKE CABINET DETAIL

JOB	ROUTE	ROUTE SECTION	SHEET	SHEETS
60V39	303	(134 & 134X) N	88A	

SCALE: N/A

TS SHT NO. 11

MODEL: Default
FILE: North Drive\blm\com.dpt.illinois.gov\PROJECTS\Documents\DOT_Offices\lbrk\171909\ICAD\lbrk\Traffic\171909-sht11.dgn

USER NAME = koby/kaka	DESIGNED JRD	REVISED KK - 01-06-2020
	DRAWN ZCW	REVISED KK - 10-26-2020
PLOT SCALE = 40.0000 * / 1%	CHECKED KLB	REVISED
PLOT DATE = 10/26/2020	DATE 11/7/2013	REVISED

STATE OF ILLINOIS
DEPARTMENT OF TRANSPORTATION

LAKE COUNTY CELLULAR MODEM SHEMATIC
IL RTE 173 AT NORTH LAKE AVENUE

SCALE: 1"=20' SHEET OF SHEETS STA. TO STA.

F.A.P. RTE.	SECTION	COUNTY	TOTAL SHEETS	SHEET NO.
303	(134 & 134X) N	LAKE	129	77
CONTRACT NO. 60V39				
ILLINOIS FED. AID PROJECT				

TS 6841

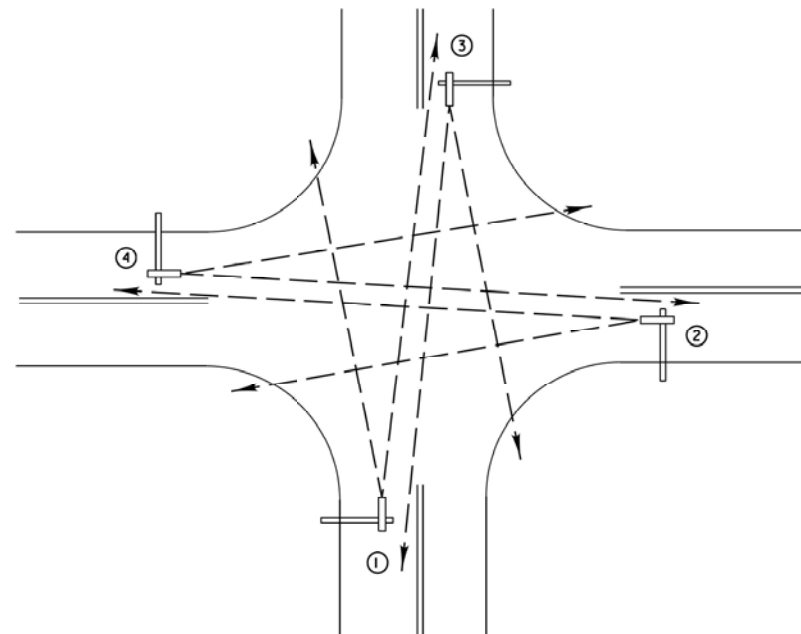

TYPICAL VIDEO VEHICLE DETECTION SYSTEM
(NOT TO SCALE)

(4) VIDEO DETECTION CAMERA ASSEMBLIES AND BRACKETS ① ② ③ ④

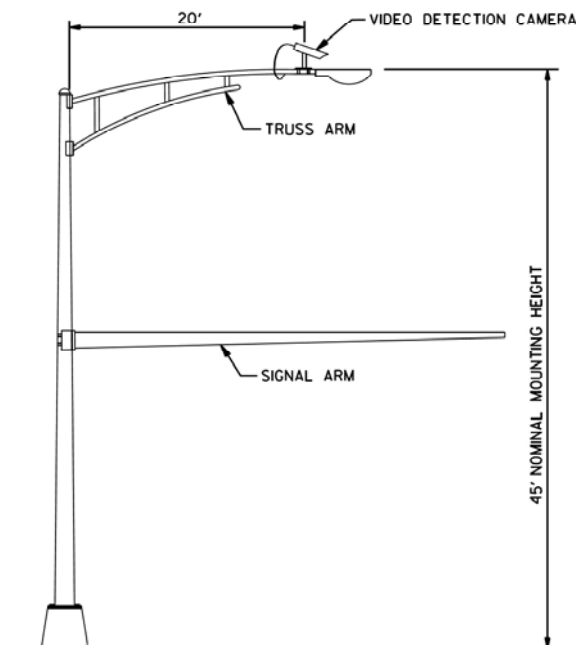

COMBINATION MAST ARM ASSEMBLY AND POLE DIMENSIONS
(NOT TO SCALE)

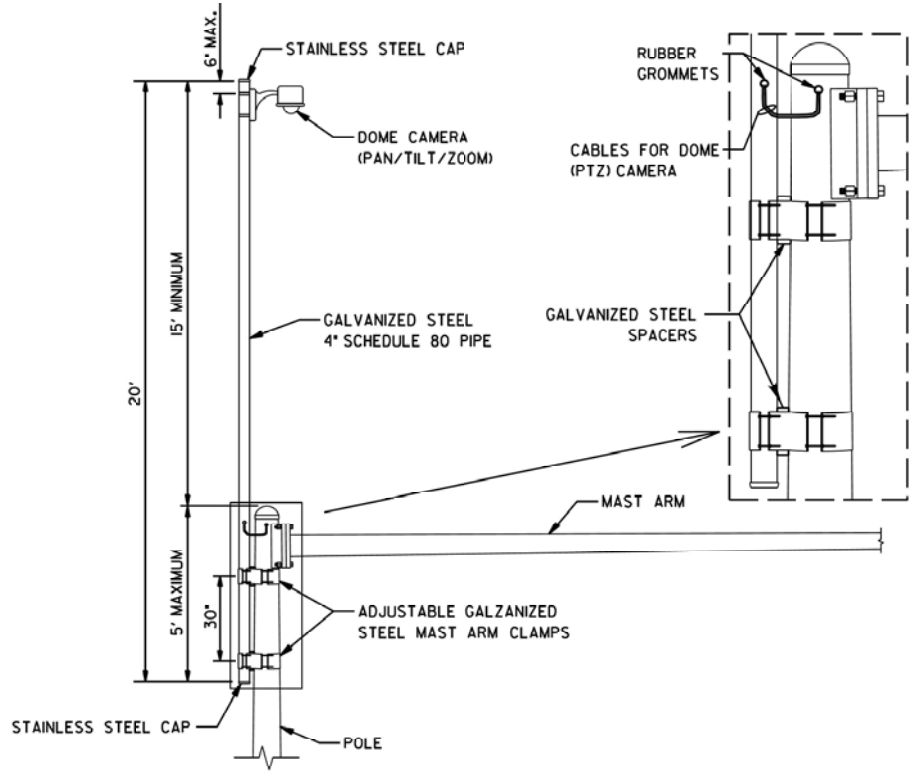

CAMERA MOUNTING ASSEMBLY DETAIL
(NOT TO SCALE)

- NOTES:**
- THE MAST ARM IS TAPERED.
 - INSTALL EXTENSION POLE VERTICAL AND PLUMB BY MODIFYING/INSTALLING BRACKETS AS NECESSARY. ADDITIONAL SPACERS REQUIRED ARE INCLUDED IN THE COST OF THE CAMERA MOUNTING ASSEMBLY OF THE TYPE SPECIFIED.
 - SPACERS ARE TO BE INTEGRATED OR MANUFACTURED WITH THE MAST ARM BRACKETS

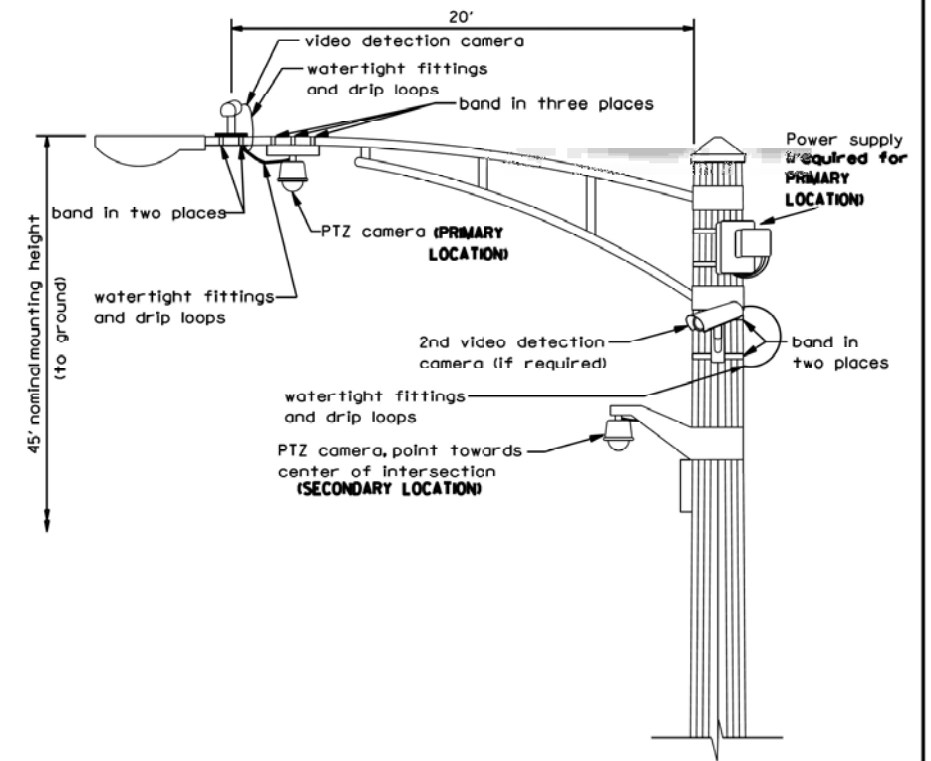

VIDEO DETECTION CAMERA(S) AND DOME (PTZ) CAMERA MOUNTING DETAIL
(NOT TO SCALE)

- NOTES FOR SINGLE, DUAL AND MULTIPLE CAMERA MOUNTING:**
- MOUNT LUMINAIRE MOUNTING BRACKET AS HIGH AS POSSIBLE.
 - MOUNT VIDEO DETECTION CAMERA AS HIGH AS POSSIBLE DOWN TOWARD THE DIRECTION OF TRAFFIC TO BE DETECTED.

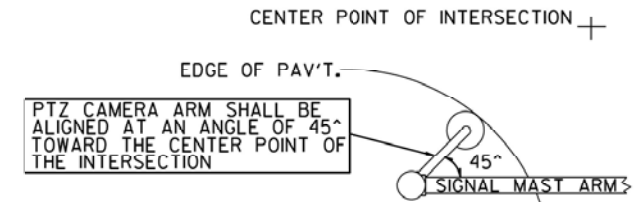

PTZ CAMERA MOUNTING DETAILS (SECONDARY LOCATION)
(NO SCALE)

REVISIONS	DATE
Mounting Details Revised	05/01/08
2nd Camera Locat. added	01/14/09
Mast Arm Taper Detail	06/01/12
Mounting Details Revised	06/13/14



APPROVED BY: J. P. NELSON
DATE: JUNE 13, 2014

CAMERA MOUNTING DETAILS

LC8900

NO.	DESCRIPTION	DATE	BY	SURVEYOR



PROJECT NAME
LAKE COUNTY STANDARDS & DETAILS

ROUTE	SECTION	SECTION NUMBER	SHEET	SHEETS
CHXX	XXX	XX-XXXXX-XX-XX	XXX	XXX

FILE NAME: C:\Users\hdmrc\Desktop\LC8900 VIDEO DETECTION DETAILS REVISION-JUNE 2014.DGN

USER NAME = koby/kaka	DESIGNED JRD	REVISED KK - 01-06-2020
	DRAWN ZCW	REVISED KK - 10-26-2020
PLOT SCALE = 40.0000' / 1"	CHECKED KLB	REVISED
PLOT DATE = 10/26/2020	DATE 11/7/2013	REVISED

STATE OF ILLINOIS
DEPARTMENT OF TRANSPORTATION

CAMERA MOUNTING DETAILS
IL RTE 173 AT NORTH LAKE AVENUE

SCALE: 1"=20' SHEET OF SHEETS STA. TO STA.

F.A.P. RTE.	SECTION	COUNTY	TOTAL SHEETS	SHEET NO.
303	(134 & 134X) N	LAKE	129	78

CONTRACT NO. 60V39
ILLINOIS FED. AID PROJECT

TS SHT NO. 12

MODEL: D:\dait... FILE NAME: p:\hdmrc\proj\LC8900\Documents\DOT_Offices\Detail_1\Project\171909\LC8900\Traffic\171909-sht-12.dgn

Benchmark: Control Points (CP) #104 and #106

CP #104 - Set Iron Rod with cap. Located in the north-east corner of the intersection of IL 173 and Lake Ave. Refer to Alignment, Ties & Benchmarks sheet for tie information. Elevation 747.26.

CP #106 - Set Iron Rod with cap. Located on the west side of IL 173. Refer to Alignment, Ties & Benchmarks sheet for tie information. Elevation 771.61

Proposed Structures: Permanent steel sheet pile walls RW-1 & RW-2 from Sta. 115+49.11 to Sta. 119+20.00 and Sta. 112+33.28 to Sta. 119+70.00, respectively.

Existing Structure: None.

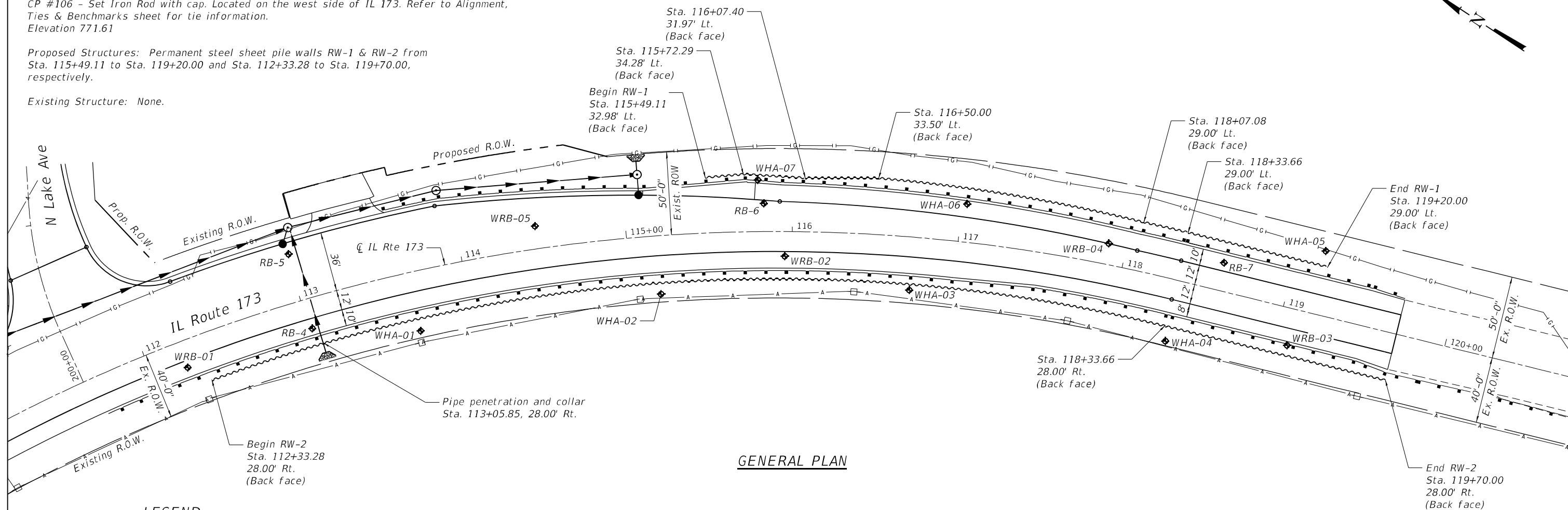

GENERAL PLAN

LEGEND

- ◆ Soil Boring Location
- Existing Utility Pole
- Existing Aerial Line
- Existing Gas Line
- ~ Proposed Retaining Wall
- Proposed Guardrail
- Proposed Storm Sewer Line
- Proposed Drainage Structures

I certify that to be the best of my knowledge, information and belief, this bridge design is structurally adequate for the design loading shown on the plans. The design is an economical one for the style of structure and complies with requirements of the current "AASHTO LRFD Specifications."

Signed: *Jia Wang*

Dated: 03/08/2021

Illinois Structural Engineer
No. 081-006586
License Expires: 11-30-2022

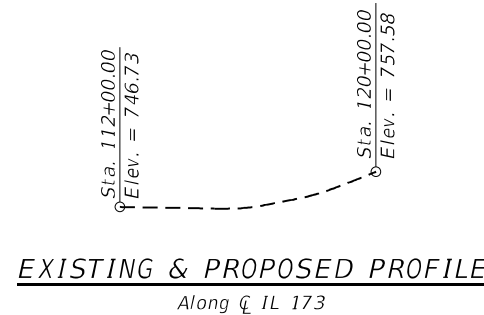
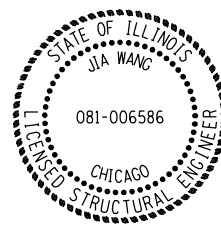

EXISTING & PROPOSED PROFILE
Along CL IL 173

DESIGN SPECIFICATIONS
2020 AASHTO LRFD Bridge Design Specifications, 9th Edition

DESIGN STRESSES
FIELD UNITS

$f'_c = 3,500$ psi
 $f_y = 60,000$ psi (Reinforcement)
 $f_y = 50,000$ psi (M202 Grade 50) (Steel Piles)

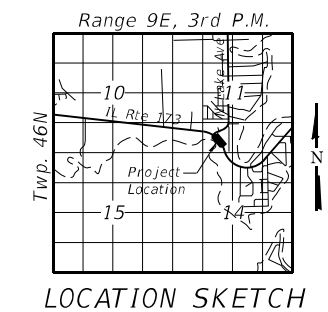

RETAINING WALLS GENERAL PLAN
IL RTE 173
SECTION NO. (134&134X)N
LAKE COUNTY

STA. 115+49.11 (RW-1) & STA. 112+33.28 (RW-2)

MODEL: Default
FILE NAME: P:\19-1137.08 IL173-LakeStn0_IDOT\Structures\DOT\xxxxx_001_General Plan & Data.dgn



USER NAME =	ndp	DESIGNED -	MLC	REVISED -	_____
PLOT SCALE =	N/A	CHECKED -	JW	REVISED -	_____
PLOT DATE =	3/8/2021	DRAWN -	NDP	REVISED -	_____
		CHECKED -	JW	REVISED -	_____

STATE OF ILLINOIS
DEPARTMENT OF TRANSPORTATION

IL RTE 173 PERMANENT STEEL SHEET PILE RETAINING WALLS
RETAINING WALLS GENERAL PLAN

SHEET 1 OF 18 SHEETS

F.A.P. RTE.	SECTION	COUNTY	TOTAL SHEETS	SHEET NO.
303	(134&134X)N	LAKE	129	79
CONTRACT NO. 60V39				
ILLINOIS FED. AID PROJECT				

GENERAL NOTES

1. Reinforcement bars designated (E) shall be epoxy coated.
2. Exposed edges shall be beveled 1".
3. The Contractor shall use care when excavating around existing utilities. Any damage caused to existing facilities shall be repaired or replaced at the Contractor's expense.
4. If the Contractor chooses to alter the sheet piling design requirements shown in these plans for lesser design requirements, then full design submittal including plan details and sealed calculations by an Illinois licensed structural engineer will be required for review and acceptance by the Engineer.
5. The Contractor shall verify all utilities prior to driving sheet piles.
6. The Contractor shall use care while driving sheet piles due to presence of overhead utility lines.

INDEX OF SHEETS

- | | |
|-------|---|
| 1 | Retaining Walls General Plan |
| 2 | General Notes & Total Bill of Materials |
| 3 | RW-1 General Plan & Elevation - 1 |
| 4 | RW-1 General Plan & Elevation - 2 |
| 5 | RW-2 General Plan & Elevation - 1 |
| 6 | RW-2 General Plan & Elevation - 2 |
| 7 | RW-2 General Plan & Elevation - 3 |
| 8 | RW-2 General Plan & Elevation - 4 |
| 9 | Drainage Pipe Penetration Details |
| 10-18 | Soil Boring Logs |

WALL RW-1 BILL OF MATERIAL

ITEM	UNIT	TOTAL
Permanent Sheet Piling	Sq. Ft.	15,787

WALL RW-2 BILL OF MATERIAL

ITEM	UNIT	TOTAL
Concrete Structures	Cu. Yd.	0.9
Stud Shear Connectors	Each	10
Reinforcement Bars, Epoxy Coated	Pound	80
Permanent Sheet Piling	Sq. Ft.	26,385

MODEL: D:\faulr FILE NAME: P:\19-1137.08 IL173-Lake510_IDOT\Structures\10xxxxx_002_General Notes.dgn



Kaskaskia
Engineering Group, LLC
Professional Engineering Group

200 E. Main St., Suite 200
Moline, IL 61704
662.333.8877 phone
662.333.8877 fax
www.kaskaskiaeng.com

11/27/2013
01-000004

USER NAME = mcohen	DESIGNED - MLC	REVISED -
PLOT SCALE = N/A	CHECKED - JW	REVISED -
PLOT DATE = 01/22/21	DRAWN - NDP	REVISED -
	CHECKED - JW	REVISED -

STATE OF ILLINOIS
DEPARTMENT OF TRANSPORTATION

IL RTE 173 PERMANENT STEEL SHEET PILE RETAINING WALLS
GENERAL NOTES & TOTAL BILL OF MATERIALS

SHEET 2 OF 18 SHEETS

F.A.P. RTE.	SECTION	COUNTY	TOTAL SHEETS	SHEET NO.
303	(134&134X)N	LAKE	129	80
CONTRACT NO. 60V39				
ILLINOIS FED. AID PROJECT				

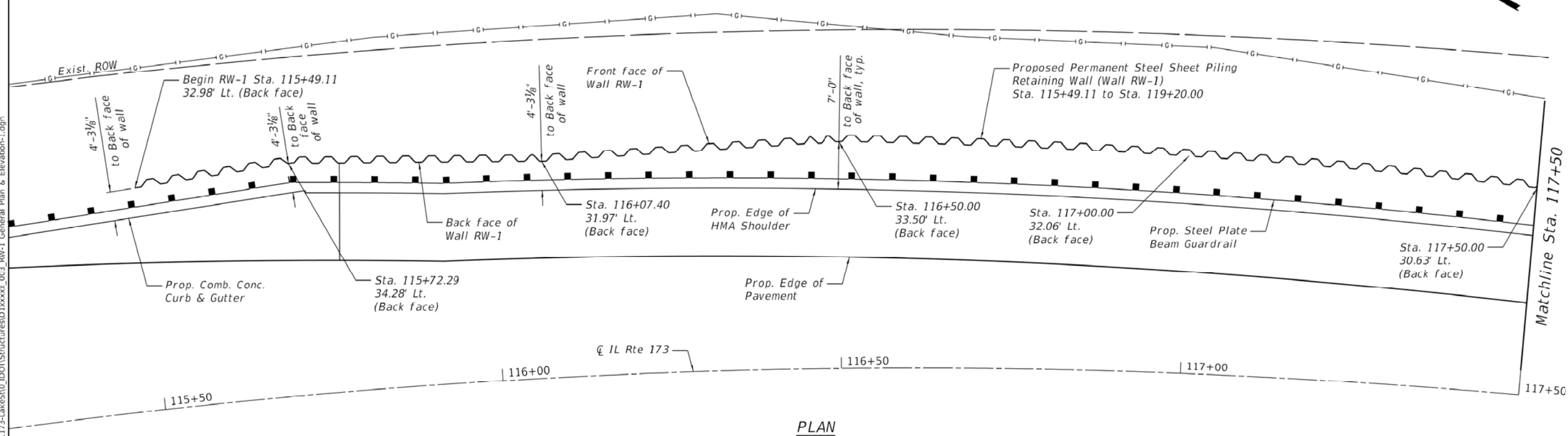
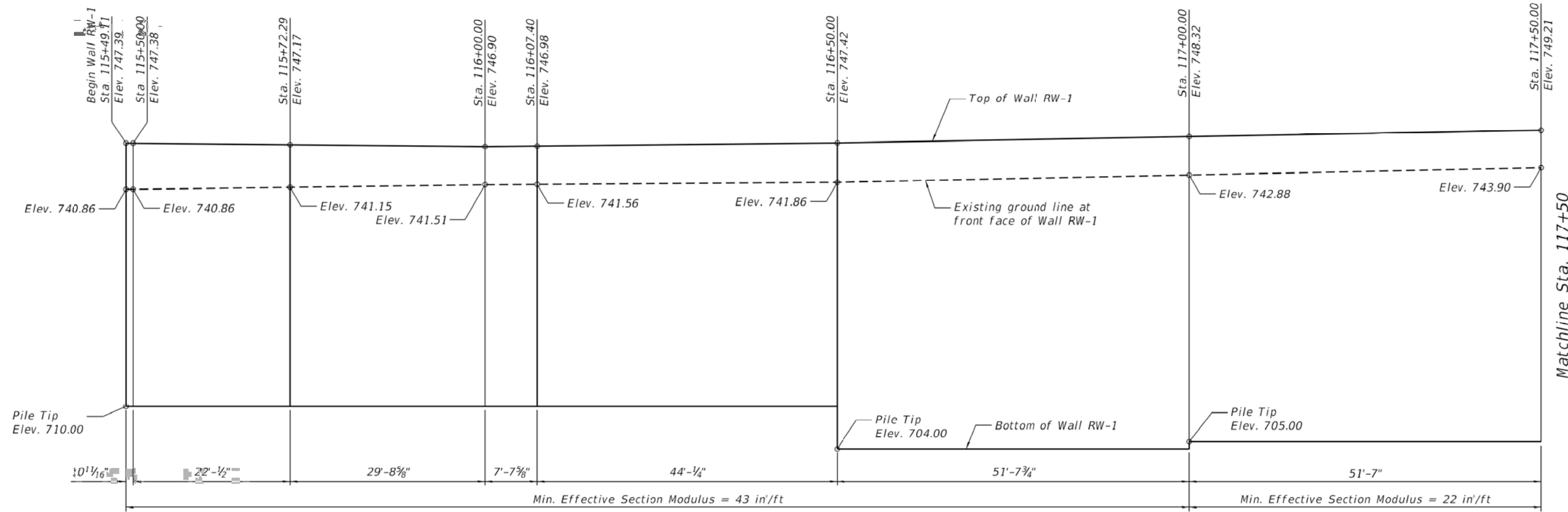

MODEL: D:\faulk\ Kaskaskia Engineering Group, LLC
 FILE NAME: P:\19-1137.08 IL173-Lake510_IDOT\Structures\03_RW-1 General Plan & Elevation-1.dgn
 01/22/21 2:10:28 PM

Kaskaskia Engineering Group, LLC
 200 E. Main St., Suite 200
 Moline, IL 61704
 309.253.0877
 309.253.0877 fax
 www.kaskaskiaeng.com

USER NAME = mcohen	DESIGNED - MLC	REVISD -
PLOT SCALE = N/A	CHECKED - JW	REVISD -
PLOT DATE = 01/22/21	DRAWN - NDP	REVISD -
	CHECKED - JW	REVISD -

STATE OF ILLINOIS
DEPARTMENT OF TRANSPORTATION

IL RTE 173 PERMANENT STEEL SHEET PILE RETAINING WALLS
WALL RW-1 GENERAL PLAN & ELEVATION - 1

F.A.P. RTE. 303	SECTION (134&134X)N	COUNTY LAKE	TOTAL SHEETS 129	SHEET NO. 81
CONTRACT NO. 60V39				
ILLINOIS FED. AID PROJECT				

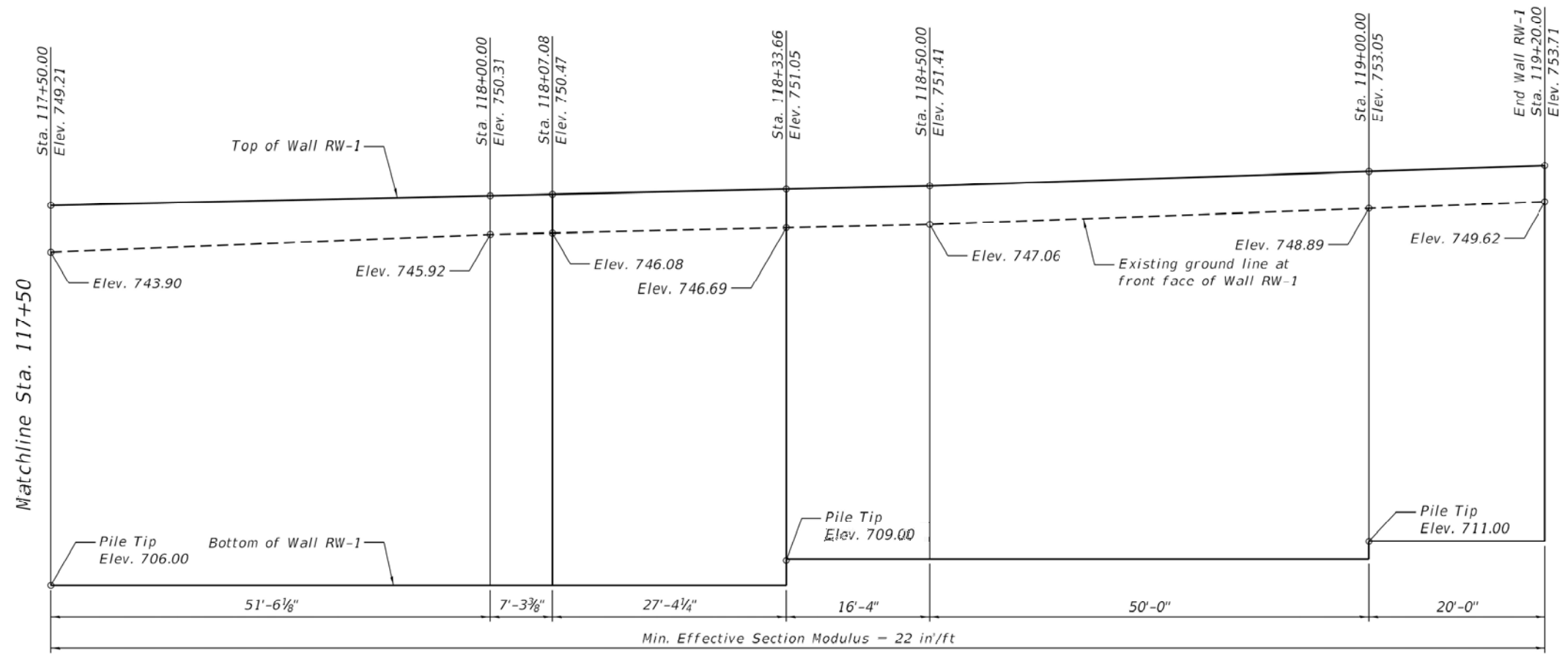

ELEVATION
Back face of wall looking East

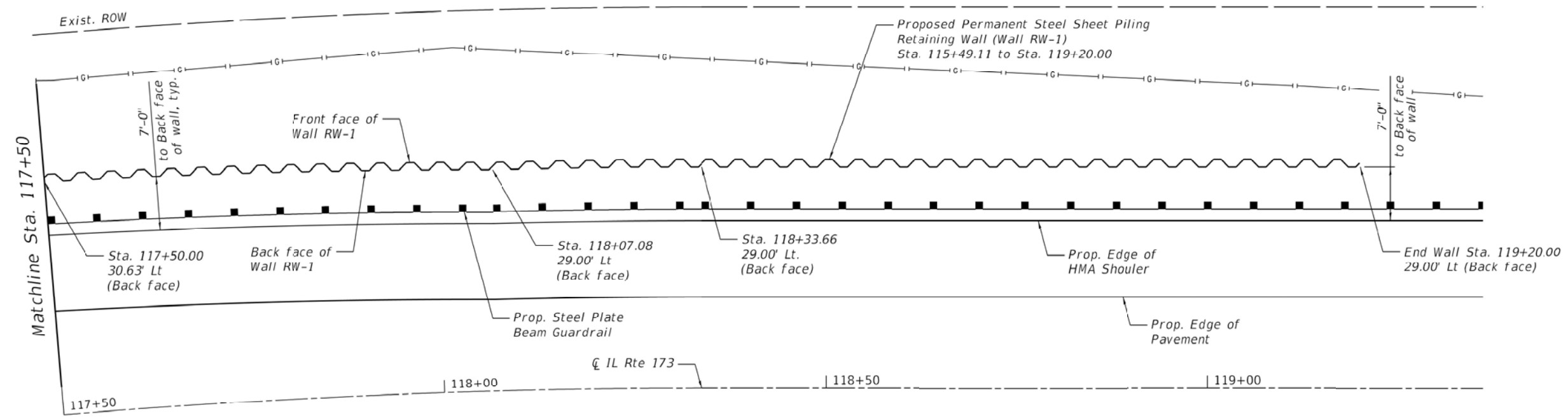

PLAN

MODEL: D:\default
FILE NAME: P:\19-1137.08 IL173-Lake510_IDOT\Structures\1004_RW-1_General Plan & Elevation-2.dgn

Kaskaskia
Engineering Group, LLC
Professional Engineering Firm
11700 S. Main St., Suite 200
Mokena, IL 60451
608.233.2877 phone
608.233.2877 fax
www.kaskaskia.com
11700 S. Main St.
Mokena, IL 60451
90-000004

USER NAME = mcohen	DESIGNED - MLC	REVISED -
PLOT SCALE = N/A	CHECKED - JW	REVISED -
PLOT DATE = 01/22/21	DRAWN - NDP	REVISED -
	CHECKED - JW	REVISED -

STATE OF ILLINOIS
DEPARTMENT OF TRANSPORTATION

IL RTE 173 PERMANENT STEEL SHEET PILE RETAINING WALLS
WALL RW-1 GENERAL PLAN & ELEVATION - 2

F.A.P. RTE. 303	SECTION (134&134X)N	COUNTY LAKE	TOTAL SHEETS 129	SHEET NO. 82
CONTRACT NO. 60V39				
ILLINOIS FED. AID PROJECT				

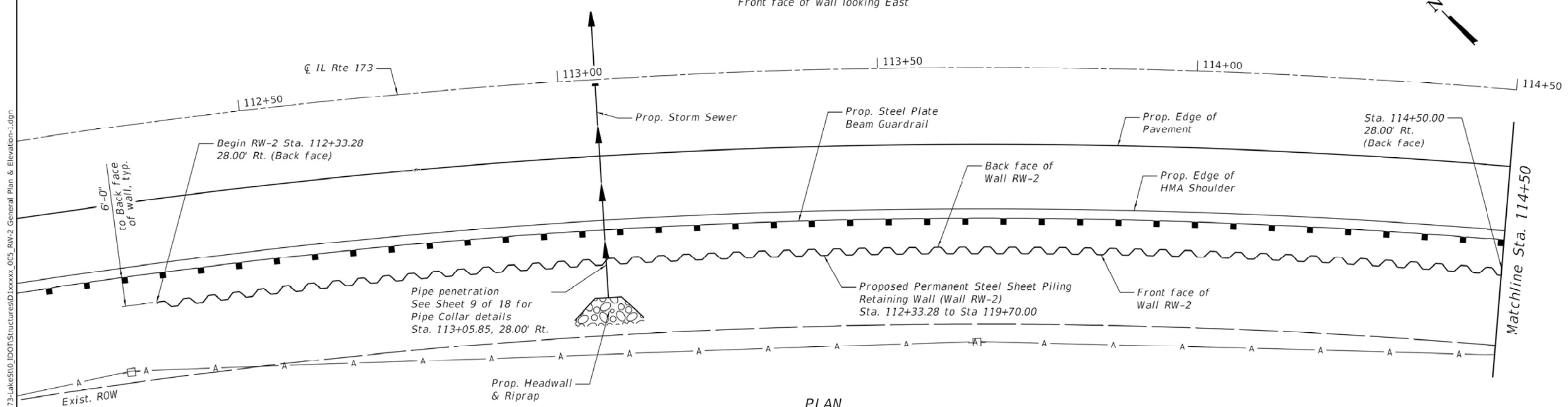
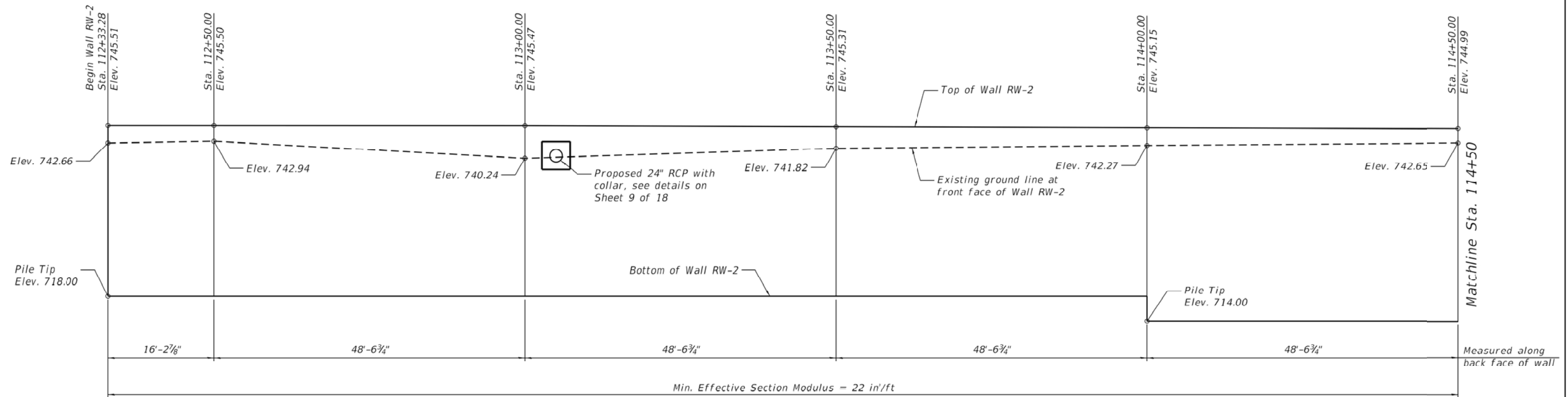

MODEL: D:\faulk FILE NAME: P:\19-1137.08 IL173-Lake510_IDOT\Structures\11370851005_RW-2_General Plan & Elevation-1.dgn

(Sheet 1 of 4)

Kaskaskia
Engineering Group, LLC
Professional Engineering Group

USER NAME = mcohen	DESIGNED - MLC	REVISD -
PLOT SCALE = N/A	CHECKED - JW	REVISD -
PLOT DATE = 01/22/21	DRAWN - NDP	REVISD -
	CHECKED - JW	REVISD -

STATE OF ILLINOIS
DEPARTMENT OF TRANSPORTATION

IL RTE 173 PERMANENT STEEL SHEET PILE RETAINING WALLS
WALL RW-2 GENERAL PLAN & ELEVATION - 1

F.A.P. RTE. 303	SECTION (134&134X)N	COUNTY LAKE	TOTAL SHEETS 129	SHEET NO. 83
CONTRACT NO. 60V39				
ILLINOIS FED. AID PROJECT				

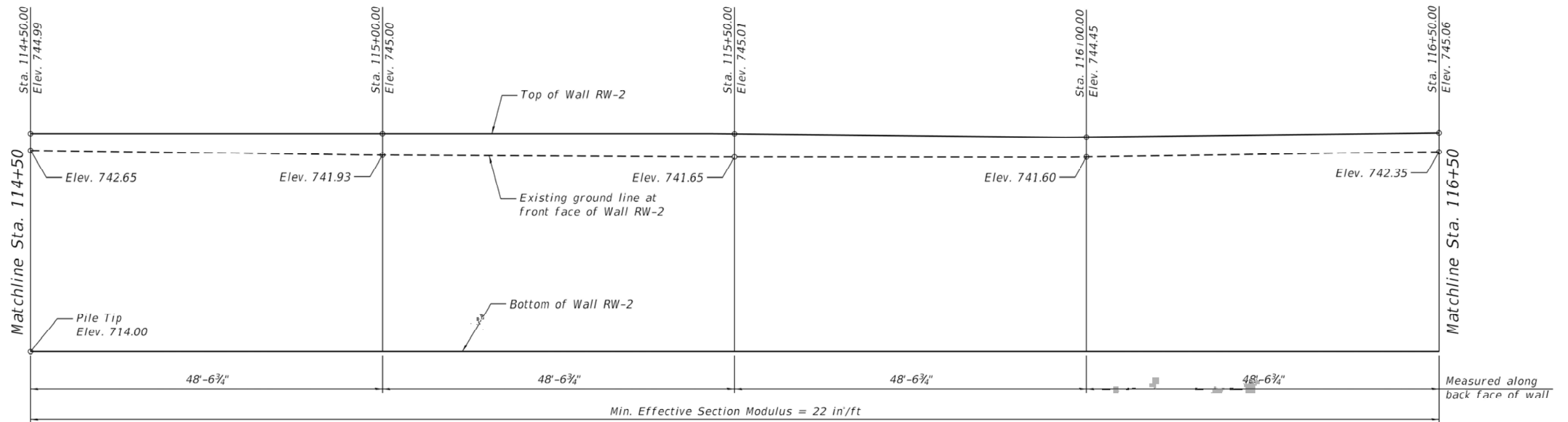

ELEVATION
Front face of wall looking East

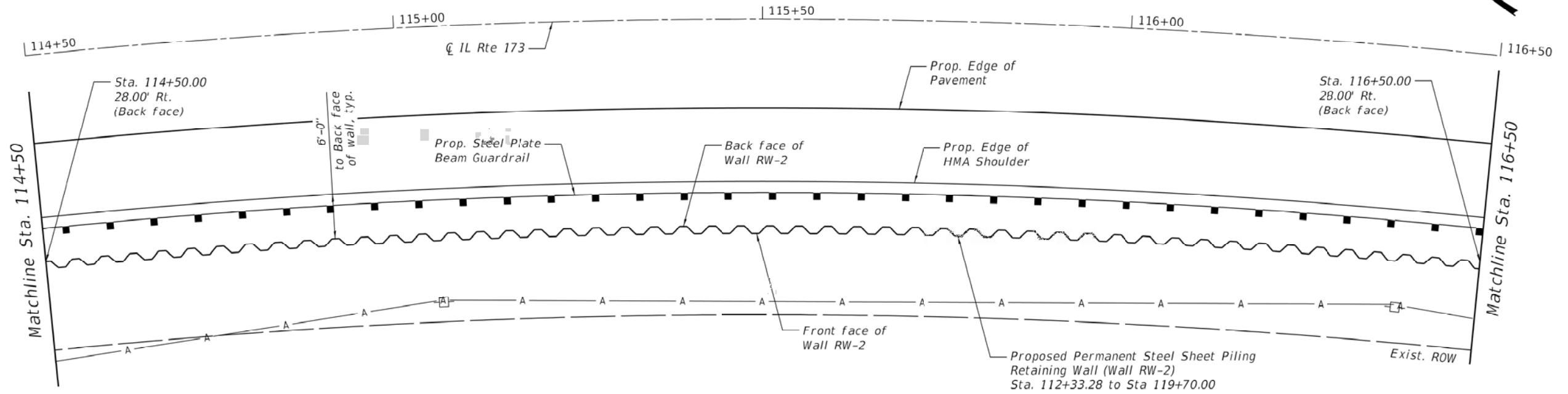

PLAN

(Sheet 2 of 4)

MODEL: D:\default\P\19-1137\08 IL173-Lake510_IDOT\Structures\06_RW-2_General Plan & Elevation-2.dgn

Kaskaskia
Engineering Group, LLC
Professional Engineering Group

USER NAME = mcohen	DESIGNED - MLC	REVISED -
PLOT SCALE = N/A	CHECKED - JW	REVISED -
PLOT DATE = 01/22/21	DRAWN - NDP	REVISED -
	CHECKED - JW	REVISED -

STATE OF ILLINOIS
DEPARTMENT OF TRANSPORTATION

IL RTE 173 PERMANENT STEEL SHEET PILE RETAINING WALLS
WALL RW-2 GENERAL PLAN & ELEVATION - 2

SHEET 6 OF 18 SHEETS

F.A.P. RTE. 303	SECTION (134&134X)N	COUNTY LAKE	TOTAL SHEETS 129	SHEET NO. 84
CONTRACT NO. 60V39				
ILLINOIS FED. AID PROJECT				

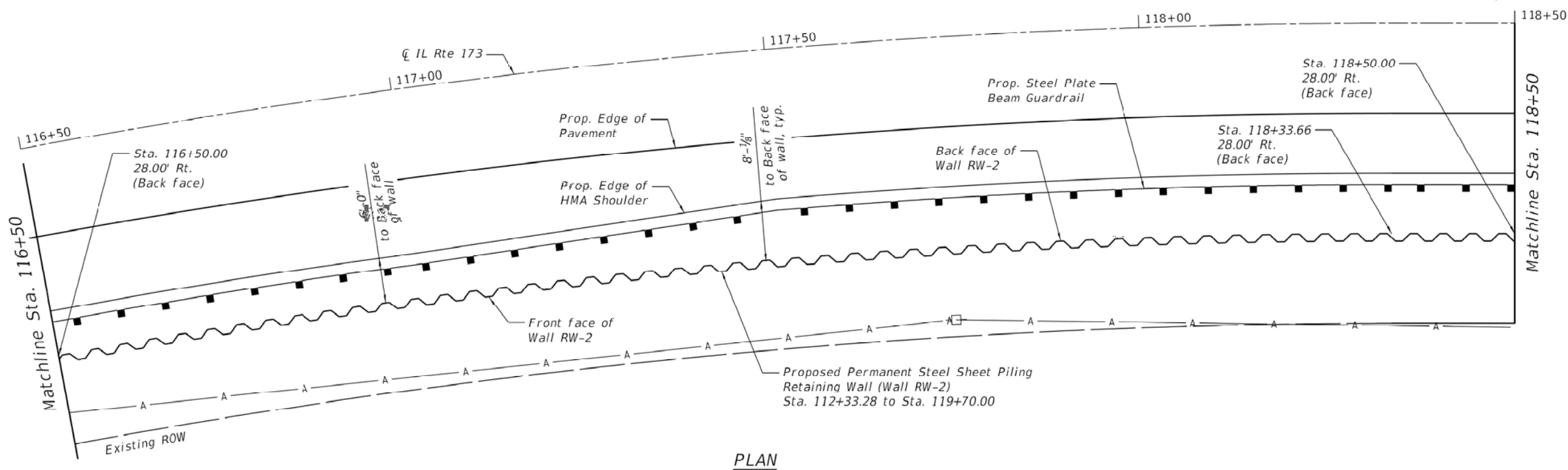
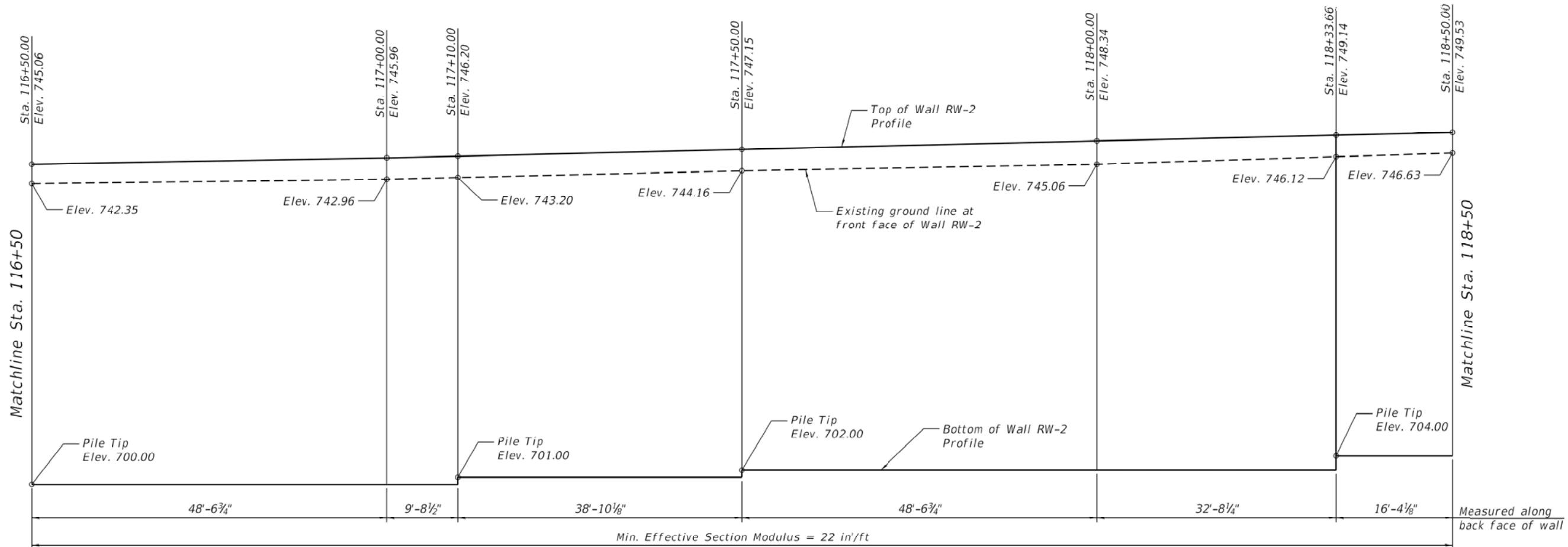

MODEL: D:\faulk
 FILE NAME: P:\19-1137.08 IL173-Lake510_IDOT\Structures\11xxxxx_007_RW-2_General Plan & Elevation-3.dgn

Kaskaskia
 Engineering Group, LLC
 200 E. Main St., Suite 200
 Moline, IL 61401
 309.233.8877
 309.233.8877 Fax
 www.kaskaskiaeng.com
 11/27/2013
 01-000004

USER NAME = mcohen	DESIGNED - MLC	REVISED -
PLOT SCALE = N/A	CHECKED - JW	REVISED -
PLOT DATE = 01/22/21	DRAWN - NDP	REVISED -
	CHECKED - JW	REVISED -

STATE OF ILLINOIS
DEPARTMENT OF TRANSPORTATION

IL RTE 173 PERMANENT STEEL SHEET PILE RETAINING WALLS
WALL RW-2 GENERAL PLAN & ELEVATION - 3

SHEET 7 OF 18 SHEETS

F.A.P. RTE. 303	SECTION (134&134X)N	COUNTY LAKE	TOTAL SHEETS 129	SHEET NO. 85
CONTRACT NO. 60V39				
ILLINOIS FED. AID PROJECT				

(Sheet 3 of 4)

MODEL: Default
 FILE NAME: P:\19-1137.08 IL173-Lake510_IDOT\Structures\1008_RW-2_General Plan & Elevation-4.dgn

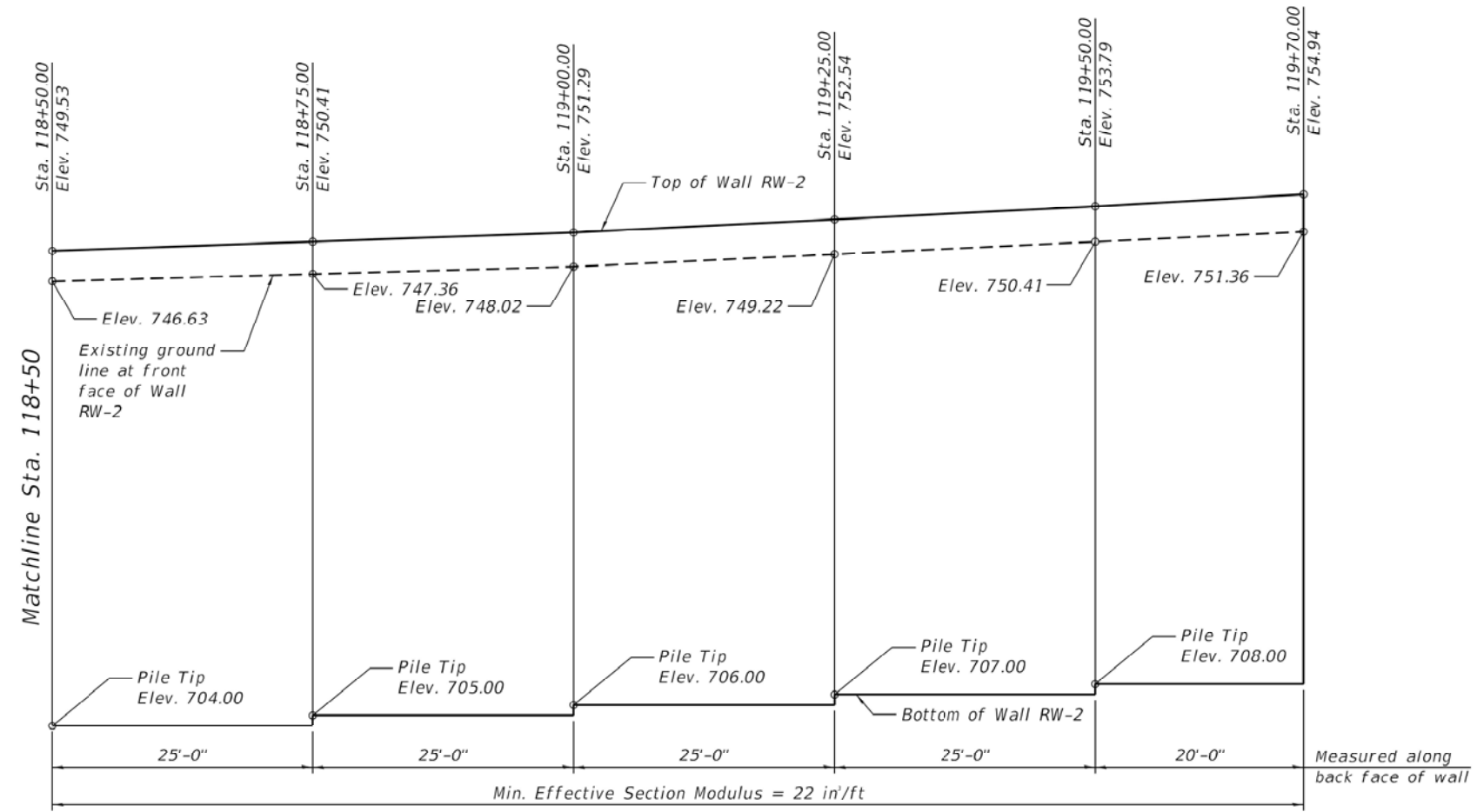

ELEVATION
 Front face of wall looking East

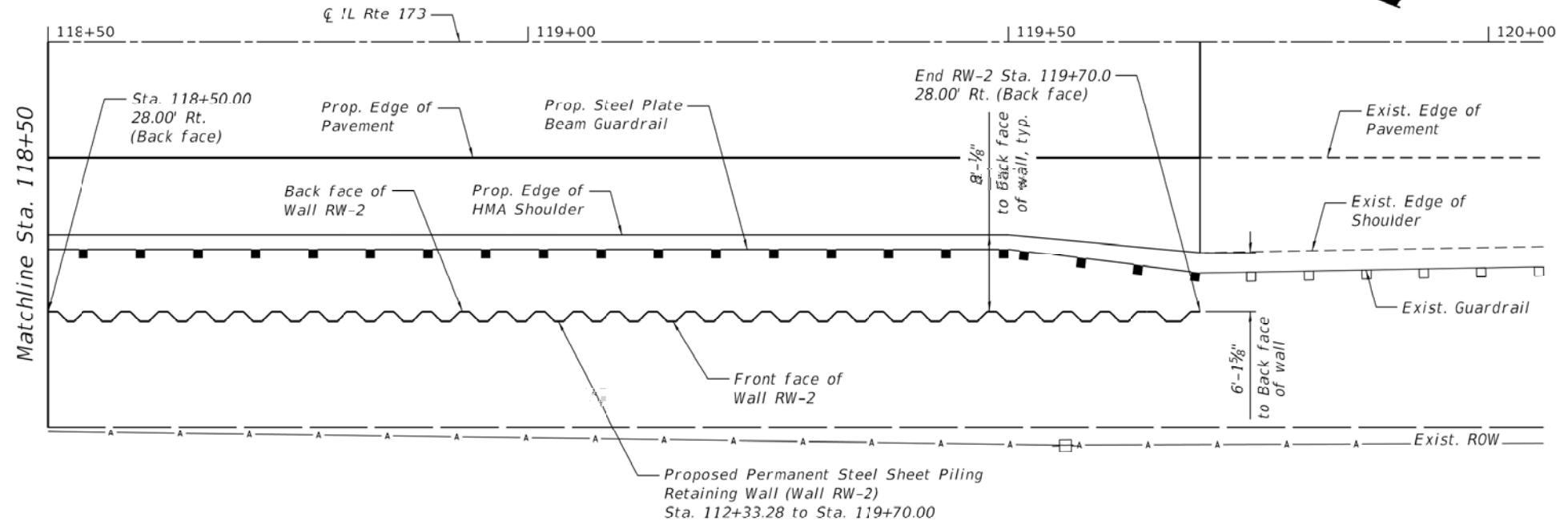
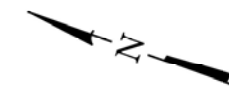

PLAN

(Sheet 4 of 4)



USER NAME = mcohen	DESIGNED - MLC	REVISIONS
PLOT SCALE = N/A	CHECKED - JW	REVISIONS
PLOT DATE = 01/22/21	DRAWN - NDP	REVISIONS
	CHECKED - JW	REVISIONS

STATE OF ILLINOIS
DEPARTMENT OF TRANSPORTATION

IL RTE 173 PERMANENT STEEL SHEET PILE RETAINING WALLS
WALL RW-2 GENERAL PLAN & ELEVATION - 4

SHEET 8 OF 18 SHEETS

F.A.P. RTE.	SECTION	COUNTY	TOTAL SHEETS	SHEET NO.
303	(134&134X)N	LAKE	129	86
CONTRACT NO. 60V39				
ILLINOIS FED. AID PROJECT				

**PIPE COLLAR
BILL OF MATERIAL**

Bar	No.	Size	Length	Shape
a10(E)	12	#5	4'-2"	—
a11(E)	8	#5	3'-2"	—
Reinforcement Bars, Epoxy Coated			Lbs.	80
Concrete Structure			Cu. Yds.	0.9
Stud Shear Connectors			Each	10

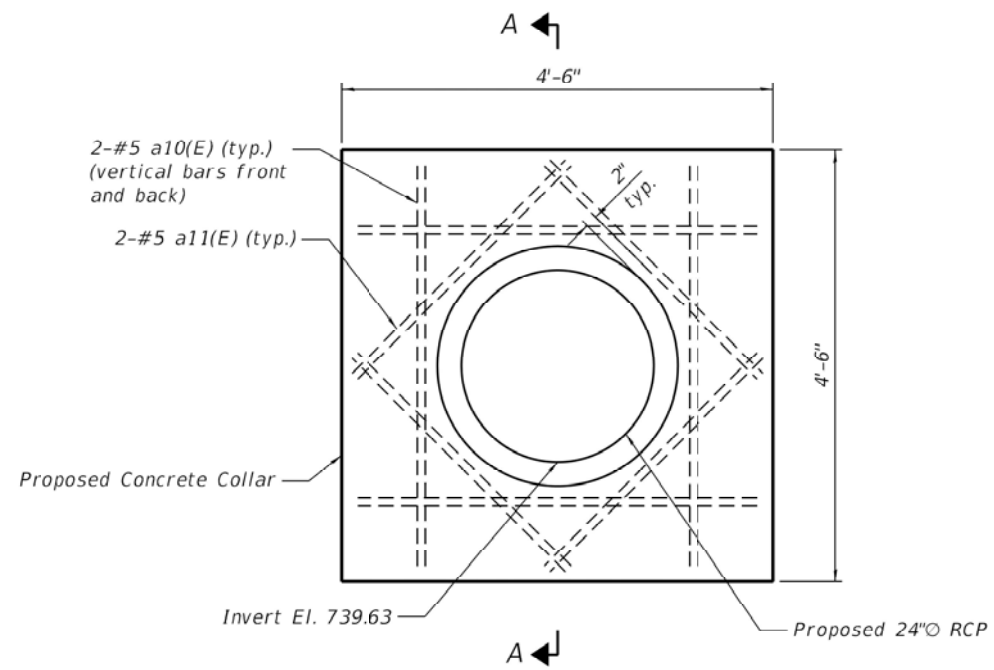

PIPE PENETRATION DETAIL @ STATION 113+05.85 RT

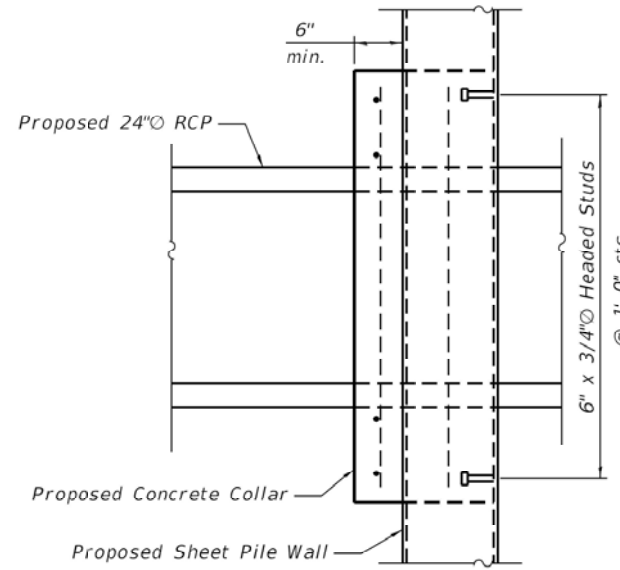

SECTION A-A

MODEL: Default
FILE NAME: P:\19-1137.08 IL173-LakeSt0_IDOT\Structures\01\009_Drainage Pipe Penetration Details.dgn

Kaskaskia
Engineering Group, LLC
Professional Engineering Group

200 E. Main St., Suite 200
Moline, IL 61201
662.233.2877 phone
662.233.2877 fax
www.kaskaskia.com

1/27/2021
11.00011
10.00004

USER NAME = mcohen	DESIGNED - MLC	REVISED -
PLOT SCALE = N/A	CHECKED - JW	REVISED -
PLOT DATE = 01/22/21	DRAWN - NDP	REVISED -
	CHECKED - JW	REVISED -

**STATE OF ILLINOIS
DEPARTMENT OF TRANSPORTATION**

**IL RTE 173 PERMANENT STEEL SHEET PILE RETAINING WALLS
DRAINAGE PIPE PENETRATION DETAILS**

F.A.P. RTE.	SECTION	COUNTY	TOTAL SHEETS	SHEET NO.
303	(134&134X)N	LAKE	129	87
CONTRACT NO. 60V39				
ILLINOIS FED. AID PROJECT				



Himalayan Consultants, LLC
Engineers and Hydrogeologists

Chicago, IL 60601
Phone: (773) 867-2958
Fax: (773) 867-2910

SOIL BORING LOG

Date 9/25/2020

ROUTE FAP 303 (IL 173) DESCRIPTION IL-173 at North Lake Avenue LOGGED BY WL
SECTION S3.T39N.R11E LOCATION IL-173 at North Lake Avenue
COUNTY LAKE COUNTY DRILLING METHOD GEOPROBE HAMMER TYPE GEOPROBE

STRUCT. NO.	DEPT H	BLOW S	UCS Qu	MOIST	Surface Water Elev.	DEPT H	BLOW S	UCS Qu	MOIST
Station	(ft)	(/6")	(tsf)	(%)	ft	(ft)	(/6")	(tsf)	(%)
					Stream Bed Elev.				
BORING NO. <u>WHA-03</u>					Groundwater Elev.:				
Station <u>116+73.15</u>					First Encounter				
Offset <u>42.00 RT</u>					Upon Completion				
Ground Surface Elev. <u>740.12</u> ft					After _____ Hrs.				
Soft, black to gray, PEAT, wet	PUSH	0.25P	61						
	PUSH	0.25P	399						
	PUSH	0.25P	353						
	PUSH	0.25P	302						
	PUSH	0.25P	474						
	PUSH	0.25P	185						
728.12	PUSH	NP	32						
727.12	PUSH	0.25P	70						
724.12	PUSH								
End of Boring									

The Unconfined Compressive Strength (UCS) Failure Mode is indicated by (B-Bulge, S-Shear, P-Penetrometer)
The SPT (N value) is the sum of the last two blow values in each sampling zone (AASHTO T206)

BBS, from 137 (Rev. 8-99)



Himalayan Consultants, LLC
Engineers and Hydrogeologists

Chicago, IL 60601
Phone: (773) 867-2958
Fax: (773) 867-2910

SOIL BORING LOG

Date 9/25/2020

ROUTE FAP 303 (IL 173) DESCRIPTION IL-173 at North Lake Avenue LOGGED BY WL
SECTION S3.T39N.R11E LOCATION IL-173 at North Lake Avenue
COUNTY LAKE COUNTY DRILLING METHOD GEOPROBE HAMMER TYPE GEOPROBE

STRUCT. NO.	DEPT H	BLOW S	UCS Qu	MOIST	Surface Water Elev.	DEPT H	BLOW S	UCS Qu	MOIST
Station	(ft)	(/6")	(tsf)	(%)	ft	(ft)	(/6")	(tsf)	(%)
					Stream Bed Elev.				
BORING NO. <u>WHA-04</u>					Groundwater Elev.:				
Station <u>118+35.98</u>					First Encounter				
Offset <u>47.32 RT</u>					Upon Completion				
Ground Surface Elev. <u>740.46</u> ft					After _____ Hrs.				
Soft, brown to gray, PEAT, trace sand lenses, trace gravel, wet	PUSH	0.25P	66						
	PUSH	0.25P	106						
	PUSH	0.25P	142						
	PUSH	0.25P	562						
	PUSH	0.25P	441						
	PUSH	0.25P	166						
	PUSH	0.25P	458						
	PUSH	0.25P	122						
724.46	PUSH								
End of Boring									

The Unconfined Compressive Strength (UCS) Failure Mode is indicated by (B-Bulge, S-Shear, P-Penetrometer)
The SPT (N value) is the sum of the last two blow values in each sampling zone (AASHTO T206)

BBS, from 137 (Rev. 8-99)

MODEL: D:\default\1137\08_IL173-Lake510_IDOT\Structures\ID1xxxxx_011_Soil Boring_Logs-2.dgn



USER NAME = mcohen
DESIGNED - MLC
CHECKED - JW
PLOT SCALE = N/A
DRAWN - NDP
PLOT DATE = 01/22/21
CHECKED - JW

REVISED -
REVISED -
REVISED -
REVISED -

STATE OF ILLINOIS
DEPARTMENT OF TRANSPORTATION

IL RTE 173 PERMANENT STEEL SHEET PILE RETAINING WALLS
SOIL BORING LOGS - 2
SHEET 11 OF 18 SHEETS

F.A.P. RTE.	SECTION	COUNTY	TOTAL SHEETS	SHEET NO.
303	(134&134X)N	LAKE	129	89
CONTRACT NO. 60V39				
ILLINOIS FED. AID PROJECT				



SOIL BORING LOG

Date 9/24/2020

ROUTE FAP 303 (IL 173) DESCRIPTION IL-173 at North Lake Avenue LOGGED BY WL
SECTION S3.T39N.R11E LOCATION IL-173 at North Lake Avenue
COUNTY LAKE COUNTY DRILLING METHOD GEOPROBE HAMMER TYPE GEOPROBE

STRUCT. NO.	DEPTH	BLOW	UCS	MOIST	Surface Water Elev.	DEPTH	BLOW	UCS	MOIST
Station	(ft)	(/6")	(tsf)	(%)	ft	(ft)	(/6")	(tsf)	(%)
					Stream Bed Elev.				
BORING NO. <u>WHA-05</u>					Groundwater Elev.:				
Station <u>119+16.76</u>					First Encounter	<u>0</u>			
Offset <u>42.50 LT</u>					Upon Completion	<u>N/A</u>			
Ground Surface Elev. <u>740.38</u>					After _____ Hrs.				
Brown to gray, fine to medium grained, SAND, trace gravel, wet		PUSH	NP	9					
		PUSH	NP	3					
		PUSH	NP	6		-25			
		PUSH	NP	12					
		PUSH	NP	13					
		PUSH	NP	19		-30			
		PUSH	NP	16					
		PUSH	NP	17		-35			
End of Boring	724.38								
						-40			

The Unconfined Compressive Strength (UCS) Failure Mode is indicated by (B-Bulge, S-Shear, P-Penetrator)
The SPT (N value) is the sum of the last two blow values in each sampling zone (AASHTO T206)

BBS, from 137 (Rev. 8-99)



SOIL BORING LOG

Date 9/24/2020

ROUTE FAP 303 (IL 173) DESCRIPTION IL-173 at North Lake Avenue LOGGED BY WL
SECTION S3.T39N.R11E LOCATION IL-173 at North Lake Avenue
COUNTY LAKE COUNTY DRILLING METHOD GEOPROBE HAMMER TYPE GEOPROBE

STRUCT. NO.	DEPTH	BLOW	UCS	MOIST	Surface Water Elev.	DEPTH	BLOW	UCS	MOIST
Station	(ft)	(/6")	(tsf)	(%)	ft	(ft)	(/6")	(tsf)	(%)
					Stream Bed Elev.				
BORING NO. <u>WHA-06</u>					Groundwater Elev.:				
Station <u>117+03.00</u>					First Encounter	<u>0</u>			
Offset <u>54.99 LT</u>					Upon Completion	<u>N/A</u>			
Ground Surface Elev. <u>740.26</u>					After _____ Hrs.				
Soft, brown to black, PEAT, trace gravel, wet		PUSH		410					
		PUSH		441					
		PUSH		294		-5			
		PUSH		122					
	732.26								
Very loose, brown to black, SILT, trace gravel, wet		PUSH		28					
		PUSH		70		-10			
	728.26								
Soft, brown to black, PEAT, trace gravel, wet		PUSH		151					
		PUSH		427		-15			
End of Boring	724.26								
						-20			

The Unconfined Compressive Strength (UCS) Failure Mode is indicated by (B-Bulge, S-Shear, P-Penetrator)
The SPT (N value) is the sum of the last two blow values in each sampling zone (AASHTO T206)

BBS, from 137 (Rev. 8-99)

MODEL: D:\default\1137_08_IL173-Lake510_IDOT\Structures\ID1xxxxx_012_Soil Boring_Logs-3.dgn



USER NAME = mcohen	DESIGNED - MLC	REVISED -
PLOT SCALE = N/A	CHECKED - JW	REVISED -
PLOT DATE = 01/22/21	DRAWN - NDP	REVISED -
	CHECKED - JW	REVISED -

STATE OF ILLINOIS
DEPARTMENT OF TRANSPORTATION

IL RTE 173 PERMANENT STEEL SHEET PILE RETAINING WALLS
SOIL BORING LOGS - 3
SHEET 12 OF 18 SHEETS

F.A.P. RTE. 303	SECTION (134&134X)N	COUNTY LAKE	TOTAL SHEETS 129	SHEET NO. 90
CONTRACT NO. 60V39				
ILLINOIS FED. AID PROJECT				

(Sheet 3 of 9)



Himalayan Consultants, LLC
Engineers and Hydrogeologists

Chicago, IL 60601
Phone: (773) 967-2968
Fax: (773) 867-2910

SOIL BORING LOG

Page 1 of 1

Date 9/23/2020

ROUTE FAP 303 (IL 173) DESCRIPTION IL-173 at North Lake Avenue LOGGED BY WL
SECTION S3.T39N.R11E LOCATION IL-173 at North Lake Avenue
COUNTY LAKE COUNTY DRILLING METHOD GEOPROBE HAMMER TYPE GEOPROBE

STRUCT. NO.	DEPTH	BLOW	UCS	MOIST	Surface Water Elev.	DEPTH	BLOW	UCS	MOIST
Station	(ft)	(/6")	(tsf)	(%)	ft	(ft)	(/6")	(tsf)	(%)
BORING NO. <u>WHA-07</u>					Groundwater Elev.:				
Station <u>115+79.55</u>					First Encounter				
Offset <u>48.18 LT</u>					Upon Completion				
Ground Surface Elev. <u>738.78</u> ft					After				
					Hrs.				
Soft to medium stiff, black to gray, PEAT, wet		PUSH	0.25P	119					
		PUSH	0.25P	333					
		PUSH	0.25P	350					
		PUSH	0.25P	421					
		PUSH	0.25P	238					
		PUSH	0.50P	346					
		PUSH	0.25P	204					
		PUSH	0.25P	183					
End of Boring	722.78								

The Unconfined Compressive Strength (UCS) Failure Mode is indicated by (B-Bulge, S-Shear, P-Penetrometer)
The SPT (N value) is the sum of the last two blow values in each sampling zone (AASHTO T206)

BBS, from 137 (Rev. 8-99)



Himalayan Consultants, LLC
Engineers and Hydrogeologists

Chicago, IL 60601
Phone: (773) 967-2968
Fax: (773) 867-2910

SOIL BORING LOG

Page 1 of 1

Date 9/19/2020

ROUTE FAP 303 (IL 173) DESCRIPTION IL-173 at North Lake Avenue LOGGED BY WL
SECTION S3.T39N.R11E LOCATION IL-173 at North Lake Avenue
COUNTY LAKE COUNTY DRILLING METHOD HSA to 30' HAMMER TYPE CME 55 (85%)

STRUCT. NO.	DEPTH	BLOW	UCS	MOIST	Surface Water Elev.	DEPTH	BLOW	UCS	MOIST
Station	(ft)	(/6")	(tsf)	(%)	ft	(ft)	(/6")	(tsf)	(%)
BORING NO. <u>WRB-01</u>					Groundwater Elev.:				
Station <u>112+22.02</u>					First Encounter				
Offset <u>16.23 RT</u>					Upon Completion				
Ground Surface Elev. <u>745.70</u> ft					After				
					Hrs.				
11 1/2" Asphalt									
3" Aggregate Base Coarse	744.74								
Medium dense, black, GRAVELLY LOAM, dry FILL	744.49	11	NP	7					
		7							
		4	NP	13					
		6							
		8							
		8							
	741.70	3	NP	3					
Loose to medium dense, brown, fine to medium grained, SAND, trace silt lenses, dry to wet		5							
		3							
		3	NP	19					
		3							
		3							
		3	NP	22					
		2							
		2							
		2							
		2	NP	24					
		1							
		2							
		2							
		2							
		2	NP	28					
		1							
		3							
		4							
		1	NP	17					
		2							
		2							
		2							
		2	NP	15					
		3							
		4							
		2							
		3							
		3	NP	19					
		3							
		3							
End of Boring	715.70								

The Unconfined Compressive Strength (UCS) Failure Mode is indicated by (B-Bulge, S-Shear, P-Penetrometer)
The SPT (N value) is the sum of the last two blow values in each sampling zone (AASHTO T206)

BBS, from 137 (Rev. 8-99)

MODEL: Default
FILE NAME: P:\19-1137\08 IL173-LakeSt0_IDOT\Structures\1137_013_Soil Boring Logs-4.dgn



USER NAME = mcohen	DESIGNED - MLC	REVISED -
PLOT SCALE = N/A	CHECKED - JW	REVISED -
PLOT DATE = 01/22/21	DRAWN - NDP	REVISED -
	CHECKED - JW	REVISED -

STATE OF ILLINOIS
DEPARTMENT OF TRANSPORTATION

IL RTE 173 PERMANENT STEEL SHEET PILE RETAINING WALLS
SOIL BORING LOGS - 4

SHEET 13 OF 18 SHEETS

F.A.P. RTE.	SECTION	COUNTY	TOTAL SHEETS	SHEET NO.
303	(134&134X)N	LAKE	129	91
CONTRACT NO. 60V39				
ILLINOIS FED. AID PROJECT				

(Sheet 4 of 9)



SOIL BORING LOG

Date 9/19/2020

ROUTE FAP 303 (IL 173) DESCRIPTION IL-173 at North Lake Avenue LOGGED BY WL
 SECTION S3.T39N.R11E LOCATION IL-173 at North Lake Avenue
 COUNTY LAKE COUNTY DRILLING METHOD HSA to 30' HAMMER TYPE CME 55 (85%)

STRUCT. NO.	Station	DEPTH (ft)	BLOW (blows/ft)	UCS (tsf)	MOISTURE (%)	DESCRIPTION	DEPTH (ft)	BLOW (blows/ft)	UCS (tsf)	MOISTURE (%)
		753.65				8" Asphalt				
		753.15	14	NP	4	6" Aggregate Base Coarse		1	0	43
			25			Loose to dense, black to brown, GRAVEL, trace loam lenses, dry FILL		1		
			7					2		
			5			organic silt lens at 21 to 22				
		750.32	3	NP				1	NP	24
			3			Soft to stiff, brown, SANDY CLAY LOAM, trace gravel, dry to wet		1		
			2	1.75P	12			2		
			3					2		
			3					2		
			3					2		
			8	0.74B	10	organic silt lens at 26 to 27		2	0	34
			3					2		
			3					2		
			4	0.74B	4			4	0.25P	31
			2					7		
			2					8		
			1			End of Boring	724.32	-30		
			2	0.90B	9					
			1							
			2							
			1	0.57B	16					
			2							
			3							
			1							
			2	0.25P	14					
			3							
			3							
		735.82	1	NP	19	Very loose medium dense, brown, fine to medium grained, SANDY LOAM, trace gravel, wet				
			2							
			1							

The Unconfined Compressive Strength (UCS) Failure Mode is indicated by (B-Bulge, S-Shear, P-Penetrometer)
 The SPT (N value) is the sum of the last two blow values in each sampling zone (AASHTO T206)
 BBS, from 137 (Rev. 8-99)



SOIL BORING LOG

Date 9/22/2020

ROUTE FAP 303 (IL 173) DESCRIPTION IL-173 at North Lake Avenue LOGGED BY WL
 SECTION S3.T39N.R11E LOCATION IL-173 at North Lake Avenue
 COUNTY LAKE COUNTY DRILLING METHOD HSA to 10'; Mud Rotary after 10' HAMMER TYPE CME 55 (85%)

STRUCT. NO.	Station	DEPTH (ft)	BLOW (blows/ft)	UCS (tsf)	MOISTURE (%)	DESCRIPTION	DEPTH (ft)	BLOW (blows/ft)	UCS (tsf)	MOISTURE (%)
						12" Asphalt				
		745.37								
		745.07	6	NP	7	3.5" Aggregate Base Coarse				
			7			Very loose to medium dense, brown, fine to medium grained, SANDY LOAM, trace clay, trace gravel, little silt lenses, some peat lenses, dry to wet		1		
			5					1		
			3					3		
		723.37	3	NP	6	Loose, brown, fine to medium grained, SAND, trace gravel		5	NP	11
			3					4		
			2					4		
			2					5		
			3					5		
			4	NP	4			4		
			4			Soft to stiff, brown to gray, SANDY CLAY LOAM, wet		3	0.25P	79
		720.37	4			trace organics 26 to 26.5		2		
			2					2		
			2					1	1.07B	29
			1					1		
			4	NP	6			3		
			3					3		
			1					1		
			4	NP	18			4		
			1					1		
			2	NP	16			4	0.5B	27
			3					3		
			4					5		
		711.37	5	NP	14	Medium to dense, gray, SANDY LOAM, wet				
			4							
			3							
			2	NP	20			10	NP	23
			1					8		
			2					14		

The Unconfined Compressive Strength (UCS) Failure Mode is indicated by (B-Bulge, S-Shear, P-Penetrometer)
 The SPT (N value) is the sum of the last two blow values in each sampling zone (AASHTO T206)
 BBS, from 137 (Rev. 8-99)

(Log WRB-04 Pg. 1 of 2)

(Sheet 6 of 9)

MODEL: D:\default\1137.08 IL173-Lake510_IDOT\Structures\1137.08_IL173_Soil Boring_Logs-6.dgn



USER NAME = mcohen	DESIGNED - MLC	REVISED -
PLOT SCALE = N/A	CHECKED - JW	REVISED -
PLOT DATE = 01/22/21	DRAWN - NDP	REVISED -
	CHECKED - JW	REVISED -

STATE OF ILLINOIS
 DEPARTMENT OF TRANSPORTATION

IL RTE 173 PERMANENT STEEL SHEET PILE RETAINING WALLS
 SOIL BORING LOGS - 6
 SHEET 15 OF 18 SHEETS

F.A.P. RTE. 303	SECTION (134&134X)N	COUNTY LAKE	TOTAL SHEETS 129	SHEET NO. 93
CONTRACT NO. 60V39				
ILLINOIS FED. AID PROJECT				



SOIL BORING LOG

Page 1 of 1

Date 4/25/13

ROUTE IL-173 DESCRIPTION at North Lake Avenue LOGGED BY M. Esposito
 SECTION (134&134X)N LOCATION SEC. TWP. 46N, RNG. 9E, 3rd PM
 COUNTY Lake DRILLING METHOD Mobile, B80, 3.85" HSA HAMMER TYPE _____

STRUCT. NO. Station	DEPTH H	BLOW S	UCS Qu	MOIST T	Surface Water Elev. _____ ft Stream Bed Elev. _____ ft
BORING NO. <u>RB-6</u> Station <u>115+83</u> Offset <u>17.00ft LT</u> Ground Surface Elev. <u>746.87</u> ft	(ft)	(/6")	(tsf)	(%)	Groundwater Elev.: First Encounter <u>739.9</u> ft ▼ Upon Completion <u>cave in</u> ft After _____ Hrs. _____ ft
Hot-Mix Asphalt					
	745.37		3		
Gray Gravel			3		
	743.87		9		
Brown Coarse Sand			5		
	-5		10		
			10		
			16		
			15		
	-10				
Note: No recovery in sampler past 10 feet (very wet sand)					
	731.87				
Note: Qu Data Obtained By Pocket Penetrometer End of Boring					
	-15				
	-20				

The Unconfined Compressive Strength (UCS) Failure Mode is indicated by (B-Bulge, S-Shear, P-Penetrometer)
 The SPT (N value) is the sum of the last two blow values in each sampling zone (AASHTO T206)
 BBS, from 137 (Rev. 8-99)



SOIL BORING LOG

Page 1 of 1

Date 4/25/13

ROUTE IL-173 DESCRIPTION at North Lake Avenue LOGGED BY M. Esposito
 SECTION N/A LOCATION SEC. TWP. 46N, RNG. 9E, 3rd PM
 COUNTY Lake DRILLING METHOD Mobile, B80, 3.85" HSA HAMMER TYPE _____

STRUCT. NO. Station	DEPTH H	BLOW S	UCS Qu	MOIST T	Surface Water Elev. _____ ft Stream Bed Elev. _____ ft
BORING NO. <u>RB-7</u> Station <u>118+59</u> Offset <u>17.00ft LT</u> Ground Surface Elev. <u>752.93</u> ft	(ft)	(/6")	(tsf)	(%)	Groundwater Elev.: First Encounter _____ ft Upon Completion _____ ft After _____ Hrs. _____ ft
Hot-Mix Asphalt Pavement					
	751.43		6		
Brown Coarse Sand			5		
			5		
	-5		4		
			7		
			5		
			5		
			6		
	742.93				
Note: Qu Data Obtained By Pocket Penetrometer End of Boring					
	-15				
	-20				

The Unconfined Compressive Strength (UCS) Failure Mode is indicated by (B-Bulge, S-Shear, P-Penetrometer)
 The SPT (N value) is the sum of the last two blow values in each sampling zone (AASHTO T206)
 BBS, from 137 (Rev. 8-99)

MODEL: Default
 FILE NAME: P:\19-1137\08_IL173-Lake510_IDOT\Structures\1xxxxx_018_Soil Boring Logs-9.dgn



USER NAME = mcohen	DESIGNED - MLC	REVISED -
PLOT SCALE = N/A	CHECKED - JW	REVISED -
PLOT DATE = 01/22/21	DRAWN - NDP	REVISED -
	CHECKED - JW	REVISED -

STATE OF ILLINOIS
 DEPARTMENT OF TRANSPORTATION

IL RTE 173 PERMANENT STEEL SHEET PILE RETAINING WALLS
 SOIL BORING LOGS - 9

F.A.P. RTE.	SECTION	COUNTY	TOTAL SHEETS	SHEET NO.
303	(134&134X)N	LAKE	129	96
CONTRACT NO. 60V39			ILLINOIS FED. AID PROJECT	

(Sheet 9 of 9)

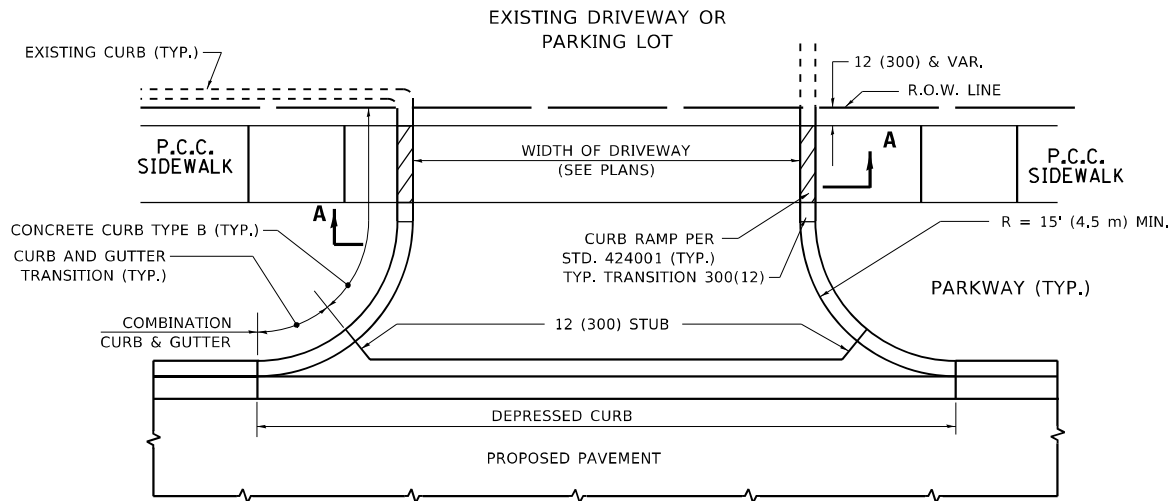

WITH CONCRETE CURB, TYPE B

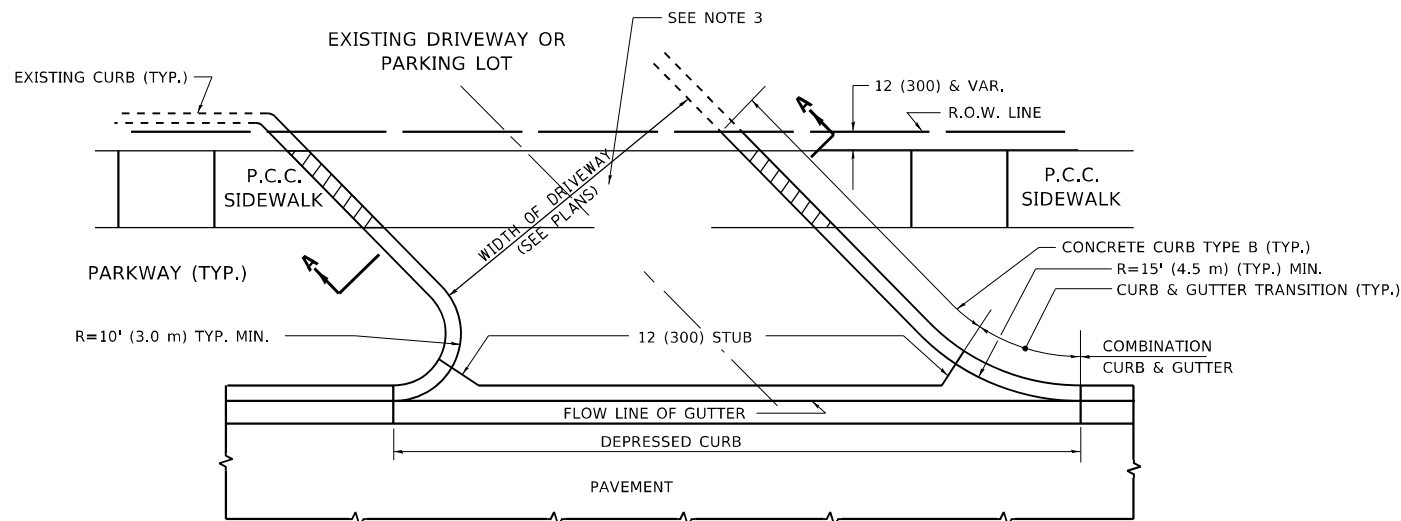

WITH CONCRETE CURB, TYPE B

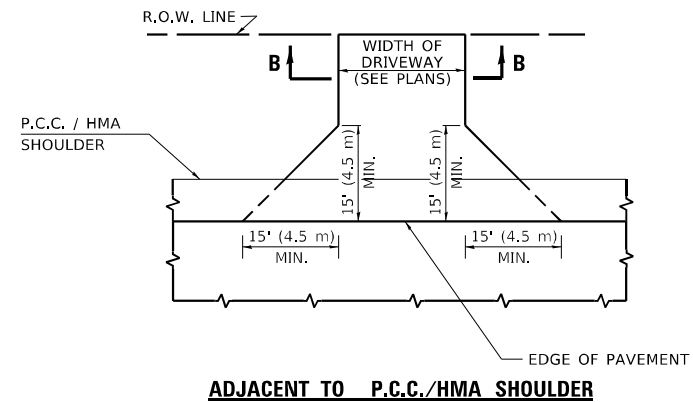

ADJACENT TO P.C.C./HMA SHOULDER

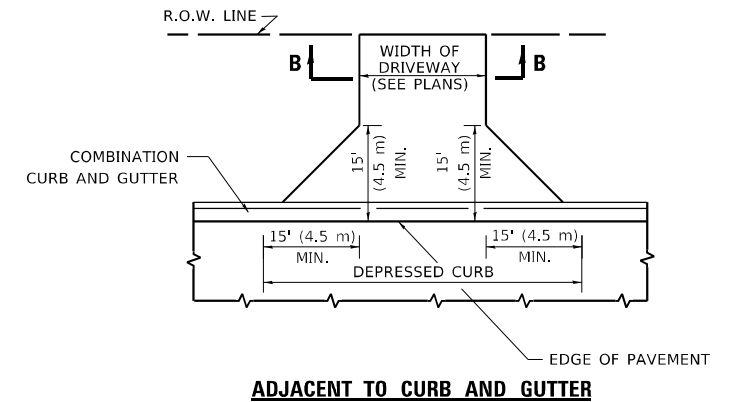

ADJACENT TO CURB AND GUTTER

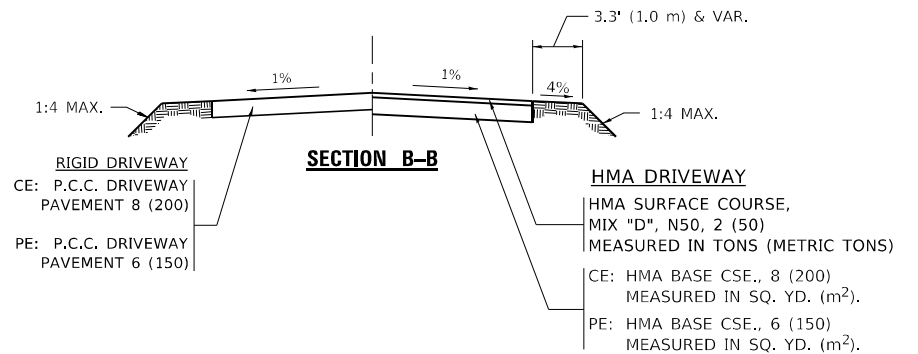

GENERAL NOTES:

DRIVEWAY SLOPES, LOCATIONS, & GEOMETRIC LAYOUT SHALL BE IN ACCORDANCE WITH THE LATEST EDITION OF THE "HANDBOOK FOR POLICY ON PERMITS FOR ACCESS DRIVEWAYS TO STATE HIGHWAYS". FOR FURTHER LAYOUT REQUIREMENTS, REFER TO ILLUSTRATIONS IN THE PERMIT HANDBOOK. DRIVEWAYS SHALL BE REPLACED IN KIND, UNLESS OTHERWISE NOTED ON THE PLANS.

COMMERCIAL DRIVEWAYS SHALL BE CONSTRUCTED WITH CONCRETE CURB, TYPE B RETURNS EXCEPT WHEN THE SIDEWALK EDGE IS 4 FEET (1.2 METERS) OR LESS FROM THE BACK OF CURB, CONSTRUCT A FLARE DRIVEWAY WITHOUT CURB.

THE RESIDENT ENGINEER SHALL CONTACT THE TRAFFIC PERMIT OFFICE AT 847/ 705-4131 FOR ANY QUESTIONS ON DRIVEWAYS SHOWN IN THE PLANS; SPECIFICALLY IN REFERENCE TO ADDITIONAL AND/OR RELOCATION/REMOVAL OF A DRIVEWAY.

COMBINATION CONCRETE CURB & GUTTER SHALL BE MEASURED STRAIGHT ACROSS THE DRIVEWAY. NO ADDITIONAL COMPENSATION WILL BE ALLOWED FOR THE CURB & GUTTER TRANSITION.

1 (25) PREFORMED EXPANSION JOINT FILLER WILL NOT BE PAID SEPARATELY, BUT SHALL BE CONSIDERED INCLUDED IN THE COST OF THE P.C.C. DRIVEWAY PAVEMENT OR P.C.C. SIDEWALK.

WHEN THE P.C.C. SIDEWALK EXTENDS THROUGH THE DRIVEWAY, THE THICKNESS OF THE SIDEWALK IN THE DRIVEWAY AREA SHALL BE THE SAME AS THE DRIVEWAY THICKNESS. SIDEWALK WILL BE PAID FOR AS P.C.C. SIDEWALK OF THE THICKNESS SPECIFIED. SIDEWALK CROSS SLOPE THRU DRIVEWAY AREA TO BE A MAXIMUM OF 1:50.

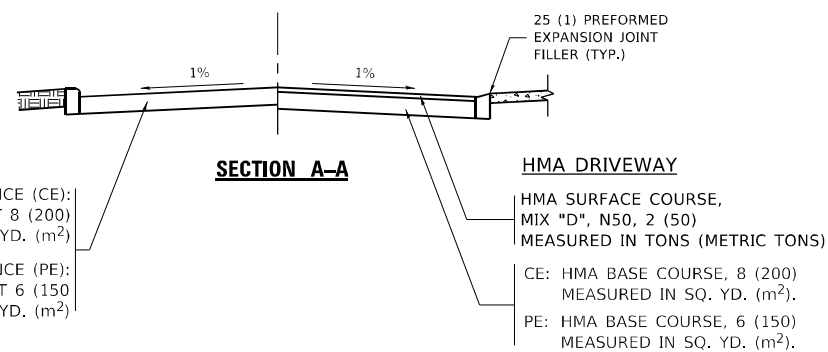

RIGID DRIVEWAY

COMMERCIAL ENTRANCE (CE):
P.C.C. DRIVEWAY PAVEMENT 8 (200)
MEASURED IN SQ. YD. (m²)

NON-COMMERCIAL ENTRANCE (PE):
P.C.C. DRIVEWAY PAVEMENT 6 (150)
MEASURED IN SQ. YD. (m²)

SECTION A-A

HMA DRIVEWAY

HMA SURFACE COURSE,
MIX "D", N50, 2 (50)
MEASURED IN TONS (METRIC TONS)

CE: HMA BASE COURSE, 8 (200)
MEASURED IN SQ. YD. (m²).
PE: HMA BASE COURSE, 6 (150)
MEASURED IN SQ. YD. (m²).

**STATE OF ILLINOIS
DEPARTMENT OF TRANSPORTATION**

**DRIVEWAY DETAILS – DISTANCE BETWEEN R.O.W.
AND FACE OF CURB & EDGE OF SHOULDER ≥ 15'(4.5m)**
SCALE: NONE SHEET 1 OF 1 SHEETS STA. TO STA.

F.A.P. RTE.	SECTION	COUNTY	TOTAL SHEETS	SHEET NO.
303	(134&134XIN	LAKE	129	97
BD400-01 (BD-01)		CONTRACT NO. 60V39		
ILLINOIS FED. AID PROJECT				

MODEL: Default
FILE NAME: p:\data\m3000\dot\illinois\pwr\p\dot\Documents\DOT - Office\Drawings - 1\Project\171099\CADD\data\Design\DrivStk.dgn

USER NAME = kalorm	DESIGNED - R. SHAH	REVISED - P. LoFLUER 04-15-03
PLOT SCALE = 100,0002' / in.	DRAWN -	REVISED - R. BORO 01-01-07
PLOT DATE = 1/27/2021	CHECKED -	REVISED - R. BORO 06-11-08
	DATE - 11-04-95	REVISED - R. BORO 09-06-11

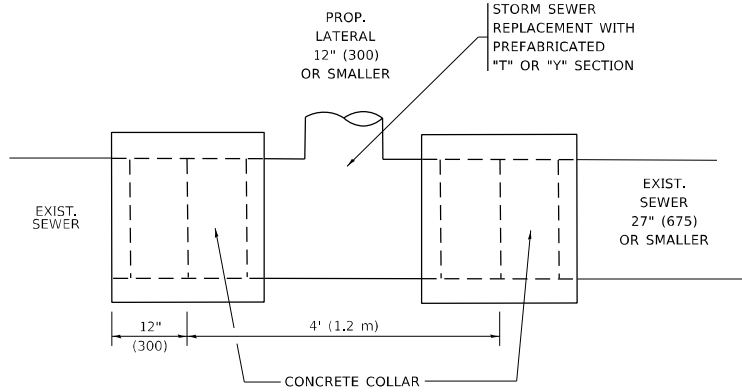

DETAIL "A"

LATERAL CONNECTION TO EXISTING SEWER OF 27" (675) OR SMALLER

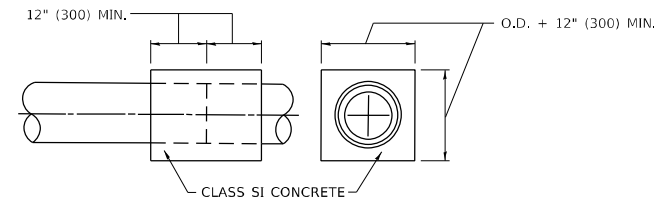
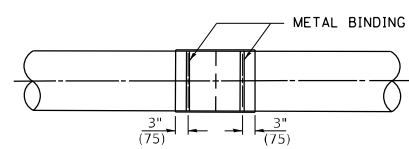
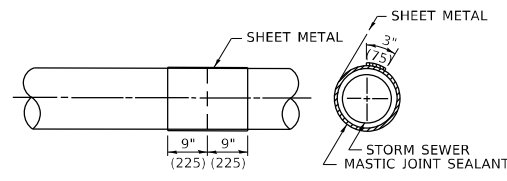
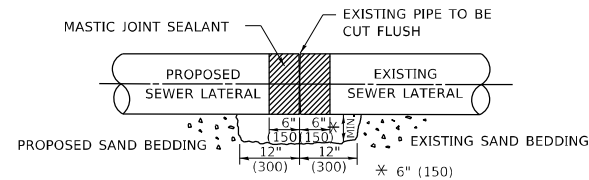

DETAIL "B"

CLASS SI CONCRETE COLLAR

CONSTRUCTION SEQUENCE

1. CUT THE EXISTING END OF THE PIPE SO AS TO PRESENT A FLUSH BUTT JOINT, BRUSH AND CLEAN ALL PIPES.
2. APPLY THE MASTIC JOINT SEALANT TO THE FIRST 6" (150) OF EACH PIPE.
3. BUTT THE PIPES TOGETHER LEAVING A MINIMUM OF 12' x 6' (300 x 150) DEEP EXCAVATION UNDER AND AROUND EACH PIPE END.
4. CUT A PIECE OF SHEET METAL GAGE NO. 19 1.1 (0.0418) 18" (450) WIDE BY THE OUTSIDE CIRCUMFERENCE OF THE PIPE PLUS 3" (75) LONG.
5. WRAP THE SHEET METAL AROUND THE PIPES, 9" (225) ON EACH SIDE OF THE JOINT, STARTING AT THE TOP OF THE PIPE.
6. LAP THE SHEET METAL AT LEAST 3" (75) AT THE TOP OF THE PIPE AND PLACE THE MASTIC JOINT SEALANT BETWEEN THE LAP.
7. PLACE TWO METAL BANDS AROUND THE SHEET METAL AND TIGHTEN.
8. WIPE OFF ANY EXCESS MASTIC JOINT SEALANT THAT OOZES OUT FROM BETWEEN THE SHEET METAL AND THE PIPES.
9. PLACE CLASS SI CONCRETE AROUND THE JOINT.

* ALL DIMENSIONS ARE IN INCHES (MILLIMETERS) UNLESS OTHERWISE SHOWN.

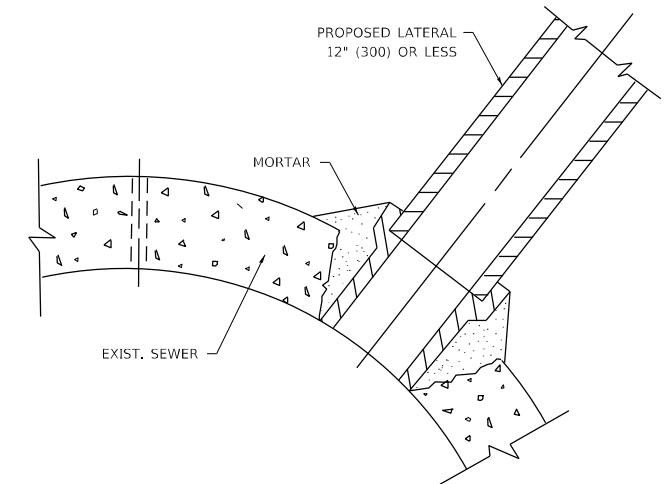

DETAIL "C"

PROPOSED LATERAL CONNECTION TO EXISTING SEWER OF 30" (750) OR LARGER

NOTES:

MATERIAL

MATERIAL USED FOR THE TEE OR WYE SECTION SHALL BE COMPATIBLE WITH THE EXISTING STORM SEWER OR THE PROPOSED STORM SEWER.

CONSTRUCTION METHODS

- THIS WORK SHALL BE CONSTRUCTED IN CONFORMANCE WITH THE APPLICABLE PORTIONS OF SECTION 550 OF THE STANDARD SPECIFICATIONS.
- CONNECTION TO AN EXISTING STORM SEWER SHALL BE BY EITHER OF THE FOLLOWING METHODS:
 - PROPOSED STORM SEWER CONNECTION TO EXISTING SEWER OF 27" (675) OR SMALLER SEE DETAIL "A" AND "B".
 - PROPOSED STORM SEWER CONNECTION TO EXISTING SEWER OF 30" (750) OR LARGER SEE DETAIL "C".

IF THE EXISTING SEWER PIPE IS CRACKED, BROKEN OR OTHERWISE DAMAGED BY THE CONTRACTOR IN MAKING THE CIRCULAR OPENING, THE CONTRACTOR SHALL REPLACE THAT SECTION OF PIPE WITH PIPE EQUAL AND SIMILAR IN ALL RESPECTS TO THE PIPE IN THE EXISTING SEWER, IN A CAREFUL WORKMANLIKE MANNER, WITHOUT EXTRA COMPENSATION.

GENERAL

CARE MUST BE TAKEN TO PREVENT DEBRIS FROM ENTERING THE SEWER. ALL DEBRIS WHICH ENTERS THE SEWER MUST BE REMOVED. THE SEWER MUST BE LEFT CLEAN AND UNOBSTRUCTED UPON COMPLETION OF THE CONTRACT.

CARE MUST BE TAKEN TO PREVENT ANY PART OF THE NEW PIPE CONNECTION FROM PROJECTING INTO THE EXISTING SEWER.

BASIS OF PAYMENT

TEE OR WYE CONNECTIONS SHALL BE PAID FOR AT THE CONTRACT UNIT PRICE EACH FOR STORM SEWER TEE OR WYE OF THE TYPE AND SIZE SPECIFIED IN THE PLANS, THIS PRICE SHALL INCLUDE ALL EXCAVATION OF THE TRENCH, REMOVAL OF THE EXISTING STORM SEWER, FURNISHING AND INSTALLING THE SPECIFIED TEE OR WYE SECTION, FURNISHING AND INSTALLING THE REQUIRED CONCRETE COLLAR, AND ALL OTHER MATERIAL NECESSARY TO COMPLETE THIS WORK AS SHOWN AND SPECIFIED.

REMOVAL AND REINSTALLATION OF EXISTING STORM SEWER ADJACENT TO THE PROPOSED TEE OR WYE SECTION, FOR THE PURPOSE OF FACILITATING THE INSTALLATION OF THE TEE OR WYE SECTION, WILL NOT BE PAID FOR SEPARATELY BUT SHALL BE INCLUDED IN THE UNIT PRICE BID FOR THE WORK.

TRENCH BACKFILL, EXCAVATION IN ROCK AND REMOVAL AND REPLACEMENT OF UNSUITABLE MATERIAL BELOW PLAN BEDDING GRADE WILL BE PAID FOR SEPARATELY.

CONCRETE COLLAR FOR CONNECTING A PROPOSED STORM SEWER TO AN EXISTING STORM SEWER WILL NOT BE PAID FOR SEPARATELY BUT SHALL BE INCLUDED IN THE COST OF THE PROPOSED STORM SEWER.

MODEL: Default
FILE NAME: p:\mhammond.dwg
PROJECT: P1710909\CADD\DATA\Design\DRS\StS.dgn

USER NAME = kalm	DESIGNED - M. DE YONG	REVISED - M. DE YONG 5-8-92
	DRAWN -	REVISED - R. SHAH 09-09-94
PLOT SCALE = 100,0000 ' / in.	CHECKED -	REVISED - R. SHAH 10-25-94
PLOT DATE = 1/27/2021	DATE - 07-25-90	REVISED - R. SHAH 06-12-96

**STATE OF ILLINOIS
DEPARTMENT OF TRANSPORTATION**

**DETAIL OF STORM SEWER
CONNECTION TO EXISTING SEWER**

SCALE: NONE SHEET 1 OF 1 SHEETS STA. TO STA.

F.A.P. RTE.	SECTION	COUNTY	TOTAL SHEETS	SHEET NO.
303	(134&134XIN	LAKE	129	98
BD500-01 (BD-7)			CONTRACT NO. 60V39	
ILLINOIS FED. AID PROJECT				

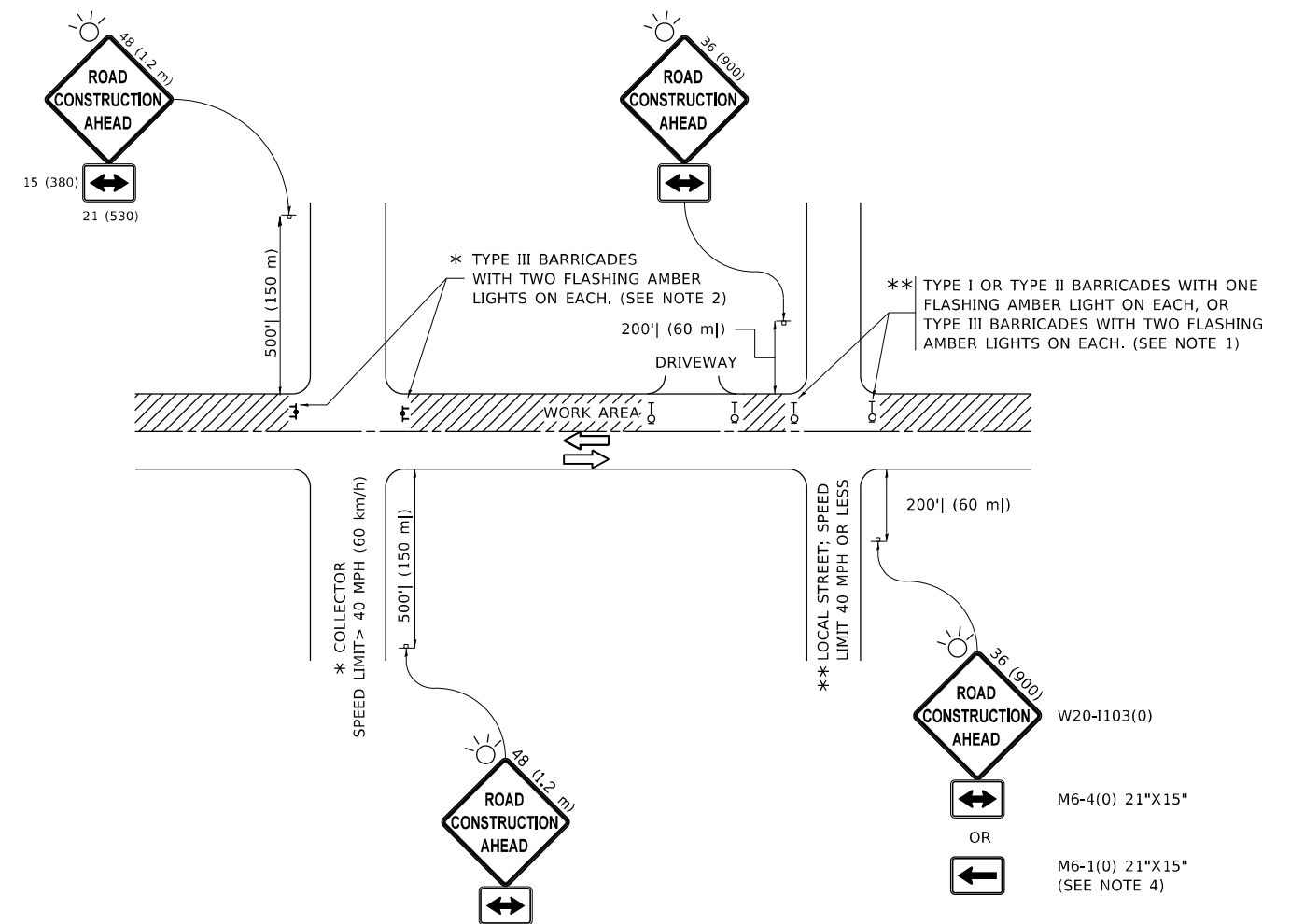

NOTES:

1. SIDE ROAD WITH A SPEED LIMIT OF 40 MPH (60 km/h) OR LESS AS SHOWN ON THE DRAWING AND AS DIRECTED BY THE ENGINEER:
 - a) ONE "ROAD CONSTRUCTION AHEAD" SIGN 36 x 36 (900x900) WITH A FLASHER MOUNTED ON IT APPROXIMATELY 200' (60 m) IN ADVANCE OF THE MAIN ROUTE.
 - b) THE CLOSED PORTION OF THE MAIN ROUTE SHALL BE PROTECTED BY BLOCKING WITH TYPE I, TYPE II OR TYPE III BARRICADES, 1/3 OF THE CROSS SECTION OF THE CLOSED PORTION.
2. SIDE ROAD WITH A SPEED LIMIT GREATER THAN 40 MPH (60 km/h) AS SHOWN ON THE DRAWING AND AS DIRECTED BY THE ENGINEER:
 - a) ONE "ROAD CONSTRUCTION AHEAD" SIGN 48 x 48 (1.2 m x 1.2 m) WITH A FLASHER MOUNTED ON IT APPROXIMATELY 500' (150 m) IN ADVANCE OF THE MAIN ROUTE.
 - b) BLOCKING WITH TYPE III BARRICADES, 1/2 OF THE CROSS SECTION OF THE CLOSED PORTION.
3. CONES MAY BE SUBSTITUTED FOR BARRICADES OR DRUMS AT HALF THE SPACING DURING DAY OPERATIONS. CONES SHALL BE A MINIMUM OF 28 (710) IN HEIGHT.
4. SIGNING AND THE WORK ZONE, A SINGLE HEADED ARROW (M6-1) SHALL BE USED IN LIEU OF THE DOUBLE HEADED ARROW (M6-4).
5. WHEN WORK IS BEING PERFORMED ON A SIDE ROAD OR DRIVEWAY, FOLLOW THE APPLICABLE STANDARD(S). THE DIRECTIONAL ARROW (M6-1 OR M6-4) SHALL BE COVERED OR REMOVED WHEN NO LONGER CONSISTENT WITH THE TRAFFIC CONTROL SET-UP.
6. ADVANCE WARNING SIGNS ARE TO BE OMITTED ON DRIVEWAYS UNLESS OTHERWISE SPECIFIED IN THE PLANS OR BY THE ENGINEER.
7. THE TRAFFIC CONTROL AND PROTECTION FOR SIDE ROADS, INTERSECTIONS, AND DRIVEWAYS SHALL BE INCLUDED IN THE COST OF SPECIFIED TRAFFIC CONTROL STANDARDS OR ITEMS.

All dimensions are in inches (millimeters) unless otherwise shown.

MODEL: Default
FILE NAME: p:\data\m300m.dwt\illinois.gov\PWIDOT\Documents\IBDOT_Offices\Dist\refc_1\Project\171209\ICAD\DATA\Design\Dist\Std.dgn

USER NAME = kalorm	DESIGNED - L.H.A.	REVISED - A. HOUSEH 10-15-96
PLOT SCALE = 100,0000' / in.	CHECKED -	REVISED - T. RAMMACHER 01-06-00
PLOT DATE = 1/27/2021	DATE - 06-89	REVISED - A. SCHUETZE 07-01-13
		REVISED - A. SCHUETZE 09-15-16

**STATE OF ILLINOIS
DEPARTMENT OF TRANSPORTATION**

**TRAFFIC CONTROL AND PROTECTION FOR
SIDE ROADS, INTERSECTIONS, AND DRIVEWAYS**

SCALE: NONE SHEET 1 OF 1 SHEETS STA. TO STA.

F.A.P. RTE.	SECTION	COUNTY	TOTAL SHEETS	SHEET NO.
303	(134&134X)N	LAKE	129	99
TC-10			CONTRACT NO. 60V39	
ILLINOIS FED. AID PROJECT				

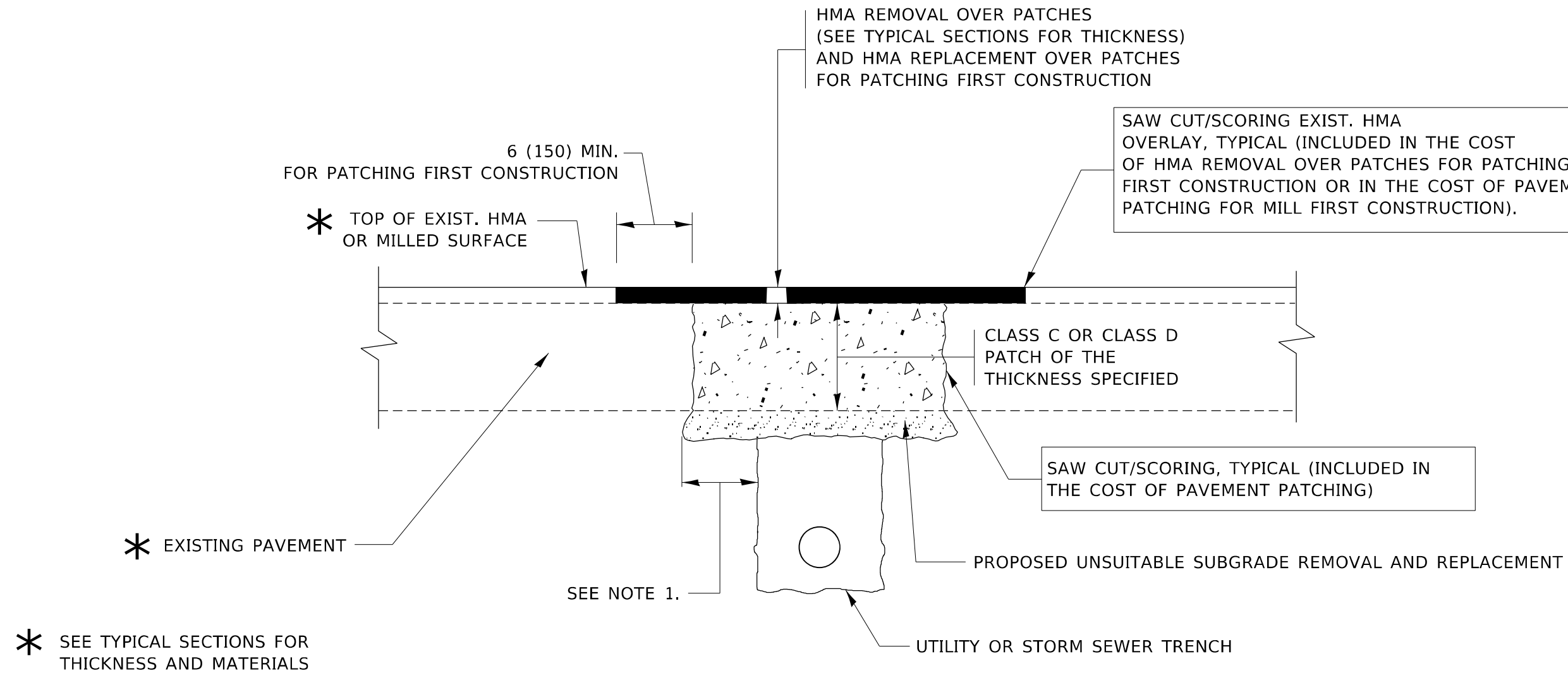

NOTES:

1. THE WIDTH OF THE FULL DEPTH PATCH OVER A TRENCH SHALL BE 12 (300) WIDER ON EACH SIDE OF THE TRENCH.
2. FOR METHOD OF MEASUREMENT AND BASIS OF PAYMENT, SEE RECURRING SPECIAL PROVISION "PATCHING WITH HOT-MIX ASPHALT OVERLAY REMOVAL".

SEQUENCE OF CONSTRUCTION (PATCHING FIRST)

1. REMOVE THE EXISTING HMA MATERIAL OVER THE AREA TO BE PATCHED.
2. REMOVE AND REPLACE WITH CLASS C OR D PATCH.
3. REPLACE HMA MATERIAL OVER THE AREA TO BE PATCHED.

SEQUENCE OF CONSTRUCTION (MILLING FIRST)

1. MILL HMA FIRST IF THERE IS AT LEAST 4½ INCHES OR MORE OF HMA MATERIAL ON TOP OF THE EXISTING PAVEMENT OR IF THE PAVEMENT IS FULL DEPTH HMA. A MINIMUM OF 2 INCHES OF HMA MATERIAL SHALL BE IN PLACE AFTER MILLING.
2. REMOVE AND REPLACE WITH FULL DEPTH CLASS D PATCHES TO TOP OF MILLED SURFACE.

ALL DIMENSIONS ARE IN INCHES (MILLIMETERS) UNLESS OTHERWISE SHOWN.

MODEL: Default
FILE NAME: p:\data\mroom.edu\illinois.gov\pww\DOT\Documents\DOT_Offices\Bates\1\Project\171099\CADD\data\Design\0815\Std.dgn

USER NAME = kalorm	DESIGNED - R. SHAH	REVISED - A. ABBAS 04-27-98
	DRAWN -	REVISED - R. BORO 01-01-07
PLOT SCALE = 100,0000' / in.	CHECKED -	REVISED - R. BORO 09-04-07
PLOT DATE = 1/27/2021	DATE - 10-25-94	REVISED - K. ENG 10-27-08

**STATE OF ILLINOIS
DEPARTMENT OF TRANSPORTATION**

**PAVEMENT PATCHING FOR
HMA SURFACED PAVEMENT**

SCALE: NONE SHEET 1 OF 1 SHEETS STA. TO STA.

F.A.P. RTE.	SECTION	COUNTY	TOTAL SHEETS	SHEET NO.
303	(134&134XIN	LAKE	129	100
BD400-04 (BD-22)			CONTRACT NO. 60V39	
ILLINOIS FED. AID PROJECT				

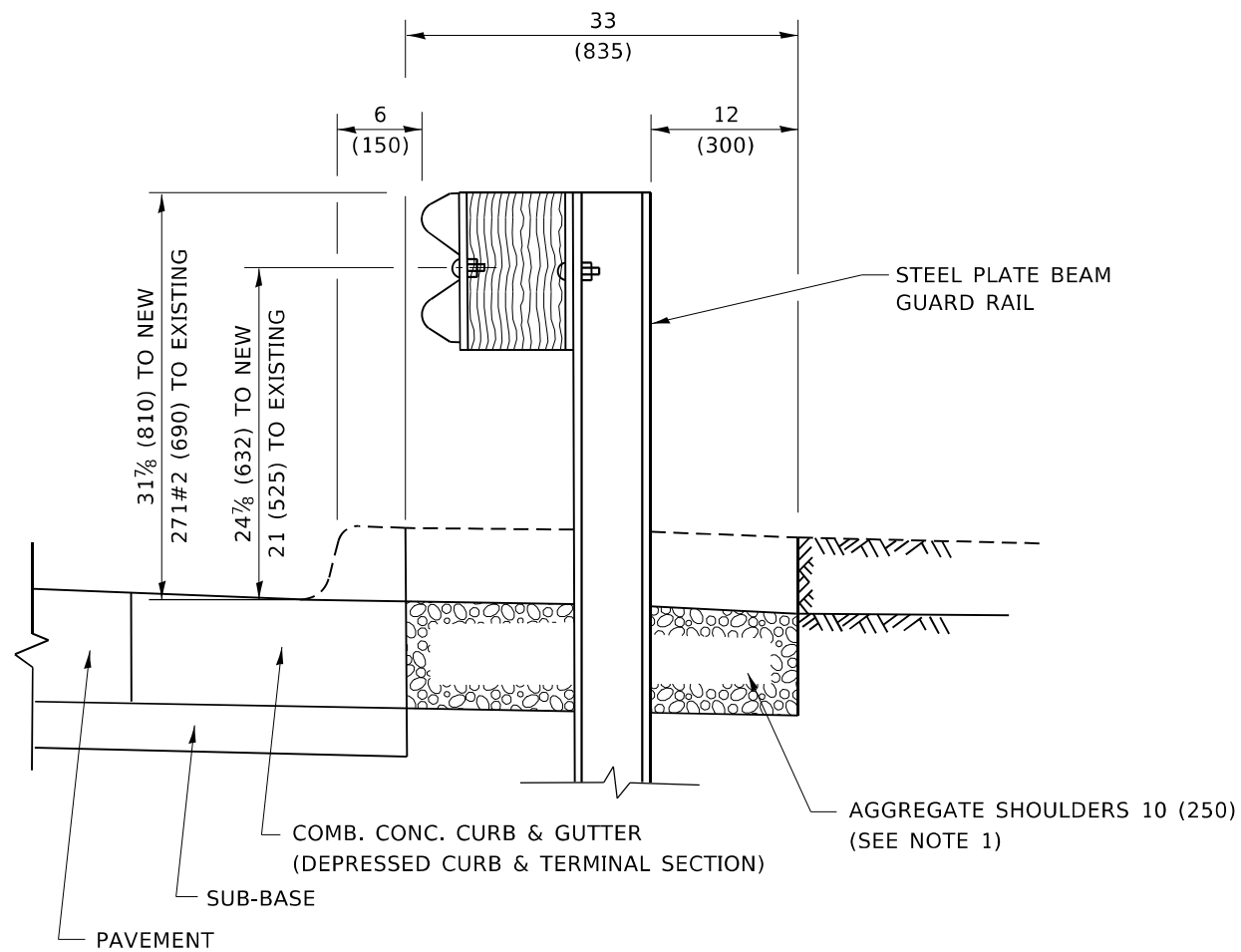

SECTION A-A

NOTES:

1. THE AGGREGATE SHOULDER, 10 (250) OR HMA SHOULDER, 6 (150) (IF REQUIRED) SHALL EXTEND UNDER THE TRAFFIC BARRIER TERMINAL.
2. "EXISTING" GUARDRAIL REFERS TO CONNECTING TERMINAL SECTION TO GUARD RAILING PRIOR TO THE MIDWEST GUARDRAIL SYSTEM.
3. THE CONTRACTOR SHALL VERIFY THE TYPE/HEIGHT OF GUARDRAIL IN-PLACE BEFORE ORDERING THE NEW TERMINAL SECTION. COST INCLUDED WITH THE COST OF THE TERMINAL. THE TERMINAL SECTION HEIGHT TO BE PLACED MUST MATCH THE HEIGHT OF THE IN-PLACE GUARDRAIL.

**DETAILS FOR STEEL PLATE BEAM
GUARD RAIL ADJACENT TO CURB AND GUTTER
[FOR ROADWAY SPEED 35 MPH (60 kmh) TO 45 MPH (70 kmh)]**

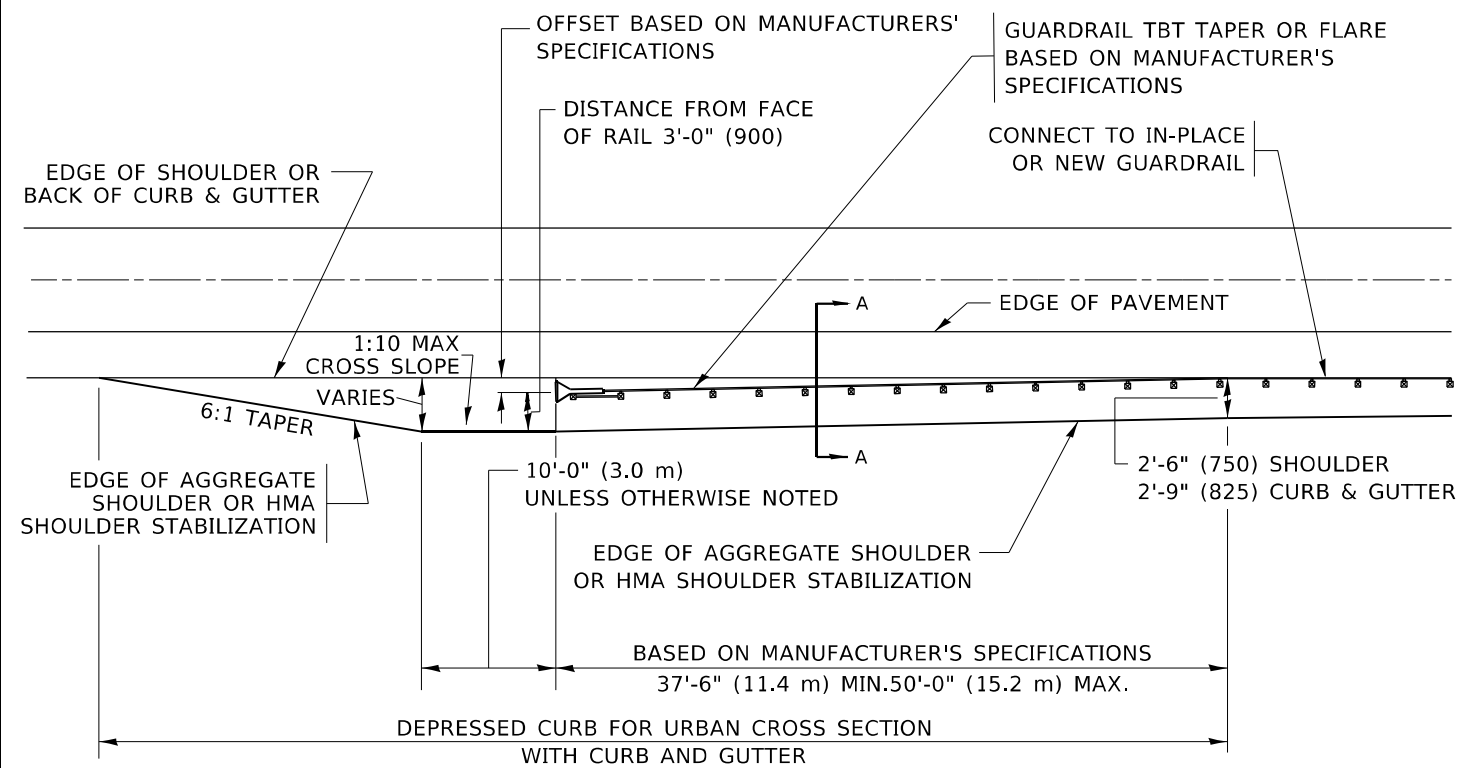

**DEPRESSED CURB AND GUTTER AND
SHOULDER TREATMENT AT TBT TY. 1 SPL.**

AGGREGATE SHOULDER, 10 (250) WILL BE PAID ACCORDING TO SECTION 481.

HMA SHOULDERS 6 (150) (IF REQUIRED) WILL BE PAID ACCORDING TO SECTION 482.

COMB. CONC. C&G, STEEL PLATE BEAM GUARD RAIL AND TRAFFIC BARRIER TERMINAL, OF THE TYPE SPECIFIED WILL BE PAID FOR SEPARATELY.

TBT = TRAFFIC BARRIER TERMINAL
ALL DIMENSIONS ARE IN INCHES (MILLIMETERS)
UNLESS OTHERWISE SHOWN.

MODEL: Default
FILE NAME: p:\mtd\mtdroom.dwg
PROJECT: P171099\CD\Drawings\DOT_Office\Drawings\171099\CD\Drawings\Detail\Detail.dwg

USER NAME = kalorm	DESIGNED - M. DE YONG	REVISED - R. BORO 12-08-2008
	DRAWN -	REVISED - R. BORO 09-14-2009
PLOT SCALE = 100,0000' / in.	CHECKED -	REVISED - R. BORO 08-06-2012
PLOT DATE = 3/8/2021	DATE - 09-22-90	REVISED - R. BORO 05-08-2015

**STATE OF ILLINOIS
DEPARTMENT OF TRANSPORTATION**

**DETAILS FOR DEPRESSED CURB & GUTTER AND
SHOULDER TREATMENT AT TBT TY. 1 SPL.**

SCALE: NONE SHEET 1 OF 1 SHEETS STA. TO STA.

F.A.P. RTE.	SECTION	COUNTY	TOTAL SHEETS	SHEET NO.
303	(134&134XIN	LAKE	129	101A
BD600-10 (BD 34)			CONTRACT NO. 60V39	
ILLINOIS FED. AID PROJECT				

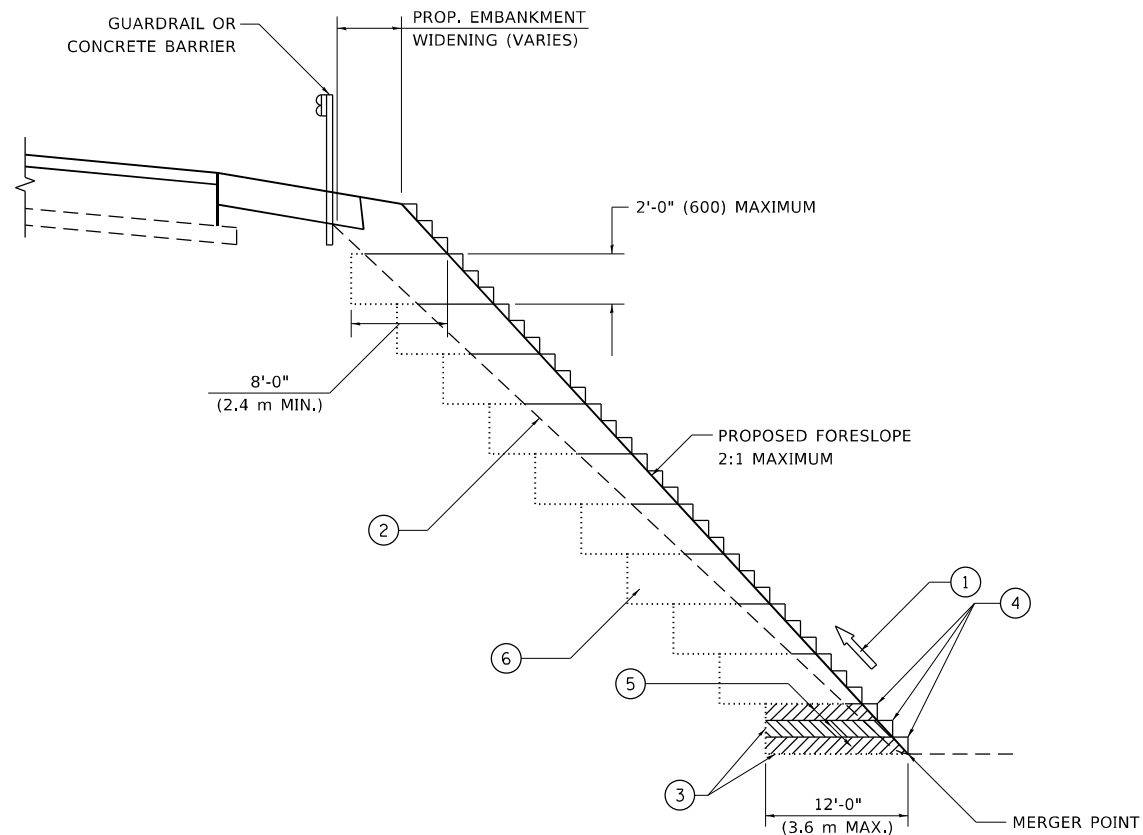

**TYPICAL BENCHING DETAIL
FOR EMBANKMENT**

NOTES:

- ① CONSTRUCT SUCCEEDING BENCH CUTS AND EMBANKMENT PLACEMENT AND COMPACTION FROM BOTTOM TO TOP IN STAIRSTEP FASHION.
- ② EXISTING FORESLOPE PREPARED IN ACCORDANCE WITH ARTICLE 205.03 OF THE STANDARD SPECIFICATIONS.
- ③ BENCH CUT EXISTING SLOPE TYPICAL FOR EACH STEP.
- ④ TRIM TO FINAL SLOPE.
- ⑤ EQUAL 8-INCH (200) LIFTS OF EMBANKMENT COMPACTED IN ACCORDANCE WITH ARTICLE 205.05 OF THE STANDARD SPECIFICATIONS.
- ⑥ EXCAVATION OF BENCH CUTS WITHIN EXISTING EMBANKMENT WILL BE PAID FOR AT THE CONTRACT UNIT PRICE PER CUBIC METER OR CUBIC YARD FOR "EARTH EXCAVATION". THIS PRICE WILL INCLUDE ALL LABOR AND MATERIAL, NO ADDITIONAL COMPENSATION WILL BE ALLOWED.
- ⑦ SLOPES SHALL BE BENCHED ACCORDING TO THIS DETAIL WHEN THE SLOPE IS STEEPER THAN 4:1 AND THE HEIGHT IS GREATER THAN 5' (1.5 m).

ALL DIMENSIONS ARE IN INCHES (MILLIMETERS)
UNLESS OTHERWISE SHOWN.

MODEL: Default
FILE NAME: p:\data\mroom.dwg
PROJECT: P171099\CADD\DATA\Design\Dist\Std.dgn

USER NAME = kalorm	DESIGNED -	REVISED -
PLOT SCALE = 100,0000 ' / in.	DRAWN - CADD	REVISED -
PLOT DATE = 1/27/2021	CHECKED - S.E.B.	REVISED -
	DATE - 06-16-04	REVISED -

**STATE OF ILLINOIS
DEPARTMENT OF TRANSPORTATION**

BENCHING DETAIL FOR EMBANKMENT WIDENING			
SCALE: NONE	SHEET 1	OF 1 SHEETS	STA. TO STA.

F.A.P. RTE.	SECTION	COUNTY	TOTAL SHEETS	SHEET NO.
303	(134&134XIN	LAKE	129	102
BD-51		CONTRACT NO. 60V39		
ILLINOIS FED. AID PROJECT				

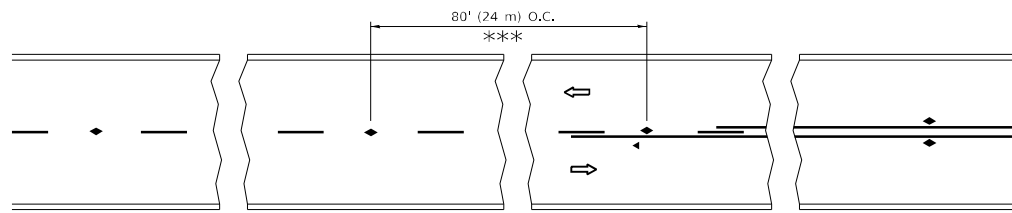

*** REDUCE TO 40' (12 m) O.C. ON CURVES WITH POSTED OR ADVISORY SPEED 45 M.P.H. (70 km/h) OR LESS.

TWO-LANE/TWO-WAY

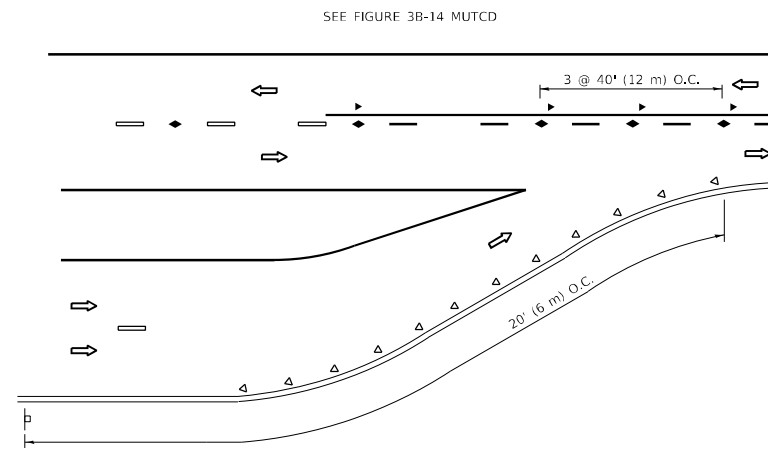

LANE REDUCTION TRANSITION

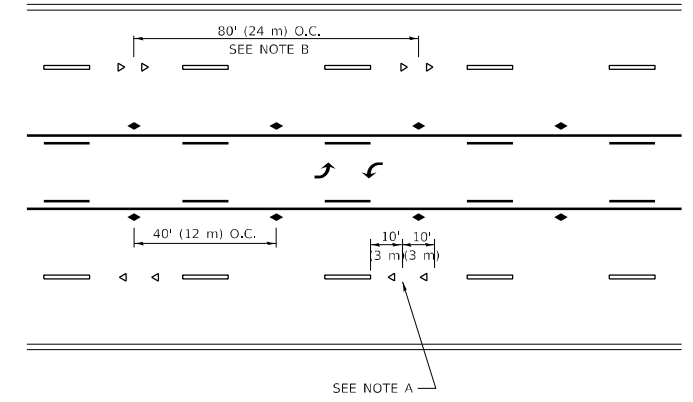

TWO-WAY LEFT TURN

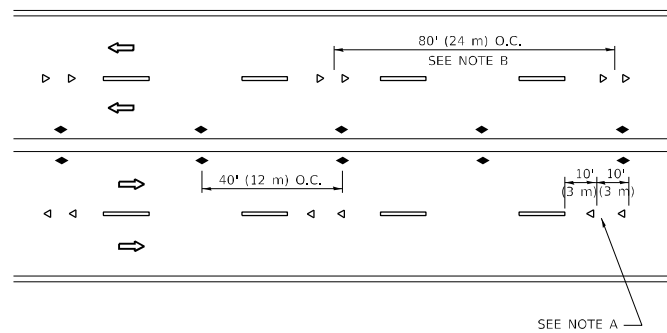

MULTI-LANE/UNDIVIDED

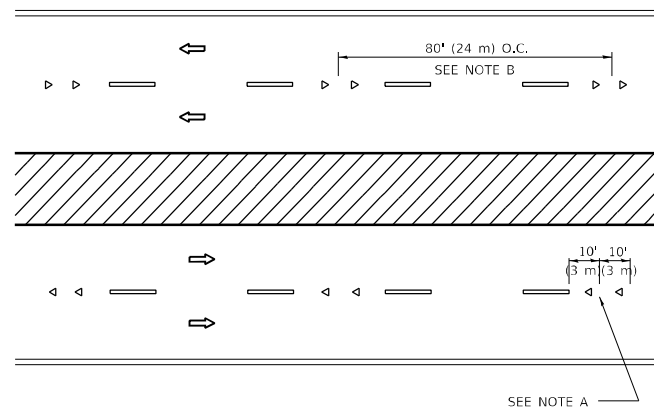

MULTI-LANE/DIVIDED

GENERAL NOTES

1. MARKERS USED WITH DASHED LINES SHALL BE CENTERED IN THE GAP BETWEEN SEGMENTS.
2. MARKERS USED ADJACENT TO SOLID LINES SHALL BE OFFSET 2 TO 3 (50 TO 75) TOWARD TRAFFIC AS SHOWN.
3. MARKERS THROUGH TANGENTS LESS THAN 500' (150 m) IN LENGTH BETWEEN CURVES SHALL BE INSTALLED AT THE LESSER OF THE TWO CURVE SPACINGS.
4. MARKERS ARE TO BE USED ADJACENT TO BOTH SOLID WHITE LINES IN DUAL LEFT TURN LANES

SYMBOLS

- YELLOW STRIPE
- WHITE STRIPE
- ◀ ONE-WAY AMBER MARKER
- ◀ ONE-WAY CRYSTAL MARKER (W/O)
- ◆ TWO-WAY AMBER MARKER

LANE MARKER NOTES

- A. USE DOUBLE LANE LINE MARKERS SPACED AS SHOWN.
- B. REDUCE TO 40' (12 m) O.C. ON CURVES WHERE ADVISORY SPEEDS ARE 10 M.P.H. (20 km/h) LOWER THAN POSTED SPEEDS.

DESIGN NOTES

1. DOUBLE LANE LINE MARKERS SHALL BE USED UNLESS SPECIFIED OTHERWISE.
2. EXCEPT AS SHOWN ON THE LANE REDUCTION TRANSITION AND FREEWAY EXIT RAMP DETAIL, MARKERS ARE NOT TO BE SPECIFIED ON RIGHT EDGE LINES.
3. THE EXACT MARKER LIMITS, SPACING, AND COLOR SHALL BE INCLUDED IN THE PLANS WHEN STANDARD SPECIFICATIONS ARE NOT BEING USED.
4. MARKERS SHOULD NOT BE USED ALONGSIDE CURBS EXCEPT FOR EXTREMELY SHORT SECTIONS OF CURBS WHERE NOT MORE THAN TWO MARKERS WOULD BE INVOLVED.

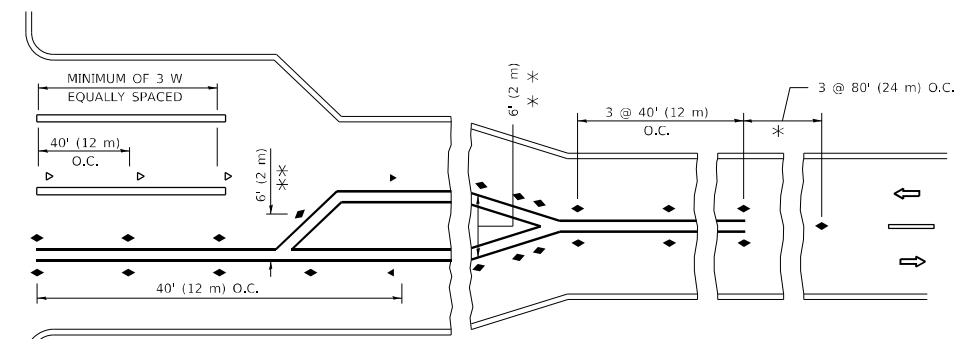
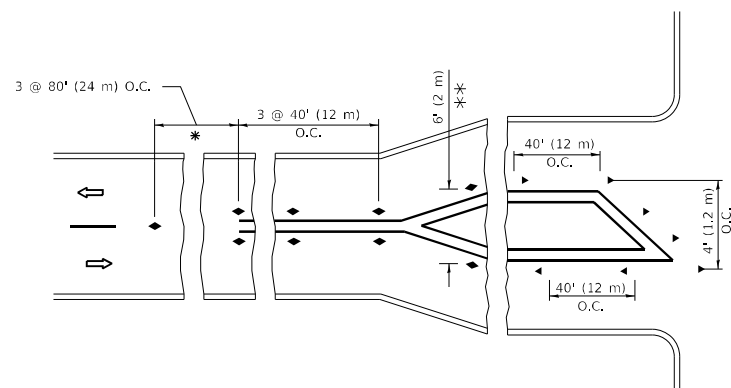

TURN LANES

* SEE TWO-LANE/TWO-WAY WHERE MARKERS CONTINUE
 ** WHERE THE MEDIAN WIDTH IS 6' (2 m) OR LESS USE TWO-WAY MARKERS.

All dimensions are in inches (millimeters) unless otherwise shown.

MODEL: Default
 FILE NAME: p:\data\m3000.dwg
 PROJECT: P171909\CADD\DATA\Design\DistStd.dgn

USER NAME = kalorm	DESIGNED -	REVISED - T. RAMMACHER 03-12-99
	DRAWN -	REVISED - T. RAMMACHER 01-06-00
PLOT SCALE = 100,0000' / in.	CHECKED -	REVISED - C. JUCIUS 09-09-09
PLOT DATE = 1/27/2021	DATE -	REVISED - C. JUCIUS 07-01-13

**STATE OF ILLINOIS
 DEPARTMENT OF TRANSPORTATION**

**TYPICAL APPLICATIONS
 RAISED REFLECTIVE PAVEMENT MARKERS (SNOW-PLOW RESISTANT)**

SCALE: NONE SHEET 1 OF 1 SHEETS STA. TO STA.

F.A.P. RTE. 303	SECTION (134&134XIN)	COUNTY LAKE	TOTAL SHEETS 129	SHEET NO. 103
TC-11		CONTRACT NO. 60V39		
ILLINOIS FED. AID PROJECT				

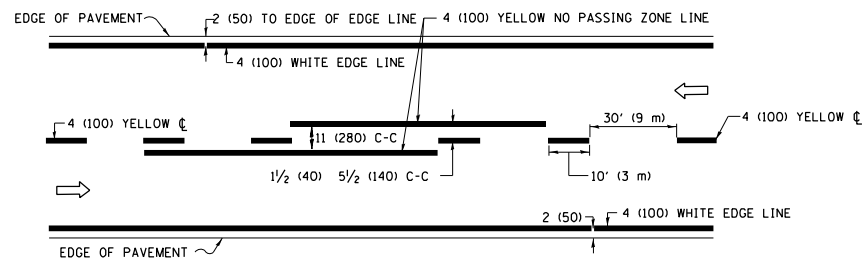

2-LANE ROADWAY

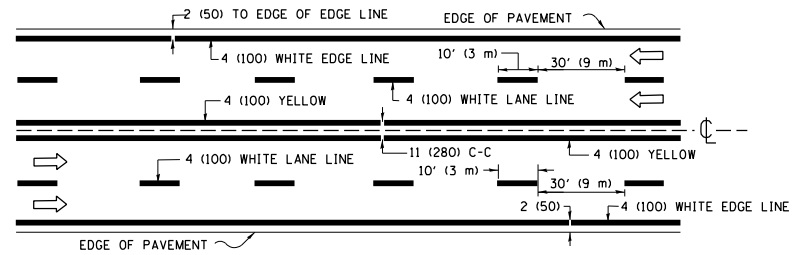

MULTI-LANE UNDIVIDED

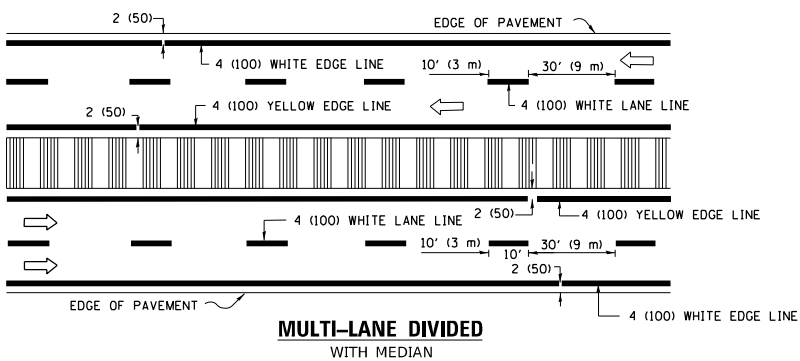

MULTI-LANE DIVIDED WITH MEDIAN

TYPICAL LANE AND EDGE LINE MARKING

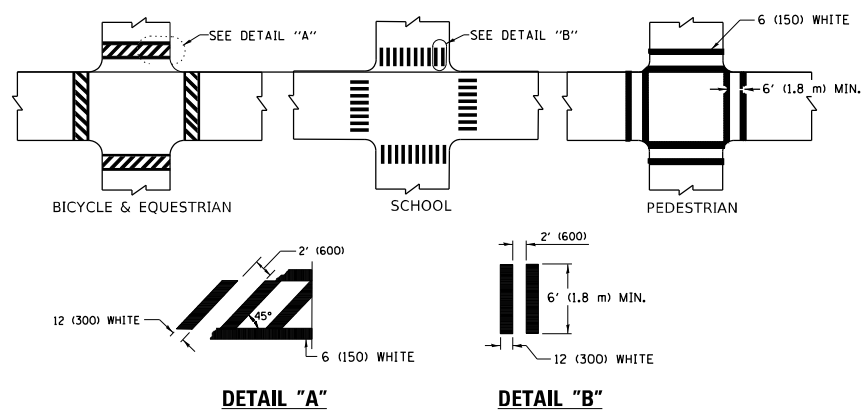

TYPICAL CROSSWALK MARKING

* MARKINGS SHALL BE INSTALLED PARALLEL TO THE CENTERLINE OF THE ROAD WHICH IT CROSSES

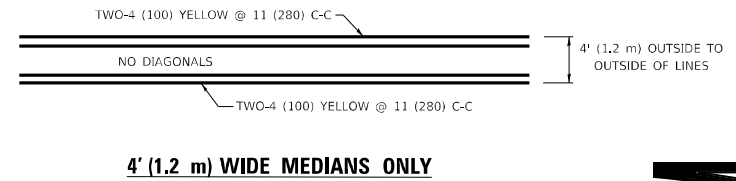

4' (1.2 m) WIDE MEDIANS ONLY

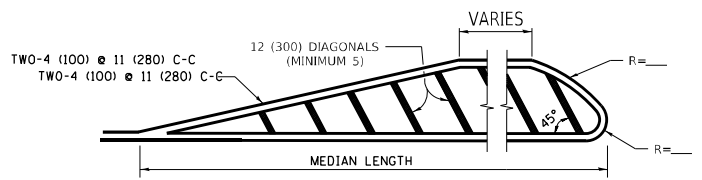

MEDIANS OVER 4' (1.2 m) WIDE

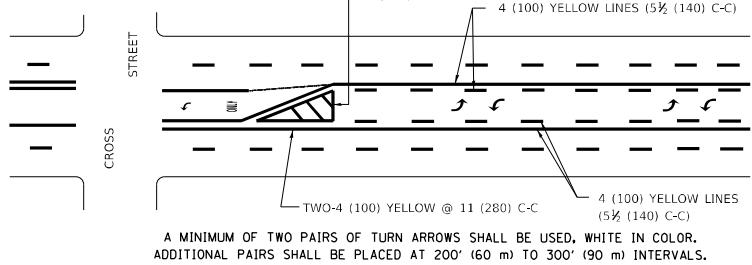

MEDIAN WITH TWO-WAY LEFT TURN LANE TYPICAL PAINTED MEDIAN MARKING

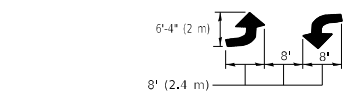

TYPICAL LEFT (OR RIGHT) TURN LANE

TYPICAL TURN LANE MARKING

FULL SIZE LETTERS 8" (2.4 m) AND ARROWS SHALL BE USED.
 * AREA = 15.6 SQ. FT. (1.5 m²) ONLY AREA = 20.8 SQ. FT. (1.9 m²)
 * TURN LANES IN EXCESS OF 400' (120 m) IN LENGTH MAY HAVE AN ADDITIONAL SET OF ARROW - "ONLY" INSTALLED MIDWAY BETWEEN THE OTHER TWO SETS OF ARROW - "ONLY".

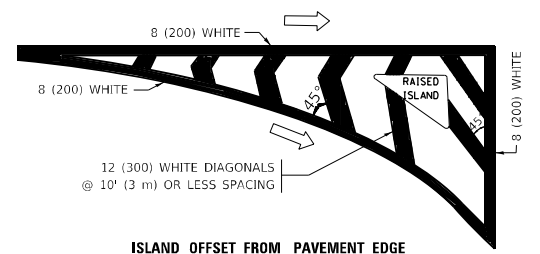

ISLAND OFFSET FROM PAVEMENT EDGE

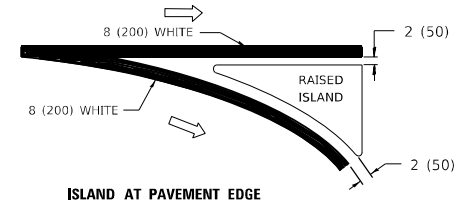

ISLAND AT PAVEMENT EDGE

TYPICAL ISLAND MARKING

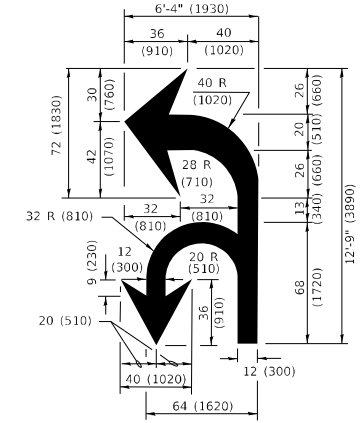

COMBINATION LEFT AND U-TURN

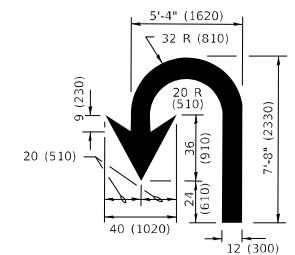

U-TURN

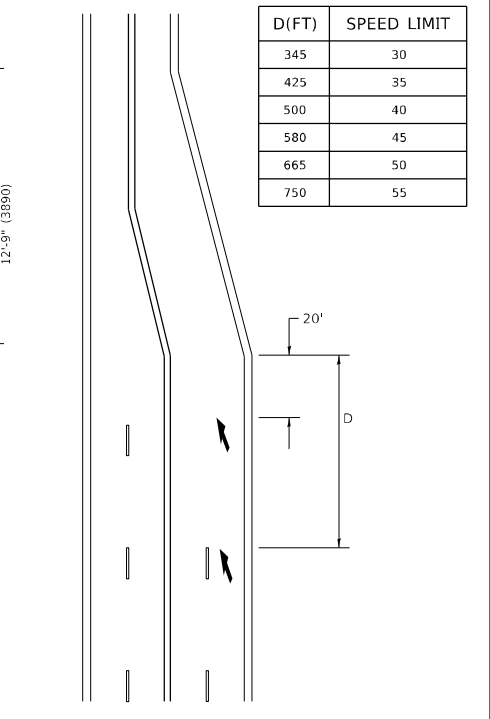

LANE REDUCTION TRANSITION
 * LANE REDUCTION ARROWS REQUIRED AT SPEEDS OF 45 MPH OR GREATER OR WHEN SPECIFIED IN PLANS.

D(FT)	SPEED LIMIT
345	30
425	35
500	40
580	45
665	50
750	55

TYPE OF MARKING	WIDTH OF LINE	PATTERN	COLOR	SPACING / REMARKS
CENTERLINE ON 2 LANE PAVEMENT	4 (100)	SKIP-DASH	YELLOW	10' (3 m) LINE WITH 30' (9 m) SPACE
CENTERLINE ON MULTI-LANE UNDIVIDED PAVEMENT	2 @ 4 (100)	SOLID	YELLOW	11 (280) C-C
NO PASSING ZONE LINES: FOR ONE DIRECTION FOR BOTH DIRECTIONS	4 (100) 2 @ 4 (100)	SOLID SOLID	YELLOW YELLOW	5 1/2 (140) C-C FROM SKIP-DASH CENTERLINE 11 (280) C-C OMIT SKIP-DASH CENTERLINE BETWEEN
LANE LINES	4 (100) 5 (125) ON FREEWAYS	SKIP-DASH SKIP-DASH	WHITE WHITE	10' (3 m) LINE WITH 30' (9 m) SPACE
DOTTED LINES (EXTENSIONS OF CENTER, LANE OR TURN LANE MARKINGS)	SAME AS LINE BEING EXTENDED	SKIP-DASH	SAME AS LINE BEING EXTENDED	2' (600) LINE WITH 6' (1.8 m) SPACE
EDGE LINES	4 (100)	SOLID	YELLOW-LEFT WHITE-RIGHT	OUTLINE MEDIANS IN YELLOW
TURN LANE MARKINGS	6 (150) LINE; FULL SIZE LETTERS & SYMBOLS (8" (2.4m))	SOLID	WHITE	SEE TYPICAL TURN LANE MARKING DETAIL
TWO WAY LEFT TURN MARKING	2 @ 4 (100) EACH DIRECTION 8" (2.4m) LEFT ARROW	SKIP-DASH AND SOLID IN PAIRS	YELLOW WHITE	10' (3 m) LINE WITH 30' (9 m) SPACE FOR SKIP-DASH; 5 1/2 (140) C-C BETWEEN SOLID LINE AND SKIP-DASH LINE SEE TYPICAL TWO-WAY LEFT TURN MARKING DETAIL
CROSSWALK LINES (PEDESTRIAN) A. DIAGONALS (BIKE & EQUESTRIAN) B. LONGITUDINAL BARS (SCHOOL)	2 @ 6 (150) 12 (300) @ 45° 12 (300) @ 90°	SOLID SOLID SOLID	WHITE WHITE WHITE	NOT LESS THAN 6' (1.8 m) APART 2' (600) APART 2' (600) APART SEE TYPICAL CROSSWALK MARKING DETAILS.
STOP LINES	24 (600)	SOLID	WHITE	PLACE 4' (1.2 m) IN ADVANCE OF AND PARALLEL TO CROSSWALK, IF PRESENT. OTHERWISE, PLACE AT DESIRED STOPPING POINT, PARALLEL TO CROSSROAD CENTERLINE, WHERE POSSIBLE
PAINTED MEDIANS	2 @ 4 (100) WITH 12 (300) DIAGONALS @ 45° NO DIAGONALS USED FOR 4' (1.2 m) WIDE MEDIANS	SOLID	YELLOW: TWO WAY TRAFFIC WHITE: ONE WAY TRAFFIC	11 (280) C-C FOR THE DOUBLE LINE SEE TYPICAL PAINTED MEDIAN MARKING.
GORE MARKING AND CHANNELIZING LINES	8 (200) WITH 12 (300) DIAGONALS @ 45°	SOLID	WHITE	DIAGONALS: 15' (4.5 m) C-C (LESS THAN 30MPH (50 km/h)) 20' (6 m) C-C 30MPH (50 km/h) TO 45MPH (70 km/h)) 30' (9 m) C-C (OVER 45MPH (70 km/h))
RAILROAD CROSSING	24 (600) TRANSVERSE LINES: "RR" IS 8' (1.8 m) LETTERS: 16 (400) LINE FOR "X"	SOLID	WHITE	SEE STATE STANDARD 780001 AREA OF: "R"=3.6 SQ. FT. (0.33 m ²) EACH "X"=54.0 SQ. FT. (5.0 m ²)
SHOULDER DIAGONALS (REQUIRED FOR SHOULDERS ≥ 8')	12 (300) @ 45°	SOLID	WHITE - RIGHT YELLOW - LEFT	50' (15 m) C-C (LESS THAN 30MPH (50 km/h)) 75' (25 m) C-C (30 MPH (50 km/h) TO 45MPH (70 km/h)) 150' (45 m) C-C (OVER 45MPH (70 km/h))
U TURN ARROW	SEE DETAIL	SOLID	WHITE	16.3 SF
2 ARROW COMBINATION LEFT AND U TURN	SEE DETAIL	SOLID	WHITE	30.4 SF

FOR FURTHER DETAILS ON PAVEMENT MARKING REFER TO STANDARD SPECIFICATIONS FOR ROAD AND BRIDGE CONSTRUCTION AND STATE STANDARD 780001.

All dimensions are in inches (millimeters) unless otherwise shown.

MODEL: Default
 FILE: \\hpc-001\public\pwworkspace\11491526\17192091\11491526.dwg
 PROJECT: P17192091\11491526.dwg
 USER: DJR
 DATE: 1/27/2021 10:05:00 AM
 PLOT DATE: 1/27/2021 10:05:00 AM
 PLOT SCALE: 1/16" = 1'-0"

USER NAME	DESIGNED	REVISOR	DATE
USER NAME = kalarr	DESIGNED - EVERS	REVISOR - C. JUCIUS	DATE - 09-09-09
	DRAWN -	REVISOR - C. JUCIUS	DATE - 07-01-13
	CHECKED -	REVISOR - C. JUCIUS	DATE - 12-21-15
	DATE - 03-19-90	REVISOR - C. JUCIUS	DATE - 04-12-16

**STATE OF ILLINOIS
 DEPARTMENT OF TRANSPORTATION**

DISTRICT ONE TYPICAL PAVEMENT MARKINGS			
SCALE	SHEET	OF SHEETS	STA. TO STA.
NONE	1	2	STA. TO STA.

F.A.P. RTE.	SECTION	COUNTY	TOTAL SHEETS	SHEET NO.
303	(134&134XIN	LAKE	129	104
TC-13			CONTRACT NO. 60V39	
ILLINOIS FED. AID PROJECT				

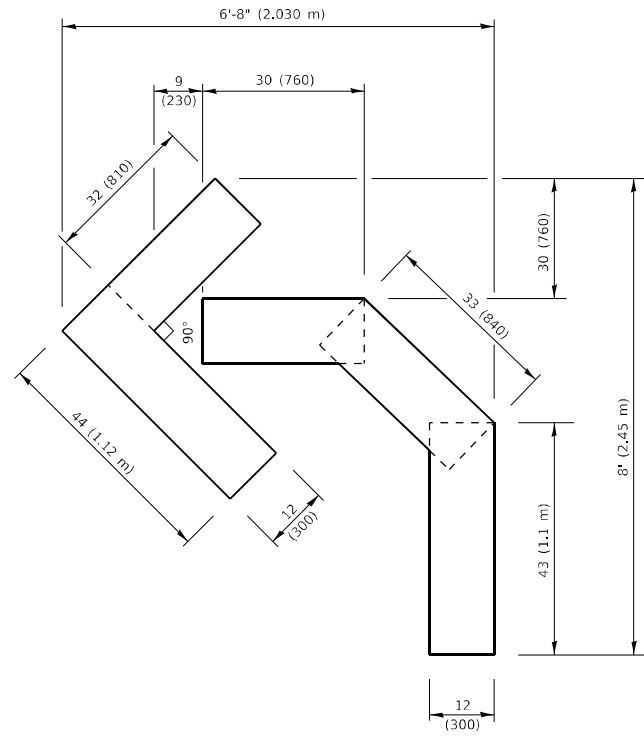

QUANTITY

4 (100) LINE = 45.5 ft. (13.9 m)
15.2 sq. ft. (1.41 sq. m)

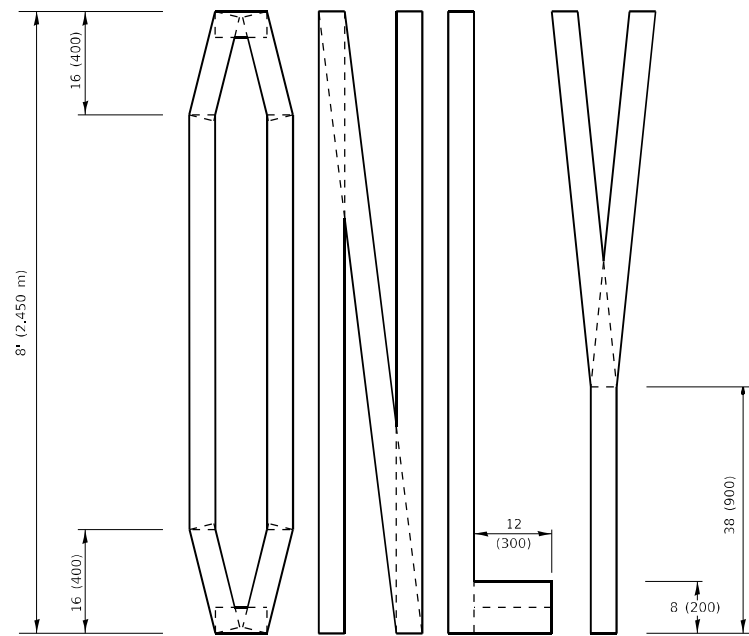
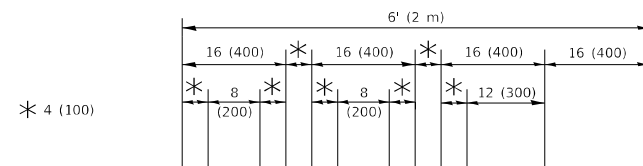

QUANTITY

4 (100) LINE = 64.1 ft. (19.5 m)
21.4 sq. ft. (1.99 sq. m)

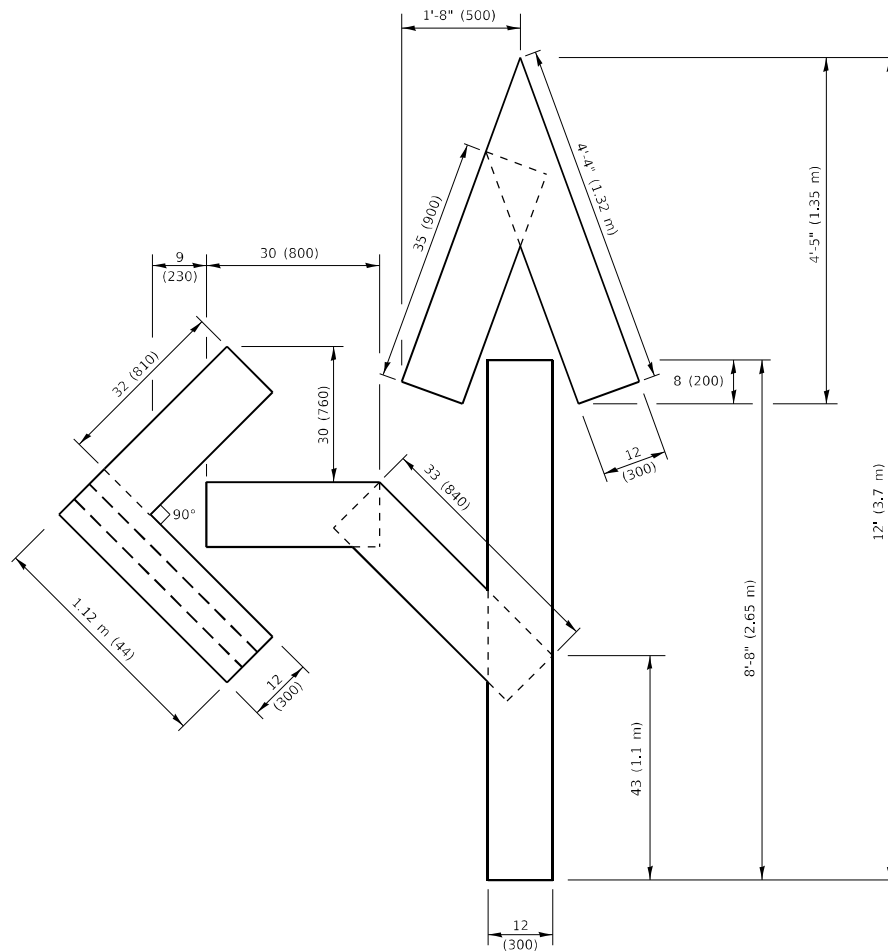

QUANTITY

4 (100) LINE = 82.5 ft. (25.1 m)
27.5 sq. ft. (2.53 sq. m)

NOTE:

ALL QUANTITIES OF PLACEMENT ARE REPRESENTED IN LINEAR FEET OF 4" LINES TO MATCH THE 4" TEMPORARY TAPE PAY ITEM AND REPRESENTS THE TOTAL QUANTITY OF 4" TAPE REQUIRED.

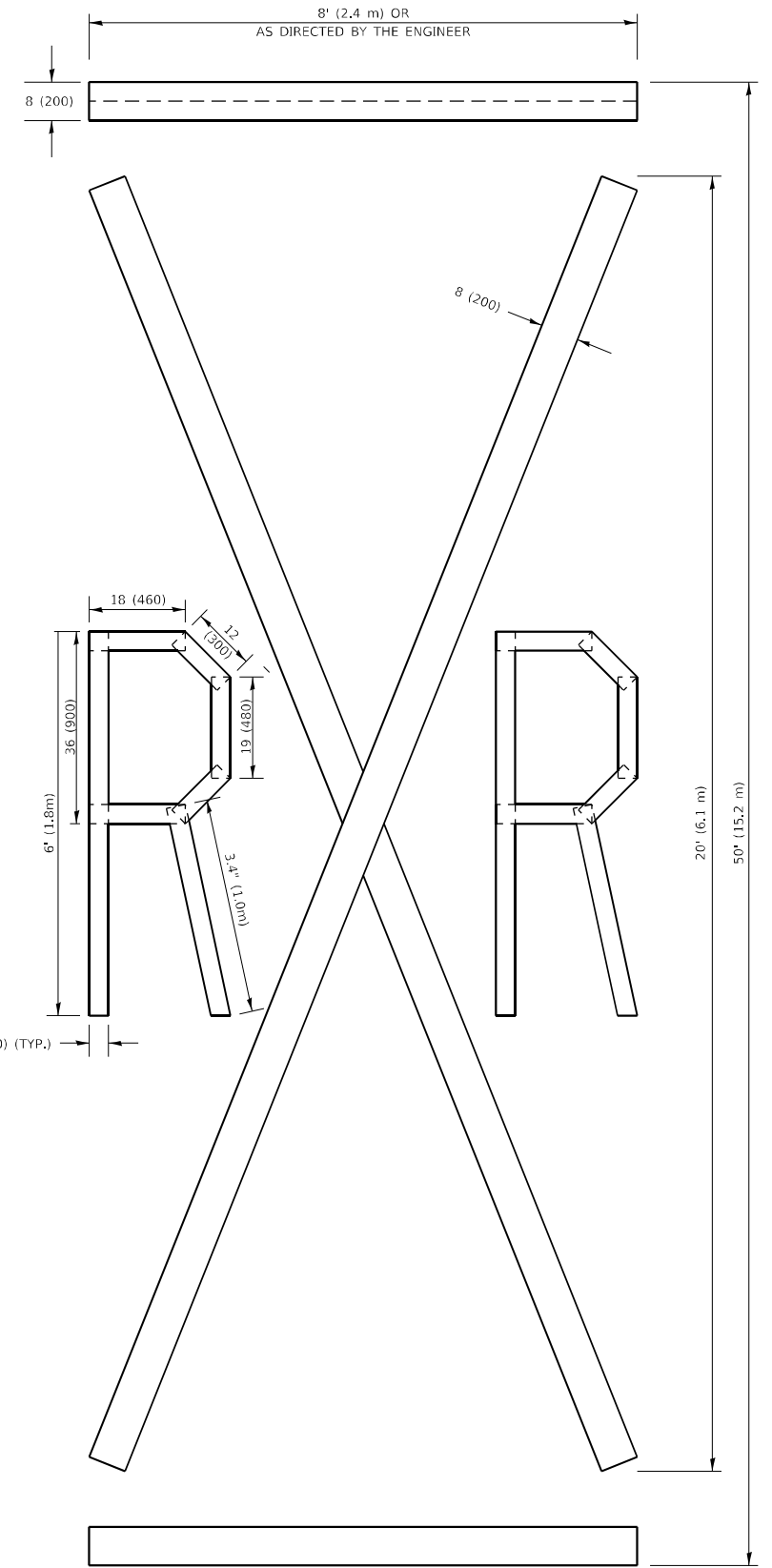

QUANTITY

4 (100) LINE = 225.9 ft. (68.9 m)
75.3 sq. ft. (6.99 sq. m)

All dimensions are in inches (millimeters) unless otherwise shown.

MODEL: Default
FILE: Marking_Plan\plan\DOT\Document\DOT_Offices\District 1\Projects\171909\CO\Drawings\Drawings\Dist5Stg.dwg

USER NAME = kalorn	DESIGNED -	REVISED - T. RAMMACHER 03-02-98
	DRAWN -	REVISED - E. GOMEZ 08-28-00
PLOT SCALE = 100,0010 ' / in.	CHECKED -	REVISED - E. GOMEZ 08-28-00
PLOT DATE = 1/27/2021	DATE - 09-18-94	REVISED - A. SCHUETZE 09-15-16

**STATE OF ILLINOIS
DEPARTMENT OF TRANSPORTATION**

SHORT TERM PAVEMENT MARKING LETTERS AND SYMBOLS

SCALE: NONE SHEET 1 OF 1 SHEETS STA. TO STA.

F.A.P. RTE.	SECTION	COUNTY	TOTAL SHEETS	SHEET NO.
303	(134&134XIN	LAKE	129	105
TC-16			CONTRACT NO. 60V39	
ILLINOIS FED. AID PROJECT				

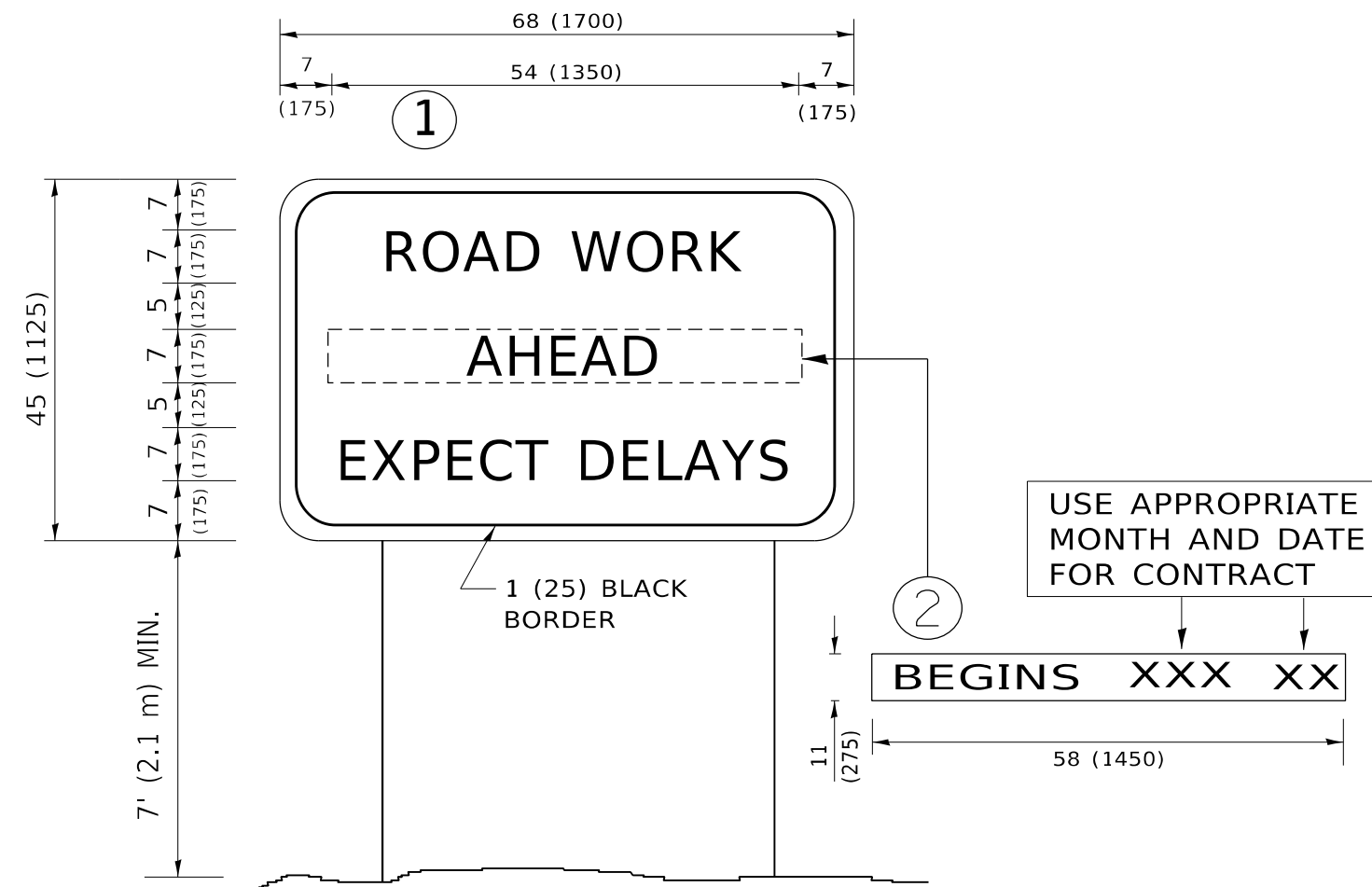

NOTES:

1. USE BLACK LETTERING ON ORANGE BACKGROUND.
2. ERECT SIGNS IN ADVANCE OF THE LOCATION FOR THE "ROAD CONSTRUCTION AHEAD" SIGN AT LOCATIONS AS DIRECTED BY THE ENGINEER.
3. ERECT SIGN ① WITH INSTALLED PANEL ② ONE WEEK PRIOR TO THE START OF CONSTRUCTION.
4. REMOVE PANEL ② SOON AFTER THE START OF CONSTRUCTION.
5. SEE SPECIAL PROVISION FOR "TEMPORARY INFORMATION SIGNING" FOR ADDITIONAL INFORMATION.
6. ONE SIGN ASSEMBLY EQUALS 25.70 SQ. FT. (2.3 SQ. M.)
7. SHALL BE PAID FOR AS TEMPORARY INFORMATION SIGNING.

ALL DIMENSIONS ARE IN INCHES (MILLIMETERS) UNLESS OTHERWISE SHOWN.

MODEL: Default
 FILE NAME: p:\data\mroom.dwg
 PROJECT: P171099\CADD\DATA\Design\DRS\Std.dgn

USER NAME = kalorm	DESIGNED -	REVISED - R. MIRS 09-15-97
	DRAWN -	REVISED - R. MIRS 12-11-97
PLOT SCALE = 100,0000 ' / in.	CHECKED -	REVISED - T. RAMMACHER 02-02-99
PLOT DATE = 1/27/2021	DATE -	REVISED - C. JUCIUS 01-31-07

**STATE OF ILLINOIS
DEPARTMENT OF TRANSPORTATION**

**ARTERIAL ROAD
INFORMATION SIGN**

SCALE: NONE SHEET 1 OF 1 SHEETS STA. TO STA.

F.A.P. RTE.	SECTION	COUNTY	TOTAL SHEETS	SHEET NO.
303	(134&134XIN	LAKE	129	106
TC-22			CONTRACT NO. 60V39	
ILLINOIS FED. AID PROJECT				

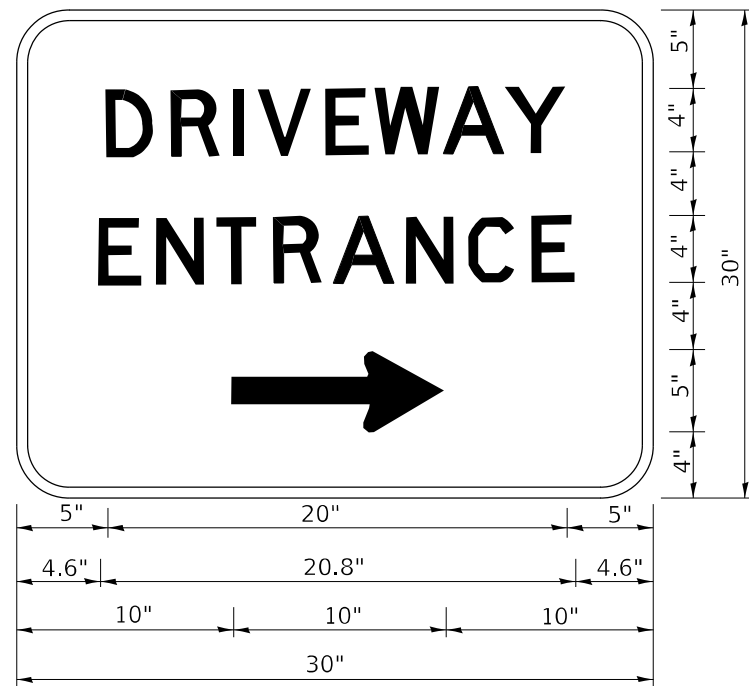

3.0" RADIUS, 0.5" BORDER, WHITE ON GREEN; REFLECTORIZED
 "DRIVEWAY" D; "ENTRANCE" D; STANDARD ARROW CUSTOM 12.0" x 5.0"

NOTES:

1. HALF OF THE SIGNS WILL REQUIRE A LEFT HAND FACING ARROW.
2. TWO SIGNS SHALL BE USED AT EACH COMMERCIAL ENTRANCE PLACED BACK-TO-BACK: ONE WITH A RIGHT HAND ARROW (SHOWN) SHALL BE PLACED ON THE NEAR RIGHT SIDE THE DRIVEWAY AND ONE WITH A LEFT HAND ARROW SHALL BE PLACED ON THE FAR LEFT SIDE OF THE DRIVEWAY.
3. SIGNS TO BE PAID FOR AS ITEM "TEMPORARY INFORMATION SIGNING".

MODEL: Default
 FILE NAME: p:\data\mroom.dwg
 PROJECT: P171099\CD\DATA\Design\DRIVE.dgn

USER NAME = kalorm	DESIGNED -	REVISED - C. JUCIUS 02-15-07
	DRAWN -	REVISED -
PLOT SCALE = 100,0000' / in.	CHECKED -	REVISED -
PLOT DATE = 1/27/2021	DATE -	REVISED -

STATE OF ILLINOIS
 DEPARTMENT OF TRANSPORTATION

DRIVEWAY ENTRANCE SIGNING

SCALE: NONE SHEET 1 OF 2 SHEETS STA. TO STA.

F.A.P. RTE.	SECTION	COUNTY	TOTAL SHEETS	SHEET NO.
303	(134&134XIN	LAKE	129	107
TC-26			CONTRACT NO. 60V39	
ILLINOIS FED. AID PROJECT				

MODEL: Default
FILE NAME: p:\data\room.dwg
PROJECT: P:\171099\CADD\DATA\Design\171099-INT-DETAIL.dwg

USER NAME = kalorm	DESIGNED -	REVISED -
	DRAWN -	REVISED -
PLOT SCALE = 100,0000 ' / in.	CHECKED -	REVISED -
PLOT DATE = 1/27/2021	DATE -	REVISED -

**STATE OF ILLINOIS
DEPARTMENT OF TRANSPORTATION**

SCALE: SHEET 1 OF 1 SHEETS STA. TO STA.

F.A.P. RTE.	SECTION	COUNTY	TOTAL SHEETS	SHEET NO.
303	(134&134X)N	LAKE	129	108
				CONTRACT NO. 60V39
				ILLINOIS FED. AID PROJECT

Model: Default
FILE NAME: p:\data\room.dwg
PROJECT: P:\171099\CADD\DATA\Design\171099-INT-DETAIL.dwg

USER NAME = kalorm	DESIGNED -	REVISED -
	DRAWN -	REVISED -
PLOT SCALE = 100,0000 ' / in.	CHECKED -	REVISED -
PLOT DATE = 1/27/2021	DATE -	REVISED -

**STATE OF ILLINOIS
DEPARTMENT OF TRANSPORTATION**

SCALE: SHEET 1 OF 1 SHEETS STA. TO STA.

F.A.P. RTE.	SECTION	COUNTY	TOTAL SHEETS	SHEET NO.
303	(134&134X)N	LAKE	129	109
CONTRACT NO. 60V39				
ILLINOIS FED. AID PROJECT				

MODEL: Default
FILE NAME: p:\data\room.dwg
PROJECT: P:\171099\CADD\DATA\Design\171099-INT-60V39.dwg

USER NAME = kalorm	DESIGNED -	REVISED -
	DRAWN -	REVISED -
PLOT SCALE = 100,0000 ' / in.	CHECKED -	REVISED -
PLOT DATE = 1/27/2021	DATE -	REVISED -

**STATE OF ILLINOIS
DEPARTMENT OF TRANSPORTATION**

SCALE: SHEET 1 OF 1 SHEETS STA. TO STA.

F.A.P. RTE.	SECTION	COUNTY	TOTAL SHEETS	SHEET NO.
303	(134&134X)N	LAKE	129	110
				CONTRACT NO. 60V39
				ILLINOIS FED. AID PROJECT

ORIGINAL SURVEY	SURVEYED	BY	DATE
NOTE BOOK	PLOTTED		
	TEMPLATE		
	AREAS		
	CHECKED		

FINAL SURVEY	SURVEYED	BY	DATE
NOTE BOOK	PLOTTED		
	TEMPLATE		
	AREAS		
	CHECKED		

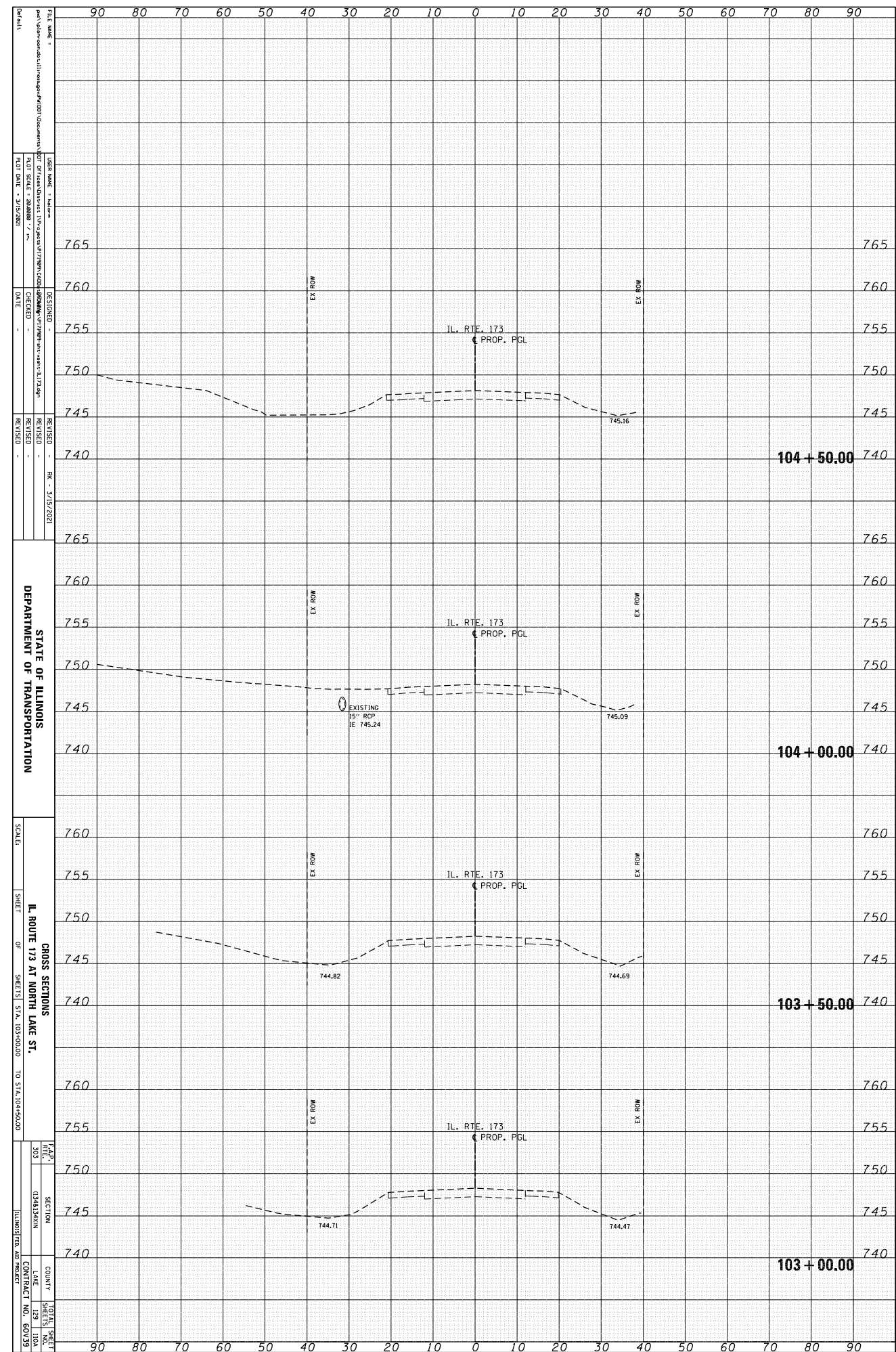

FILE NAME: ...
 USER NAME: ...
 DATE: ...
 DESIGNED: ...
 CHECKED: ...
 REVISION: ...
 DEPARTMENT OF TRANSPORTATION
 ILL. ROUTE 173 AT NORTH LAKE ST.
 CROSS SECTIONS
 SHEET OF SHEETS STA. 103+00.00 TO STA. 104+50.00
 COUNTY: ...
 CONTRACT NO.: 60V79

ORIGINAL SURVEY	SURVEYED	BY	DATE
NOTE BOOK	PLOTTED		
	TEMPLATE		
	AREA		
	AREAS CHECKED		

FINAL SURVEY	SURVEYED	BY	DATE
NOTE BOOK	PLOTTED		
	TEMPLATE		
	AREA		
	AREAS CHECKED		

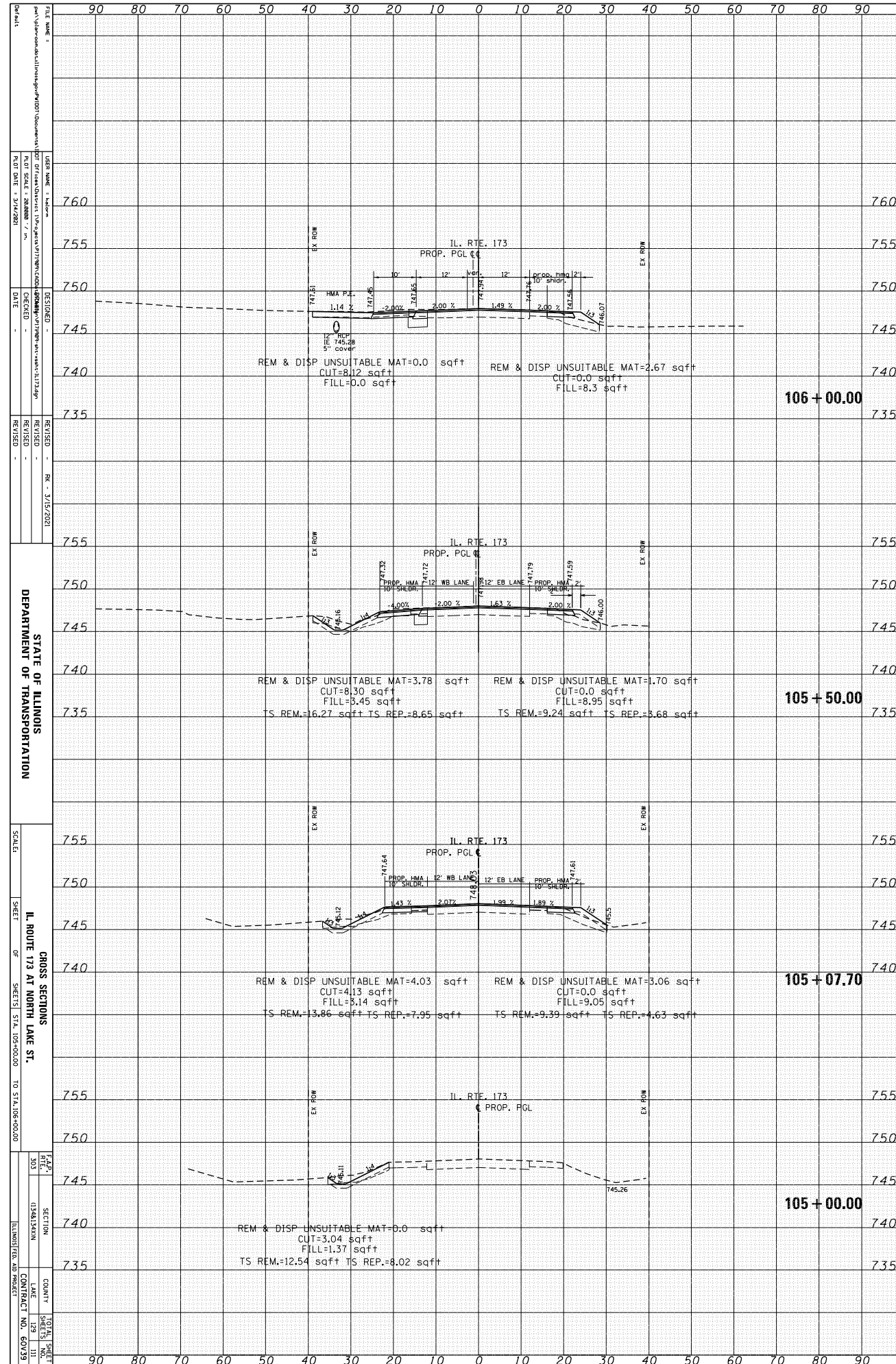

ORIGINAL SURVEY	SURVEYED	BY	DATE
NOTE BOOK	PLOTTED		
	TEMPLATE		
	AREA		
	AREAS CHECKED		

FINAL SURVEY	SURVEYED	BY	DATE
NOTE BOOK	PLOTTED		
	TEMPLATE		
	AREA		
	AREAS CHECKED		

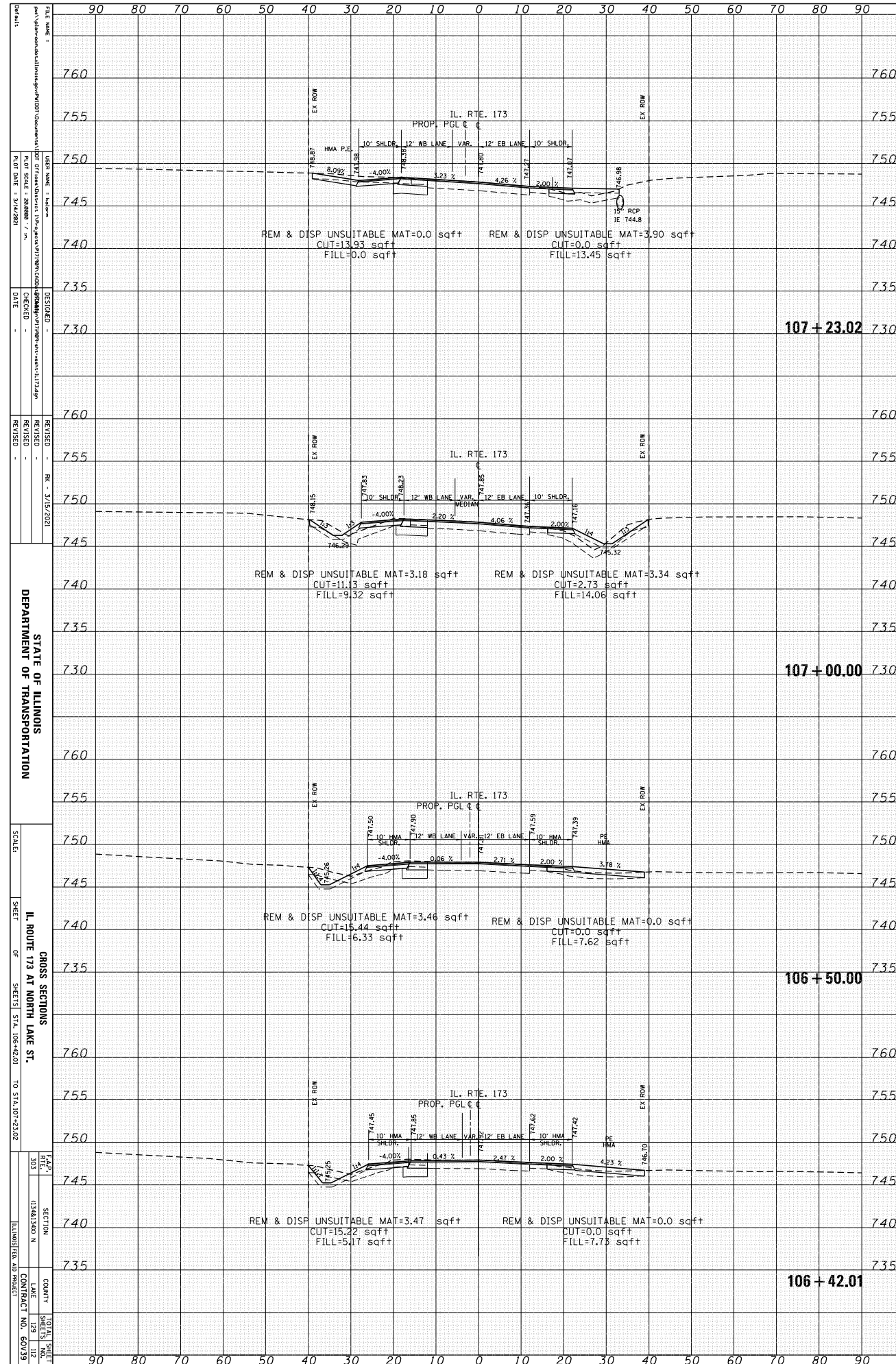

STATE OF ILLINOIS
 DEPARTMENT OF TRANSPORTATION

CROSS SECTIONS
 ILL. ROUTE 173 AT NORTH LAKE ST.
 OF SHEETS STA. 108+42.01 TO STA. 107+23.02

SECTION 033
 034191300 N
 COUNTY LAKE
 CONTRACT NO. 60V93

FILE NAME: I:\Projects\106+42.01\106+42.01.dwg
 USER: jk
 PLOT DATE: 3/14/2001
 DESIGNED: -
 CHECKED: -
 DATE: -

REVISION: -
 REVISION: -
 REVISION: -
 DATE: -

SCALE: -
 SHEET: -

SECTION: -
 SHEETS: -

SECTION: -
 SHEETS: -

COUNTY: LAKE
 CONTRACT NO.: 60V93

ORIGINAL SURVEY	SURVEYED	BY	DATE
NOTE BOOK	PLOTTED		
	TEMPLATE		
	AREAS CHECKED		
	AREAS CHECKED		

FINAL SURVEY	SURVEYED	BY	DATE
NOTE BOOK	PLOTTED		
	TEMPLATE		
	AREAS CHECKED		
	AREAS CHECKED		

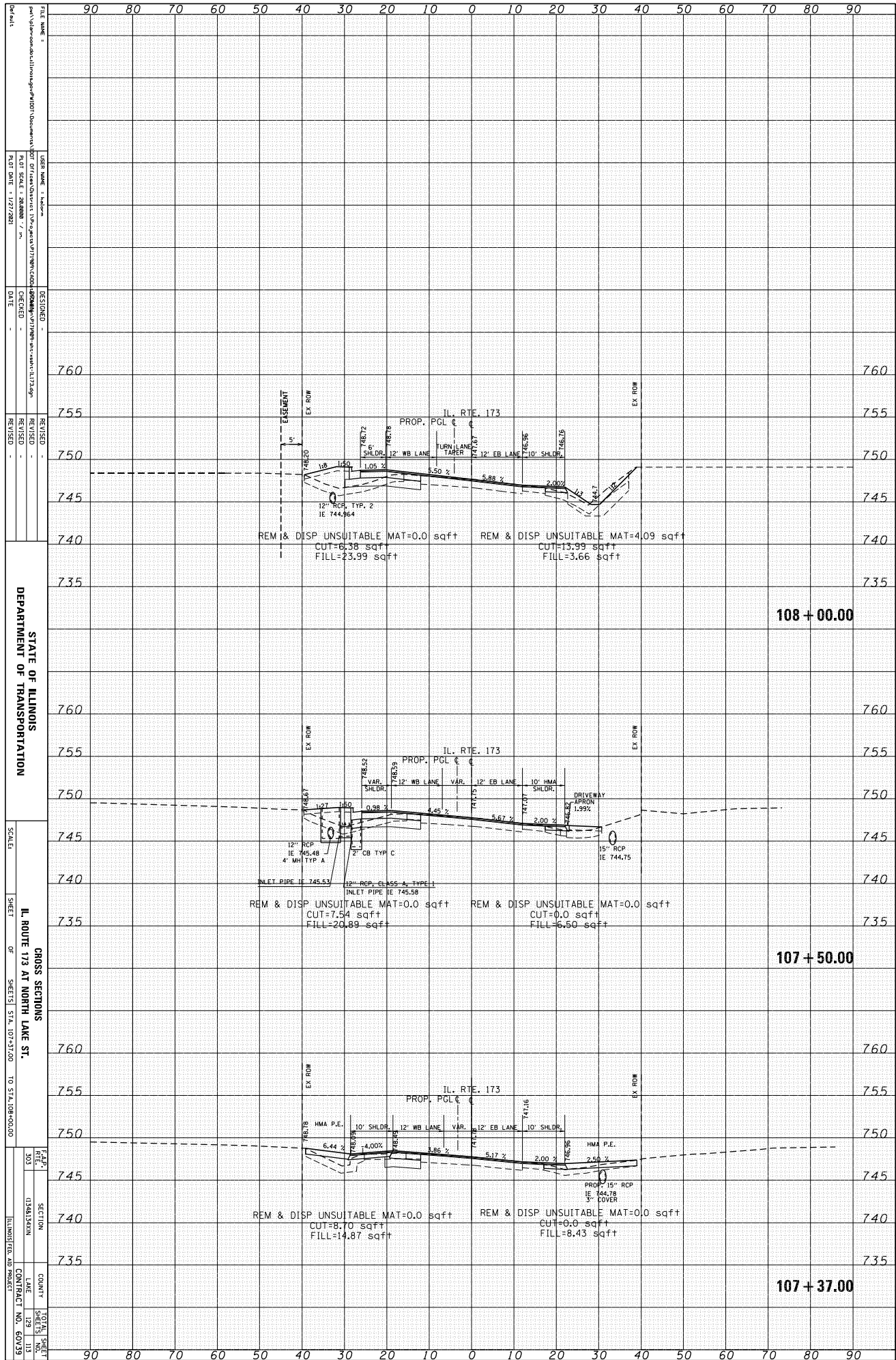

FILE NAME: I:\Projects\107+37.00\107+37.00.dwg
 USER NAME: J. Anderson
 DATE: 1/27/2006
 DESIGNED: -
 CHECKED: -
 REVISION: -

STATE OF ILLINOIS
 DEPARTMENT OF TRANSPORTATION

CROSS SECTIONS
 OF
 ILL. ROUTE 173 AT NORTH LAKE ST.
 FROM STA. 107+37.00 TO STA. 108+00.00

SCALE: 1" = 10'-0"
 SHEET: 107+37.00
 OF: 107+37.00 TO 108+00.00

SECTION: 107+37.00
 OF: 107+37.00 TO 108+00.00

COUNTY: ILLINOIS
 CONTRACT NO.: 60V93

ORIGINAL SURVEY	SURVEYED	BY	DATE
NOTE BOOK	PLOTTED		
	TEMPLATE		
	AREAS		
	CHECKED		

FINAL SURVEY	SURVEYED	BY	DATE
NOTE BOOK	PLOTTED		
	TEMPLATE		
	AREAS		
	CHECKED		

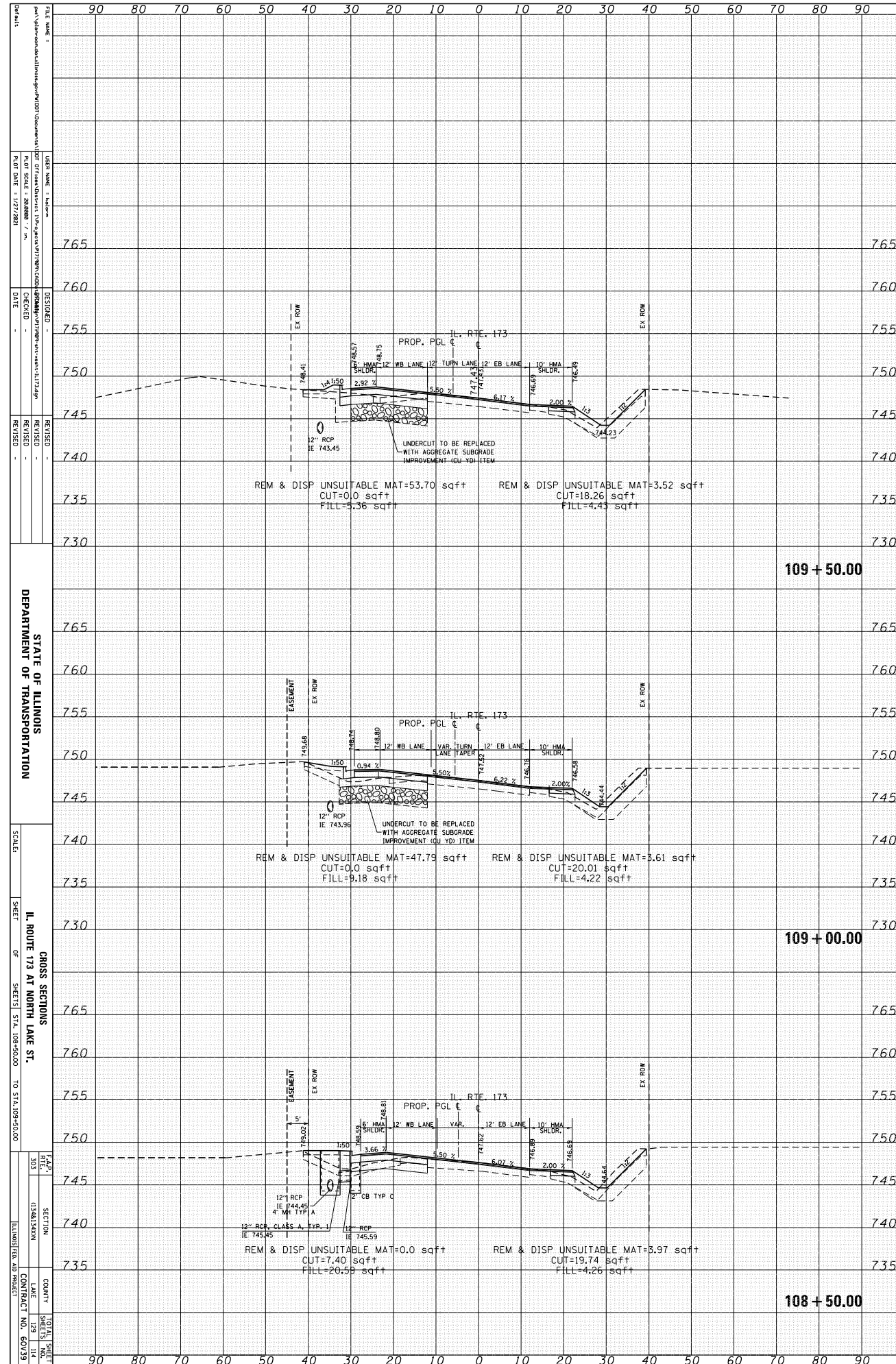

STATE OF ILLINOIS
 DEPARTMENT OF TRANSPORTATION

SCALE: _____
 SHEET _____ OF _____ SHEETS
 STA. 108+50.00 TO STA. 109+50.00

COUNTY _____
 LAKE _____
 CONTRACT NO. 60V93

FILE NAME: _____
 USER NAME: _____
 PLOT DATE: 1/27/2001
 DESIGNED: _____
 CHECKED: _____
 DATE: _____
 REVISION: _____

PROJECT: _____
 DRAWING NO.: _____
 SHEET NO.: _____

ORIGINAL SURVEY	SURVEYED	BY	DATE
NOTE BOOK	PLOTTED		
	TEMPLATE		
	AREA		
	CHECKED		

FINAL SURVEY	SURVEYED	BY	DATE
NOTE BOOK	PLOTTED		
	TEMPLATE		
	AREA		
	CHECKED		

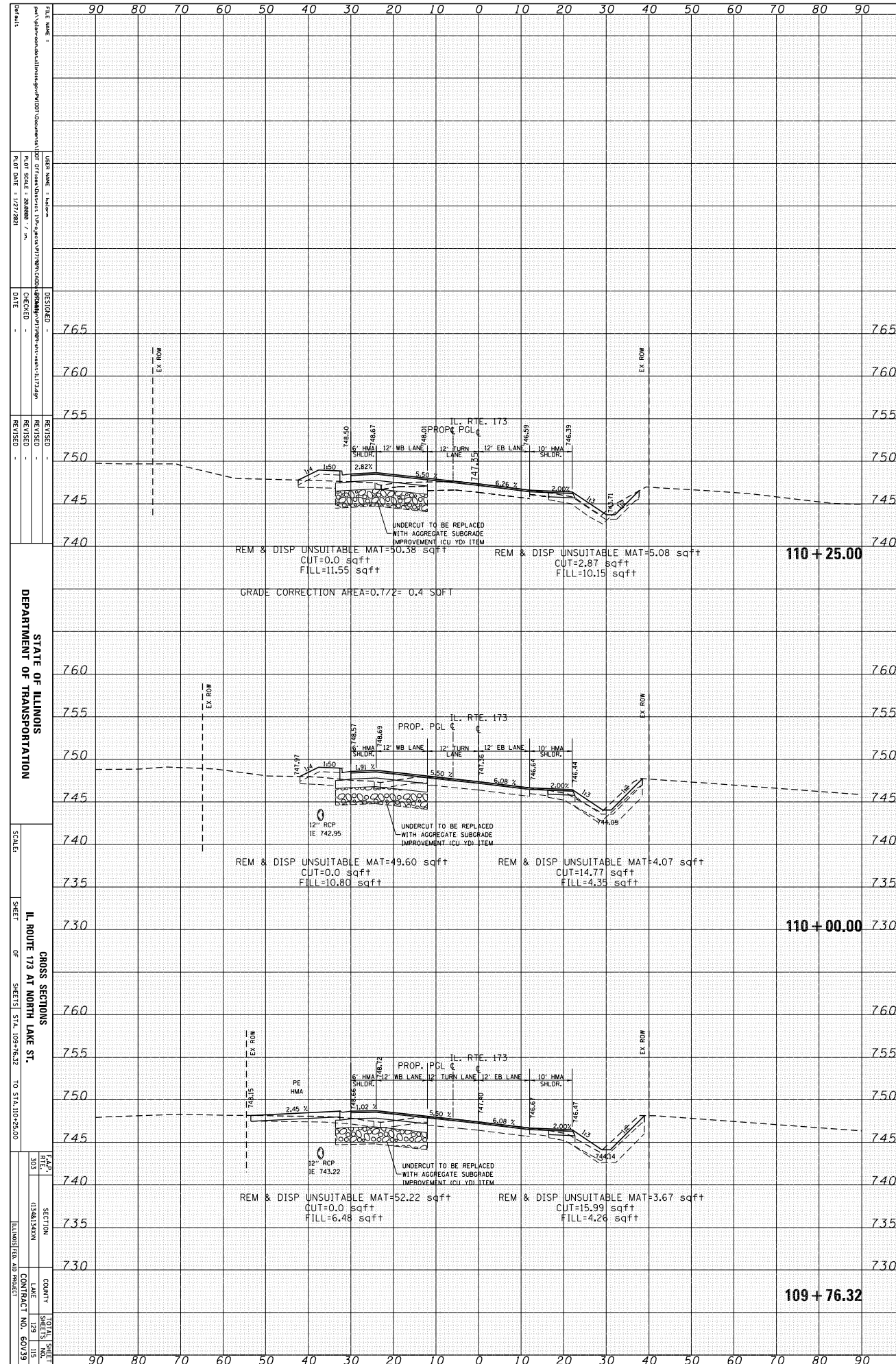

ORIGINAL SURVEY	SURVEYED BY	DATE
NOTE BOOK	PLOTTED TEMPLATE	
NO.	AREAS CHECKED	

FINAL SURVEY	SURVEYED BY	DATE
NOTE BOOK	PLOTTED TEMPLATE	
NO.	AREAS CHECKED	

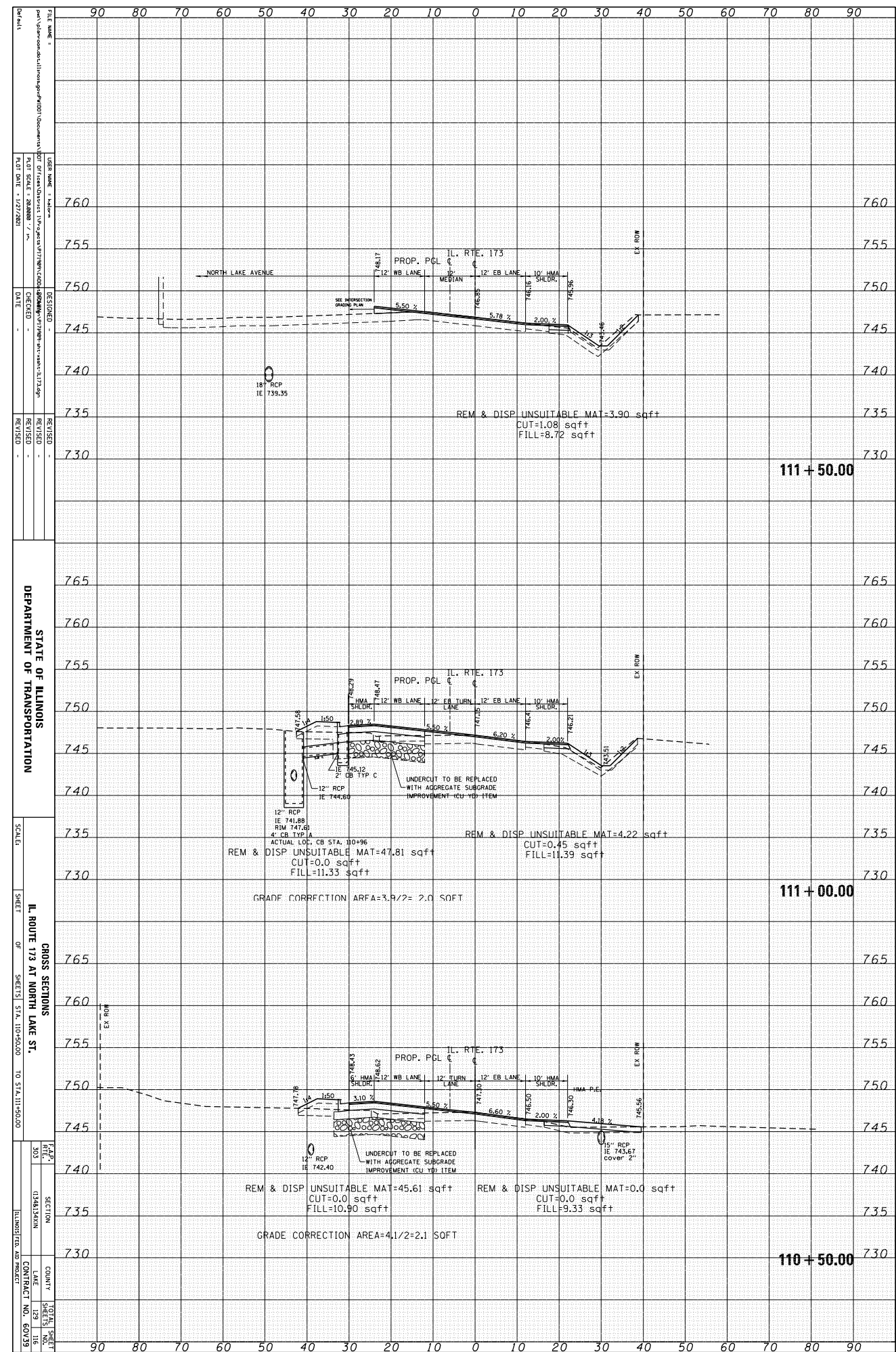

FILE NAME: I:\Projects\110+00\110+00.dwg
 USER NAME: J. Anderson
 PLOT DATE: 1/27/2001
 DESIGNED: -
 CHECKED: -
 DATE: -
 REVISION: -
 REVISION: -
 REVISION: -

STATE OF ILLINOIS
 DEPARTMENT OF TRANSPORTATION

SCALE: -
 SHEET: ILL. ROUTE 173 AT NORTH LAKE ST.
 OF SHEETS: STA. 110+50.00 TO STA. 111+50.00

CROSS SECTIONS
 DATE: 1/27/01
 DRAWN: J. Anderson
 COUNTY: LAKE
 CONTRACT NO.: 60V93

ORIGINAL SURVEY	SURVEYED	BY	DATE
NOTE BOOK	PLOTTED		
	TEMPLATE		
	PRINTED		
	AREAS CHECKED		

FINAL SURVEY	SURVEYED	BY	DATE
NOTE BOOK	PLOTTED		
	TEMPLATE		
	PRINTED		
	AREAS CHECKED		

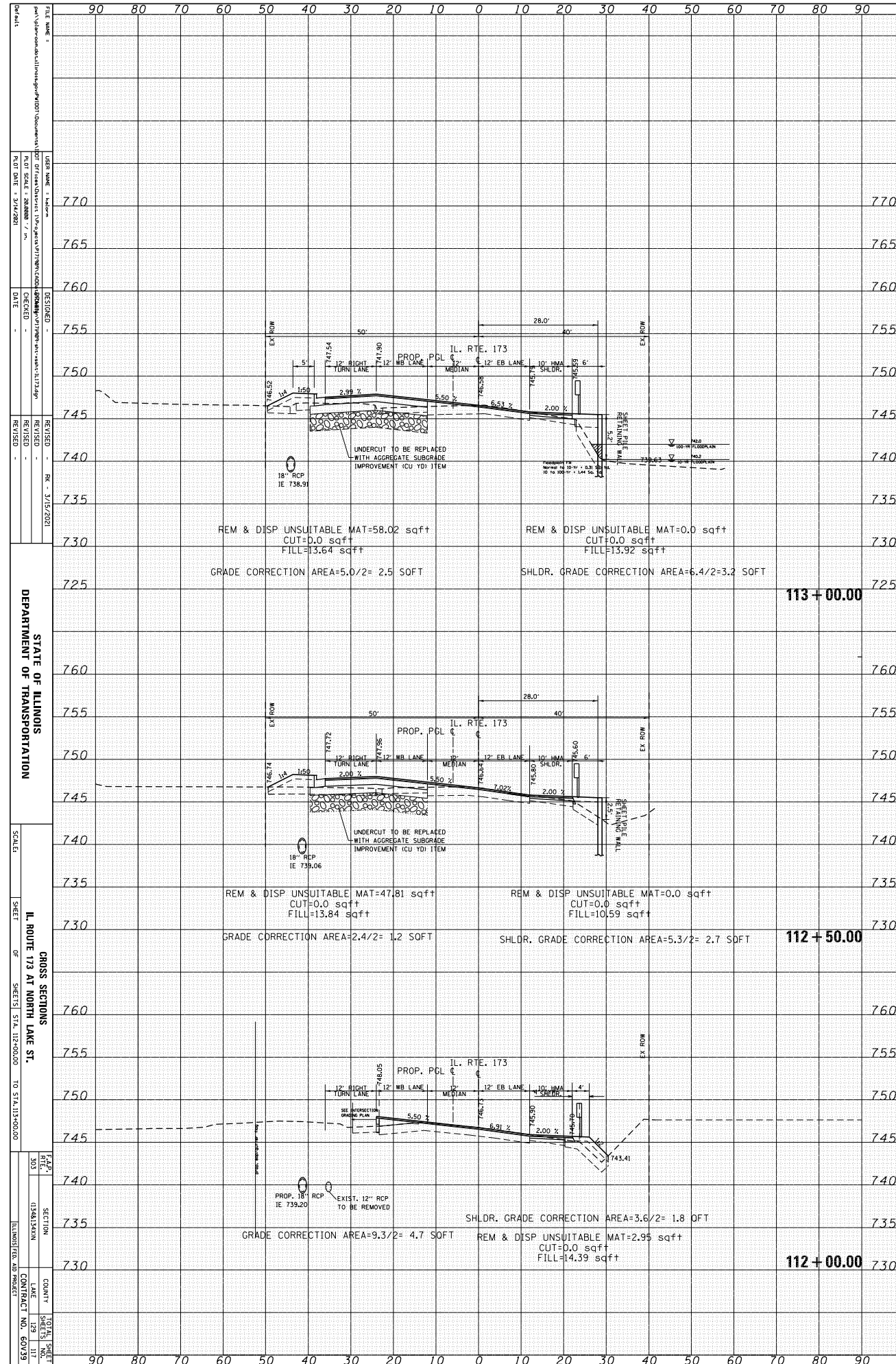

FILE NAME: I:\Projects\112+00.00\112+00.00.dwg
 USER NAME: J. Anderson
 DATE OF SCALE: 3/14/2001
 DESIGNED: -
 CHECKED: -
 DATE: -
 REVISION: -
 REVISION: -
 REVISION: -
 DATE: -
 DATE: -
 DATE: -

STATE OF ILLINOIS
 DEPARTMENT OF TRANSPORTATION

SCALE: 1"=40'
 SHEET 112+00.00
 OF 112+00.00 TO 112+50.00

CROSS SECTIONS
 ILL. ROUTE 173 AT NORTH LAKE ST.

SECTION 112+00.00
 COUNTY: COOK
 LAKE: LAKE MICHIGAN
 CONTRACT NO. 60V93

ORIGINAL SURVEY	SURVEYED	BY	DATE
NOTE BOOK	PLOTTED		
	TEMPLATE		
	AREA		
	AREAS CHECKED		

FINAL SURVEY	SURVEYED	BY	DATE
NOTE BOOK	PLOTTED		
	TEMPLATE		
	AREA		
	AREAS CHECKED		

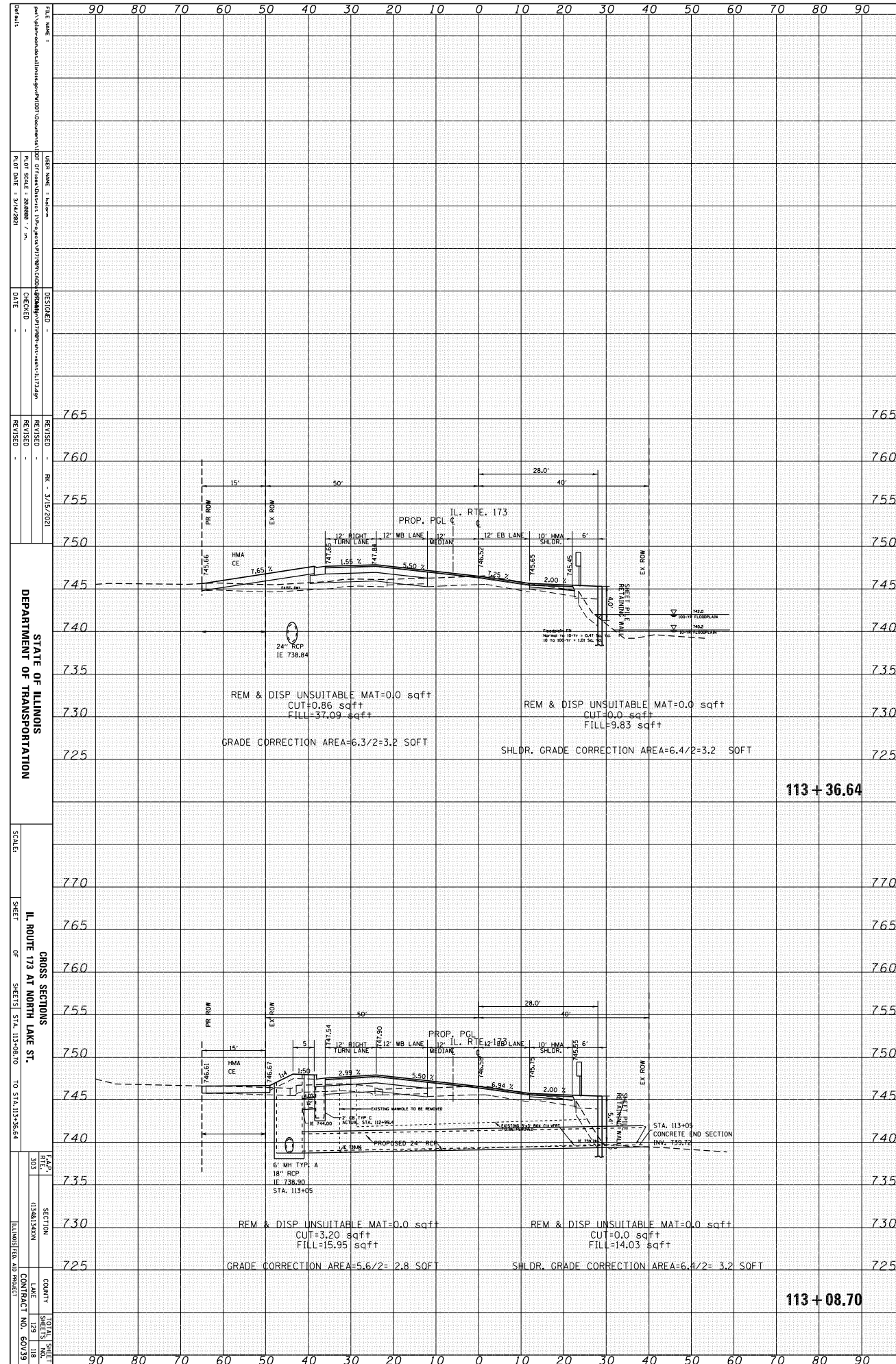

FILE NAME: I:\Projects\113+08.70\113+08.70.dwg
 USER NAME: J. Anderson
 DATE OF SCALE: 2/14/2007
 DATE: 2/14/2007
 DESIGNED: J. Anderson
 CHECKED: J. Anderson
 REVISIONS:
 NO. DESCRIPTION
 1. R1 - 3/15/2007

SCALE: 1"=40'
 SHEET 3 OF 3
 COUNTY: ILLINOIS
 LAKE: LAKE
 CONTRACT NO. 60V93



ORIGINAL SURVEY	SURVEYED	BY	DATE
NOTE BOOK	PLOTTED		
	TEMPLATE		
	AREAS		
	CHECKED		

FINAL SURVEY	SURVEYED	BY	DATE
NOTE BOOK	PLOTTED		
	TEMPLATE		
	AREAS		
	CHECKED		

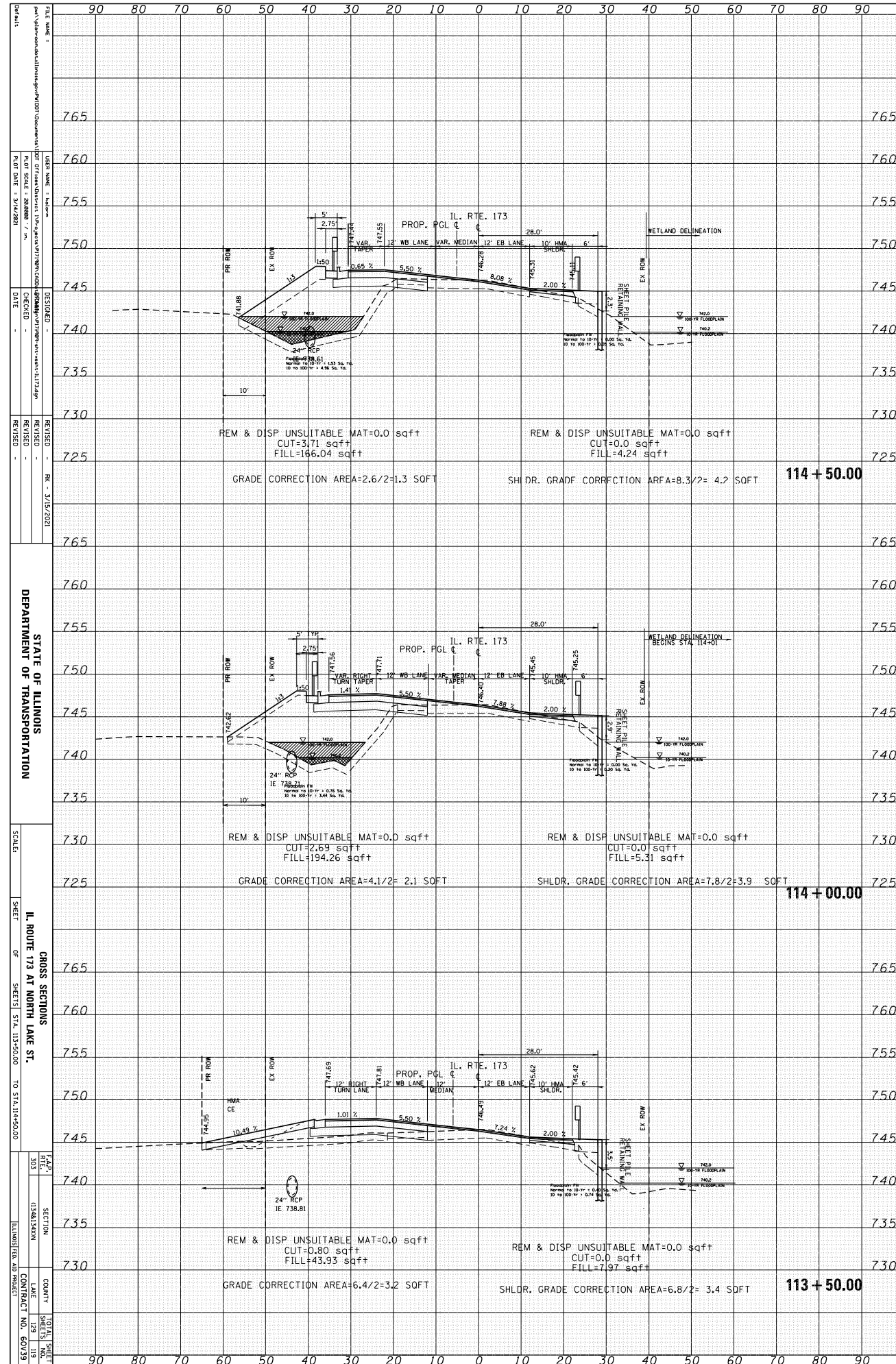

FILE NAME: I:\Projects\113+50.00\113+50.00.dwg
 DESIGNED: [Name]
 CHECKED: [Name]
 DATE: [Date]

DESIGNED: [Name]
 CHECKED: [Name]
 DATE: [Date]

DESIGNED: [Name]
 CHECKED: [Name]
 DATE: [Date]

STATE OF ILLINOIS
 DEPARTMENT OF TRANSPORTATION

CROSS SECTIONS
 OF
 ILL. ROUTE 173 AT NORTH LAKE ST.
 SHTS. STA. 113+50.00 TO STA. 114+50.00

COUNTY: [Name]
 LAKE: [Name]
 CONTRACT NO.: [Number]

ORIGINAL SURVEY	BY	DATE
SURVEYED		
PLOTTED		
NOTE BOOK		
AREAS CHECKED		
NO.		

FINAL SURVEY	BY	DATE
SURVEYED		
PLOTTED		
NOTE BOOK		
AREAS CHECKED		
NO.		

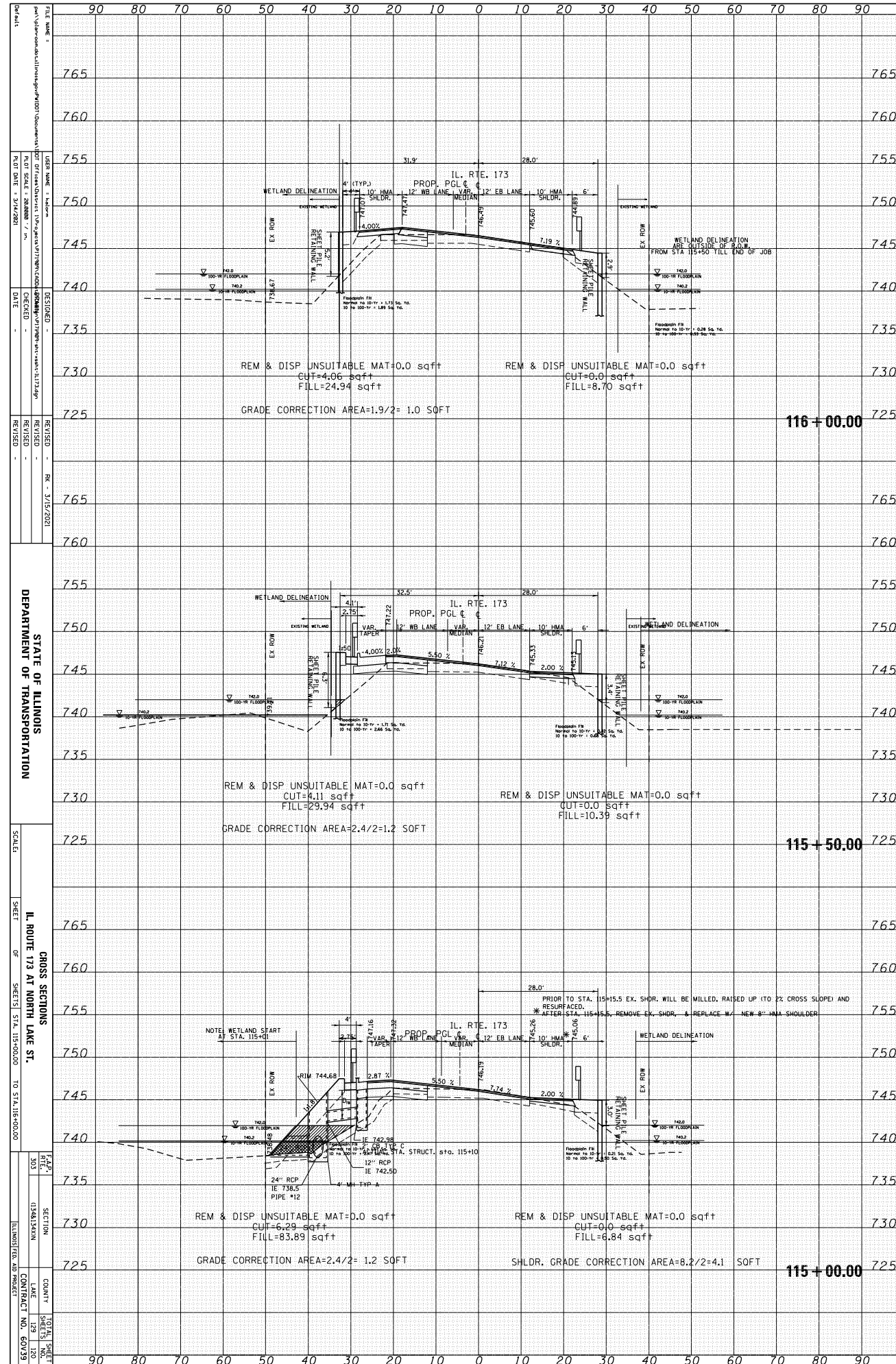

FILE NAME: I:\Projects\115+00.00\115+00.00.dwg
 DESIGNED: [Name]
 CHECKED: [Name]
 DATE: [Date]
 REVISIONS: [List]
 SCALE: [Scale]
 SHEET: [Number]
 CROSS SECTIONS: [List]
 COUNTY: [County]
 LANE: [Lane]
 CONTRACT NO.: [Contract No.]

STATE OF ILLINOIS
 DEPARTMENT OF TRANSPORTATION

ILL. ROUTE 173 AT NORTH LAKE ST.

SECTION: [Section]
 COUNTY: [County]
 LANE: [Lane]
 CONTRACT NO.: [Contract No.]

ORIGINAL SURVEY	SURVEYED	BY	DATE
NOTE BOOK	PLOTTED		
	TEMPLATE		
	AREA		
	AREAS CHECKED		

FINAL SURVEY	SURVEYED	BY	DATE
NOTE BOOK	PLOTTED		
	TEMPLATE		
	AREA		
	AREAS CHECKED		

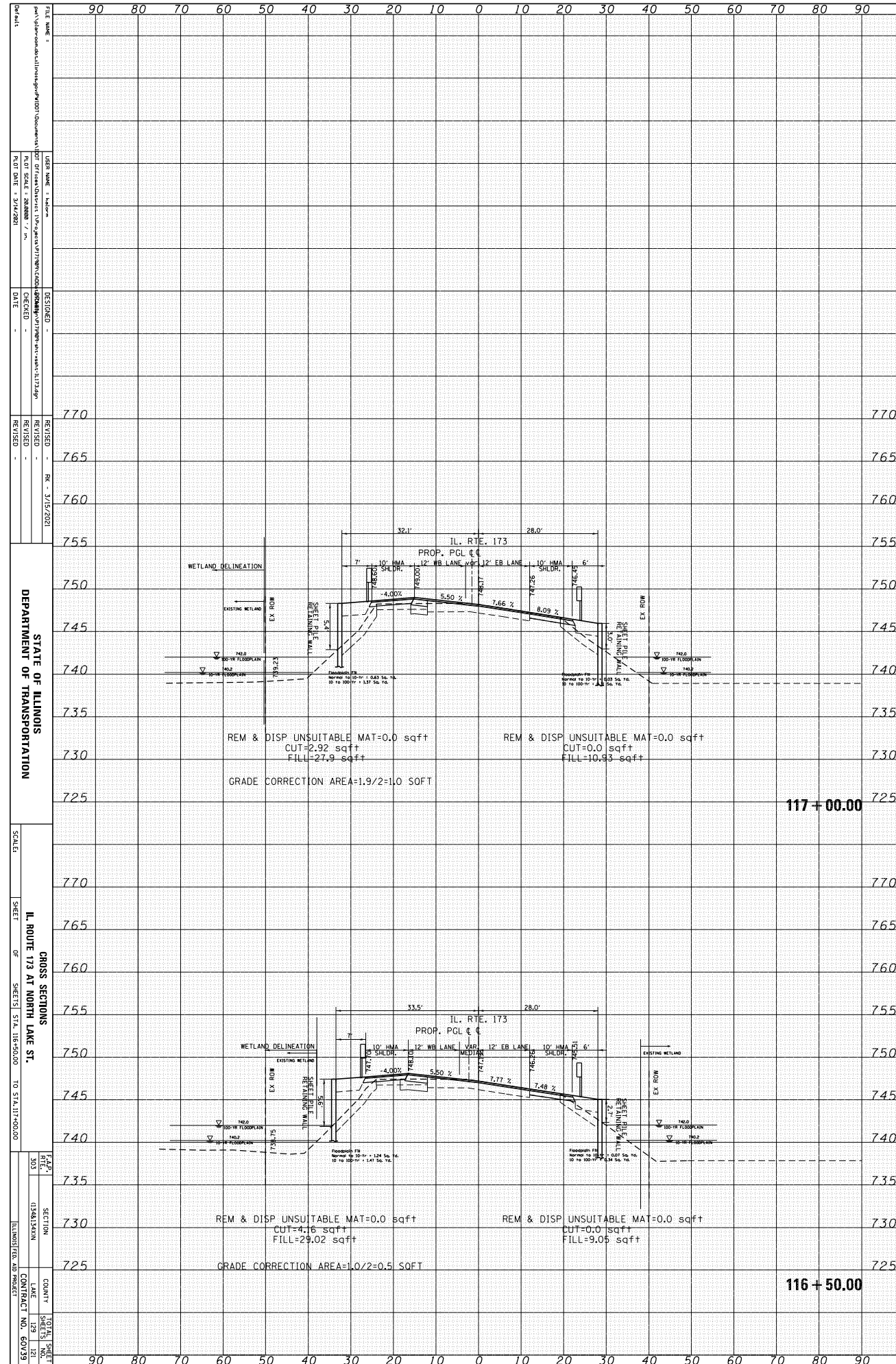

FILE NAME: I:\Projects\116+50.00\116+50.00.dwg
DESIGNED: [Signature]
DATE: 3/15/2021

DESIGNED: [Signature]
DATE: 3/15/2021

REVISIONS:

NO.	DATE	DESCRIPTION
1		ISSUED FOR PERMITS
2		REVISED
3		REVISED
4		REVISED
5		REVISED
6		REVISED
7		REVISED
8		REVISED
9		REVISED
10		REVISED
11		REVISED
12		REVISED
13		REVISED
14		REVISED
15		REVISED
16		REVISED
17		REVISED
18		REVISED
19		REVISED
20		REVISED
21		REVISED
22		REVISED
23		REVISED
24		REVISED
25		REVISED
26		REVISED
27		REVISED
28		REVISED
29		REVISED
30		REVISED
31		REVISED
32		REVISED
33		REVISED
34		REVISED
35		REVISED
36		REVISED
37		REVISED
38		REVISED
39		REVISED
40		REVISED
41		REVISED
42		REVISED
43		REVISED
44		REVISED
45		REVISED
46		REVISED
47		REVISED
48		REVISED
49		REVISED
50		REVISED
51		REVISED
52		REVISED
53		REVISED
54		REVISED
55		REVISED
56		REVISED
57		REVISED
58		REVISED
59		REVISED
60		REVISED
61		REVISED
62		REVISED
63		REVISED
64		REVISED
65		REVISED
66		REVISED
67		REVISED
68		REVISED
69		REVISED
70		REVISED
71		REVISED
72		REVISED
73		REVISED
74		REVISED
75		REVISED
76		REVISED
77		REVISED
78		REVISED
79		REVISED
80		REVISED
81		REVISED
82		REVISED
83		REVISED
84		REVISED
85		REVISED
86		REVISED
87		REVISED
88		REVISED
89		REVISED
90		REVISED

DEPARTMENT OF TRANSPORTATION

CROSS SECTIONS
OF
ILL. ROUTE 173 AT NORTH LAKE ST.
SHEETS 57A, 116+50.00 TO 57A, 117+00.00

COUNTY: LAKE
SHEET NO.: 123
CONTRACT NO.: 60V79

ORIGINAL SURVEY	SURVEYED	BY	DATE
NOTE BOOK	PLOTTED		
	TEMPLATE		
	AREA		
	AREAS CHECKED		

FINAL SURVEY	SURVEYED	BY	DATE
NOTE BOOK	PLOTTED		
	TEMPLATE		
	AREA		
	AREAS CHECKED		

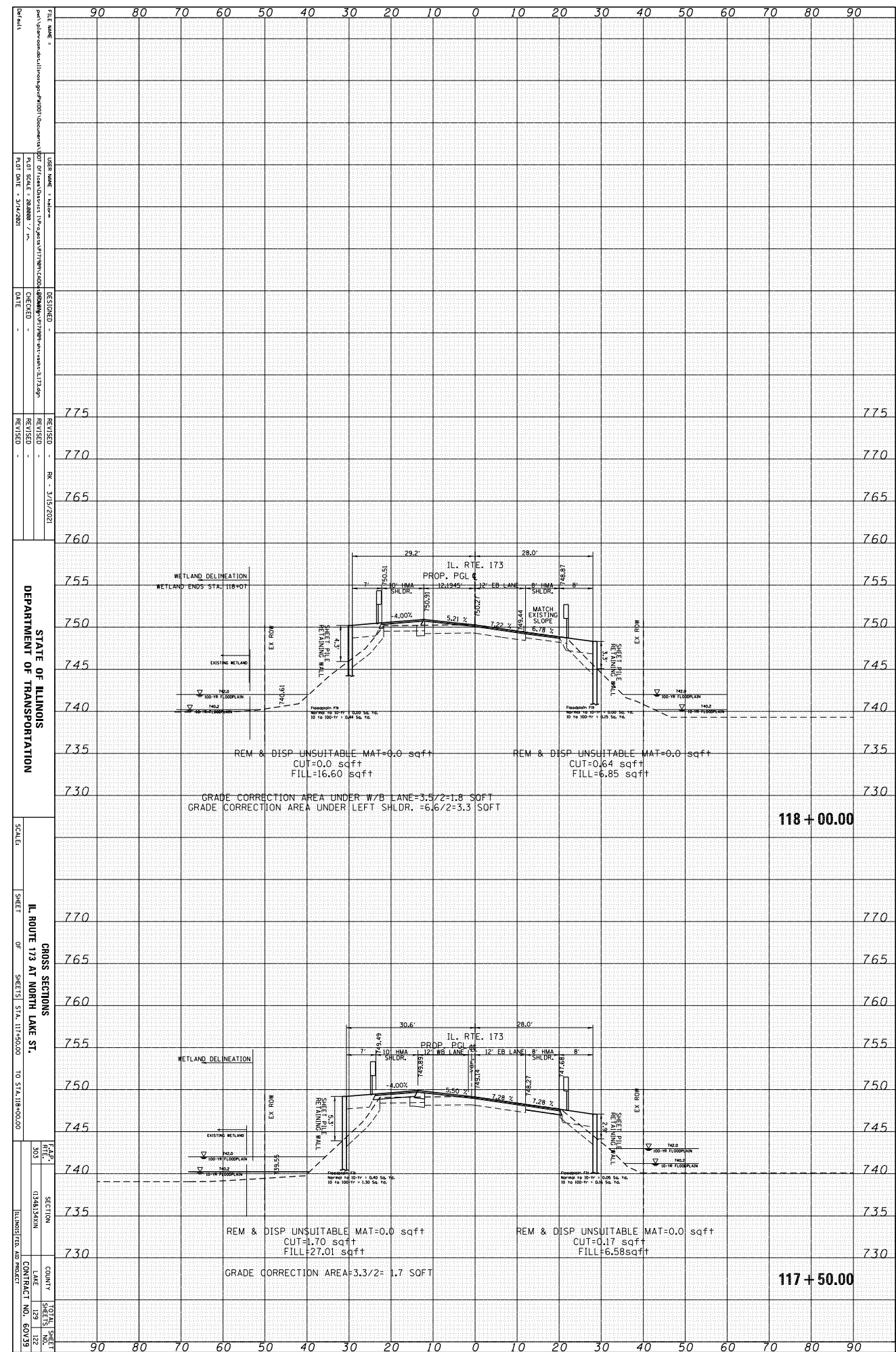

ORIGINAL SURVEY	SURVEYED	BY	DATE
NOTE BOOK	PLOTTED		
	TEMPLATE		
	AREA		
	AREAS CHECKED		

FINAL SURVEY	SURVEYED	BY	DATE
NOTE BOOK	PLOTTED		
	TEMPLATE		
	AREA		
	AREAS CHECKED		

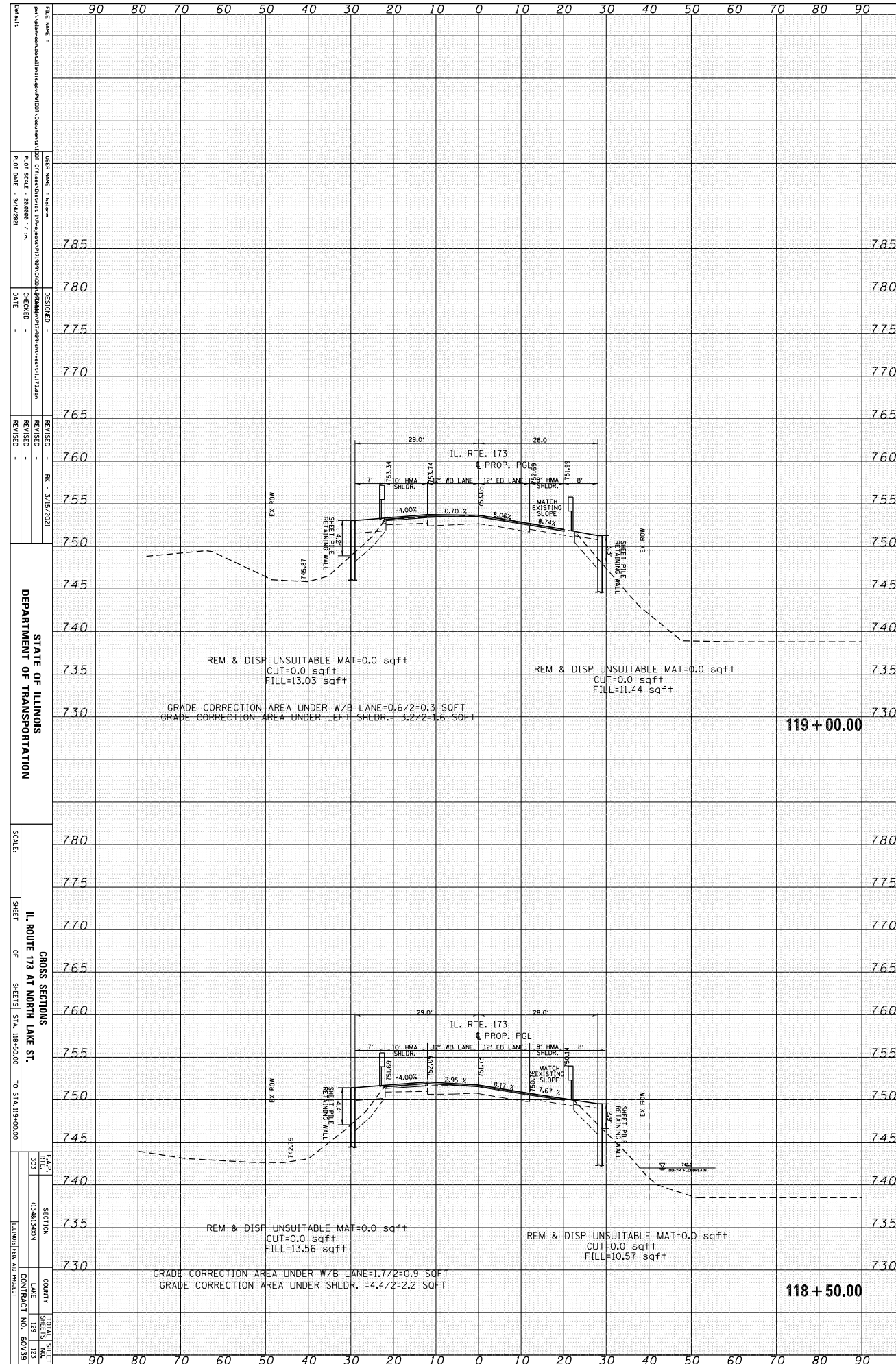

STATE OF ILLINOIS
DEPARTMENT OF TRANSPORTATION

CROSS SECTIONS
ILL. ROUTE 173 AT NORTH LAKE ST.
SHEET 303 OF 303 SHEETS STA. 118+50.00 TO STA. 119+00.00

SECTION 134613XN
COUNTY ILLINOIS
SHEET 303 OF 303 SHEETS
CONTRACT NO. 60V99

FILE NAME: I:\Projects\118+50.00-119+00.00\118+50.00-119+00.00.dwg
DESIGNED: [Name]
CHECKED: [Name]
DATE: [Date]

DESIGNED: [Name]
CHECKED: [Name]
DATE: [Date]

REVISIONS:
NO. DESCRIPTION DATE

REVISIONS:
NO. DESCRIPTION DATE

ORIGINAL SURVEY	SURVEYED	BY	DATE
NOTE BOOK	PLOTTED		
	TEMPLATE		
	AREA		
	AREAS CHECKED		

FINAL SURVEY	SURVEYED	BY	DATE
NOTE BOOK	PLOTTED		
	TEMPLATE		
	AREA		
	AREAS CHECKED		

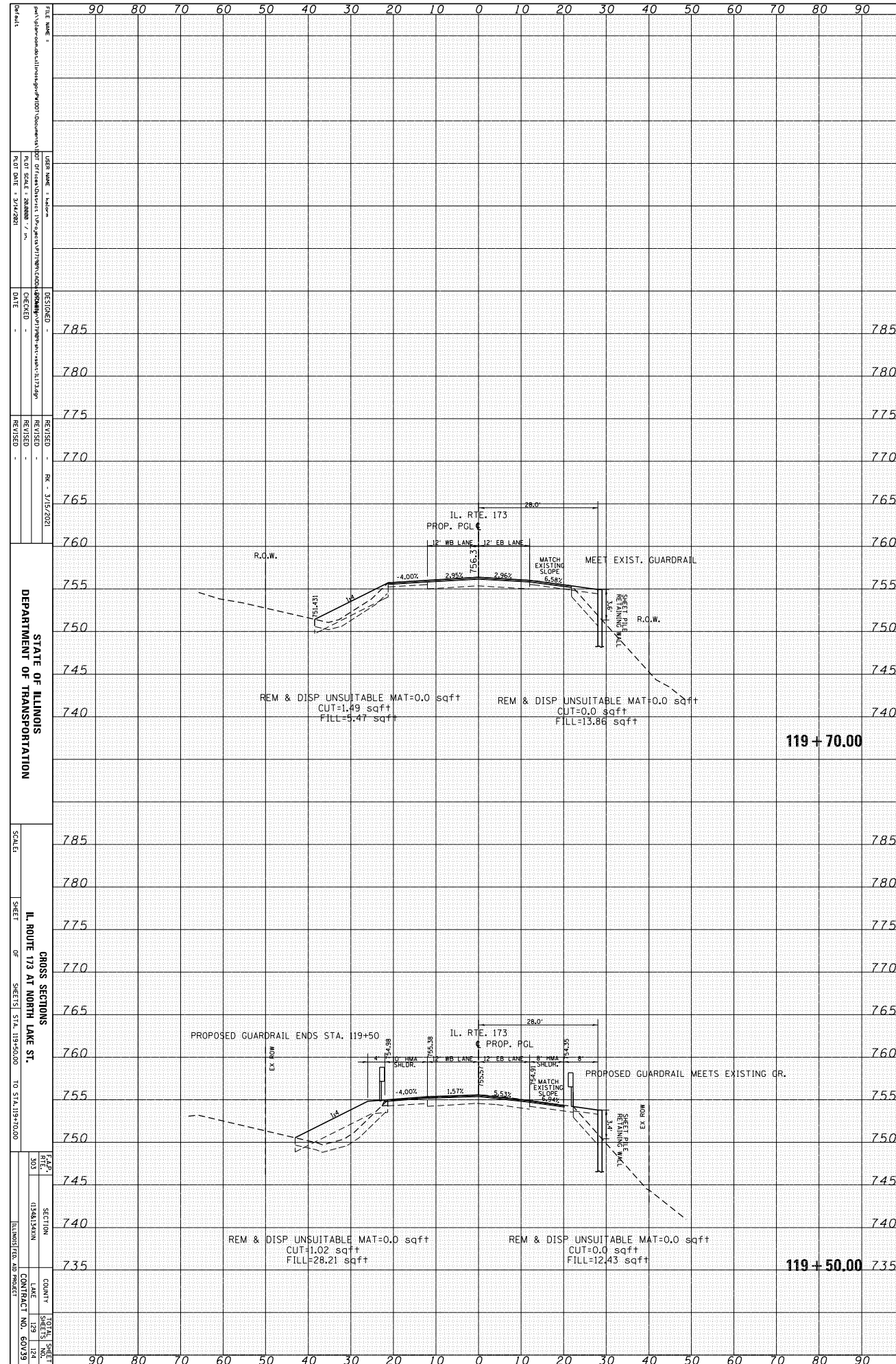

FILE NAME: I:\Projects\119+50\119+50.dwg
DESIGNED: RM - 3/15/2021
CHECKED: -
DATE: -
REVISION: -
REVISION: -
REVISION: -
REVISION: -

SCALE: SHEET 303 OF 303 SHEETS STA. 119+50.00 TO STA. 119+70.00

COUNTY: LAKE
SECTION: 134N134W
CONTRACT NO.: 60V99

ORIGINAL SURVEY	SURVEYED	BY	DATE
NOTE BOOK	PLOTTED		
	TEMPLATE		
	AREAS		
	CHECKED		

FINAL SURVEY	SURVEYED	BY	DATE
NOTE BOOK	PLOTTED		
	TEMPLATE		
	AREAS		
	CHECKED		

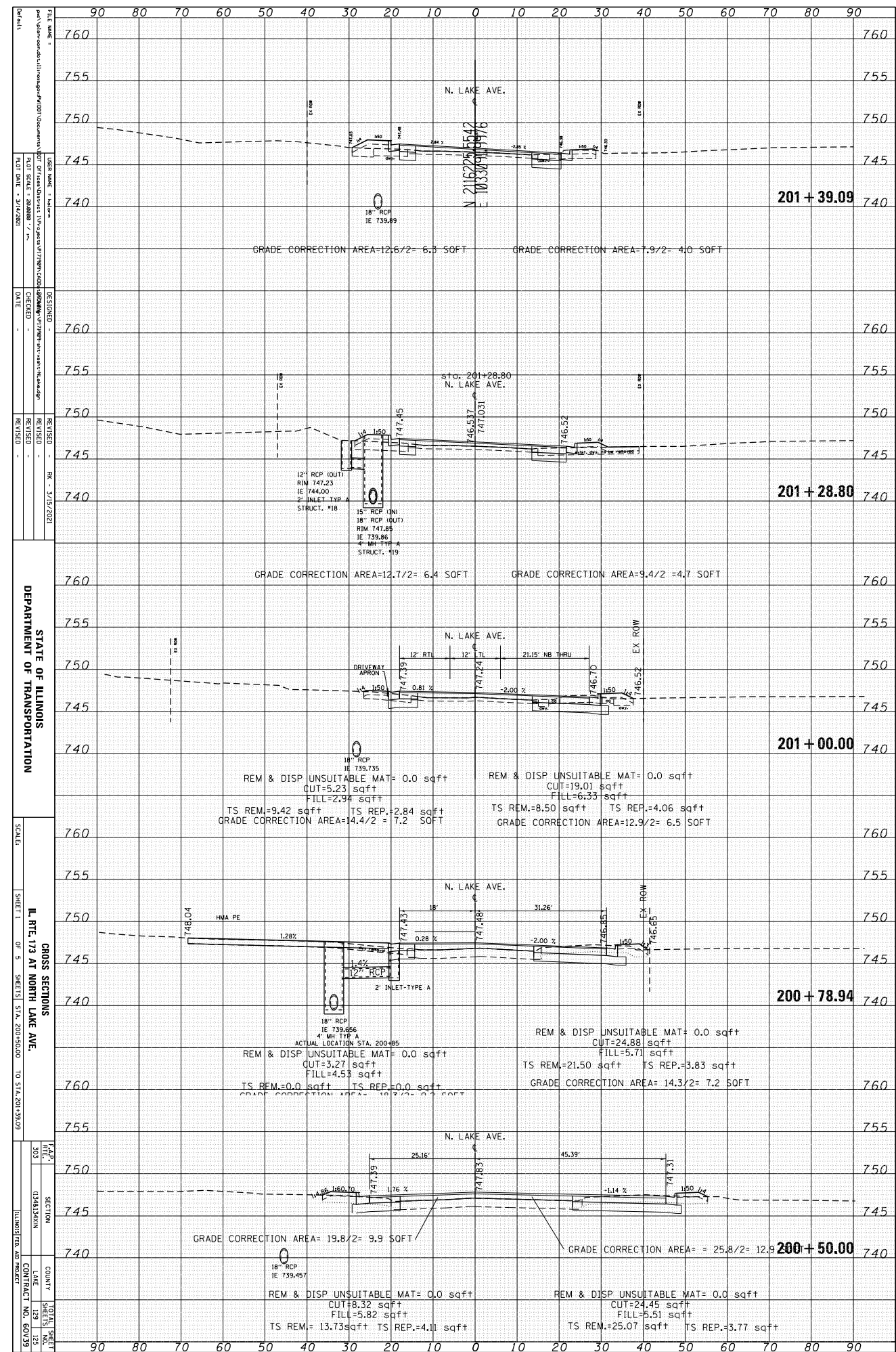

FILE NAME: I:\Projects\173\173_000\173_000.dwg
 DESIGNER: J. Anderson
 DATE: 3/15/2021
 CHECKED: -
 DATE: -
 REVISION: -
 DATE: -
 REVISION: -
 DATE: -

PROJECT: ILL. RTE. 173 AT NORTH LAKE AVE.
 SHEET: 5 OF 5
 COUNTY: LAKE
 CONTRACT NO: 60V99

DATE: 3/15/2021
 SCALE: 1" = 5' (VERTICAL), 1" = 20' (HORIZONTAL)
 SHEET: 5 OF 5
 COUNTY: LAKE
 CONTRACT NO: 60V99

DATE: 3/15/2021
 SCALE: 1" = 5' (VERTICAL), 1" = 20' (HORIZONTAL)
 SHEET: 5 OF 5
 COUNTY: LAKE
 CONTRACT NO: 60V99

DATE: 3/15/2021
 SCALE: 1" = 5' (VERTICAL), 1" = 20' (HORIZONTAL)
 SHEET: 5 OF 5
 COUNTY: LAKE
 CONTRACT NO: 60V99

DATE: 3/15/2021
 SCALE: 1" = 5' (VERTICAL), 1" = 20' (HORIZONTAL)
 SHEET: 5 OF 5
 COUNTY: LAKE
 CONTRACT NO: 60V99

DATE: 3/15/2021
 SCALE: 1" = 5' (VERTICAL), 1" = 20' (HORIZONTAL)
 SHEET: 5 OF 5
 COUNTY: LAKE
 CONTRACT NO: 60V99

DATE: 3/15/2021
 SCALE: 1" = 5' (VERTICAL), 1" = 20' (HORIZONTAL)
 SHEET: 5 OF 5
 COUNTY: LAKE
 CONTRACT NO: 60V99

DATE: 3/15/2021
 SCALE: 1" = 5' (VERTICAL), 1" = 20' (HORIZONTAL)
 SHEET: 5 OF 5
 COUNTY: LAKE
 CONTRACT NO: 60V99

DATE: 3/15/2021
 SCALE: 1" = 5' (VERTICAL), 1" = 20' (HORIZONTAL)
 SHEET: 5 OF 5
 COUNTY: LAKE
 CONTRACT NO: 60V99

DATE: 3/15/2021
 SCALE: 1" = 5' (VERTICAL), 1" = 20' (HORIZONTAL)
 SHEET: 5 OF 5
 COUNTY: LAKE
 CONTRACT NO: 60V99

DATE: 3/15/2021
 SCALE: 1" = 5' (VERTICAL), 1" = 20' (HORIZONTAL)
 SHEET: 5 OF 5
 COUNTY: LAKE
 CONTRACT NO: 60V99

DATE: 3/15/2021
 SCALE: 1" = 5' (VERTICAL), 1" = 20' (HORIZONTAL)
 SHEET: 5 OF 5
 COUNTY: LAKE
 CONTRACT NO: 60V99

DATE: 3/15/2021
 SCALE: 1" = 5' (VERTICAL), 1" = 20' (HORIZONTAL)
 SHEET: 5 OF 5
 COUNTY: LAKE
 CONTRACT NO: 60V99

DATE: 3/15/2021
 SCALE: 1" = 5' (VERTICAL), 1" = 20' (HORIZONTAL)
 SHEET: 5 OF 5
 COUNTY: LAKE
 CONTRACT NO: 60V99

DATE: 3/15/2021
 SCALE: 1" = 5' (VERTICAL), 1" = 20' (HORIZONTAL)
 SHEET: 5 OF 5
 COUNTY: LAKE
 CONTRACT NO: 60V99

DATE: 3/15/2021
 SCALE: 1" = 5' (VERTICAL), 1" = 20' (HORIZONTAL)
 SHEET: 5 OF 5
 COUNTY: LAKE
 CONTRACT NO: 60V99

DATE: 3/15/2021
 SCALE: 1" = 5' (VERTICAL), 1" = 20' (HORIZONTAL)
 SHEET: 5 OF 5
 COUNTY: LAKE
 CONTRACT NO: 60V99

DATE: 3/15/2021
 SCALE: 1" = 5' (VERTICAL), 1" = 20' (HORIZONTAL)
 SHEET: 5 OF 5
 COUNTY: LAKE
 CONTRACT NO: 60V99

DATE: 3/15/2021
 SCALE: 1" = 5' (VERTICAL), 1" = 20' (HORIZONTAL)
 SHEET: 5 OF 5
 COUNTY: LAKE
 CONTRACT NO: 60V99

DATE: 3/15/2021
 SCALE: 1" = 5' (VERTICAL), 1" = 20' (HORIZONTAL)
 SHEET: 5 OF 5
 COUNTY: LAKE
 CONTRACT NO: 60V99

DATE: 3/15/2021
 SCALE: 1" = 5' (VERTICAL), 1" = 20' (HORIZONTAL)
 SHEET: 5 OF 5
 COUNTY: LAKE
 CONTRACT NO: 60V99

DATE: 3/15/2021
 SCALE: 1" = 5' (VERTICAL), 1" = 20' (HORIZONTAL)
 SHEET: 5 OF 5
 COUNTY: LAKE
 CONTRACT NO: 60V99

DATE: 3/15/2021
 SCALE: 1" = 5' (VERTICAL), 1" = 20' (HORIZONTAL)
 SHEET: 5 OF 5
 COUNTY: LAKE
 CONTRACT NO: 60V99

DATE: 3/15/2021
 SCALE: 1" = 5' (VERTICAL), 1" = 20' (HORIZONTAL)
 SHEET: 5 OF 5
 COUNTY: LAKE
 CONTRACT NO: 60V99

DATE: 3/15/2021
 SCALE: 1" = 5' (VERTICAL), 1" = 20' (HORIZONTAL)
 SHEET: 5 OF 5
 COUNTY: LAKE
 CONTRACT NO: 60V99

DATE: 3/15/2021
 SCALE: 1" = 5' (VERTICAL), 1" = 20' (HORIZONTAL)
 SHEET: 5 OF 5
 COUNTY: LAKE
 CONTRACT NO: 60V99

DATE: 3/15/2021
 SCALE: 1" = 5' (VERTICAL), 1" = 20' (HORIZONTAL)
 SHEET: 5 OF 5
 COUNTY: LAKE
 CONTRACT NO: 60V99

DATE: 3/15/2021
 SCALE: 1" = 5' (VERTICAL), 1" = 20' (HORIZONTAL)
 SHEET: 5 OF 5
 COUNTY: LAKE
 CONTRACT NO: 60V99

DATE: 3/15/2021
 SCALE: 1" = 5' (VERTICAL), 1" = 20' (HORIZONTAL)
 SHEET: 5 OF 5
 COUNTY: LAKE
 CONTRACT NO: 60V99

DATE: 3/15/2021
 SCALE: 1" = 5' (VERTICAL), 1" = 20' (HORIZONTAL)
 SHEET: 5 OF 5
 COUNTY: LAKE
 CONTRACT NO: 60V99

DATE: 3/15/2021
 SCALE: 1" = 5' (VERTICAL), 1" = 20' (HORIZONTAL)
 SHEET: 5 OF 5
 COUNTY: LAKE
 CONTRACT NO: 60V99

DATE: 3/15/2021
 SCALE: 1" = 5' (VERTICAL), 1" = 20' (HORIZONTAL)
 SHEET: 5 OF 5
 COUNTY: LAKE
 CONTRACT NO: 60V99

DATE: 3/15/2021
 SCALE: 1" = 5' (VERTICAL), 1" = 20' (HORIZONTAL)
 SHEET: 5 OF 5
 COUNTY: LAKE
 CONTRACT NO: 60V99

DATE: 3/15/2021
 SCALE: 1" = 5' (VERTICAL), 1" = 20' (HORIZONTAL)
 SHEET: 5 OF 5
 COUNTY: LAKE
 CONTRACT NO: 60V99

ORIGINAL SURVEY	SURVEYED	BY	DATE
NOTE BOOK	PLOTTED		
	TEMPLATE		
	PRINT		
	AREAS CHECKED		

FINAL SURVEY	SURVEYED	BY	DATE
NOTE BOOK	PLOTTED		
	TEMPLATE		
	PRINT		
	AREAS CHECKED		

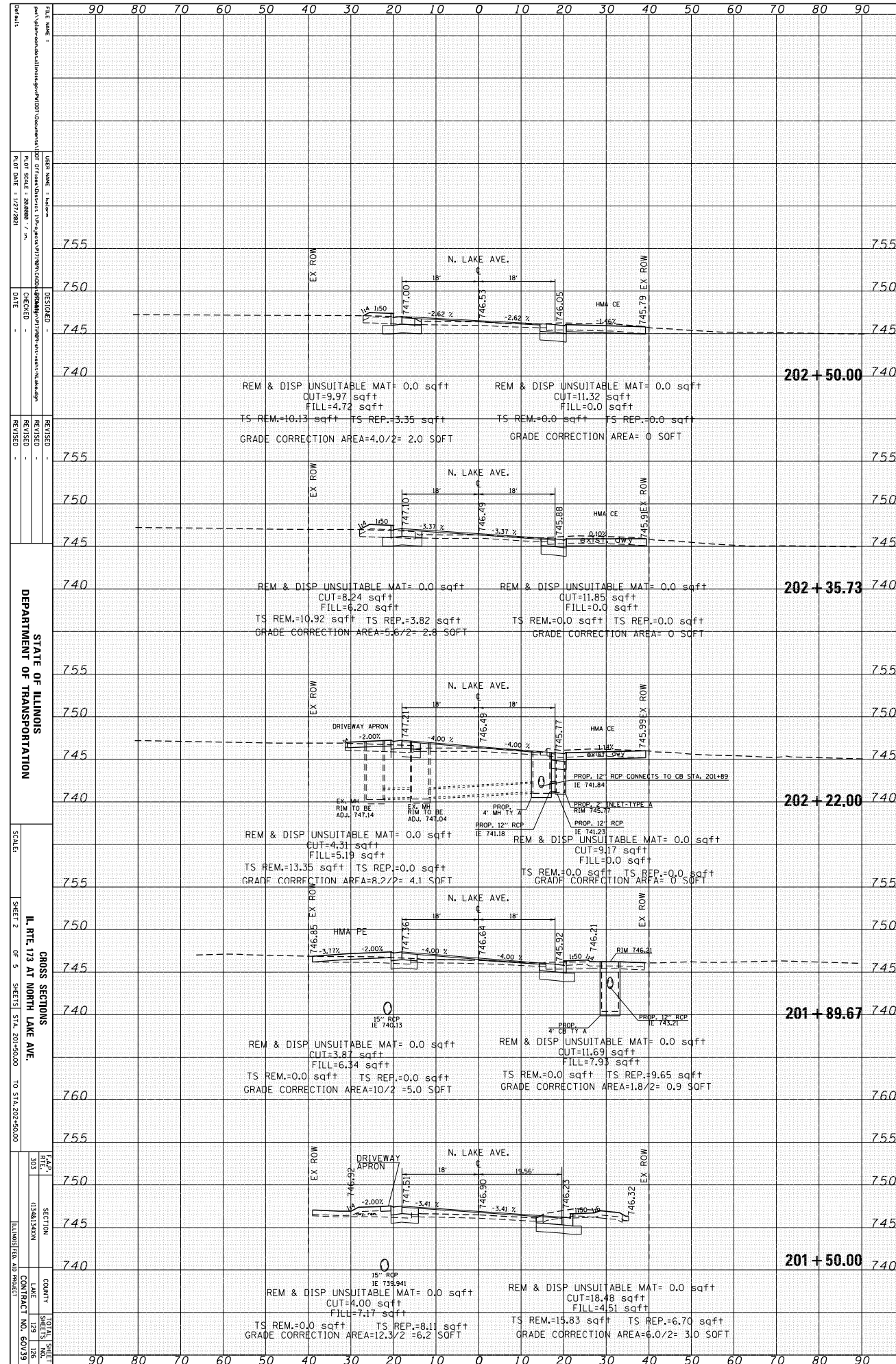

FILE NAME: I:\Projects\2011\1101\1101\1101.dwg
 USER NAME: J. Johnson
 PLOT DATE: 1/27/2011
 DESIGNED: -
 CHECKED: -
 DATE: -
 REVISION: -
 REVISION: -
 REVISION: -
 SCALE: 1"=40'-0"
 SHEET 2 OF 5 SHEETS STA. 201+50.00 TO STA. 202+50.00
 SECTION: 134A134XN
 COUNTY: LAKE
 CONTRACT NO. 60V93

STATE OF ILLINOIS
 DEPARTMENT OF TRANSPORTATION

CROSS SECTIONS
 ILL. RTE. 173 AT NORTH LAKE AVE.

DATE: 1/27/2011
 SHEET: 2 OF 5
 COUNTY: LAKE
 CONTRACT NO. 60V93

ORIGINAL SURVEY	SURVEYED	BY	DATE
NOTE BOOK	PLOTTED		
	TEMPLATE		
	PRINT		
	AREAS CHECKED		

FINAL SURVEY	SURVEYED	BY	DATE
NOTE BOOK	PLOTTED		
	TEMPLATE		
	PRINT		
	AREAS CHECKED		

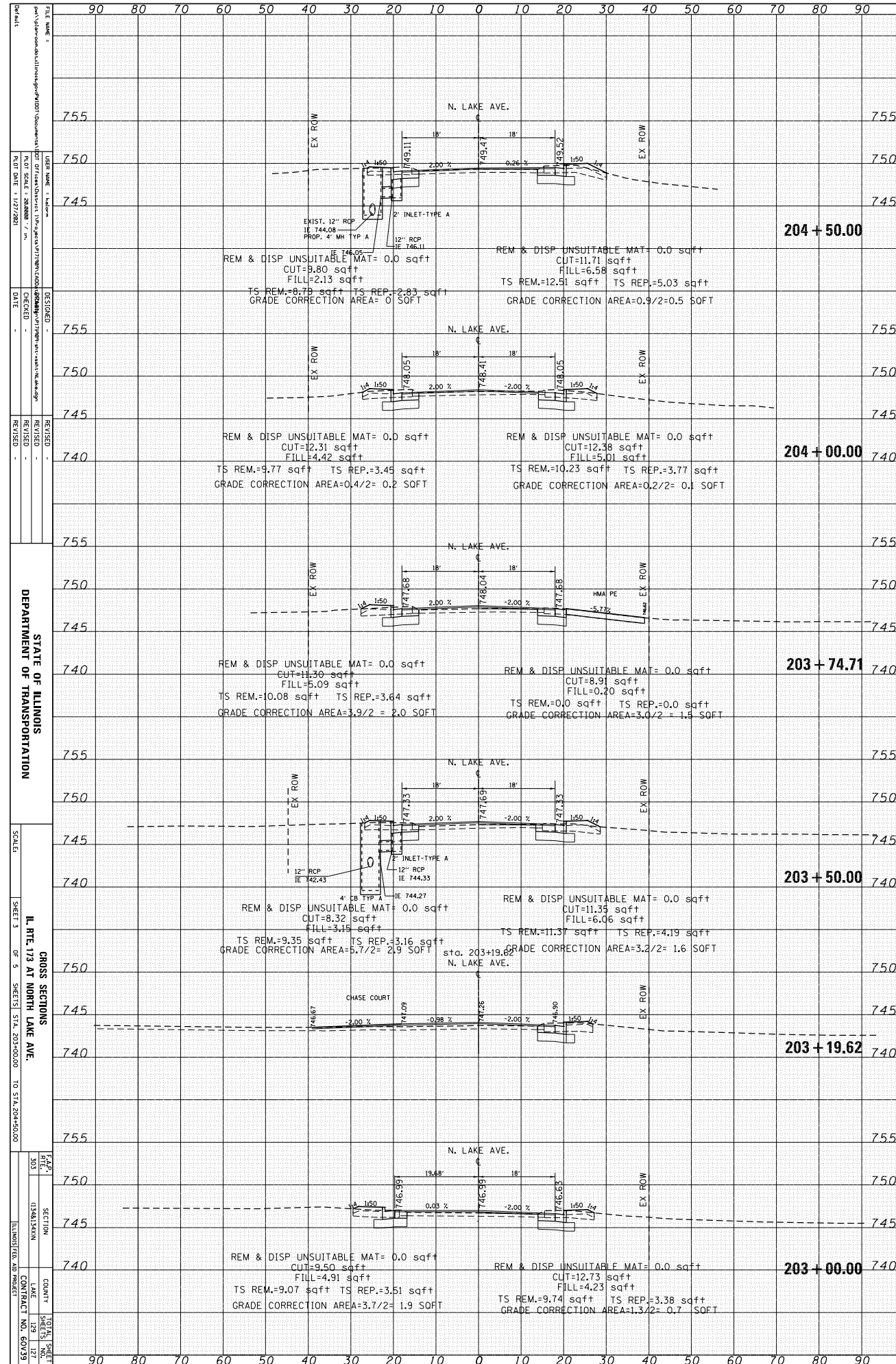

ORIGINAL SURVEY	SURVEYED	BY	DATE
NOTE BOOK	PLOTTED		
	TEMPLATE		
	AREAS CHECKED		

FINAL SURVEY	SURVEYED	BY	DATE
NOTE BOOK	PLOTTED		
	TEMPLATE		
	AREAS CHECKED		

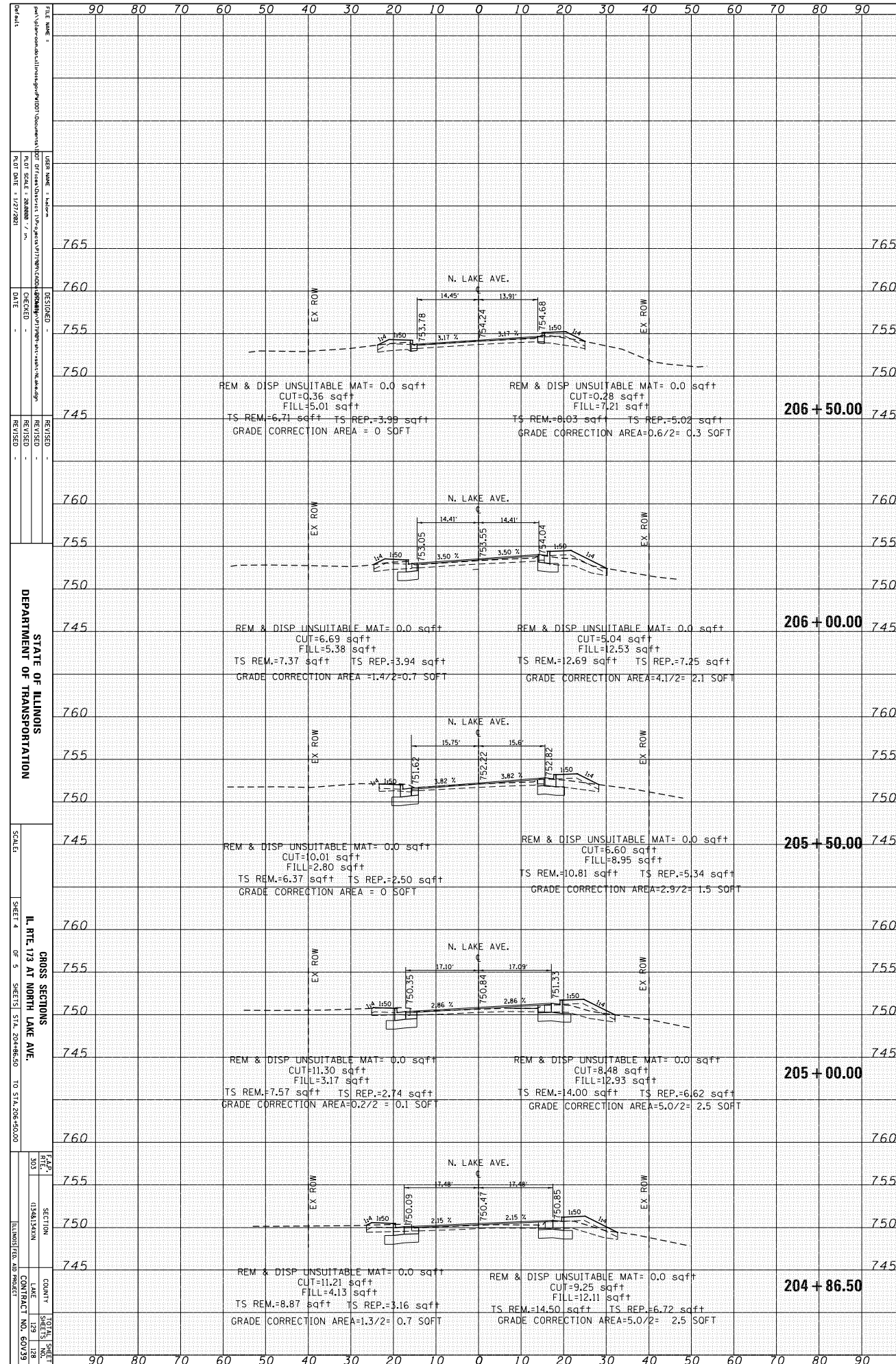

ORIGINAL SURVEY	SURVEYED	BY	DATE
NOTE BOOK	PLOTTED		
NO.	TEMPLATE		
	AREA		
	AREAS CHECKED		

FINAL SURVEY	SURVEYED	BY	DATE
NOTE BOOK	PLOTTED		
NO.	TEMPLATE		
	AREA		
	AREAS CHECKED		

