

STATE OF ILLINOIS
DEPARTMENT OF TRANSPORTATION

F.A.P. RTE.	SECTION	COUNTY	TOTAL SHEETS	SHEET NO.
320	D7 BRIDGE REPAIRS 2021-7	MACON	33	1
		ILLINOIS	CONTRACT NO. 74994	

FOR INDEX OF SHEETS, SEE SHEET NO. 2

**PROPOSED
HIGHWAY PLANS**

FAP ROUTE 320(US 36 /IL 121)
SECTION D7 BRIDGE REPAIRS 2021-7
PROJECT NHPP-QRSE(266)
BRIDGE REPAIR
MACON COUNTY

C-97-079-20

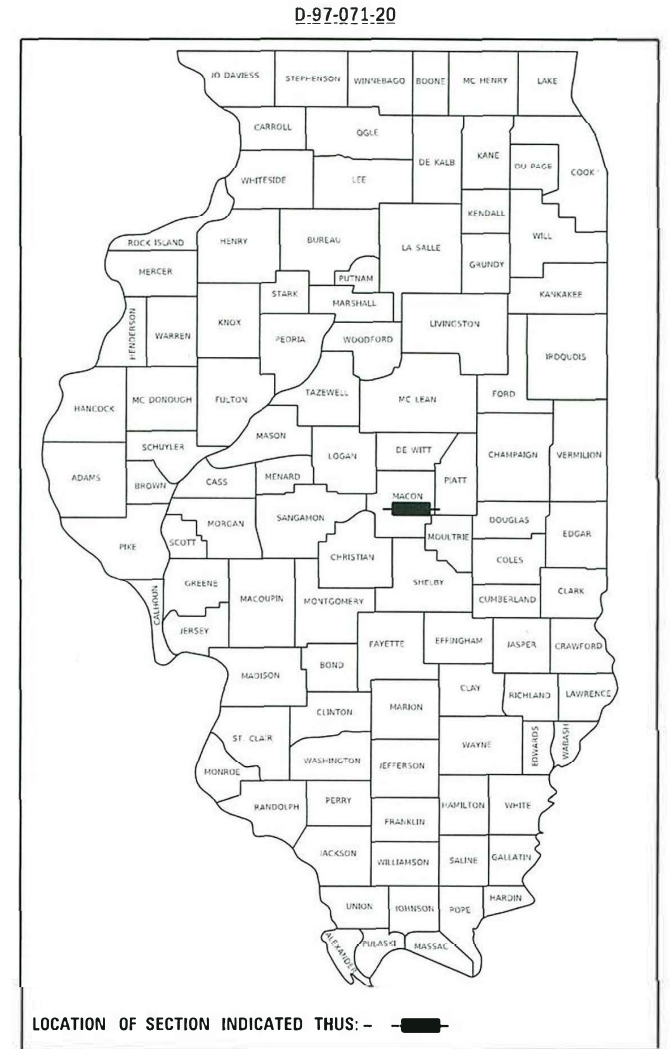

ADT = 22,200 (2019)

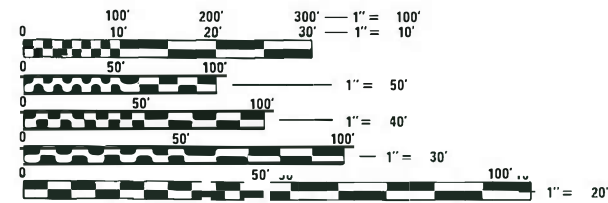

FULL SIZE PLANS HAVE BEEN PREPARED USING STANDARD ENGINEERING SCALES. REDUCED SIZED PLANS WILL NOT CONFORM TO STANDARD SCALES. IN MAKING MEASUREMENTS ON REDUCED PLANS, THE ABOVE SCALES MAY BE USED.

J.U.L.I.E.
JOINT UTILITY LOCATION INFORMATION FOR EXCAVATION
1-800-892-0123
OR 811

PROJECT ENGINEER: TOM RONAN
PROJECT MANAGER: RYAN WEI

CONTRACT NO. 74994

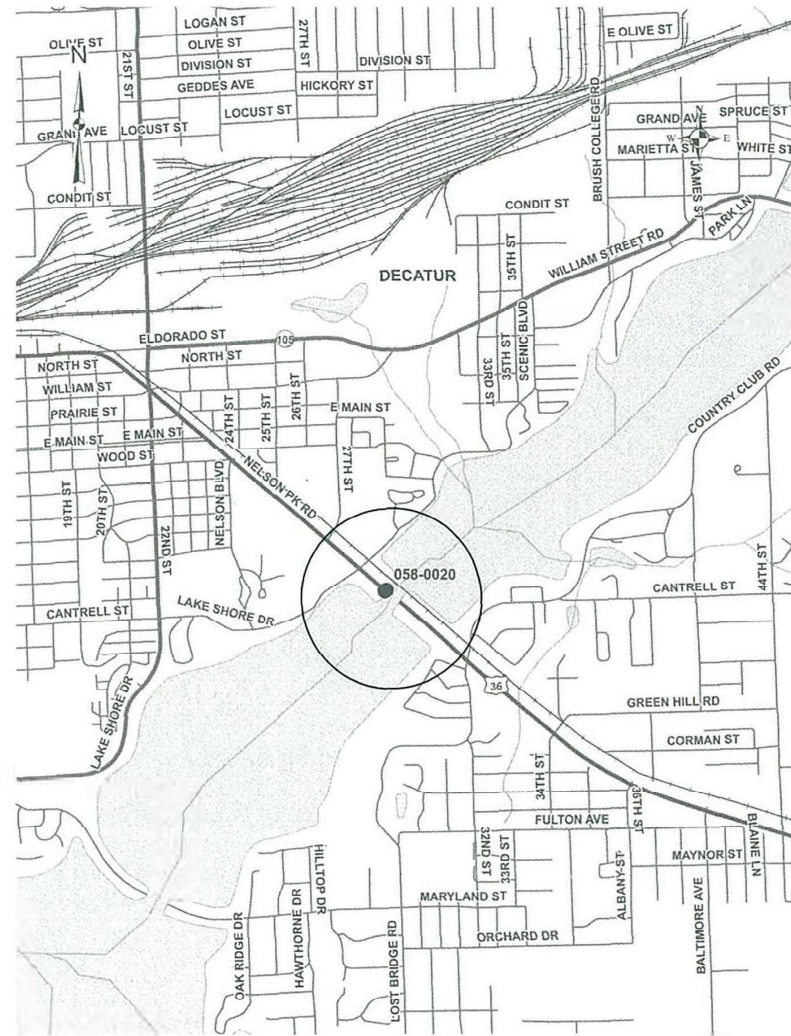

STATE OF ILLINOIS
DEPARTMENT OF TRANSPORTATION

SUBMITTED January 19, 2021

Jeffrey P. Myerly
REGIONAL ENGINEER

March 19, 2021
Scott A. Etk
ENGINEER OF DESIGN AND ENVIRONMENT

March 19, 2021
James J. Gu
DIRECTOR OF HIGHWAYS PROJECT IMPLEMENTATION

PRINTED BY THE AUTHORITY
OF THE STATE OF ILLINOIS

INDEX OF SHEETS

SHEET NO.	ITEM
1	COVER SHEET
2	INDEX OF SHEETS, GENERAL NOTES, & HIGHWAY STANDARDS
3-4	SUMMARY OF QUANTITIES
5	SCHEDULES OF QUANTITIES
6-15	TRAFFIC CONTROL PLAN SHEETS
16-32	STRUCTURE PLAN SHEETS AND DETAILS
33	CONCRETE MEDIAN DETAIL

GENERAL NOTES

THIS PROJECT IS LOCATED ON US 36 OVER LAKE DECATUR IN MACON COUNTY. THIS WORK INCLUDES THE FOLLOWING REPAIRS TO STRUCTURE 058-0020 CARRYING US 36 OVER LAKE DECATUR: REPLACEMENT OF EXISTING EXPANSION JOINTS, BEARING REPLACEMENT, STEEL BEAM STRUCTURE REPAIR, CURB REPAIR, PAPAPET REPAIR, FULL DEPTH DECK PATCHING, SCARIFICATION AND CONCRETE OVERLAY, AND ALL OTHER WORK NECESSARY TO COMPLETE THIS PROJECT.

COMBINATION CONCRETE CURB AND GUTTER TYPE B - 6.12 IS TO BE USED TO INSTALL NOSE RAMPS ON THE EDGES OF CONCRETE MEDIAN REMOVAL.

PCC BASE COURSE, 9" IS TO BE USED DURING STAGE I & II FOR TRAFFIC WHERE THE CONCRETE MEDIAN HAS BEEN REMOVED.

THE TOTAL QUANTITY OF PREFORMED PLASTIC PAVEMENT MARKING, TYPE B - LINE 4" CONSISTS OF 1128 FEET OF YELLOW.

THE TOTAL QUANTITY OF PREFORMED PLASTIC PAVEMENT MARKING, TYPE B - LINE 4" CONSISTS OF 282 FEET OF WHITE.

LIST OF ILLINOIS DOT HIGHWAY STANDARDS

STD. NO.	DESCRIPTION
000001-08	STANDARD SYMBOLS, ABBREVIATIONS AND PATTERNS
001006	DECIMAL OF AN INCH AND OF A FOOT
606301-04	PC CONCRETE ISLANDS AND MEDIANS
701101-05	OFF-ROAD OPERATIONS, MULTI-LANE, 15' AWAY TO EDGE OF PAVEMENT
701106-02	OFF-ROAD OPERATIONS, MULTI-LANE, 15' MINIMUM AWAY FROM PAVEMENT EDGE
701423-10	TRAFFIC CONTROL DEVICES
701601-09	URBAN LANE CLOSURE, MULTILANE, 1W OR 2W WITH NONTRAVERSABLE MEDIAN
701611-01	URBAN HALF ROAD CLOSURE, MULTILANE, 2W WITH MOUNTABLE MEDIAN
701901-08	TRAFFIC CONTROL DEVICES
704001-08	TRAFFIC CONTROL DEVICES

MODEL: Default
 FILE NAME: \\paulhammon.dot.illinois.gov\PIWDOT\Documents\IDOT_Offices\District_7\Projects\7499A\CA00Data\CAD\Drawings\7499A-4-16-gen-nots.dgn

USER NAME = steffenmk	DESIGNED -	REVISED -
	DRAWN -	REVISED -
PLOT SCALE = 100,0000' / in.	CHECKED -	REVISED -
PLOT DATE = 1/22/2021	DATE -	REVISED -

**STATE OF ILLINOIS
DEPARTMENT OF TRANSPORTATION**

**INDEX, STANDARDS
& GENERAL NOTES**

SCALE: SHEET 1 OF 1 SHEETS STA. TO STA.

F.A.P. RTE.	SECTION	COUNTY	TOTAL SHEETS	SHEET NO.
320	D7 BRIDGE REPAIRS 2021-7	MACON	33	2
CONTRACT NO. 74994				
ILLINOIS FED. AID PROJECT				

80% FED
20% STATE
URBAN

80% FED
20% STATE
URBAN

SUMMARY OF QUANTITIES			TOTAL QUANTITIES	CONSTRUCTION TYPE CODE		
CODE NO	ITEM	UNIT		0047		
35300400	PORTLAND CEMENT CONCRETE BASE COURSE 9"	SO YD	242	242		
50102400	CONCRETE REMOVAL	CU YD	33	33		
50157300	PROTECTIVE SHIELD	SO YD	2707	2707		
50300255	CONCRETE SUPERSTRUCTURE	CU YD	33	33		
50300260	BRIDGE DECK GROOVING	SO YD	2568	2568		
50300300	PROTECTIVE COAT	SO YD	2815	2815		
50500405	FURNISHING AND ERECTING STRUCTURAL STEEL	POUND	5220	5220		
50800205	REINFORCEMENT BARS, EPOXY COATED	POUND	6250	6250		
50800515	BAR SPLICERS	EACH	44	44		
52000110	PREFORMED JOINT STRIP SEAL	FOOT	136	136		
52100010	ELASTOMERIC BEARING ASSEMBLY, TYPE I	EACH	10	10		
52100020	ELASTOMERIC BEARING ASSEMBLY, TYPE II	EACH	10	10		
52100520	ANCHOR BOLTS, 1"	EACH	40	40		

SUMMARY OF QUANTITIES			TOTAL QUANTITIES	CONSTRUCTION TYPE CODE		
CODE NO	ITEM	UNIT		0047		
60603800	COMBINATION CONCRETE CURB AND GUTTER, TYPE B-6.12	FOOT	45	45		
67000400	ENGINEER'S FIELD OFFICE, TYPE A	CAL MO	5	5		
67100100	MOBILIZATION	L SUM	1	1		
70102630	TRAFFIC CONTROL AND PROTECTION, STANDARD 701601	L SUM	1	1		
70102634	TRAFFIC CONTROL AND PROTECTION, STANDARD 701611	L SUM	1	1		
70107006	PAVEMENT MARKING BLACKOUT TAPE, 6"	FOOT	3565	3565		
70107025	CHANGEABLE MESSAGE SIGN	CAL DA	28	28		
70300100	SHORT TERM PAVEMENT MARKING	FOOT	865	865		
70300150	SHORT TERM PAVEMENT MARKING REMOVAL	SO FT	288	288		
70300220	TEMPORARY PAVEMENT MARKING - LINE 4"	FOOT	1410	1410		
70400100	TEMPORARY CONCRETE BARRIER	FOOT	756	756		
70400200	RELOCATE TEMPORARY CONCRETE BARRIER	FOOT	756	756		

MODEL: Default
 FILE NAME: p:\pub\harronm.dwg
 PROJECT: 7499A\CA00Data\CAD\Drawings\7499A-4-15-2003.dwg

USER NAME = steffenmk	DESIGNED -	REVISED -
PLOT SCALE = 100,0000' / in.	DRAWN -	REVISOR -
PLOT DATE = 1/22/2021	CHECKED -	REVISIONS -
	DATE -	

**STATE OF ILLINOIS
DEPARTMENT OF TRANSPORTATION**

SUMMARY OF QUANTITIES

SCALE: SHEET OF SHEETS STA. TO STA.

F.A.P. RTE.	SECTION	COUNTY	TOTAL SHEETS	SHEET NO.
320	D7 BRIDGE REPAIRS 2021-7	MACON	33	3
CONTRACT NO. 7499A				
ILLINOIS FED. AID PROJECT				

80% FED
20% STATE
URBAN

80% FED
20% STATE
URBAN

SUMMARY OF QUANTITIES			TOTAL QUANTITIES	CONSTRUCTION TYPE CODE		
CODE NO	ITEM	UNIT		0047		
* 78000200	THERMOPLASTIC PAVEMENT MARKING - LINE 4"	FOOT	4108	4108		
* 78003110	PREFORMED PLASTIC PAVEMENT MARKING, TYPE B - LINE 4"	FOOT	1410	1410		
* 78100100	RAISED REFLECTIVE PAVEMENT MARKER	EACH	46	46		
78300200	RAISED REFLECTIVE PAVEMENT MARKER REMOVAL	EACH	46	46		
78300202	PAVEMENT MARKING REMOVAL - WATER BLASTING	SO FT	470	470		
X4403300	CONCRETE MEDIAN REMOVAL	SO FT	2176	2176		
X6061702	CONCRETE MEDIAN, TYPE SM (DOWELLED)	SO FT	2176	2176		
X7010035	TRAFFIC CONTROL AND PROTECTION, STANDARD 701423 (SPECIAL)	EACH	2	2		
X7040125	PINNING TEMPORARY CONCRETE BARRIER	EACH	363	363		
* X7830070	GROOVING FOR RECESSED PAVEMENT MARKING 5"	FOOT	4108	4108		
Z0001899	JACK AND REMOVE EXISTING BEARINGS	EACH	20	20		
Z0001905	STRUCTURAL STEEL REPAIR	POUND	1380	1380		

SUMMARY OF QUANTITIES			TOTAL QUANTITIES	CONSTRUCTION TYPE CODE		
CODE NO	ITEM	UNIT		0047		
Z0012110	BRIDGE DECK FLY ASH OR GGBF SLAG CONCRETE OVERLAY, 2 1/4"	SO YD	2733	2733		
Z0012142	BRIDGE DECK SCARIFICATION 2 1/4"	SO YD	2733	2733		
Z0012754	STRUCTURAL REPAIR OF CONCRETE (DEPTH EQUAL TO OR LESS THAN 5 INCHES)	SO FT	425	425		
Z0016001	DECK SLAB REPAIR (FULL DEPTH, TYPE I)	SO YD	22	22		
Z0016002	DECK SLAB REPAIR (FULL DEPTH, TYPE II)	SO YD	137	137		

* SPECIALTY ITEM

REV. - MS

MODEL: Default
 FILE: MacBt_PlanRoom.dwg
 PROJECT: 17994\CAD\DATA\CAD\Drawings\DOT Office\District 7\Projects\17994\CAD\DATA\CAD\Drawings\DOT Office\District 7\Projects\17994-Plan-SOQ.dwg

USER NAME = steffenmk	DESIGNED -	REVISED -
	DRAWN -	REVISED -
PLOT SCALE = 100.0000' / in.	CHECKED -	REVISED -
PLOT DATE = 1/22/2021	DATE -	REVISED -

STATE OF ILLINOIS
DEPARTMENT OF TRANSPORTATION

SUMMARY OF QUANTITIES

SCALE: SHEET OF SHEETS STA. TO STA.

F.A.P. RTE.	SECTION	COUNTY	TOTAL SHEETS	SHEET NO.
320	D7 BRIDGE REPAIRS 2021-7	MACON	33	4
ILLINOIS FED. AID PROJECT			CONTRACT NO. 74994	

MODEL: Default
 FILE NAME: p:\pub\mroom.dwt\illinois\pwr\PIWIDOT\Documents\IDOT_Offices\Dist\ref_7\Project\7499A\CADD\Drawings\7499A-SP-SC-Schedule.dwg

CONCRETE MEDIAN SCHEDULE						
LOCATION			CONCRETE MEDIAN, TYPE SM (DOWELLED)	CONCRETE MEDIAN REMOVAL	PORTLAND CEMENT CONCRETE BASE COURSE 9"	COMBINATION CONCRETE CURB AND GUTTER, TYPE B-6.12
			(SQ FT)	(SQ FT)	(SQ YD)	(FOOT)
166+61	TO	167+89	512	512	57	0
176+65	TO	177+78	452	452	50	0
178+71	TO	181+74	1212	1212	135	0
TOTAL =			2176	2176	242	45

CONCRETE BARRIER SCHEDULE					
LOCATION			TEMPORARY CONCRETE BARRIER	RELOCATE TEMPORARY CONCRETE BARRIER	PINNING TEMPORARY CONCRETE BARRIER
			(FOOT)	(FOOT)	(EACH)
STAGE 1					
168+60	TO	170+04	144	0	35
170+04	TO	176+16	612	0	147
STAGE 2					
170+52	TO	176+64	0	612	147
176+64	TO	178+08	0	144	35
TOTAL =			756	756	363

PAVEMENT MARKING SCHEDULE									
STATION TO STATION	PERFORMED PLASTIC PAVEMENT MARKING - LINE WHITE 4"	PERFORMED PLASTIC PAVEMENT MARKING - LINE YELLOW 4"	TEMPORARY PAVEMENT MARKING - WHITE LINE 4"	TEMPORARY PAVEMENT MARKING - YELLOW LINE 4"	SHORT TERM PAVEMENT MARKING	SHORT TERM PAVEMENT MARKING REMOVAL	PAVEMENT MARKING REMOVAL - WATER BLASTING	PAVEMENT MARKING BLACKOUT TAPE - LINE 6"	GROOVING FOR RECESSED PAVEMENT MARKING 5"
	FT	FT	FT	FT	FT	SQ FT	SQ FT	FT	FOOT
EASTBOUND	141	564	141	564	434	145	235	1847	
WESTBOUND	141	564	141	564	431	144	235	1718	
TOTALS	282	1128	282	1128	865	1477	470	3565	1410

USER NAME = steffemk	DESIGNED -	REVISED -
	DRAWN -	REVISED -
PLOT SCALE = 100,0000 ' / in.	CHECKED -	REVISED -
PLOT DATE = 1/22/2021	DATE -	REVISED -

**STATE OF ILLINOIS
DEPARTMENT OF TRANSPORTATION**

SCHEDULE OF QUANTITIES			
SCALE:	SHEET	OF	SHEETS

F.A.P. RTE.	SECTION	COUNTY	TOTAL SHEETS	SHEET NO.
320	D7 BRIDGE REPAIRS 2021-7	MACON	33	5
CONTRACT NO. 74994				
ILLINOIS FED. AID PROJECT				

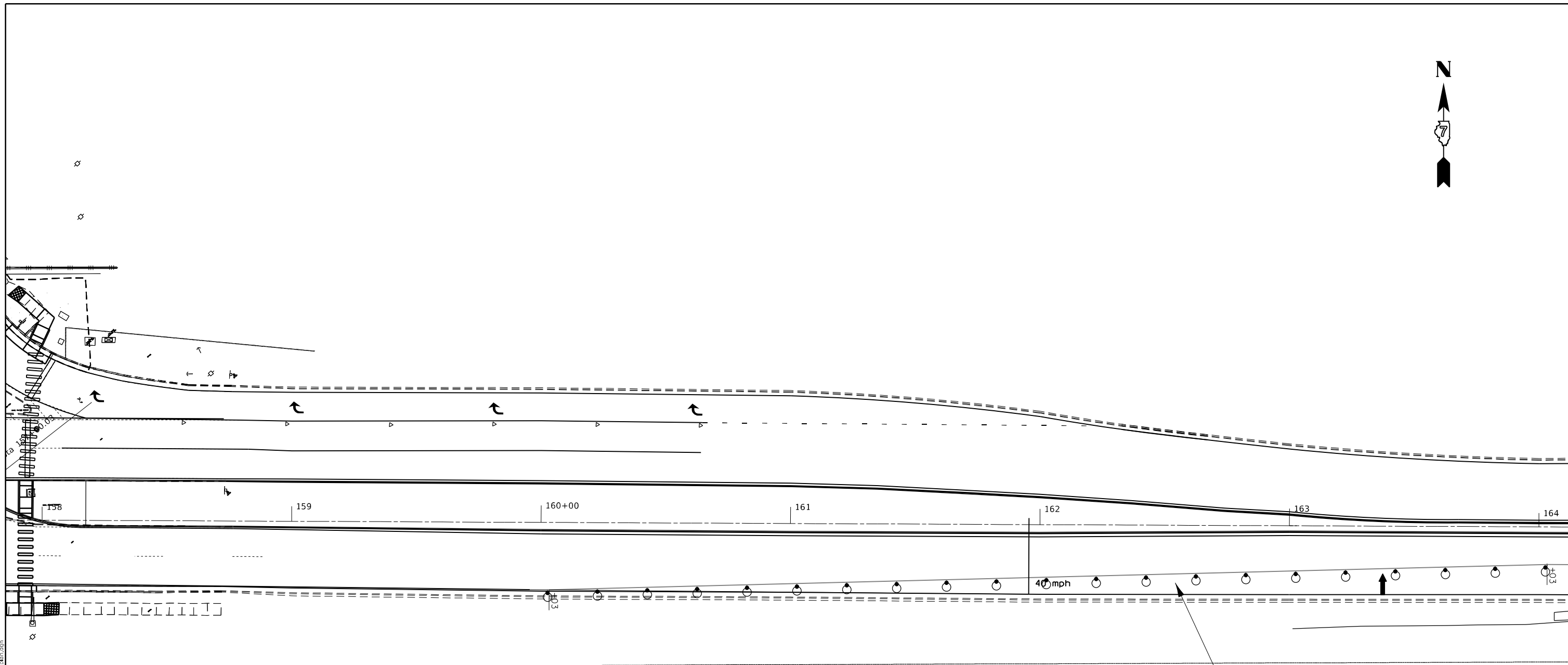

LEGEND

- DRUM WITH STEADY BURN MONODIRECTIONAL LIGHT
(PLACE AT 50' CENTERS)
- ⦿ TYPE II BARRICADE WITH STEADY BURN
MONODIRECTIONAL LIGHT (PLACE AT 50' CENTERS)
- ⬆ TYPE III BARRICADE, WITH FLASHING MONODIRECTIONAL LIGHTS
- ⬆ SIGN
- ↑ ARROW BOARD

WHITE WET REFLECTIVE
PAVEMENT MARKING 4"

MODEL: Default
 FILE NAME: \\paulhammon.dot.illinois.gov\PIWDOT\Documents\DOT_Offices\District 7\Projects\7799A\CADD\Drawings\7799A-CH-480.dwg

USER NAME = steffenmk	DESIGNED -	REVISED -
	DRAWN -	REVISED -
PLOT SCALE = 40,0000 * / in.	CHECKED -	REVISED -
PLOT DATE = 1/22/2021	DATE -	REVISED -

**STATE OF ILLINOIS
DEPARTMENT OF TRANSPORTATION**

STAGE 1 TRAFFIC CONTROL

SCALE: SHEET OF 7 SHEETS STA. TO STA.

F.A.P. RTE.	SECTION	COUNTY	TOTAL SHEETS	SHEET NO.
320	D7 BRIDGE REPAIRS 2021-7	MACON	33	6
ILLINOIS FED. AID PROJECT			CONTRACT NO. 77994	



LEGEND

- DRUM WITH STEADY BURN MONODIRECTIONAL LIGHT (PLACE AT 50' CENTERS)
- ⊥ TYPE II BARRICADE WITH STEADY BURN MONODIRECTIONAL LIGHT (PLACE AT 50' CENTERS)
- ⤴ DIRECTION INDICATOR BARRICADE WITH STEADY BURN MONODIRECTIONAL LIGHT. (PLACE AT 20' CENTERS)
- ⊥ TYPE III BARRICADE, WITH FLASHING MONODIRECTIONAL LIGHTS
- ⊥ SIGN
- ↑ ARROW BOARD

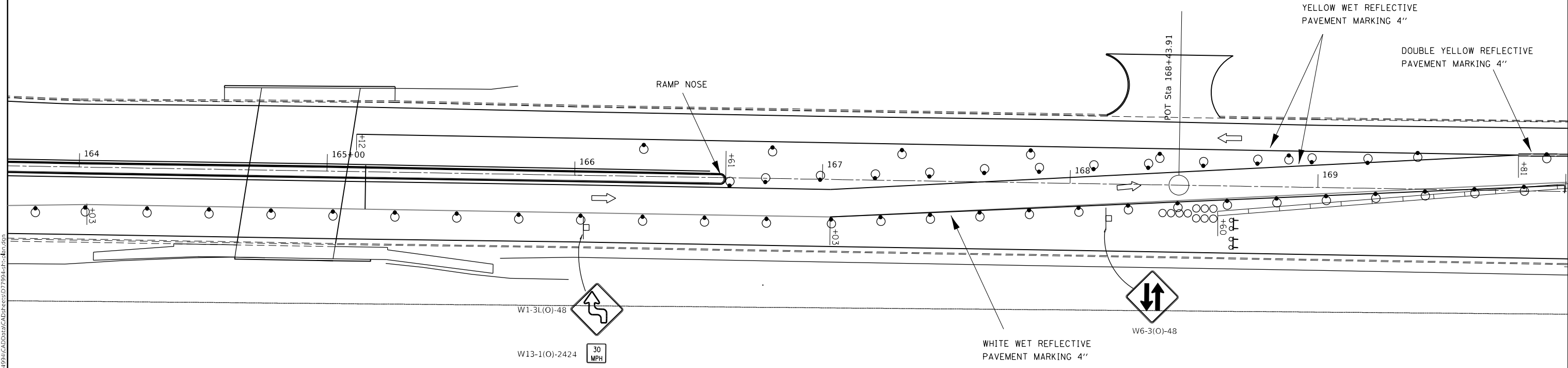

MODEL: Default
 FILE NAME: p:\pub\mroom.dwg
 PROJECT: 77994\CAAD\Drawings\DOT_Offices\Drawings\77994-01-01.dwg

USER NAME = steffenmk	DESIGNED -	REVISED -
	DRAWN -	REVISED -
PLOT SCALE = 40,0000 * / in.	CHECKED -	REVISED -
PLOT DATE = 1/22/2021	DATE -	REVISED -

**STATE OF ILLINOIS
DEPARTMENT OF TRANSPORTATION**







STAGE 1 TRAFFIC CONTROL

SCALE: SHEET OF 7 SHEETS STA. TO STA.

F.A.P. RTE.	SECTION	COUNTY	TOTAL SHEETS	SHEET NO.
320	D7 BRIDGE REPAIRS 2021-7	MACON	33	7
CONTRACT NO. 77994				
ILLINOIS FED. AID PROJECT				



LEGEND

-  DRUM WITH STEADY BURN MONODIRECTIONAL LIGHT
(PLACE AT 50' CENTERS)
-  TYPE II BARRICADE WITH STEADY BURN
MONODIRECTIONAL LIGHT (PLACE AT 50' CENTERS)
-  DIRECTION INDICATOR BARRICADE WITH STEADY BURN
MONODIRECTIONAL LIGHT. (PLACE AT 20' CENTERS)
-  TYPE III BARRICADE, WITH FLASHING MONODIRECTIONAL LIGHTS
-  SIGN
-  ARROW BOARD

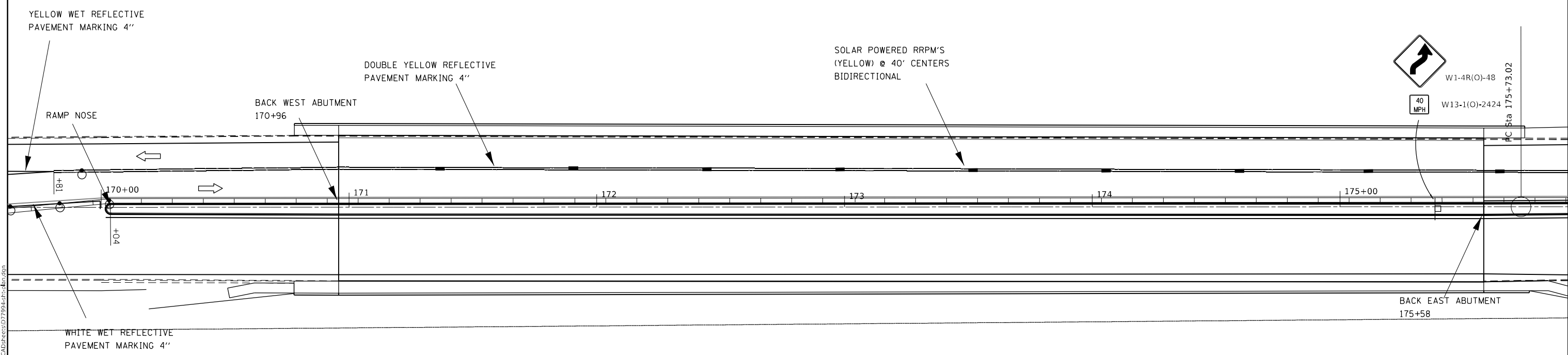

MODEL: Default
 FILE NAME: p:\pub\lanscom.dwg
 PROJECT: 77994\CAADDATA\CADD\Drawings\77994-dt-8.dwg
 PROJECT: 77994\CAADDATA\CADD\Drawings\77994-dt-8.dwg

USER NAME = steffenmk	DESIGNED -	REVISED -
	DRAWN -	REVISED -
PLOT SCALE = 40,0000 * / in.	CHECKED -	REVISED -
PLOT DATE = 1/22/2021	DATE -	REVISED -

**STATE OF ILLINOIS
DEPARTMENT OF TRANSPORTATION**

STAGE 1 TRAFFIC CONTROL

SCALE: SHEET OF 7 SHEETS STA. TO STA.

F.A.P. RTE.	SECTION	COUNTY	TOTAL SHEETS	SHEET NO.
320	D7 BRIDGE REPAIRS 2021-7	MACON	33	8
CONTRACT NO. 77994			ILLINOIS FED. AID PROJECT	



LEGEND

- DRUM WITH STEADY BURN MONODIRECTIONAL LIGHT (PLACE AT 50' CENTERS)
- TYPE II BARRICADE WITH STEADY BURN MONODIRECTIONAL LIGHT (PLACE AT 50' CENTERS)
- DIRECTION INDICATOR BARRICADE WITH STEADY BURN MONODIRECTIONAL LIGHT (PLACE AT 20' CENTERS)
- TYPE III BARRICADE, WITH FLASHING MONODIRECTIONAL LIGHTS
- SIGN
- ARROW BOARD

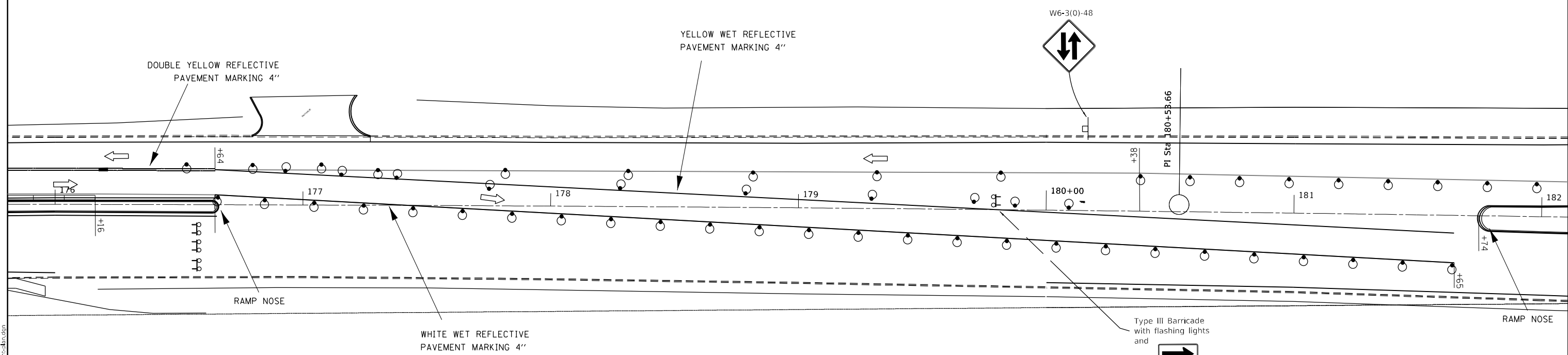

EXIST. CURVE C16
 PI STA. = 180+53.66
 $I = 1^{\circ} 21' 43''$ (RT)
 $D = 0^{\circ} 08' 30''$
 $R = 40,439.18'$
 $T = 480.64'$
 $L = 961.23'$
 $E = 2.86'$
 $e = \text{---}$
 $T.R. = \text{---}$
 $S.E. RUN = \text{---}$
 $P.C. STA. = 175+73.02$
 $P.T. STA. = 185+34.26$

MODEL: Default
 FILE NAME: p:\pub\baronon.dwg
 PROJECT: 77994\CA00Data\CAD\Drawings\77994-07-01.dwg

USER NAME = steffenmk	DESIGNED -	REVISED -
	DRAWN -	REVISED -
PLOT SCALE = 40,0000 * / in.	CHECKED -	REVISED -
PLOT DATE = 1/22/2021	DATE -	REVISED -

**STATE OF ILLINOIS
DEPARTMENT OF TRANSPORTATION**

STAGE 1 TRAFFIC CONTROL

SCALE: SHEET OF 7 SHEETS STA. TO STA.

F.A.P. RTE.	SECTION	COUNTY	TOTAL SHEETS	SHEET NO.
320	D7 BRIDGE REPAIRS 2021-7	MACON	33	9
CONTRACT NO. 77994				
ILLINOIS FED. AID PROJECT				

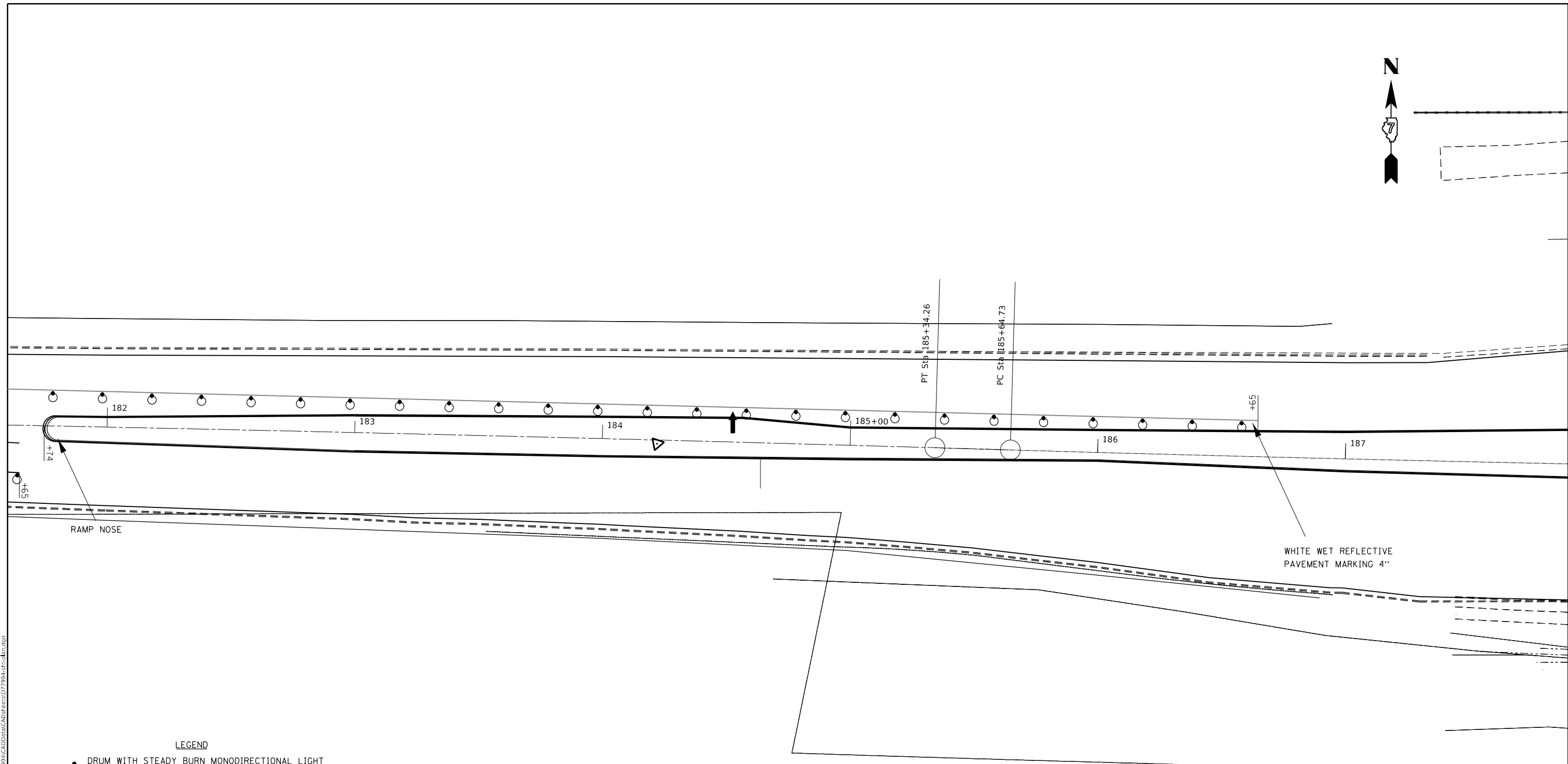

LEGEND

- DRUM WITH STEADY BURN MONODIRECTIONAL LIGHT (PLACE AT 50' CENTERS)
- TYPE II BARRICADE WITH STEADY BURN MONODIRECTIONAL LIGHT (PLACE AT 50' CENTERS)
- DIRECTION INDICATOR BARRICADE WITH STEADY BURN MONODIRECTIONAL LIGHT. (PLACE AT 20' CENTERS)
- TYPE III BARRICADE, WITH FLASHING MONODIRECTIONAL LIGHTS
- SIGN
- ARROW BOARD

MODEL: Default
 FILE NAME: p:\pub\baronon.dwg
 PROJECT: 7199A\CAD\Drawings\DOT_Offices\Drawings\7199A\CAD\Drawings\DOT7199A.dwg

USER NAME = steffenmk	DESIGNED -	REVISED -
PLOT SCALE = 40,0000 */ in.	DRAWN -	REVISIED -
PLOT DATE = 1/22/2021	CHECKED -	REVISIED -
	DATE -	REVISIED -

**STATE OF ILLINOIS
DEPARTMENT OF TRANSPORTATION**

STAGE 1 TRAFFIC CONTROL

SCALE: SHEET OF 7 SHEETS STA. TO STA.

F.A.P. RTE.	SECTION	COUNTY	TOTAL SHEETS	SHEET NO.
320	D7 BRIDGE REPAIRS 2021-7	MACON	33	10
ILLINOIS FED. AID PROJECT			CONTRACT NO. 77994	

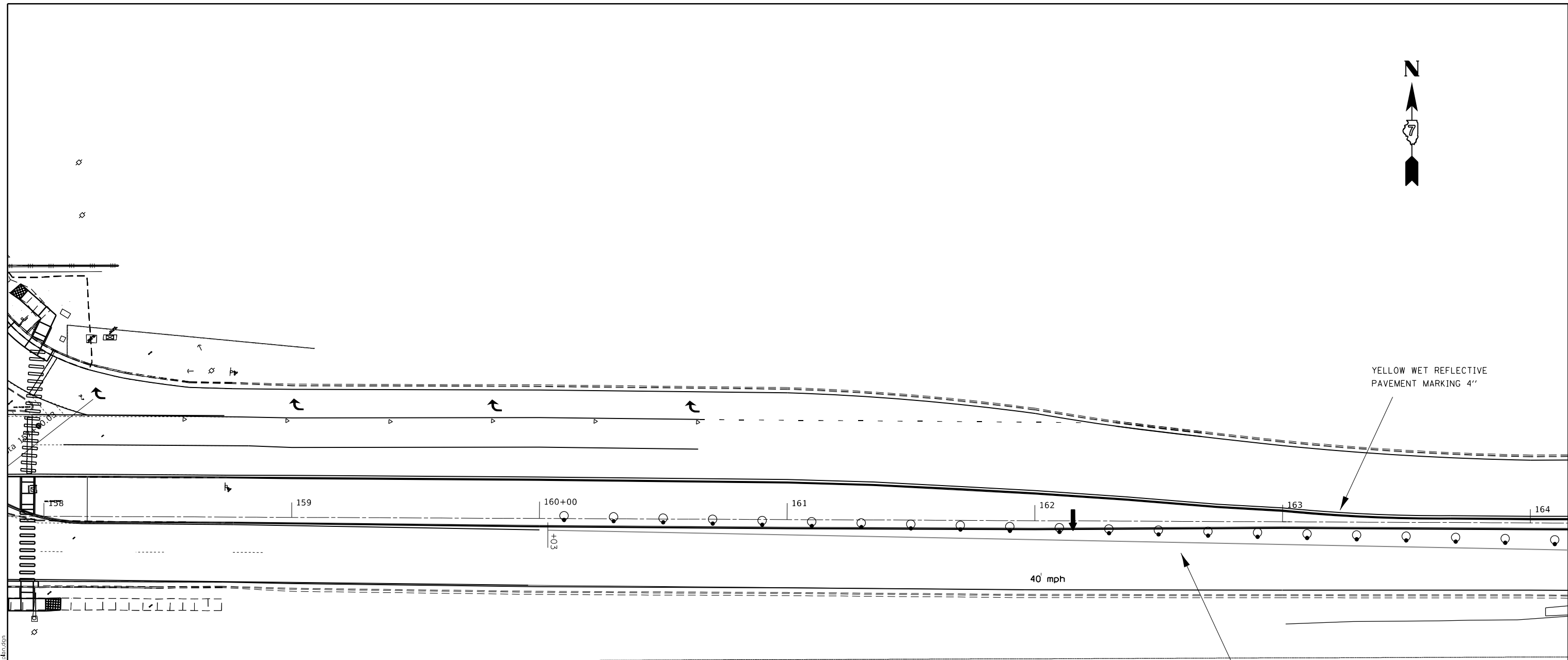

LEGEND

- DRUM WITH STEADY BURN MONODIRECTIONAL LIGHT
(PLACE AT 50' CENTERS)
- ⦿ TYPE II BARRICADE WITH STEADY BURN
MONODIRECTIONAL LIGHT (PLACE AT 50' CENTERS)
- ⤴ DIRECTION INDICATOR BARRICADE WITH STEADY BURN
MONODIRECTIONAL LIGHT. (PLACE AT 20' CENTERS)
- ⦶ TYPE III BARRICADE, WITH FLASHING MONODIRECTIONAL LIGHTS
- ⊞ SIGN
- ↑ ARROW BOARD

MODEL: Default
 FILE NAME: p:\pub\harronm.dwg
 PROJECT: 71994\CA00Data\CAD\Drawings\71994-07-01.dwg
 PROJECT: 71994\CA00Data\CAD\Drawings\71994-07-01.dwg







USER NAME = steffenmk	DESIGNED -	REVISED -
	DRAWN -	REVISED -
PLOT SCALE = 40,0000 */ in.	CHECKED -	REVISED -
PLOT DATE = 1/22/2021	DATE -	REVISED -

**STATE OF ILLINOIS
DEPARTMENT OF TRANSPORTATION**

STAGE 2 TRAFFIC CONTROL

SCALE: SHEET OF 7 SHEETS STA. TO STA.

F.A.P. RTE.	SECTION	COUNTY	TOTAL SHEETS	SHEET NO.
320	D7 BRIDGE REPAIRS 2021-7	MACON	33	11
ILLINOIS FED. AID PROJECT			CONTRACT NO. 77994	

- LEGEND**
-  DRUM WITH STEADY BURN MONODIRECTIONAL LIGHT (PLACE AT 50' CENTERS)
 -  TYPE II BARRICADE WITH STEADY BURN MONODIRECTIONAL LIGHT (PLACE AT 50' CENTERS)
 -  DIRECTION INDICATOR BARRICADE WITH STEADY BURN MONODIRECTIONAL LIGHT. (PLACE AT 20' CENTERS)
 -  TYPE III BARRICADE, WITH FLASHING MONODIRECTIONAL LIGHTS
 -  SIGN
 -  ARROW BOARD

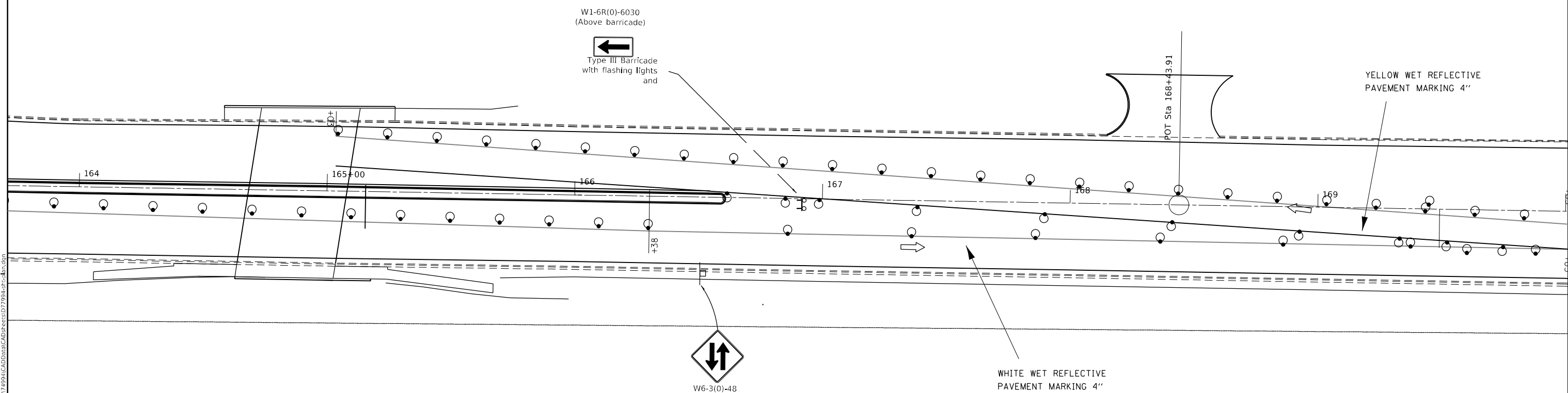

MODEL: Default
 FILE NAME: p:\pub\lhammon.dwg
 PROJECT: 7799A\CADD\Drawings\DOT_Offices\Drawings\7799A\ch-48.dwg







USER NAME = steffenmk	DESIGNED -	REVISED -
	DRAWN -	REVISED -
PLOT SCALE = 40,0000 * / in.	CHECKED -	REVISED -
PLOT DATE = 1/22/2021	DATE -	REVISED -

**STATE OF ILLINOIS
DEPARTMENT OF TRANSPORTATION**

STAGE 2 TRAFFIC CONTROL

SCALE: SHEET OF 7 SHEETS STA. TO STA.

F.A.P. RTE.	SECTION	COUNTY	TOTAL SHEETS	SHEET NO.
320	D7 BRIDGE REPAIRS 2021-7	MACON	33	12
CONTRACT NO. 77994				
ILLINOIS FED. AID PROJECT				

- LEGEND**
-  DRUM WITH STEADY BURN MONODIRECTIONAL LIGHT (PLACE AT 50' CENTERS)
 -  TYPE II BARRICADE WITH STEADY BURN MONODIRECTIONAL LIGHT (PLACE AT 50' CENTERS)
 -  DIRECTION INDICATOR BARRICADE WITH STEADY BURN MONODIRECTIONAL LIGHT. (PLACE AT 20' CENTERS)
 -  TYPE III BARRICADE, WITH FLASHING MONODIRECTIONAL LIGHTS
 -  SIGN
 -  ARROW BOARD

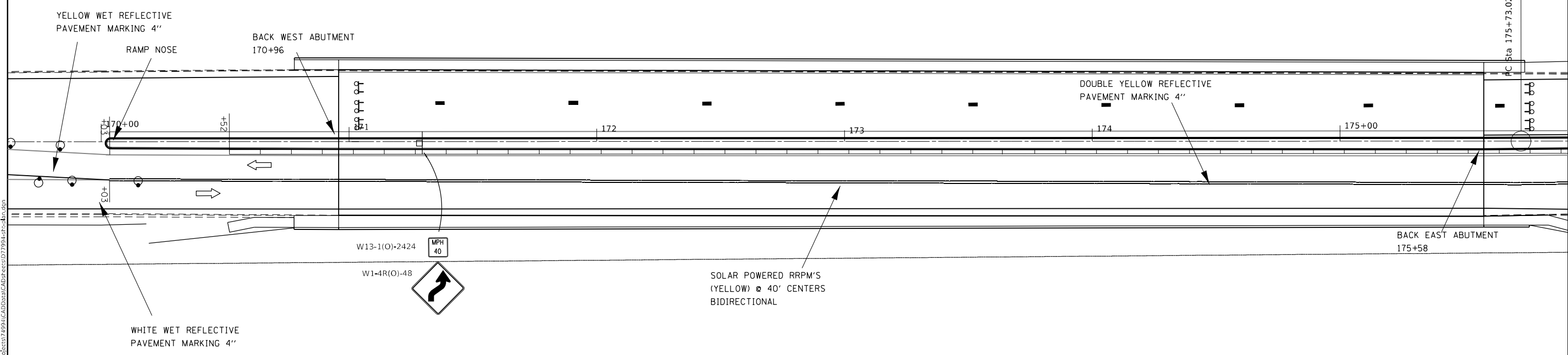

MODEL: Default
 FILE NAME: p:\pub\lhammon.dwg
 PROJECT: 77994\CAAD\Drawings\DOT_Offices\Drawings\77994-01-8-00.dwg

USER NAME = stefenmk	DESIGNED -	REVISED -
PLOT SCALE = 40,0000 * / in.	DRAWN -	REVISED -
PLOT DATE = 1/22/2021	CHECKED -	REVISED -
	DATE -	REVISED -

**STATE OF ILLINOIS
DEPARTMENT OF TRANSPORTATION**

STAGE 2 TRAFFIC CONTROL

SCALE: SHEET OF 7 SHEETS STA. TO STA.

F.A.P. RTE.	SECTION	COUNTY	TOTAL SHEETS	SHEET NO.
320	D7 BRIDGE REPAIRS 2021-7	MACON	33	13
ILLINOIS FED. AID PROJECT			CONTRACT NO. 77994	

- LEGEND**
- DRUM WITH STEADY BURN MONODIRECTIONAL LIGHT (PLACE AT 50' CENTERS)
 - ⊥ TYPE II BARRICADE WITH STEADY BURN MONODIRECTIONAL LIGHT (PLACE AT 50' CENTERS)
 - ⬆️ DIRECTION INDICATOR BARRICADE WITH STEADY BURN MONODIRECTIONAL LIGHT. (PLACE AT 20' CENTERS)
 - ⊥ TYPE III BARRICADE, WITH FLASHING MONODIRECTIONAL LIGHTS
 - ⊥ SIGN
 - ↑ ARROW BOARD

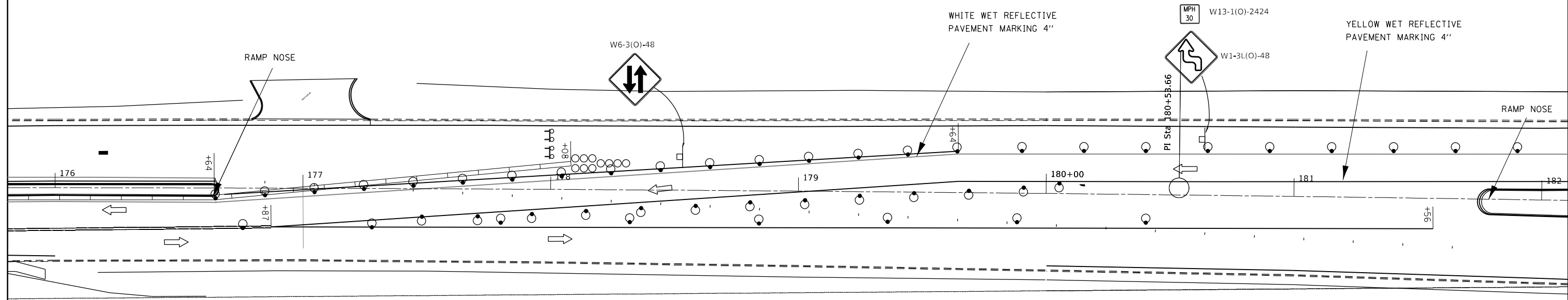

EXIST. CURVE C16
 PI STA. = 180+53.66
 $I = 1^{\circ} 21' 43''$ (RT)
 $D = 0^{\circ} 08' 30''$
 $R = 40,439.18'$
 $T = 480.64'$
 $L = 961.23'$
 $E = 2.86'$
 $e = \text{---}$
 $T.R. = \text{---}$
 $S.E. RUN = \text{---}$
 $P.C. STA. = 175+73.02$
 $P.T. STA. = 185+34.26$

MODEL: Default
 FILE NAME: p:\pub\baronm.dwg
 PROJECT: 77994\CA00Data\CAD\Drawings\77994-ct-4-bn.dwg
 OFFICE: DISTRICT 7
 PLOT DATE: 1/22/2021

USER NAME = steffenmk	DESIGNED -	REVISED -
	DRAWN -	REVISED -
PLOT SCALE = 40,0000 * / in.	CHECKED -	REVISED -
PLOT DATE = 1/22/2021	DATE -	REVISED -

STATE OF ILLINOIS
DEPARTMENT OF TRANSPORTATION

STAGE 2 TRAFFIC CONTROL

SCALE: SHEET OF 7 SHEETS STA. TO STA.

F.A.P. RTE.	SECTION	COUNTY	TOTAL SHEETS	SHEET NO.
320	D7 BRIDGE REPAIRS 2021-7	MACON	33	14
ILLINOIS			FED. AID PROJECT	

CONTRACT NO. 77994



WHITE WET REFLECTIVE
PAVEMENT MARKING 4"

PT STA 185+34.26

PC STA 185+64.73

YELLOW WET REFLECTIVE
PAVEMENT MARKING 4"

RAMP NOSE

182

183

184

185+00

186

187

LEGEND

- DRUM WITH STEADY BURN MONODIRECTIONAL LIGHT
(PLACE AT 50' CENTERS)
- ⊥ TYPE II BARRICADE WITH STEADY BURN
MONODIRECTIONAL LIGHT (PLACE AT 50' CENTERS)
- ⬆ DIRECTION INDICATOR BARRICADE WITH STEADY BURN
MONODIRECTIONAL LIGHT. (PLACE AT 20' CENTERS)
- ⊠ TYPE III BARRICADE, WITH FLASHING MONODIRECTIONAL LIGHTS
- ⊞ SIGN
- ↑ ARROW BOARD

MODEL: Default
 FILE NAME: p:\pub\lhammon.dwg
 PROJECT: 7199A\CAADDATA\CADD\projects\7199A\ch-4\m.dgn
 OFFICE: DISTRICT 7
 PLOT SCALE: 1/22/2021

**STATE OF ILLINOIS
DEPARTMENT OF TRANSPORTATION**

STAGE 2 TRAFFIC CONTROL

SCALE: SHEET OF 7 SHEETS STA. TO STA.

F.A.P. RTE.	SECTION	COUNTY	TOTAL SHEETS	SHEET NO.
320	D7 BRIDGE REPAIRS 2021-7	MACON	33	15
ILLINOIS FED. AID PROJECT			CONTRACT NO. 77994	

EXISTING STRUCTURE: SN 058-0020, built in 1956, is a 3 span bridge carrying U.S. 36 over lake Decatur. The proposed project consists of replacement of the expansion joints with new strip seals, bearing replacement at abutments with new elastomeric bearings, steel beam structure repair, curb repair, parapet repair, full depth deck patching, scarification & concrete overlay.

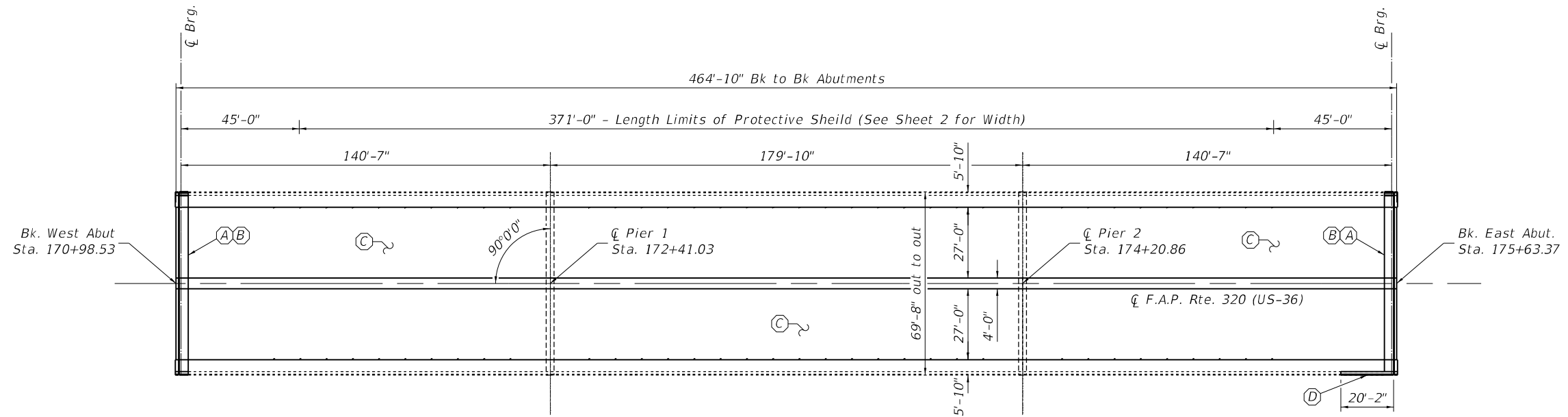
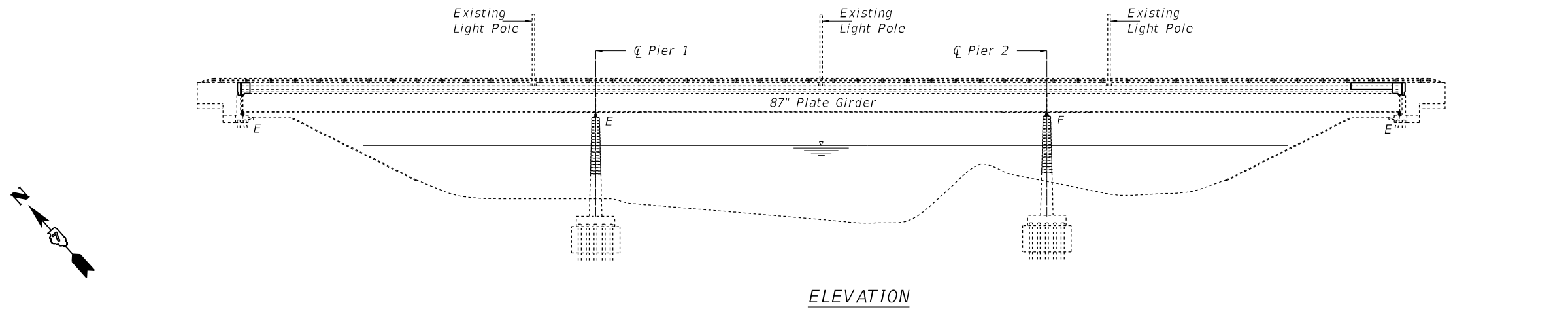

Expires 11-30-2022

David Carl Puzey

03/08/2021

- (A) - Remove and Replace Existing Strip Seal Expansion Joint
- (B) - Remove Existing Abutment Bearings and Install new Elastomeric Bearings & Structural Steel Repair
- (C) - Bridge Deck Scarification, 2-1/4", Deck Patching, & Bridge Deck Fly Ash or GGBF Slag Concrete Overlay, 2-1/4"
- (D) - Remove and Replace Parapet

**STATE OF ILLINOIS
DEPARTMENT OF TRANSPORTATION**

**GENERAL PLAN & ELEVATION
S.N. 058-0020**

SCALE: SHEET 1 OF 13 SHEETS STA. TO STA.

F.A.P. RTE.	SECTION	COUNTY	TOTAL SHEETS	SHEET NO.
320	D7 BRIDGE REPAIRS 2021-7	MACON	33	16
CONTRACT NO. 74994				
ILLINOIS FED. AID PROJECT				

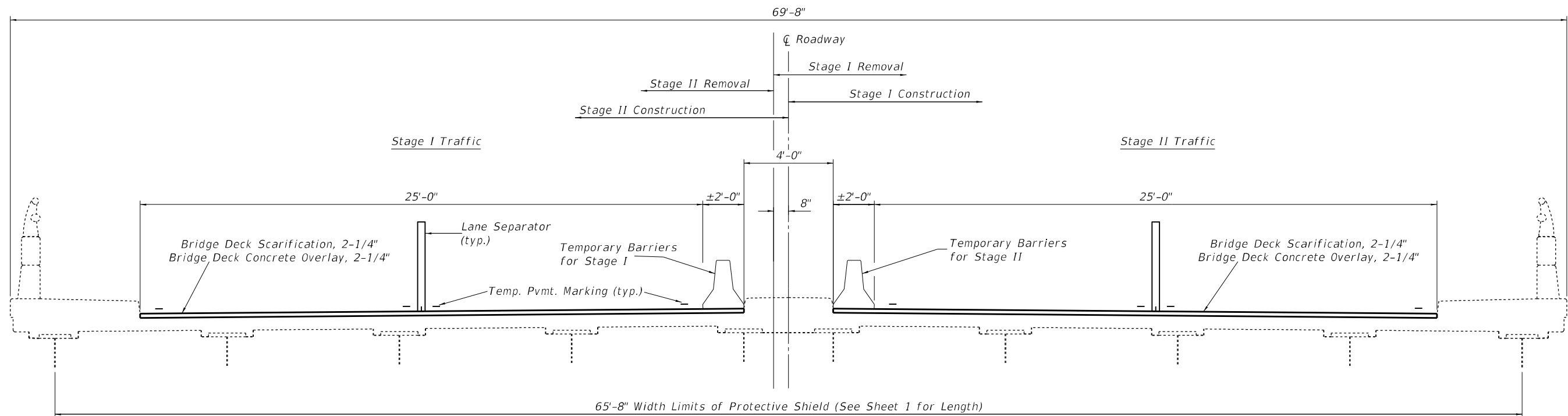

STAGE CONSTRUCTION DETAIL

Looking East

GENERAL NOTES

Plan dimensions and details relative to existing plans are subject to nominal construction variations. The Contractor shall field verify existing dimensions and details affecting new construction and make necessary approved adjustments prior to construction or ordering of materials. Such variations shall not be cause for additional compensation for a change in scope of the work, however, the Contractor will be paid for the quantity actually furnished at the unit price bid for the work.

Reinforcement Bars designated (E) shall be epoxy coated.

Existing reinforcement bars extending into the removal area shall be cleaned, straightened and incorporated into the new construction. Any reinforcement bars that are damaged during concrete removal operations shall be replaced with an approved bar splicer or anchorage system. Cost included with CONCRETE REMOVAL.

Joint openings shall be adjusted according to Article 520.04 of the Standard Specifications when the deck is poured at an ambient temperature other than 50 °F.

Removal and reinstallation of the handrail sections and support posts at both abutments will be necessary for construction of the expansion joints and parapet repair. The existing handrail sections and support posts shall be reused. New bolts, shim plates and post support anchor assemblies, as detailed in the plans, are to be provided and installed for the replacement of the handrail sections. This work and all materials shall be included in the contract unit price for CONCRETE SUPERSTRUCTURE.

All aluminum rail sections, rail posts, and connectors should be reused. Any new fasteners, shall be stainless steel. The contractor shall provide new, stainless steel anchors for connecting the rail post to the parapet. This work and the required materials shall be included in the contract unit price for CONCRETE SUPERSTRUCTURE.

Removal and reinstallation of the guardrail will be necessary for construction of the expansion joints. The existing guardrail sections shall be reused. All embedded anchors that are within the concrete removal area shall be cleaned and incorporated in the new construction or new approved alternatives shall be supplied and installed. This work and all materials shall be included in the contract unit price for CONCRETE SUPERSTRUCTURE.

All structural steel shall conform to AASHTO Classification M-270 Gr. 36, unless otherwise noted.

Protective Coat to be applied to areas of new concrete only, including bridge deck concrete overlay

Full depth deck slab repairs performed in the exterior bays of the bridge deck (between the parapet walls and the first interior beams) shall be limited to individual lengths no greater than 10'. In these portions of the deck, repair areas longer than 10' shall be divided into segments not greater than 10' in length, and the segments shall be poured in alternating sequence. Subsequent segments repaired in sequence shall not be removed until 72 hours shall have elapsed from the end of the previous, adjacent pour, and the adjacent pour shall have attained a minimum modulus of rupture of 650psi.

Prior to pouring the new concrete deck, all heavy or loose rust, loose mill scale, and other loose or potentially detrimental foreign material shall be removed from the surfaces in contact with concrete. Tightly adhered paint may remain unless otherwise noted. Removal shall be accomplished by methods that will not damage the steel and the cost will be included in the pay item covering removal of the existing concrete.

Areas of deck repairs shown are estimated. The Engineer shall show actual locations of deck repairs on as-built plans.

It shall be the responsibility of the utility company/agency to support and protect their facility during construction. The Contractor shall notify each of the following at least two weeks prior to beginning construction.

Ameren IP
Kevin Verhofstad
(217) 424-8278 (O)
(217) 358-9228 (C)
Email: Kverhofstad@ameren.com

City Highway Lighting
Paul Caswell (City Engineer)
(217) 424 2747 (O)
(217) 424-2799 (C)
Email: pcaswell@decaturl.gov

Decatur Sanitary District
Don Miller
(217) 422-6931 Ext: 216 (O)

AT&T
Mike Murphy
(217) 398-7979 (O)
Email: mm2926@att.com

TOTAL BILL OF MATERIAL

ITEM	UNIT	QUANTITY
Concrete Removal	CU. YD.	33
Concrete Superstructure	CU. YD.	33
Reinforcement Bars, Epoxy Coated	Pound	6250
Bridge Deck Grooving	SQ. YD.	2568
Bridge Deck Scarification, 2-1/4"	SQ. YD.	2,733
Bridge Deck Fly Ash or GGBF Slag Concrete Overlay, 2-1/4"	SQ. YD.	2,733
Preformed Joint Strip Seal	Foot	136
Protective Coat	SQ. YD.	2,815
Bar Splicers	Each	44
Jack & Remove Existing Bearings	Each	20
Elastomeric Bearing Assembly, Type I	Each	10
Elastomeric Bearing Assembly, Type II	Each	10
Anchor Bolts, 1"Ø	Each	40
Furnishing and Erecting Structural Steel	Pound	5220
Structural Steel Repair	Pound	1380
Deck Slab Repair (Full Depth, Type I)	SQ. YD.	22
Deck Slab Repair (Full Depth, Type II)	SQ. YD.	137
Structural Repair of Concrete (Depth ≤ 5")	SQ. FT.	425
Protective Shield	SQ. YD.	2,707

**STATE OF ILLINOIS
DEPARTMENT OF TRANSPORTATION**

**STAGING, GENERAL NOTES, &
BILL OF MATERIAL**

F.A.P. RTE.	SECTION	COUNTY	TOTAL SHEETS	SHEET NO.
320	D7 BRIDGE REPAIRS 2021-7	MACON	33	17
CONTRACT NO. 74994				
ILLINOIS FED. AID PROJECT				

SCALE: SHEET 2 OF 13 SHEETS STA. TO STA.

MODEL: Default
 FILE NAME: p:\data\amaron.dwg
 PROJECT: 74994\CAD\DATA\CAD\PROJECTS\74994-CP-058-0020 - Deck Repair.dwg

For Sections A-A, B-B, C-C, & D-D,
See Sheet 5 of 13

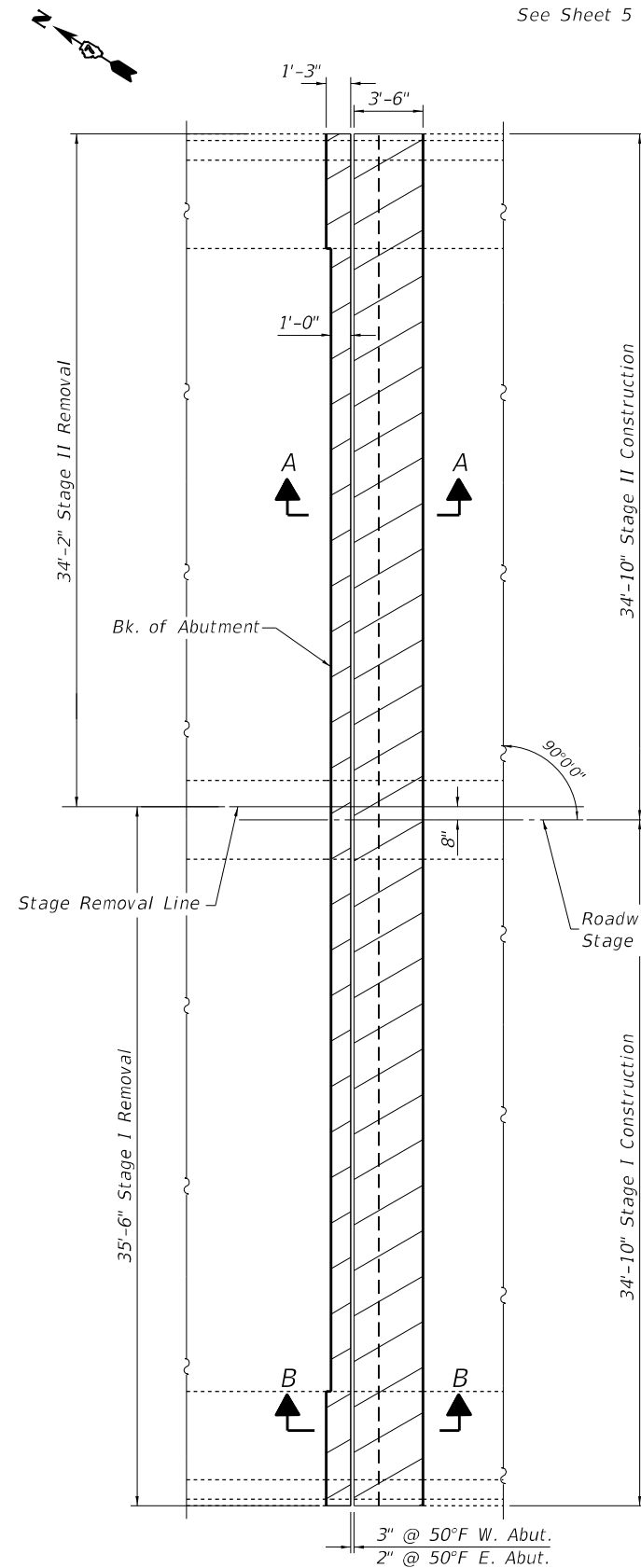

REMOVAL PLAN
West Abutment Shown
East Abutment Similar

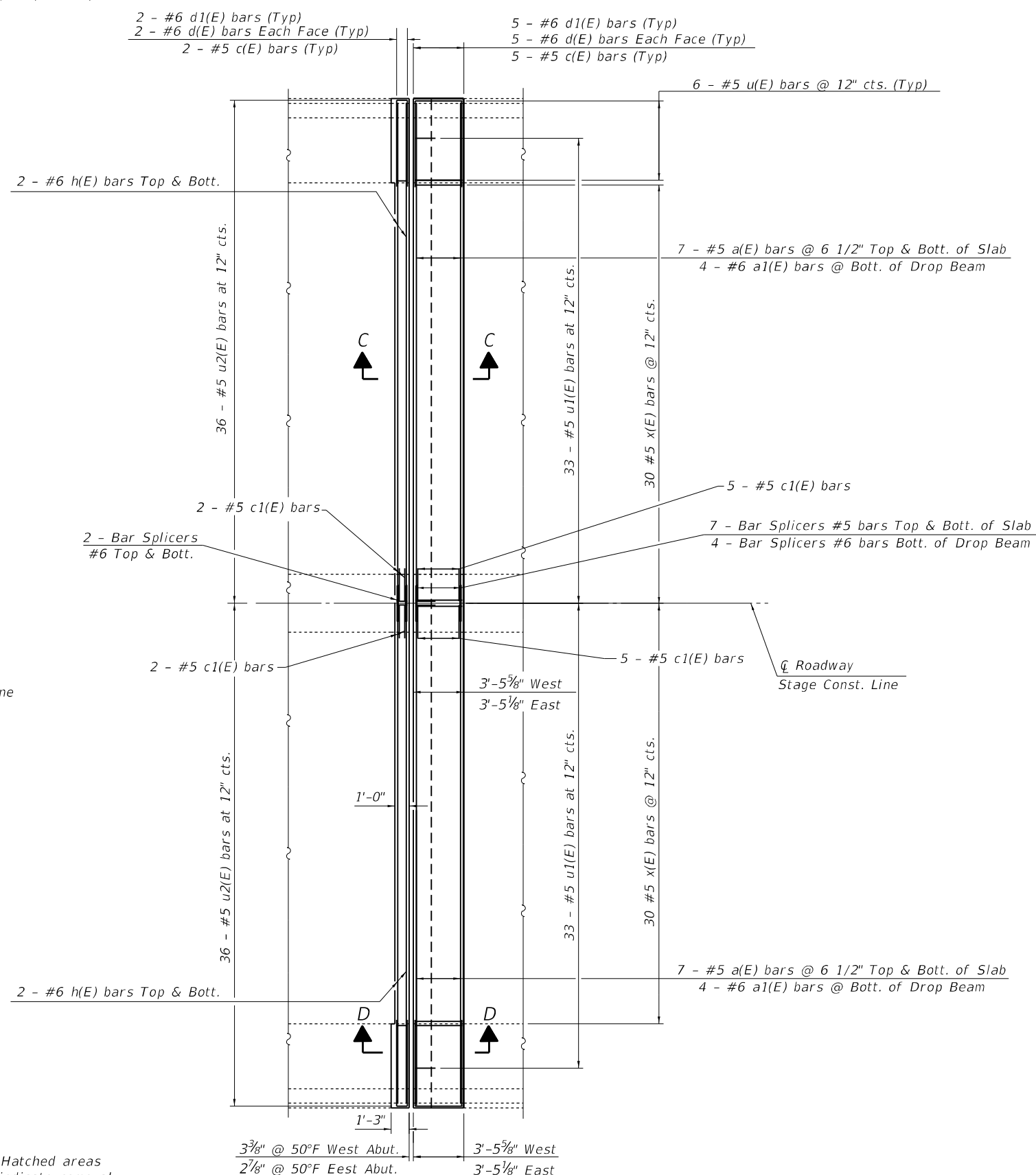

REINFORCEMENT PLAN
West Abutment Shown
East Abutment Similar

Note: Hatched areas indicate removal

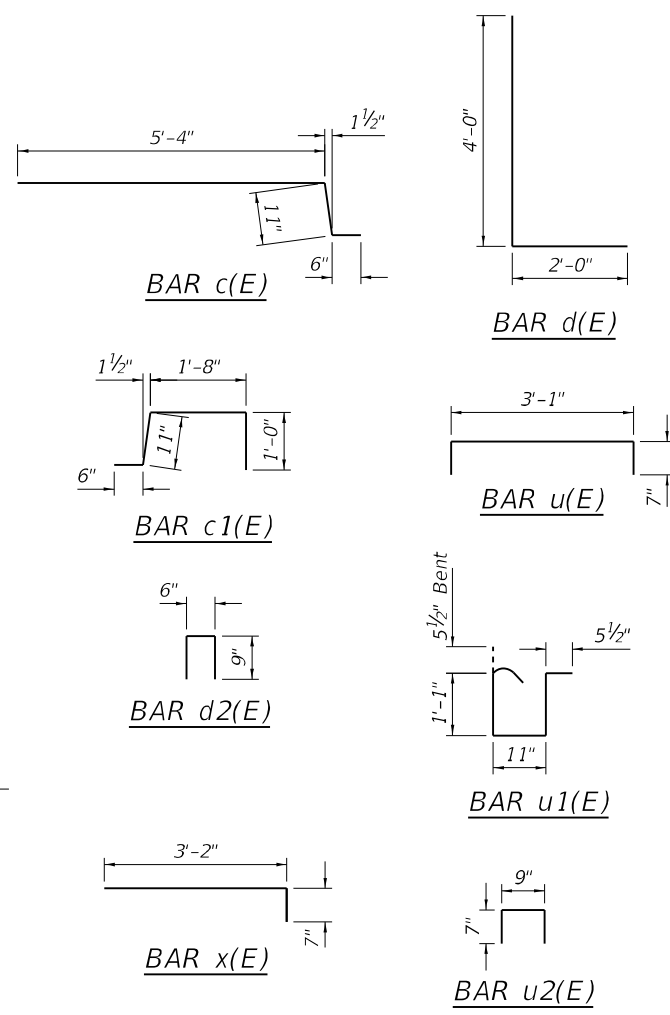

BILL OF MATERIAL

Bar	No.	Size	Length	Shape
a(E)	56	#5	34'-5"	—
a1(E)	16	#6	32'-6"	—
c(E)	28	#5	6'-9"	┌
c1(E)	28	#5	4'-1"	┌
d(E)	56	#6	6'-0"	┌
d1(E)	45	#4	2'-0"	┌
d2(E)	34	#6	3'-5"	—
e(E)	8	#5	19'-10"	—
h(E)	16	#6	34'-0"	—
u(E)	24	#5	4'-3"	┌
u1(E)	132	#5	4'-0"	┌
u2(E)	144	#5	1'-11"	┌
x(E)	120	#5	3'-9"	┌
ITEM UNIT QUANTITY				
Concrete Removal			Cu. Yd.	33
Concrete Superstructure			Cu. Yd.	33
Reinforcement Bars, Epoxy Coated			Pound	6250
Bar Splicers			Each	44

MODEL: Default
 FILE: M:\MIS\Projects\2021\74994\Drawings\2021-74994-058-0020 Deck Repairs.dwg
 PROJECT: 2021-74994\Drawings\2021-74994-058-0020 Deck Repairs.dwg
 OFFICE: District 7
 DATE: 1/22/2021

USER NAME = steffemk	DESIGNED - T. Walk	REVISED -
DRAWN - T. Walk	REVISED -	
PLOT SCALE = 100,0000' / in.	CHECKED - D. Macklin	REVISED -
PLOT DATE = 1/22/2021	DATE - May 2020	REVISED -

**STATE OF ILLINOIS
DEPARTMENT OF TRANSPORTATION**

**EXPANSION JOINT REPLACEMENT DETAILS
S.N. 058-0020**

SCALE: SHEET 3 OF 13 SHEETS STA. TO STA.

F.A.P. RTE.	SECTION	COUNTY	TOTAL SHEETS	SHEET NO.
320	D7 BRIDGE REPAIRS 2021-7	MACON	33	18
CONTRACT NO. 74994			ILLINOIS FED. AID PROJECT	

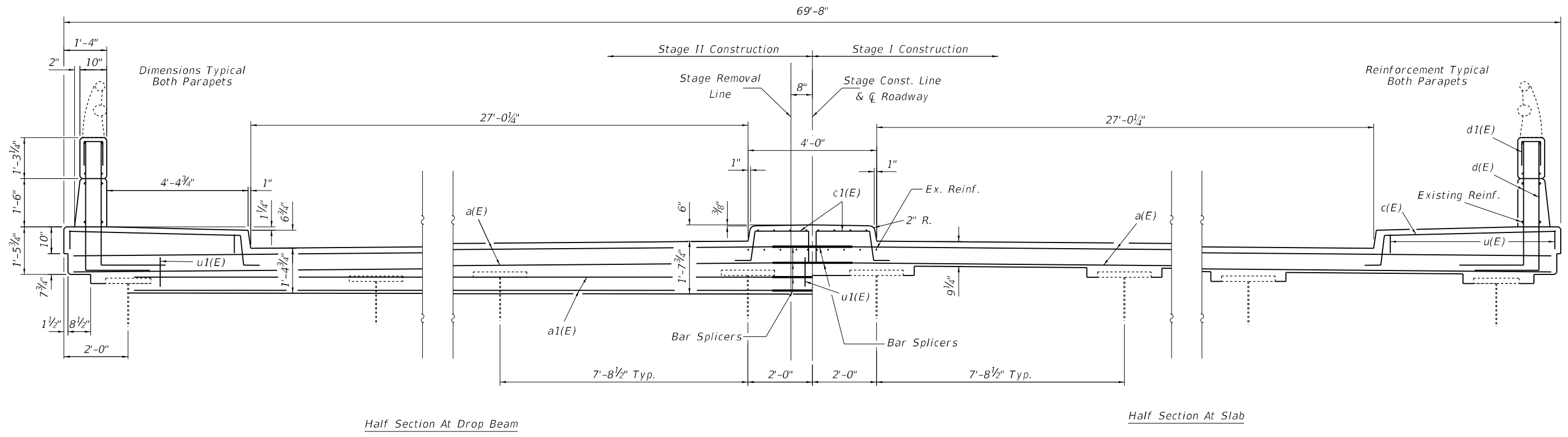

SECTION THRU END OF DECK
Looking East

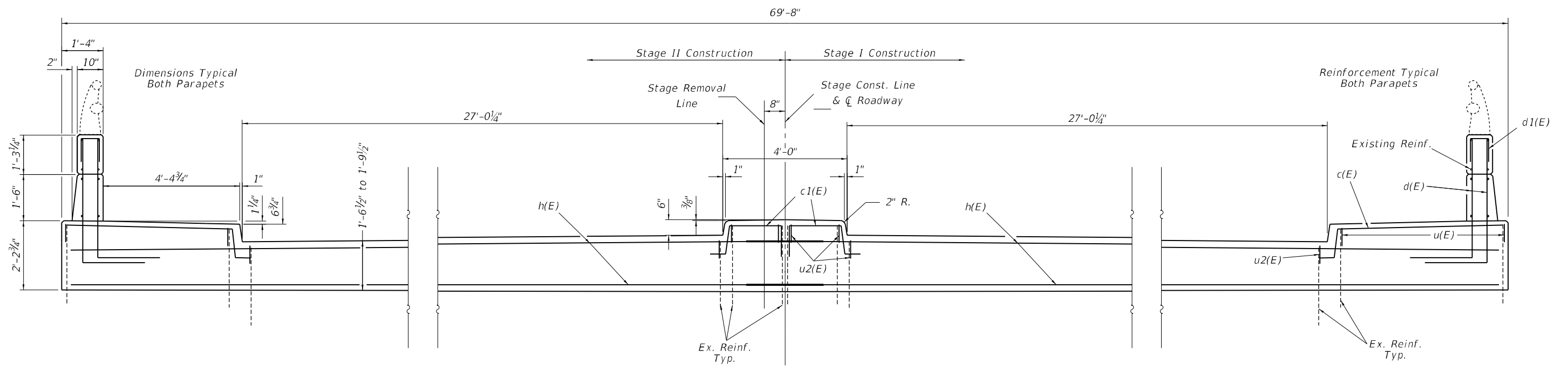

SECTION THRU ABUTMENT AT JOINT
Looking East

MODEL: Default
 FILE NAME: p:\work\74994\CADD\Drawings\DOT_Offices\Drawings\74994\Drawings\058-0020_Deck_Repairs.dwg
 PROJECT: 74994\CADD\Drawings\DOT_Offices\Drawings\74994\Drawings\058-0020_Deck_Repairs.dwg

USER NAME = stefenmk	DESIGNED - T. Walk	REVISED -
DRAWN - T. Walk	REVISED -	
PLOT SCALE = 100,0000' / in.	CHECKED - D. Macklin	REVISED -
PLOT DATE = 1/22/2021	DATE - May 2020	REVISED -

STATE OF ILLINOIS
DEPARTMENT OF TRANSPORTATION

EXPANSION JOINT REPLACEMENT DETAILS
S.N. 058-0020

SCALE: SHEET 4 OF 13 SHEETS STA. TO STA.

F.A.P. RTE.	SECTION	COUNTY	TOTAL SHEETS	SHEET NO.
320	D7 BRIDGE REPAIRS 2021-7	MACON	33	19
CONTRACT NO. 74994				
ILLINOIS FED. AID PROJECT				

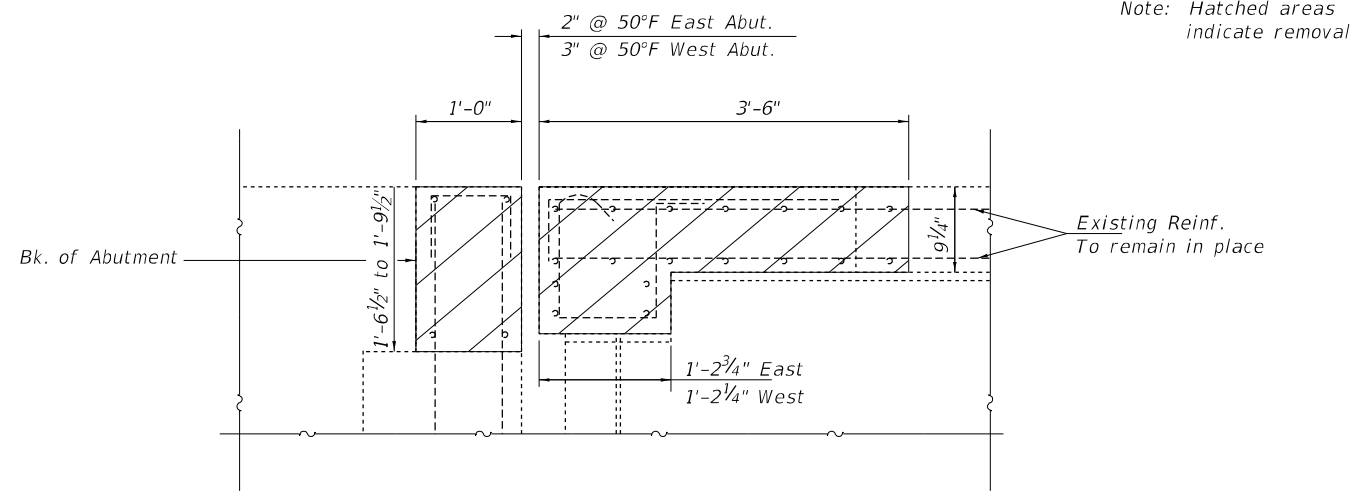

SECTION A-A

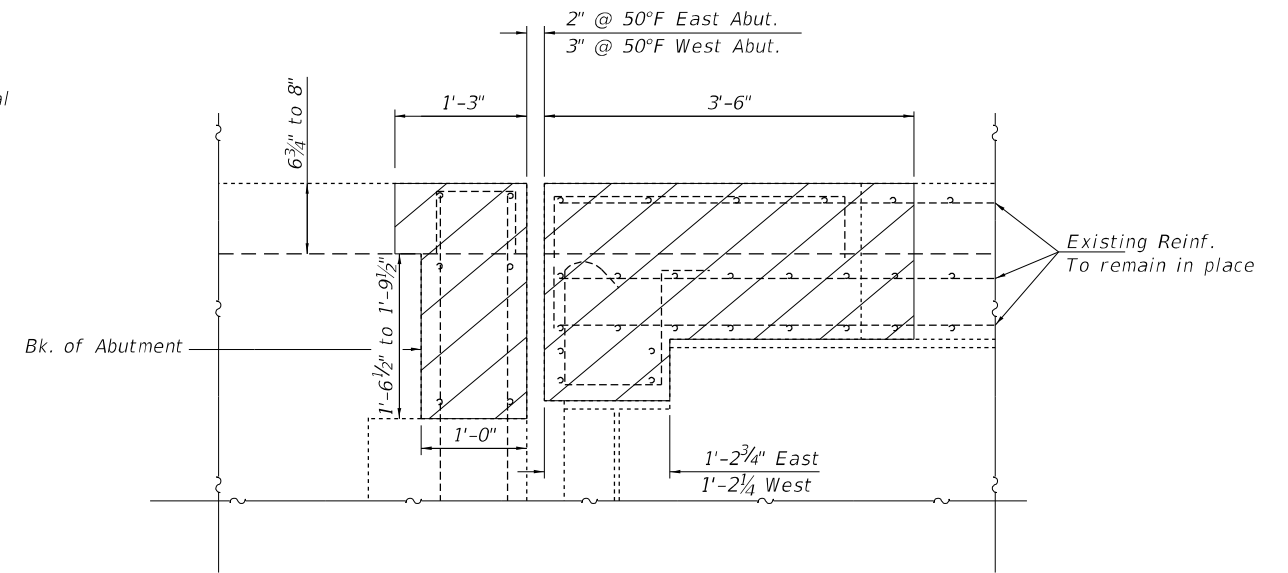

SECTION B-B

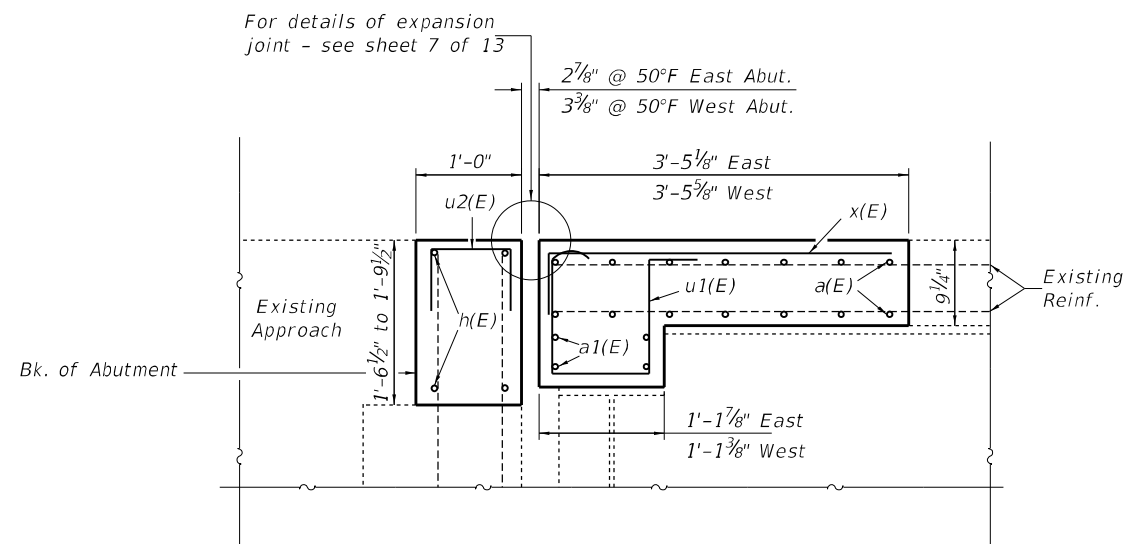

SECTION C-C

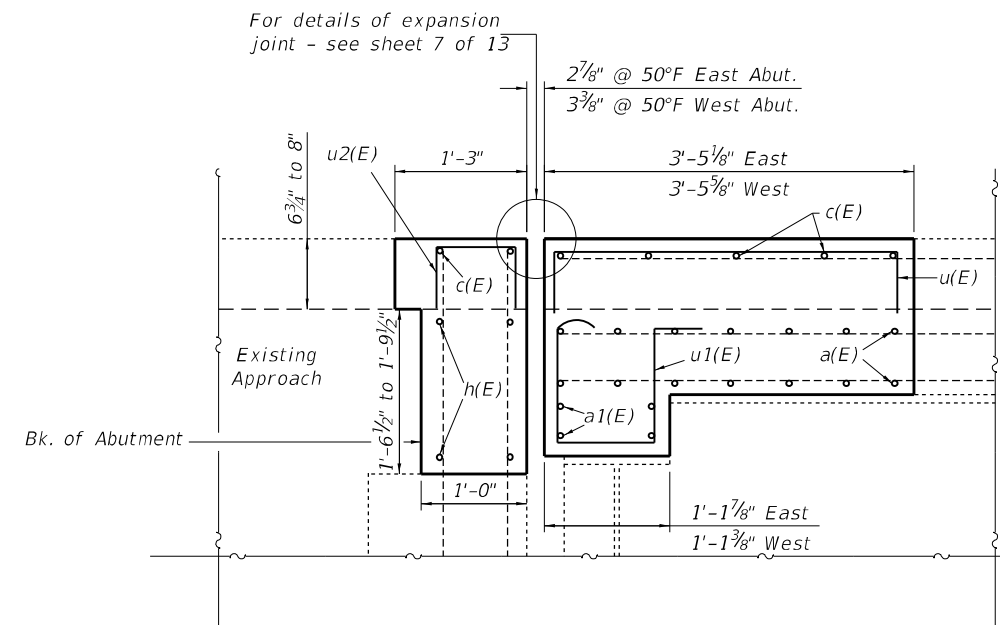

SECTION D-D

MODEL: Default
 FILE NAME: p:\pub\harronm.dwt
 PROJECT: 74994\CAD\Drawings\DOT - Office\Drawings\74994\74994-058-0020 - Deck Repairs.dwg

USER NAME = steffennk	DESIGNED - T. Walk	REVISED -
	DRAWN - T. Walk	REVISED -
PLOT SCALE = 100,0000' / in.	CHECKED - D. Macklin	REVISED -
PLOT DATE = 1/22/2021	DATE - May 2020	REVISED -

STATE OF ILLINOIS
DEPARTMENT OF TRANSPORTATION

EXPANSION JOINT REPLACEMENT DETAILS
S.N. 058-0020

SCALE: SHEET 5 OF 13 SHEETS STA. TO STA.

F.A.P. RTE.	SECTION	COUNTY	TOTAL SHEETS	SHEET NO.
320	D7 BRIDGE REPAIRS 2021-7	MACON	33	20
ILLINOIS FED. AID PROJECT			CONTRACT NO. 74994	

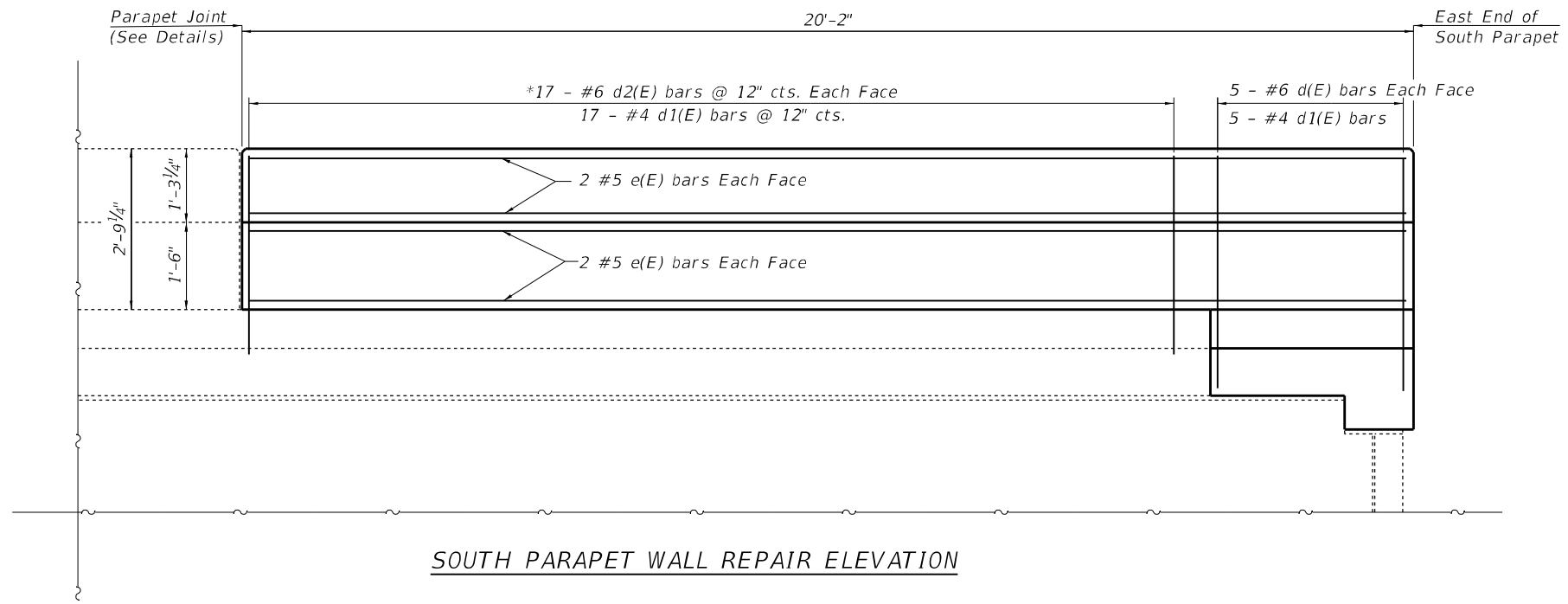

SOUTH PARAPET WALL REPAIR ELEVATION

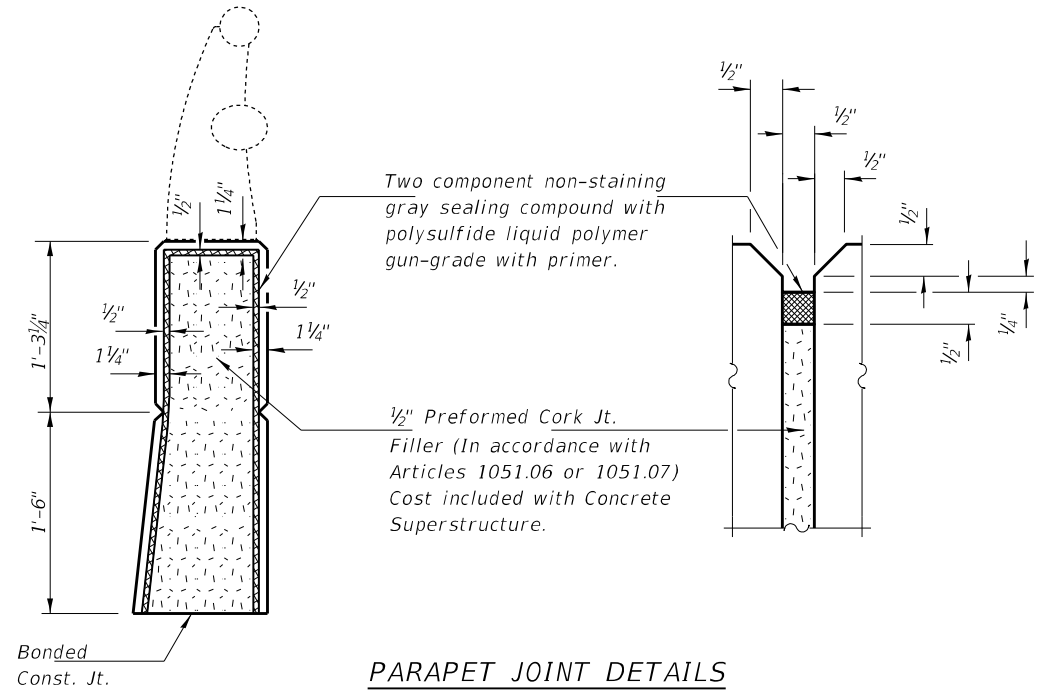

PARAPET JOINT DETAILS

* Epoxy grout d2(E) bars in 10" min. holes according to Article 584 of Standard Spec.

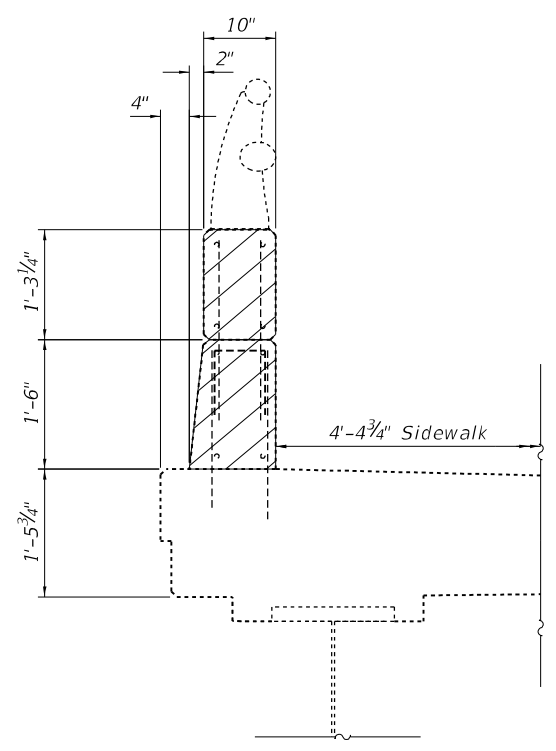

PARAPET REMOVAL SECTION

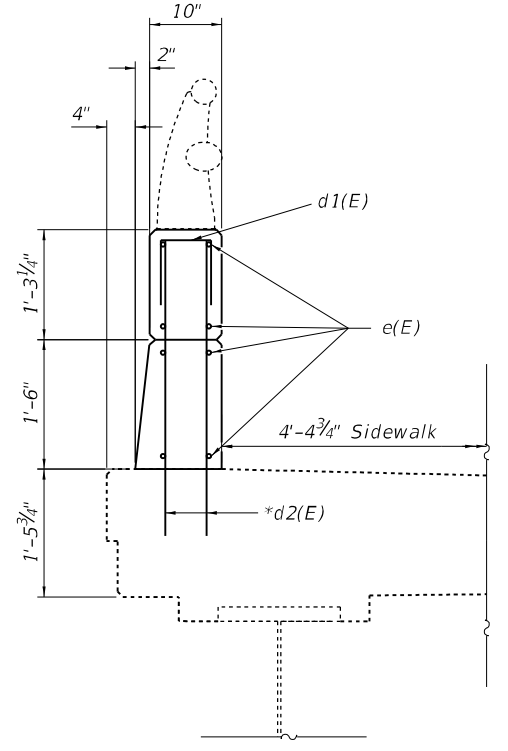

PROPOSED PARAPET SECTION

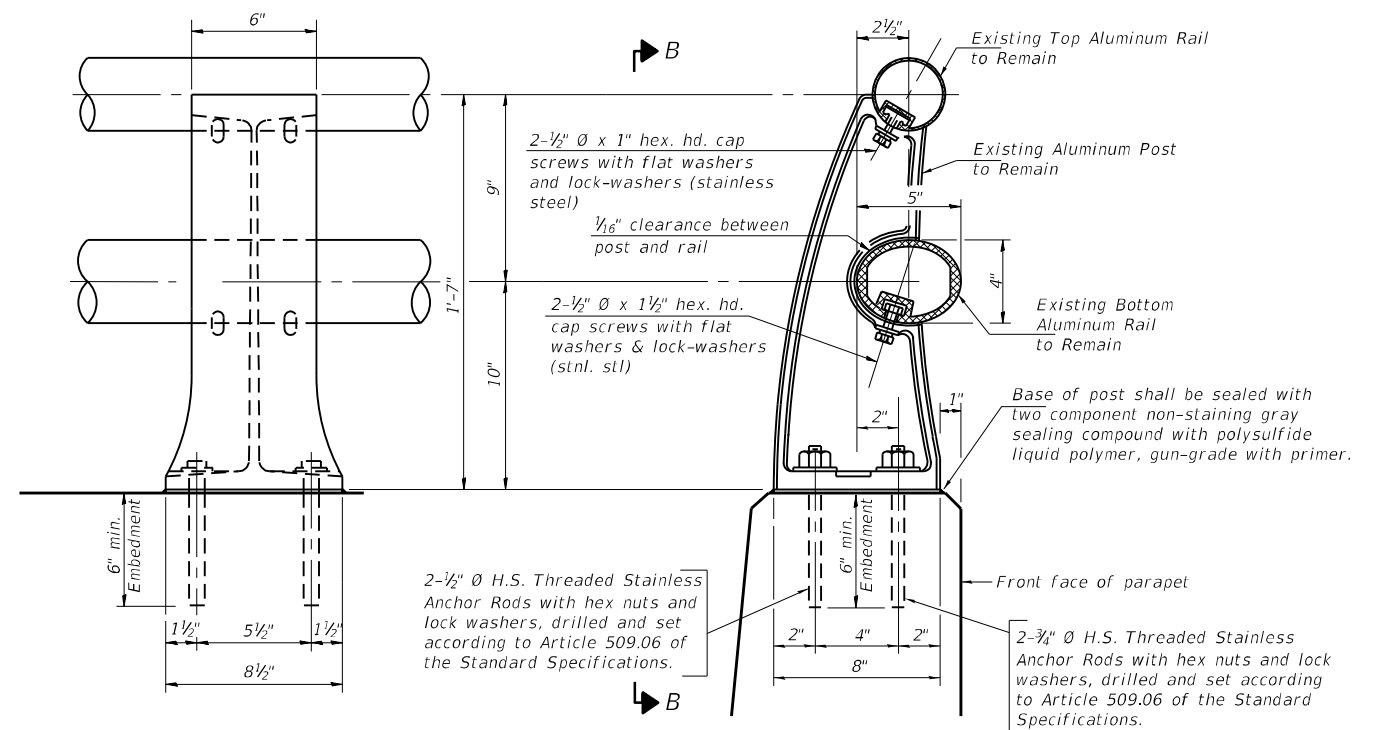

VIEW B-B

SECTION A-A

RAIL POST DETAILS

MODEL: Default
 FILE NAME: p:\pub\baronm.dwg
 PROJECT: 7499A\CADD\DATA\CADD\PROJECTS\7499A\4-15-20\058-0020_Deck_Repairs.dwg

USER NAME = stefienmk	DESIGNED - T. Walk	REVISED -
DRAWN - T. Walk	REVISED -	
PLOT SCALE = 100,0000' / in.	CHECKED - D. Macklin	REVISED -
PLOT DATE = 1/22/2021	DATE - May 2020	REVISED -

**STATE OF ILLINOIS
DEPARTMENT OF TRANSPORTATION**

**PARAPET REPAIR DETAILS & RAIL POST DETAILS
S.N. 058-0020**

SCALE: SHEET 6 OF 13 SHEETS STA. TO STA.

F.A.P. RTE.	SECTION	COUNTY	TOTAL SHEETS	SHEET NO.
320	D7 BRIDGE REPAIRS 2021-7	MACON	33	21
CONTRACT NO. 7499A			ILLINOIS FED. AID PROJECT	

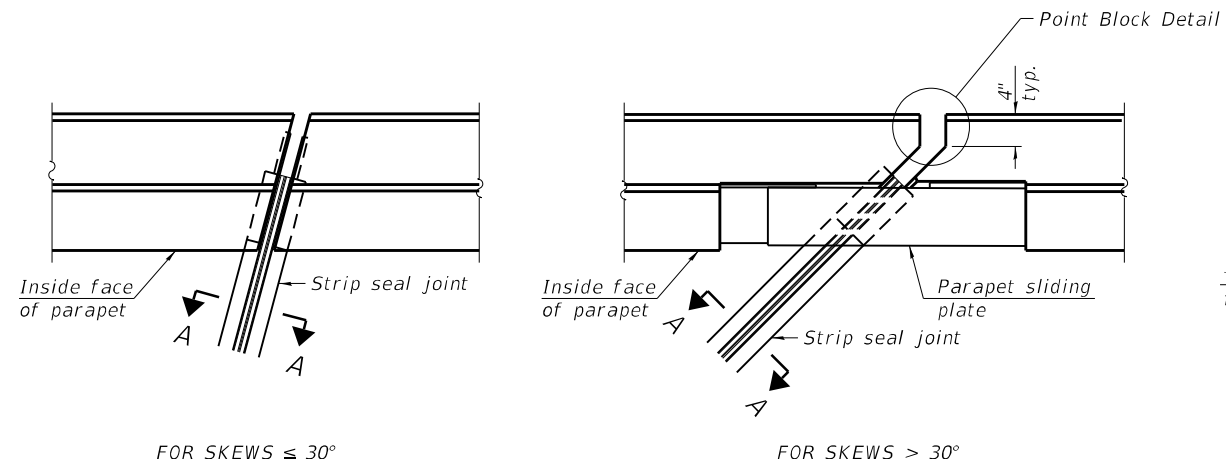

PLAN AT PARAPET

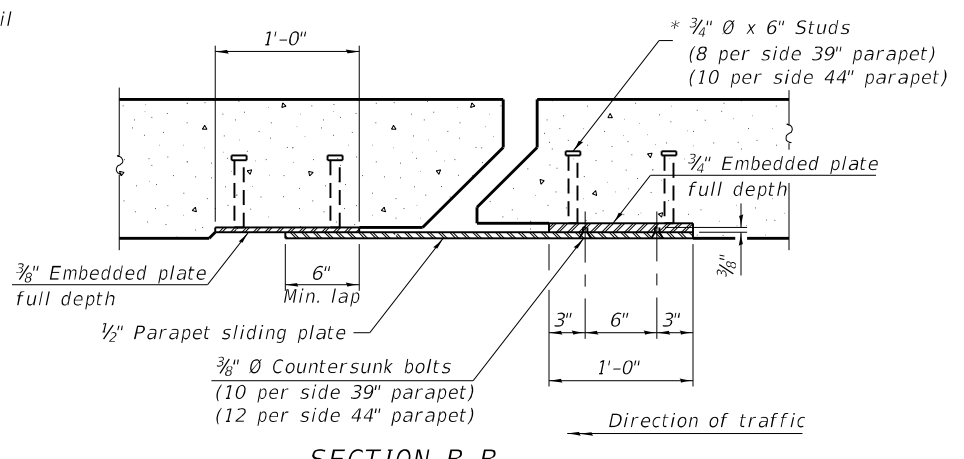

SECTION B-B

Notes:

The strip seal shall be made continuous and shall have a minimum thickness of 1/4". The configuration of the strip seal shall match the configuration of the locking edge rails. Open or "webbed" strip seal gland configurations are not permitted. The gland shall be sized for a maximum rated movement of 4 inches.

The locking edge rails depicted are configured for typical applications and are conceptual only. The actual configuration of the locking edge rails and matching strip seal may vary from manufacturer to manufacturer provided they fit the application and meet the minimum anchorage shown. Flanged edge rails, however, will not be allowed. Locking edge rails may exceed the 4 1/2" maximum depth provided the anchorage system is revised according to the manufacturer's recommendation.

The manufacturer's recommended installation methods shall be followed.

All steel components shall be galvanized after fabrication according to Article 520.03 of the Standard Specifications.

The Maximum space between locking edge rail segments shall be 3/16" and sealed with a suitable sealant; however, any rail joint within 10' measured perpendicular to the face of the curb or parapet shall be welded as shown in the locking edge rail splice detail.

The top surface of sidewalk sliding plates shall have a raised pattern according to ASTM A786.

Cost of parapet sliding plates, sidewalk sliding plates, embedded plates, anchorage studs, and expansion anchors included with Preformed Joint Strip Seal.

39" constant slope barrier shown, 44" constant slope barrier similar as noted.

The concrete opening below the strip seal will vary based on the locking edge rail chosen by the Contractor. Deck and parapet lengths shown elsewhere in the plans are dimensioned to the concrete opening, not the joint opening, and are based on the rolled locking edge rail. If the Contractor elects to use a different locking edge rail, dimensional adjustments may be required. One exception to this would be the strip seal joint at the end of the precast bridge approach slab. For these cases the pavement connector length shall be adjusted, not the length of the bridge approach slab.

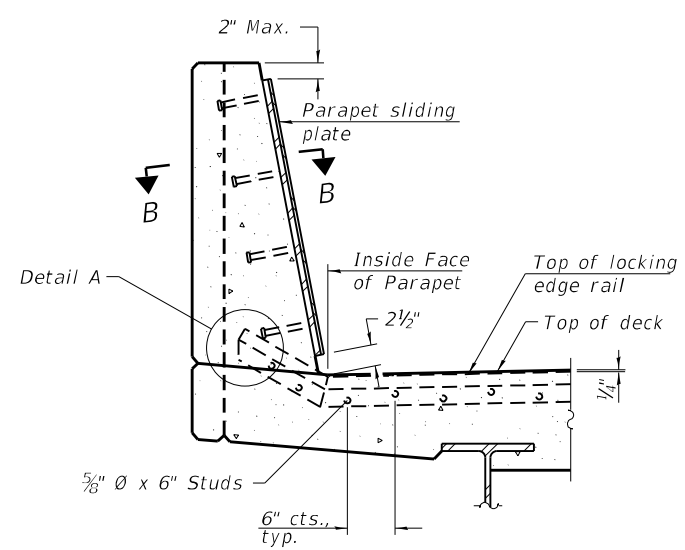

SECTION AT PARAPET

(Skews $> 30^\circ$ shown. Skews $\leq 30^\circ$ similar except as shown in plan view.)

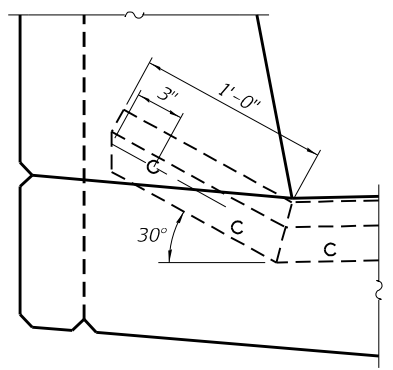

DETAIL A

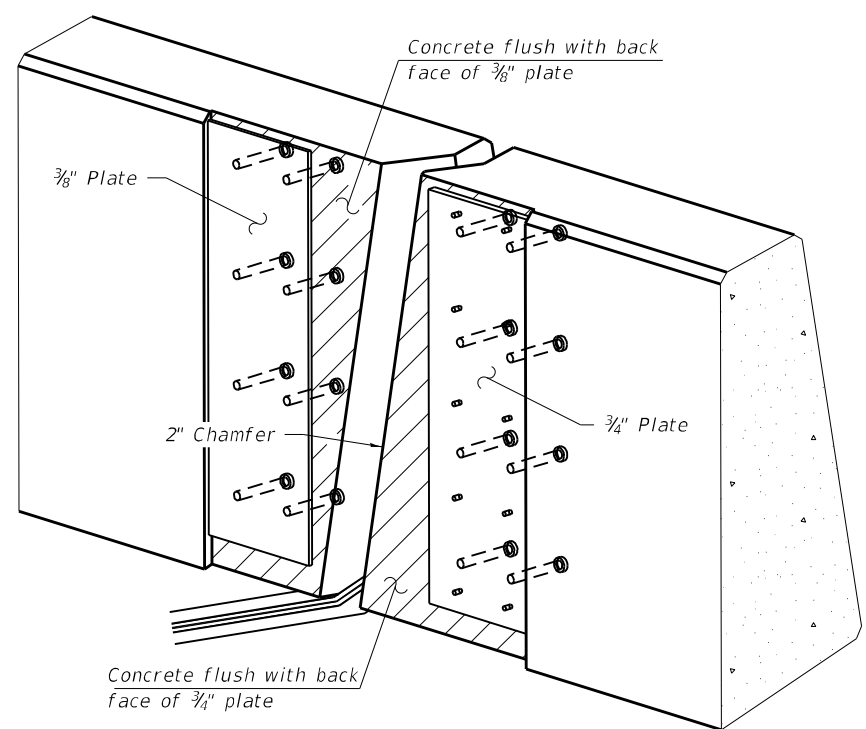

TRIMETRIC VIEW

(Showing embedded plates only)

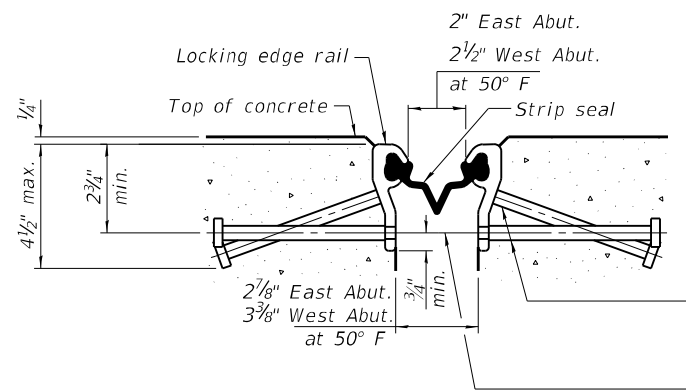

SHOWING ROLLED RAIL JOINT

* 3/8" \emptyset x 6" studs @ 6" cts. (alternate angled/bent studs with horizontal studs)

3/8" ϕ threaded rods in 1/16" ϕ holes at ± 4 -0" cts. for holding the proper joint opening based on the temperature during the deck pour. Place to miss studs. All rods shall be burned, or sawed off flush with the plates after concrete is set.

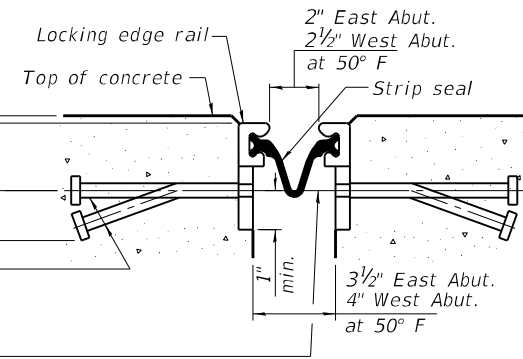

SHOWING WELDED RAIL JOINT

SECTION A-A

* Granular or solid flux filled headed studs conforming to Article 1006.32 of the Std. Specs., automatically end welded.

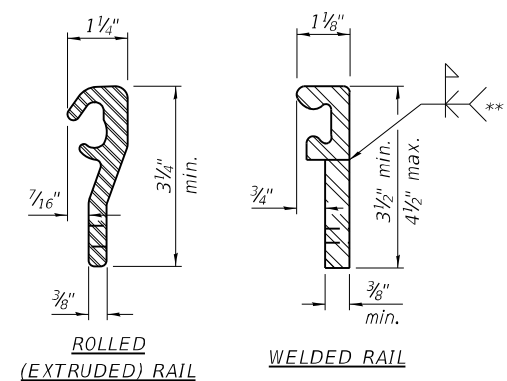

LOCKING EDGE RAILS

** Back gouge not required if complete joint penetration is verified by mock-up.

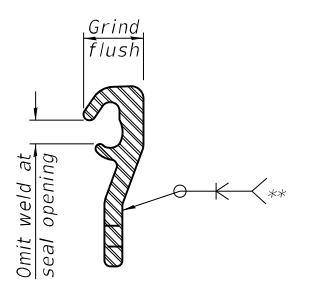

LOCKING EDGE RAIL SPLICE

The inside of the locking edge rail groove shall be free of weld residue. Rolled rail shown, welded rail similar.

BILL OF MATERIAL

Item	Unit	Total
Preformed Joint Strip Seal	Foot	136

EJ-SS-S

1-1-2020

(Sheet 1 of 3)

MODEL: Default
 FILE NAME: p:\pub\baronm.dwt
 PROJECT: 7499A\CADD\DATA\CAD\Drawings\7499A-058-0020 Deck Repairs.dwg
 OFFICE: DISTRICT 7
 PROJECT: 7499A\CADD\DATA\CAD\Drawings\7499A-058-0020 Deck Repairs.dwg

USER NAME = stefenmk	DESIGNED - T. Walk	REVISED -
PLOT SCALE = 100,0000' / in.	DRAWN - T. Walk	REVISED -
PLOT DATE = 1/22/2021	CHECKED - D. Macklin	REVISED -
	DATE - May 2020	REVISED -

**STATE OF ILLINOIS
DEPARTMENT OF TRANSPORTATION**

**PREFORMED JOINT STRIP SEAL - SIDEWALK
STRUCTURE NO. 058-0020**

SCALE: SHEET 7 OF 13 SHEETS STA. TO STA.

F.A.P. RTE.	SECTION	COUNTY	TOTAL SHEETS	SHEET NO.
320	D7 BRIDGE REPAIRS 2021-7	MACON	33	22
CONTRACT NO. 7499A				
ILLINOIS FED. AID PROJECT				

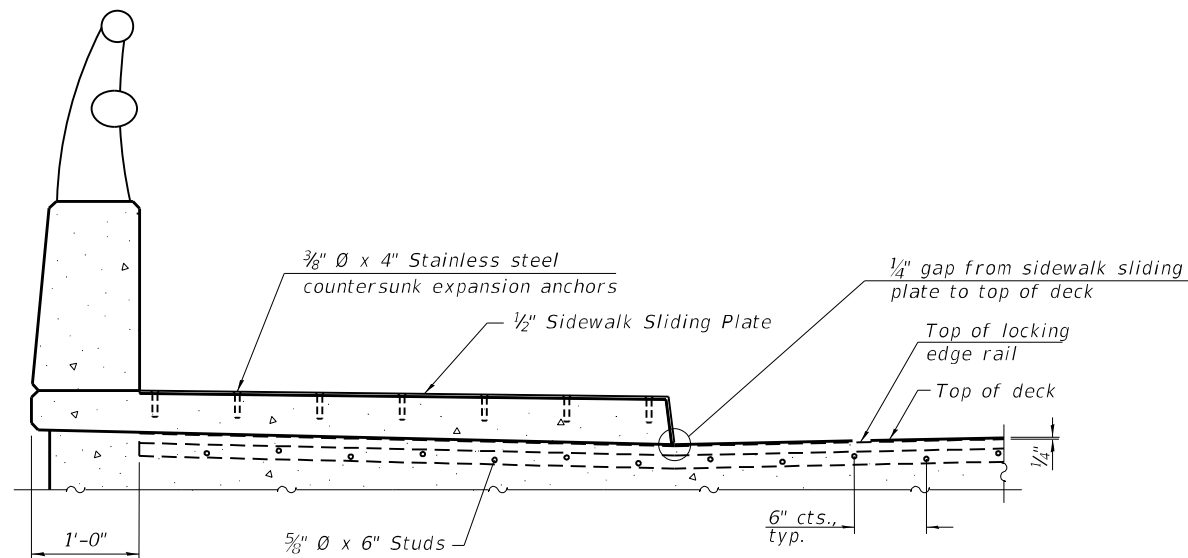

SECTION AT RAISED SIDEWALK

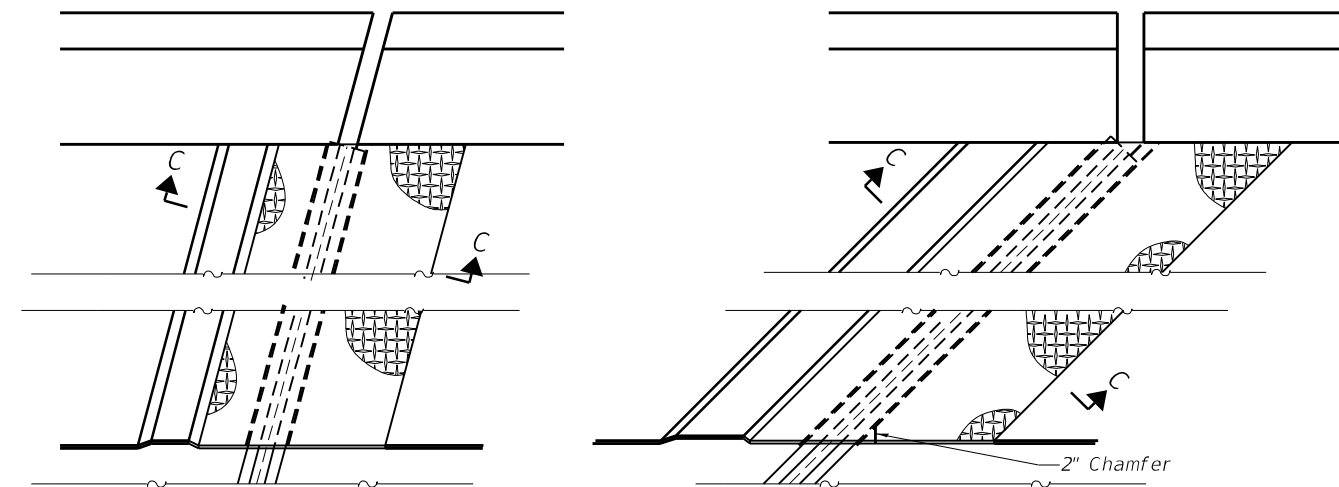

(FOR SKEWS $\leq 30^\circ$)

(FOR SKEWS $> 30^\circ$)

PLAN AT RAISED SIDEWALK

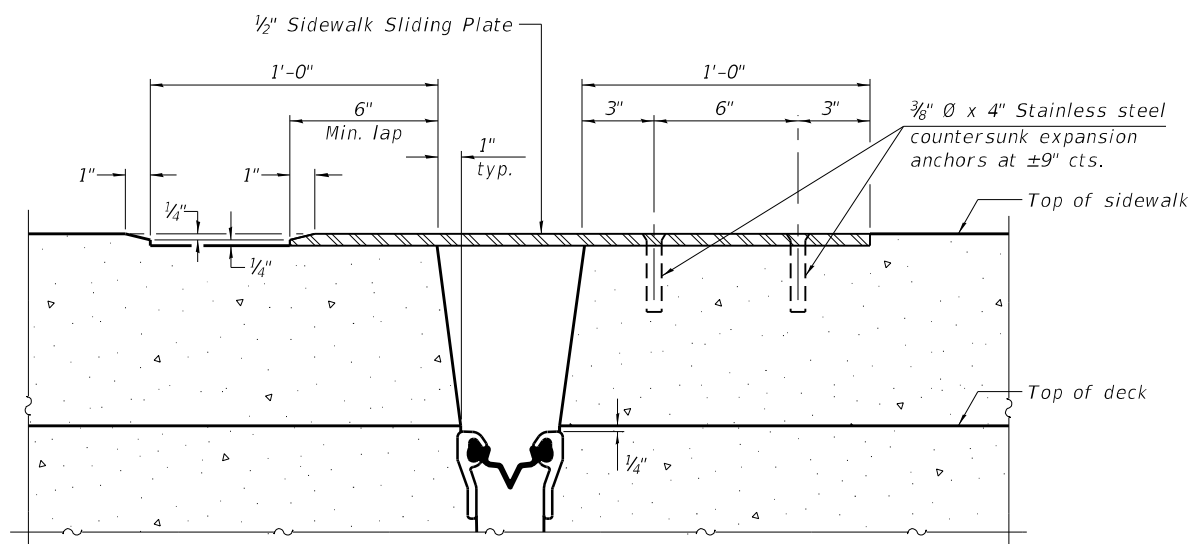

SECTION C-C

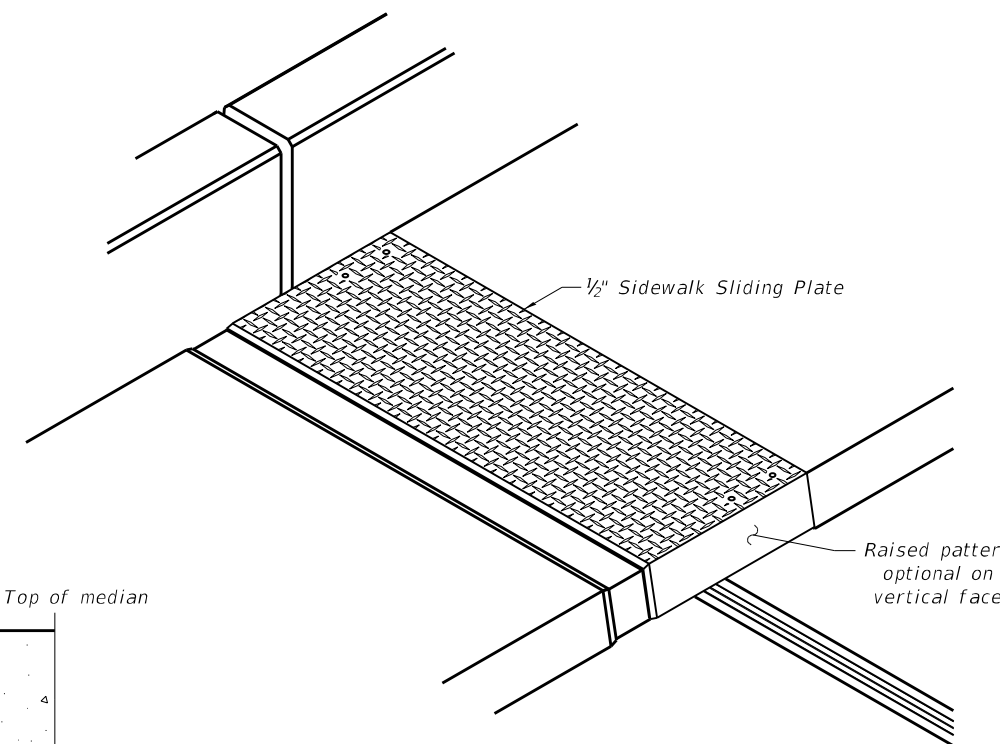

TRIMETRIC VIEW

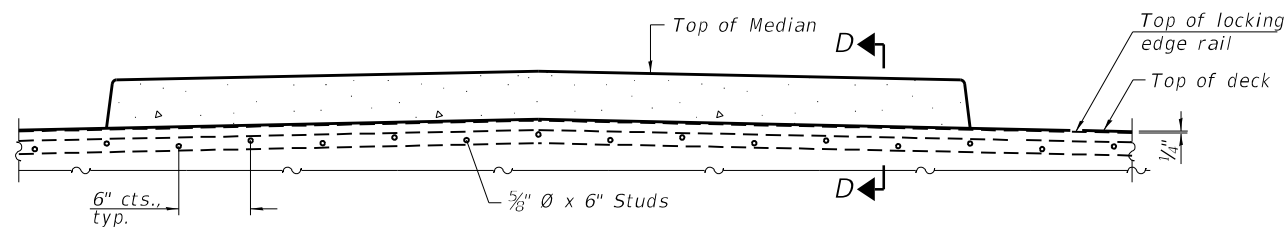

SECTION AT MEDIAN

For skews $> 30^\circ$, chamfer acute corners 2" similar to sidewalk.

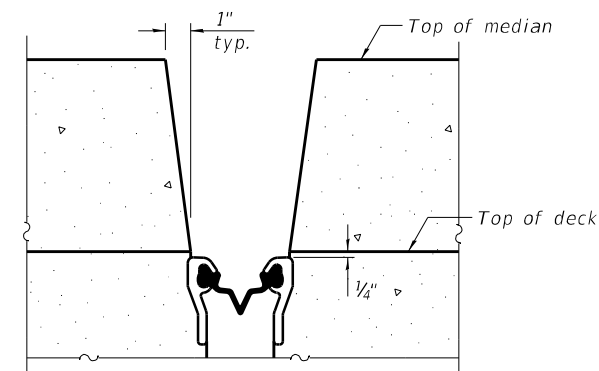

SECTION D-D
(at Rt. L's)

EJ-SS-S

1-1-2020

(Sheet 2 of 3)

STATE OF ILLINOIS
DEPARTMENT OF TRANSPORTATION

PREFORMED JOINT STRIP SEAL - SIDEWALK
STRUCTURE NO. 058-0020

USER NAME = steffemk	DESIGNED - T. Walk	REVISED -
PLOT SCALE = 100,0000' / in.	DRAWN - T. Walk	REVISED -
PLOT DATE = 1/22/2021	CHECKED - D. Macklin	REVISED -
	DATE - May 2020	REVISED -

SCALE: SHEET 8 OF 13 SHEETS STA. TO STA.

F.A.P. RTE.	SECTION	COUNTY	TOTAL SHEETS	SHEET NO.
320	D7 BRIDGE REPAIRS 2021-7	MACON	33	23
CONTRACT NO. 74994				
ILLINOIS FED. AID PROJECT				

MODEL: Default
 FILE NAME: p:\pub\baronm.dwt
 PROJECT: 74994\CADD\DATA\CADD\PROJECTS\058-0020_Deck_Repairs.dwg
 PLOT DATE: 1/22/2021

058-0020 West Span

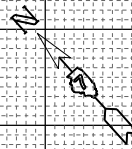

Bk. West Abut
Sta. 170+98.53

☉ Pier 1
Sta. 172+41.03

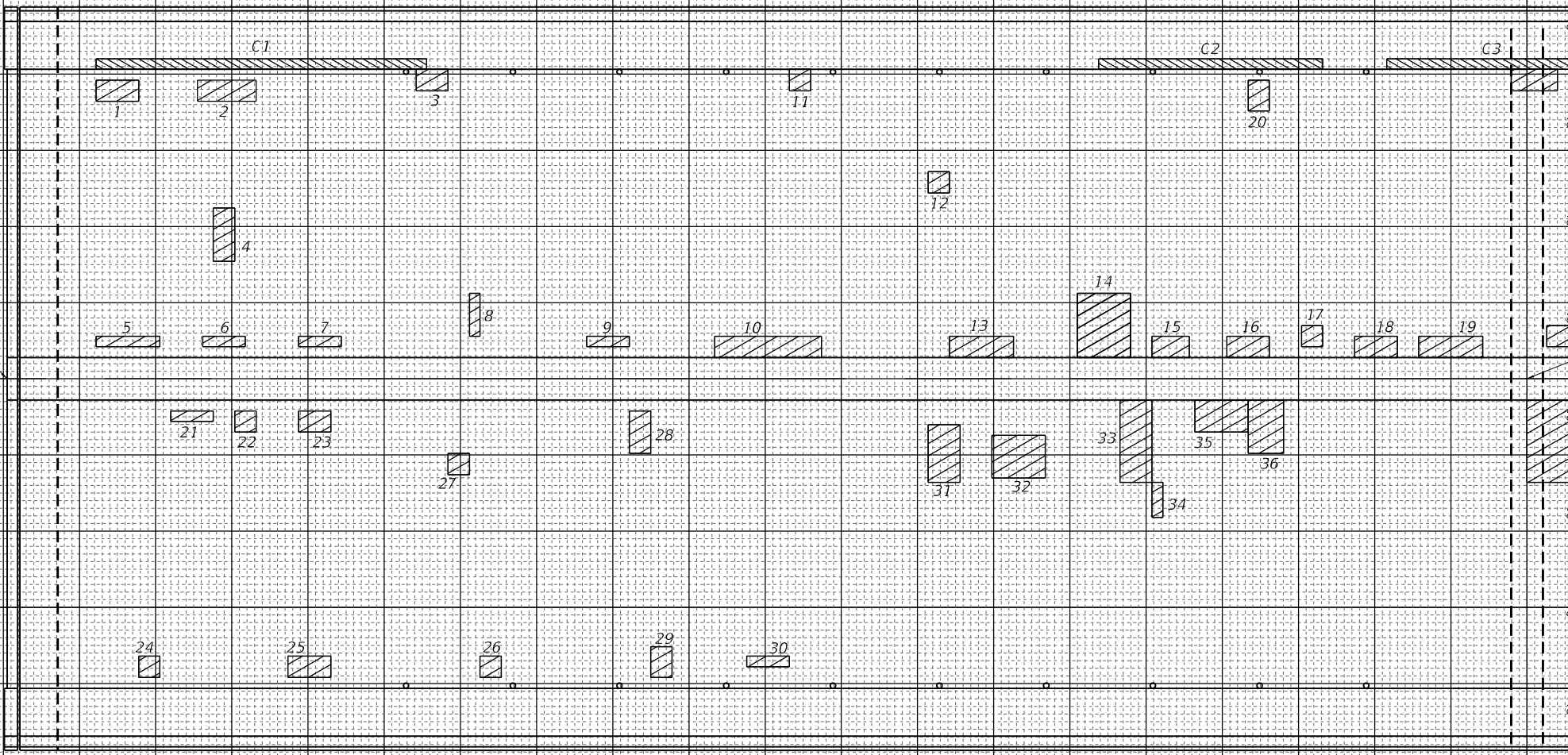

PATCH NO.	SIZE		DECK SLAB REPAIR (FD TY I)	DECK SLAB REPAIR (FD TY II)
	LENGTH	WIDTH	SQ YD	SQ YD
1	5.0	2.0		1.1
2	6.0	2.0		1.3
3	3.0	2.0		0.7
4	2.0	5.0		1.1
5	6.0	1.0		0.7
6	4.0	1.0	0.4	
7	4.0	1.0	0.4	
8	1.0	4.0	0.4	
9	4.0	1.0	0.4	
10	10.0	2.0		2.2
11	2.0	2.0	0.4	
12	2.0	2.0	0.4	
13	6.0	2.0		1.3
14	5.0	6.0		3.3
15	3.5	2.0		0.8
16	4.0	2.0		0.9

PATCH NO.	SIZE		DECK SLAB REPAIR (FD TY I)	DECK SLAB REPAIR (FD TY II)
	LENGTH	WIDTH	SQ YD	SQ YD
17	2.0	2.0	0.4	
18	4.0	2.0		0.9
19	6.0	2.0		1.3
20	2.0	3.0		0.7
21	4.0	1.0	0.4	
22	2.0	2.0	0.4	
23	3.0	2.0		0.7
24	2.0	2.0	0.4	
25	4.0	2.0		0.9
26	2.0	2.0	0.4	
27	2.0	2.0	0.4	
28	2.0	4.0		0.9
29	2.0	3.0		0.7
30	4.0	1.0	0.4	
31	3.0	6.0		2.0
32	5.0	4.0		2.2

PATCH NO.	SIZE		DECK SLAB REPAIR (FD TY I)	DECK SLAB REPAIR (FD TY II)
	LENGTH	WIDTH	SQ YD	SQ YD
33	3.0	8.0		2.7
34	1.0	3.0	0.3	
35	5.0	3.0		1.7
36	2.0	5.0		1.1
TOTALS			6.1	29.1
ROUND TO:			7	30

PATCH NO.	SIZE			STRUC. REPAIR OF CONCRETE (DEPTH ≤ 5')
	LENGTH	WIDTH	HEIGHT	
C1	32.0	1.0	0.50	48.0
C2	21.0	1.0	0.50	31.5
C3	18.0	1.0	0.50	27.0
TOTAL				107.0

ESTIMATED PAY QUANTITIES
 DECK SLAB REPAIR (FULL DEPTH, TYPE 1) = 7 SQ YD
 DECK SLAB REPAIR (FULL DEPTH, TYPE 2) = 30 SQ YD
 STRUCTURAL REPAIR OF CONCRETE (DEPTH ≤ 5') = 107 SQ FT

THE LOCATIONS AND SIZES SHOWN GRAPHICALLY ABOVE ARE APPROXIMATE. SEE THIS TABLE FOR ACTUAL SIZES.

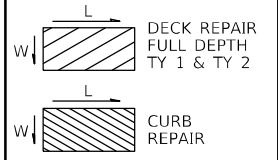

DATE OF SURVEY: 2-21-2020
 SURVEY BY: DPM & RAW
 METHOD OF SURVEY: VISUAL

MODEL: Default
FILE NAME: p:\11\moo\04\illinois\p\p\DOT\Documents\DOT_Offices\B\trc_7\Projects\17499\1\CAD\Drawings\058-0020_Deck_Repair.dwg

USER NAME = stefenmk	DESIGNED - T. Walk	REVISED -
PLOT SCALE = 100,000' / in.	DRAWN - T. Walk	REVISED -
PLOT DATE = 1/22/2021	CHECKED - D. Macklin	REVISED -
	DATE - May 2020	REVISED -

**STATE OF ILLINOIS
DEPARTMENT OF TRANSPORTATION**

**BRIDGE DECK PATCHING & CURB REPAIR, SPAN 1
SN. 058-0020**

SCALE: SHEET 11 OF 13 SHEETS STA. TO STA.

F.A.P. RTE.	SECTION	COUNTY	TOTAL SHEETS	SHEET NO.
320	D7 BRIDGE REPAIRS 2021-7	MACON	33	26
CONTRACT NO. 74994				
ILLINOIS FED. AID PROJECT				

058-0020 Mid Span

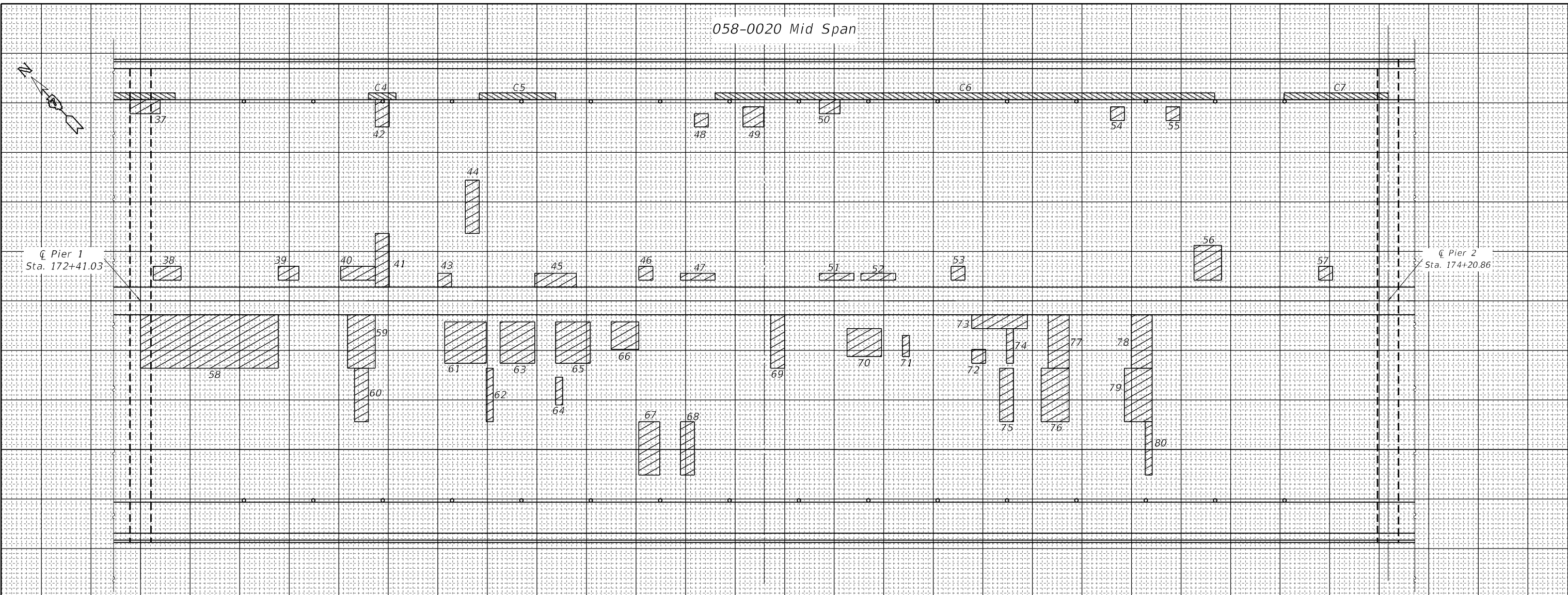

PATCH NO.	SIZE		DECK SLAB REPAIR (FD TY I)	DECK SLAB REPAIR (FD TY II)
	LENGTH	WIDTH	SQ YD	SQ YD
37	4.0	2.0		0.9
38	4.0	2.0		0.9
39	3.0	2.0		0.7
40	5.0	2.0		1.1
41	2.0	8.0		1.8
42	2.0	4.0		0.9
43	2.0	2.0	0.4	
44	2.0	8.0		1.8
45	6.0	2.0		1.3
46	2.0	2.0	0.4	
47	5.0	1.0	0.6	
48	2.0	2.0	0.4	
49	3.0	3.0		1.0
50	3.0	2.0		0.7
51	5.0	1.0	0.6	
52	5.0	1.0	0.6	

PATCH NO.	SIZE		DECK SLAB REPAIR (FD TY I)	DECK SLAB REPAIR (FD TY II)
	LENGTH	WIDTH	SQ YD	SQ YD
53	2.0	2.0	0.4	
54	2.0	2.0	0.4	
55	2.0	2.0	0.4	
56	4.0	5.0		2.2
57	2.0	2.0	0.4	
58	20.0	8.0		17.8
59	4.0	8.0		3.6
60	2.0	8.0		1.8
61	6.0	6.0		4.0
62	1.0	8.0		0.9
63	5.0	6.0		3.3
64	1.0	4.0	0.4	
65	5.0	6.0		3.3
66	4.0	4.0		1.8
67	3.0	8.0		2.7
68	2.0	8.0		1.8

PATCH NO.	SIZE		DECK SLAB REPAIR (FD TY I)	DECK SLAB REPAIR (FD TY II)
	LENGTH	WIDTH	SQ YD	SQ YD
69	2.0	8.0		1.8
70	5.0	4.0		2.2
71	1.0	3.0	0.3	
72	2.0	2.0	0.4	
73	7.0	2.0		1.6
74	1.0	6.0		0.7
75	2.0	8.0		1.8
76	4.0	8.0		3.6
77	3.0	8.0		2.7
78	3.0	8.0		2.7
79	4.0	8.0		3.6
80	1.0	8.0		0.9
TOTALS			6.0	75.4
ROUND TO:			6	76

PATCH	SIZE			STRUC. REPAIR OF CONCRETE (DEPTH ≤ 5')
	LENGTH	WIDTH	HEIGHT	
C4	4.0	1.0	0.50	6.0
C5	11.0	1.0	0.50	16.5
C6	72.0	1.0	0.50	108.0
C7	15.0	1.0	0.50	22.5
TOTAL				153.0

ESTIMATED PAY QUANTITIES
 DECK SLAB REPAIR (FULL DEPTH, TYPE 1) = 6 SQ YD
 DECK SLAB REPAIR (FULL DEPTH, TYPE 2) = 76 SQ YD
 STRUCTURAL REPAIR OF CONCRETE (DEPTH ≤ 5') = 153 SQ FT

THE LOCATIONS AND SIZES SHOWN GRAPHICALLY ABOVE ARE APPROXIMATE. SEE THIS TABLE FOR ACTUAL SIZES.

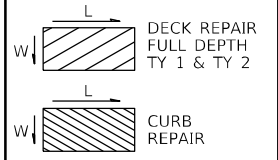

DATE OF SURVEY: 2-21-2020
 SURVEY BY: DPM & RAW
 METHOD OF SURVEY: VISUAL

MODEL: Default
FILE NAME: p:\11\moo\001\illinois\p\058-0020\Documents\DOT_Offices\058-0020\058-0020 Mid Span\058-0020 Deck Repair.dwg

USER NAME = steffemk	DESIGNED - T. Walk	REVISED -
PLOT SCALE = 100,000' / in.	DRAWN - T. Walk	REVISED -
PLOT DATE = 1/22/2021	CHECKED - D. Macklin	REVISED -
	DATE - May 2020	REVISED -

**STATE OF ILLINOIS
DEPARTMENT OF TRANSPORTATION**

**BRIDGE DECK PATCHING & CURB REPAIR, SPAN 2
SN. 058-0020**

SCALE: SHEET 12 OF 13 SHEETS STA. TO STA.

F.A.P. RTE.	SECTION	COUNTY	TOTAL SHEETS	SHEET NO.
320	D7 BRIDGE REPAIRS 2021-7	MACON	33	27
CONTRACT NO. 74994			ILLINOIS FED. AID PROJECT	

058-0020 East Span

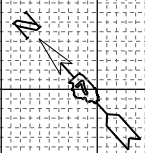

☐ Pier 2
Sta. 174+20.86

Bk. East Abut.
Sta. 175+63.37

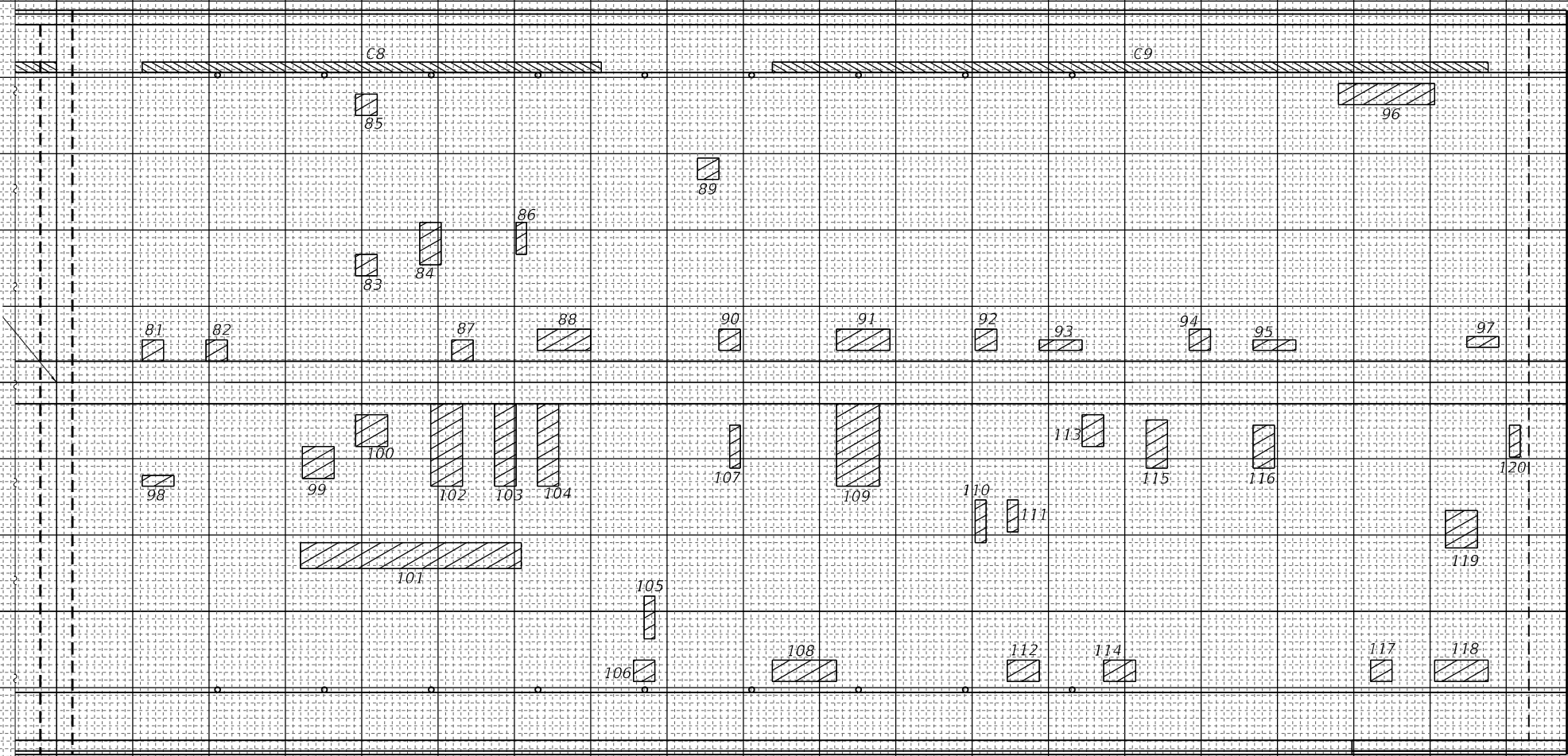

PATCH NO.	SIZE		DECK SLAB REPAIR (FD TY I)	DECK SLAB REPAIR (FD TY II)
	LENGTH	WIDTH	SQ YD	SQ YD
81	2.0	2.0	0.4	
82	2.0	2.0	0.4	
83	2.0	2.0	0.4	
84	2.0	4.0		0.9
85	2.0	2.0	0.4	
86	1.0	3.0	0.3	
87	2.0	2.0	0.4	
88	5.0	2.0		1.1
89	2.0	2.0	0.4	
90	2.0	2.0	0.4	
91	5.0	2.0		1.1
92	2.0	2.0	0.4	
93	4.0	1.0	0.4	
94	2.0	2.0	0.4	
95	4.0	1.0	0.4	
96	9.0	2.0		2.0

PATCH NO.	SIZE		DECK SLAB REPAIR (FD TY I)	DECK SLAB REPAIR (FD TY II)
	LENGTH	WIDTH	SQ YD	SQ YD
97	3.0	1.0	0.3	
98	3.0	1.0	0.3	
99	3.0	3.0		1.0
100	3.0	3.0		1.0
101	21.0	2.5		5.8
102	3.0	8.0		2.7
103	2.0	8.0		1.8
104	2.0	8.0		1.8
105	1.0	5.0	0.6	
106	2.0	2.0	0.4	
107	1.0	4.0	0.4	
108	5.0	2.0		1.1
109	4.0	8.0		3.6
110	1.0	4.0	0.4	
111	1.0	3.0	0.3	
112	3.0	2.0		0.7

PATCH NO.	SIZE		DECK SLAB REPAIR (FD TY I)	DECK SLAB REPAIR (FD TY II)
	LENGTH	WIDTH	SQ YD	SQ YD
113	2.0	3.0		0.7
114	3.0	2.0		0.7
115	2.0	5.0		1.1
116	2.5	4.0		1.1
117	2.0	2.0	0.4	
118	5.0	2.0		1.1
119	3.0	4.0		1.3
120	1.0	4.0	0.4	
TOTALS			9.0	30.6
ROUND TO:			9	31

PATCH NO.	SIZE			STRUC. REPAIR OF CONCRETE (DEPTH ≤ 5')
	LENGTH	WIDTH	HEIGHT	
C8	43.0	1.0	0.50	64.5
C9	67.0	1.0	0.50	100.5
TOTAL				165.0

ESTIMATED PAY QUANTITIES
 DECK SLAB REPAIR (FULL DEPTH, TYPE 1) = 9 SQ YD
 DECK SLAB REPAIR (FULL DEPTH, TYPE 2) = 31 SQ YD
 STRUCTURAL REPAIR OF CONCRETE (DEPTH ≤ 5') = 165 SQ FT

THE LOCATIONS AND SIZES SHOWN GRAPHICALLY ABOVE ARE APPROXIMATE. SEE THIS TABLE FOR ACTUAL SIZES.

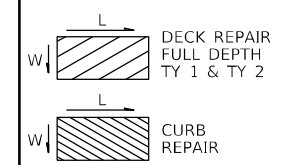

DATE OF SURVEY: 2-21-2020
 SURVEY BY: DPM & RAW
 METHOD OF SURVEY: VISUAL

MODEL: Default
FILE NAME: p:\11\moo\04\illinois\p\01\Documents\DOT_Offices\District_7\Projects\7499\CAD\Drawings\CAD\Drawings\058-0020_Deck_Repair.dwg

USER NAME = stefenmk	DESIGNED - T. Walk	REVISED -
PLOT SCALE = 100,000' / in.	DRAWN - T. Walk	REVISED -
PLOT DATE = 1/22/2021	CHECKED - D. Macklin	REVISED -
	DATE - May 2020	REVISED -

**STATE OF ILLINOIS
DEPARTMENT OF TRANSPORTATION**

**BRIDGE DECK PATCHING & CURB REPAIR, SPAN 3
SN. 058-0020**

SCALE: SHEET 13 OF 13 SHEETS STA. TO STA.

F.A.P. RTE.	SECTION	COUNTY	TOTAL SHEETS	SHEET NO.
320	D7 BRIDGE REPAIRS 2021-7	MACON	33	28
ILLINOIS FED. AID PROJECT			CONTRACT NO. 74994	

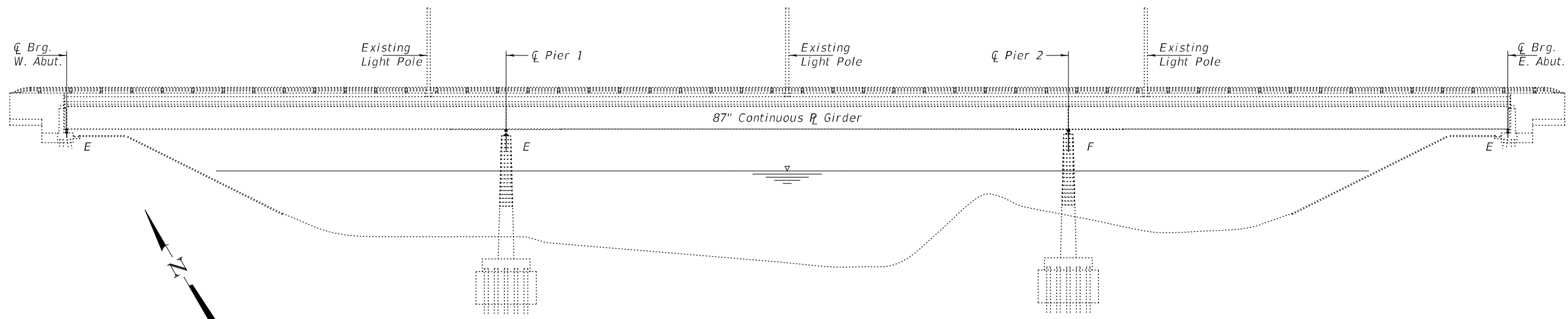

ELEVATION

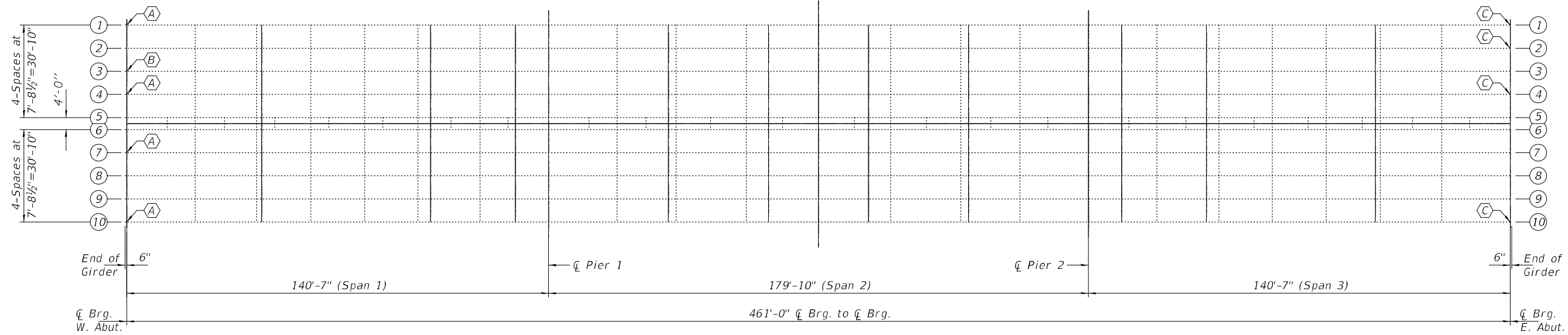

FRAMING PLAN

- (A) - Girder end repair - Repair A
- (B) - Girder end repair - Repair B
- (C) - Girder end repair - Repair C

NOTES

All structural steel shall conform to AASHTO Classification M-270 Gr. 36, unless otherwise noted.

Plan dimensions and details relative to existing plans are subject to nominal construction variations. The Contractor shall field verify existing dimensions and details affecting new construction and make necessary approved adjustments prior to construction or ordering of materials. Such variations shall not be cause for additional compensation for a change in scope of the work, however, the Contractor will be paid for the quantity actually furnished at the unit price bid for the work.

Fasteners shall be high strength bolts. Bolts 3/4"Ø, open holes 13/16"Ø, unless otherwise noted.

Cost of removal and re-installation of all members necessary to complete the work as detailed on the plans and as specified in the Special Provisions shall be included with Structural Steel Repair.

All structural steel shall be shop painted with the inorganic zinc rich primer per AASHTO M300, Type 1. Cost included with Structural Steel Repair.

The existing structural steel coating contains lead. The Contractor shall take appropriate precautions to deal with the presence of lead on this project.

Existing structural steel that will be in contact with new structural steel shall be cleaned and painted prior to erection as required by the GBSP "Cleaning and Painting Contact Surface Areas of Existing Steel Structures".

BILL OF MATERIAL

ITEM	UNIT	QUANTITY
Structural Steel Repairs	Pound	1380
Jack and Remove Existing Bearings	Each	20
Elastomeric Bearing Assembly, Type I	Each	10
Elastomeric Bearing Assembly, Type II	Each	10
Anchor Bolts 1"Ø	Each	40
Furnishing and Erecting Structural Steel	Pound	5220

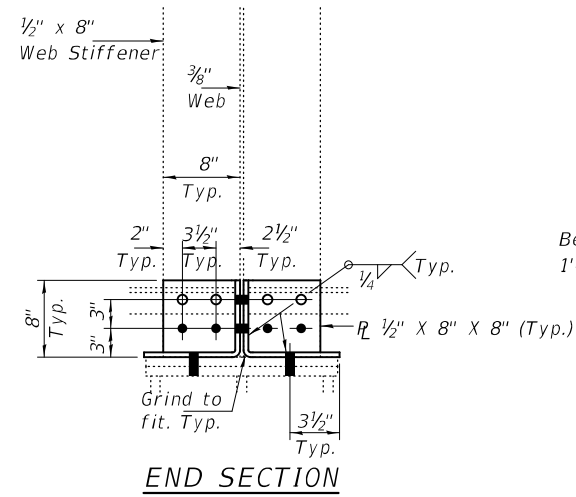

END SECTION

REPAIR A
(4 Locations)

ELEVATION

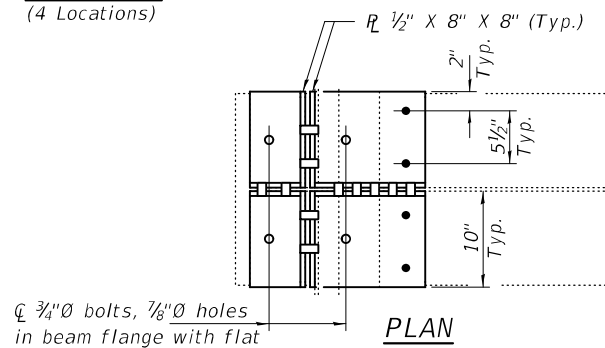

PLAN

Ø 3/4" bolts, 7/8" holes
in beam flange with flat
washers & hex nuts.
(4 Reqd.)

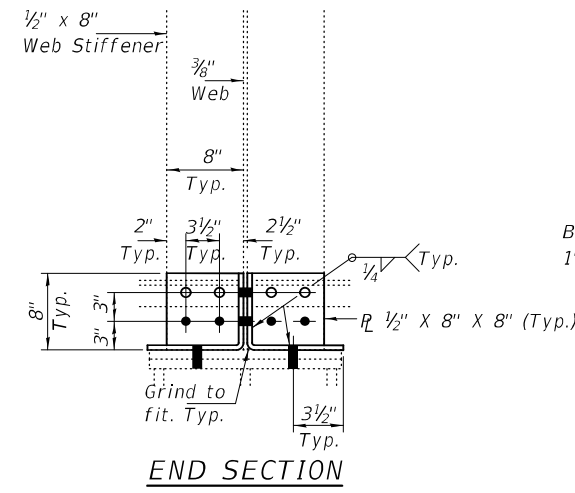

END SECTION

REPAIR B
(1 Location)

ELEVATION

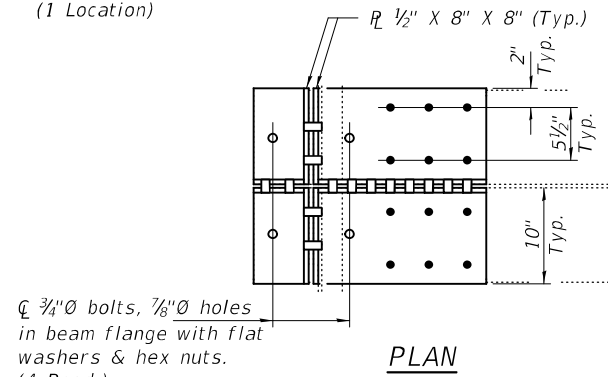

PLAN

Ø 3/4" bolts, 7/8" holes
in beam flange with flat
washers & hex nuts.
(4 Reqd.)

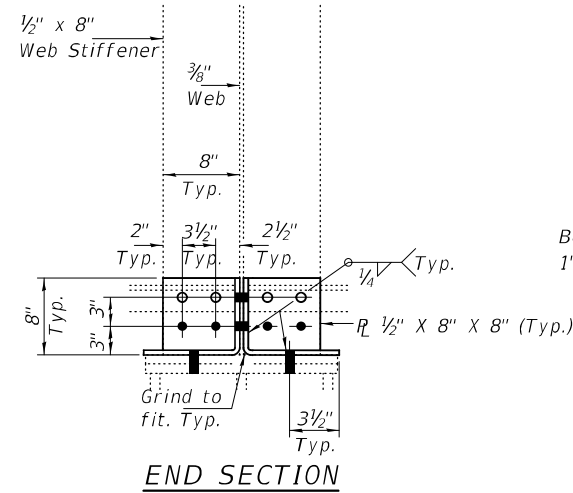

END SECTION

REPAIR C
(4 Locations)

ELEVATION

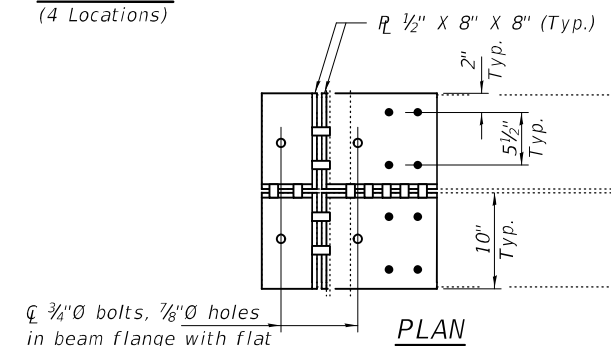

PLAN

Ø 3/4" bolts, 7/8" holes
in beam flange with flat
washers & hex nuts.
(4 Reqd.)

BOLT HOLE LEGEND

- - Field drill using existing steel as template.
- - Field drill using new steel as template.

DESIGNED - VHV
CHECKED - AJR
DRAWN - daburdell
CHECKED - VHV AJR

EXAMINED
PASSED
Timothy A. [Signature]
ENGINEER OF STRUCTURAL SERVICES
[Signature]
ENGINEER OF BRIDGES AND STRUCTURES

DATE - MARCH 08, 2021
REVISED -
REVISED -

STATE OF ILLINOIS
DEPARTMENT OF TRANSPORTATION

REPAIR DETAILS
SN 058-0020

SHEET NO. 2 OF 4 SHEETS

F.A.P. RTE.	SECTION	COUNTY	TOTAL SHEETS	SHEET NO.
320	D7 Bridge Repairs 2021-7	MACON	33	30
			CONTRACT NO. 74994	
ILLINOIS FED. AID PROJECT				

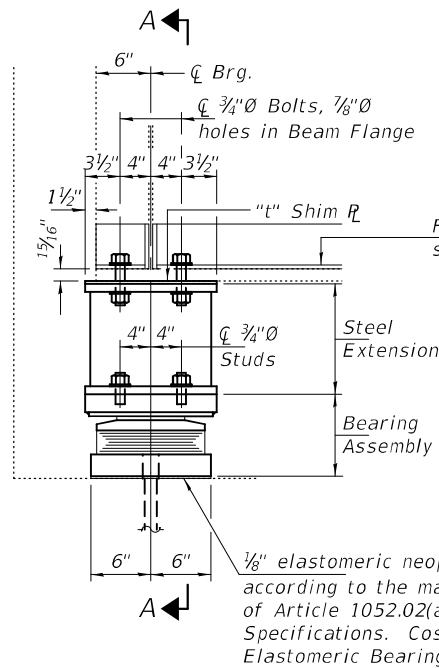

ELEVATION AT ABUTMENT

TYPE II TFE ELASTOMERIC EXP. BRG.

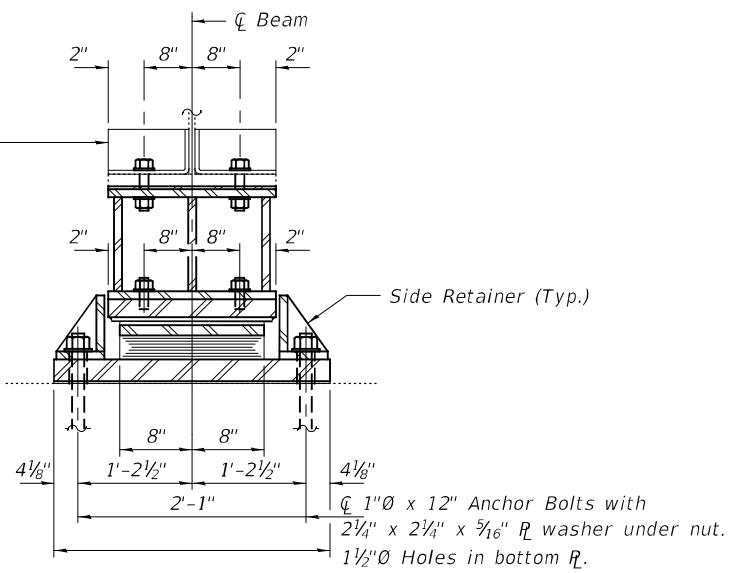

SECTION A-A

BEAM REACTIONS

R _U	(K)	69.7
R _L	(K)	46.5
Imp.	(K)	8.7
R (Total)	(K)	124.9

Notes:
 Diaphragm removal and reinstallation may be required to facilitate drilling holes. Cost included with Furnishing and Erecting Structural Steel.
 New steel extensions, shim plates and connection bolts are included with Furnishing and Erecting Structural Steel.
 Prior to ordering any material, the Contractor shall verify in the field all bearing height and shim thickness dimensions. Adjustment must account for deck heave due to pack rust (if present).
 Min. jack capacity = 55 Tons.

Anchor bolts shall be ASTM F1554 all-thread (or an Engineer-approved alternate material) of the grade(s) and diameter(s) specified. ASTM A307 Grade C anchor bolts may be used in lieu of ASTM F1554 Grade 36 (F_y=36ksi). The corresponding specified grade of AASHTO M314 anchor bolts may be used in lieu of ASTM F1554.

Anchor bolts at fixed bearings may be either cast in place or installed in holes drilled after the supported member is in place.

Anchor bolts for Type II bearings shall be placed in holes drilled through the bottom bearing plate after members are in place. Side retainers shall be placed after bolts are installed.

Drilled and set anchor bolts shall be installed according to Article 521.06 of the Standard Specifications.

Side retainers shall be included in the cost of Elastomeric Bearing Assembly, Type II.

The 1/8" PTFE sheet shall be bonded directly to the top steel plate with a two-component, medium viscosity epoxy resin, conforming to the requirements of the Federal Specification MMM-A-134, Type I. The bond agent shall be applied on the full area of the contact surfaces.

Bonding of 1/8" PTFE sheet during vulcanizing process will be permitted provided the process and method of adjusting assembly height is approved by the Engineer.

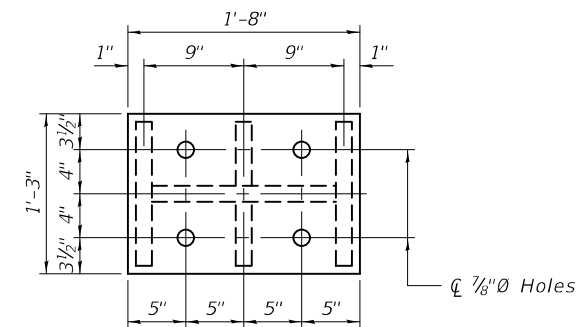

PLAN TOP AND BOTTOM PLATE

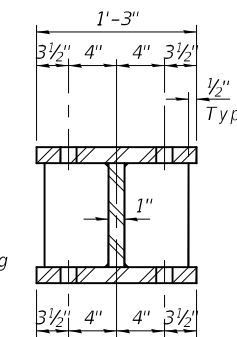

SECTION B-B

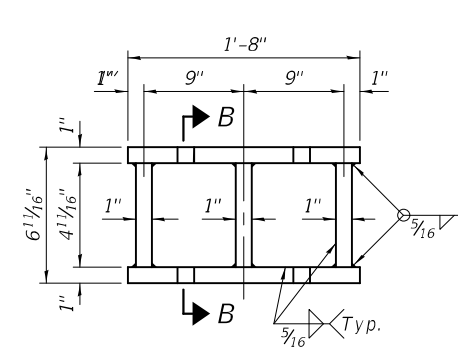

STEEL EXTENSION DETAIL

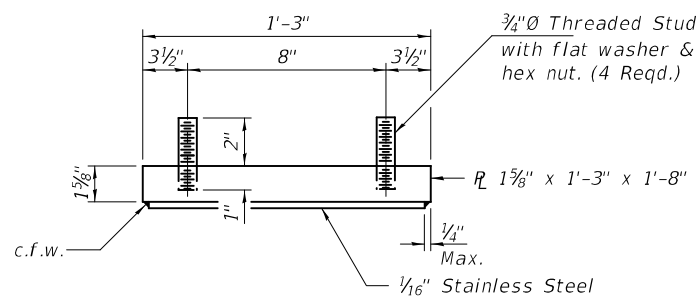

TOP BEARING ASSEMBLY

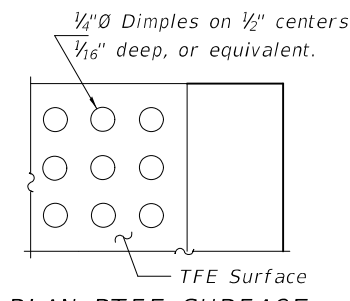

PLAN-PTFE SURFACE

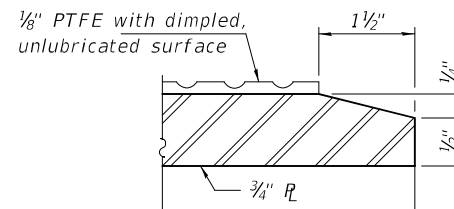

SECTION THRU PTFE

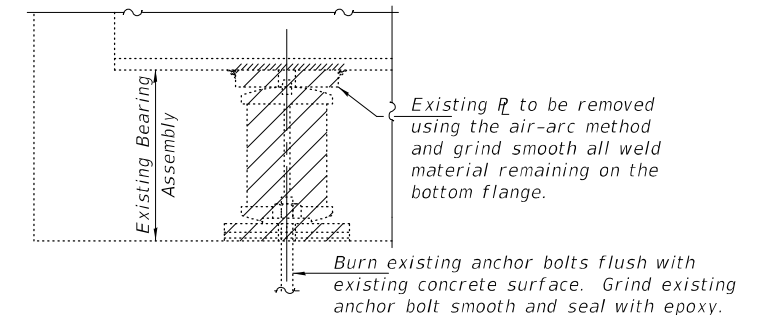

EXISTING BEARING REMOVAL DETAIL

Cost included with Jack and Remove Existing Bearings.

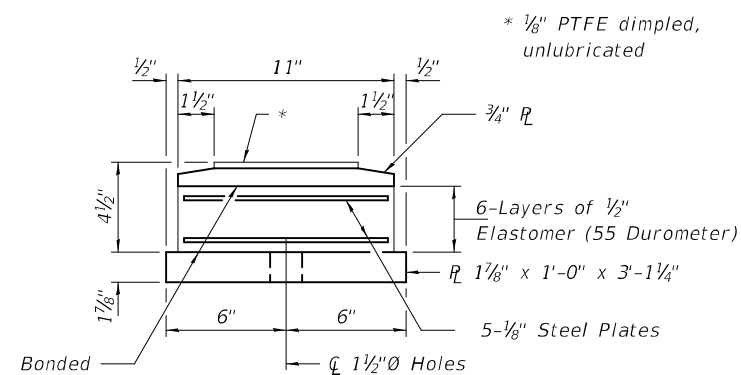

BOTTOM BEARING ASSEMBLY

* 1/8" PTFE dimpled, unlubricated

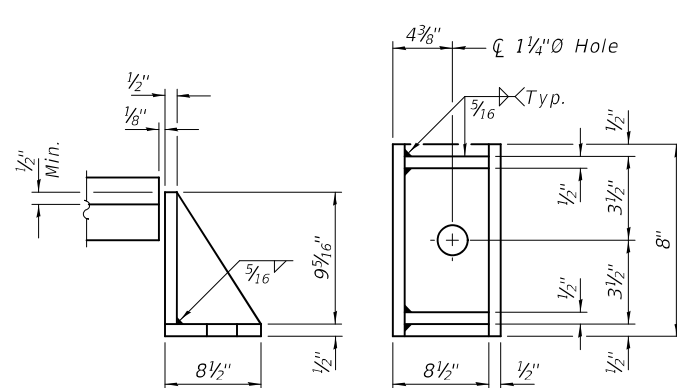

SIDE RETAINER

Equivalent rolled angle with stiffeners will be allowed in lieu of welded plates.

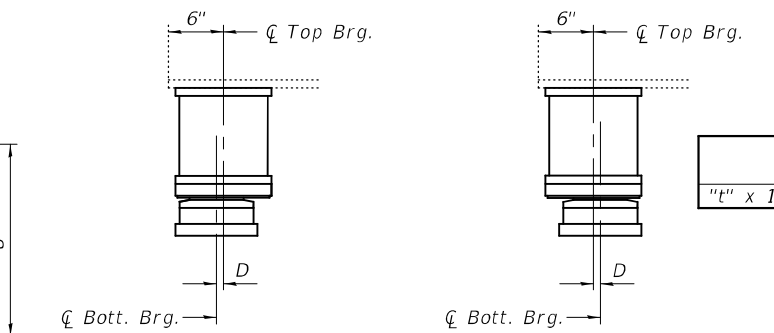

BELOW 50° F. (Move bott. brg. away from fixed brg.) ABOVE 50° F. (Move bott. brg. toward fixed brg.)

SETTING ANCHOR BOLTS AT EXP. BRG.

D = 1/8" per each 100' of expansion for every 15° temp. change from the normal temp. of 50°F.

SHIM PLATE SIZES

Size	"t" Dimensions at Bems									
	1	2	3	4	5	6	7	8	9	10
1" x 1'-3" x 1'-8"	0	3/4	1/2	1/4	0	0	1/4	1/2	3/4	0

BILL OF MATERIAL

Item	Unit	Total
Elastomeric Bearing Assembly, Type II	Each	10
Jack and Remove Existing Bearings	Each	10
Furnishing and Erecting Structural Steel	Pound	2625
Anchor Bolts 1"Ø	Each	20

TYII/REPS 08-08-2018

DESIGNED - VHV	EXAMINED
CHECKED - AJR	PASSED
DRAWN - daburdell	
CHECKED - VHV AJR	

 ENGINEER OF STRUCTURAL SERVICES	DATE - MARCH 08, 2021
 ENGINEER OF BRIDGES AND STRUCTURES	REVISED - REVISED -

STATE OF ILLINOIS
 DEPARTMENT OF TRANSPORTATION

BEARING DETAILS - WEST ABUTMENT
 SN 058-0020

SHEET NO. 3 OF 4 SHEETS

F.A.P. RTE.	SECTION	COUNTY	TOTAL SHEETS	SHEET NO.
320	D7 Bridge Repairs 2021-7	MACON	33	31
CONTRACT NO. 74994				
ILLINOIS FED. AID PROJECT				

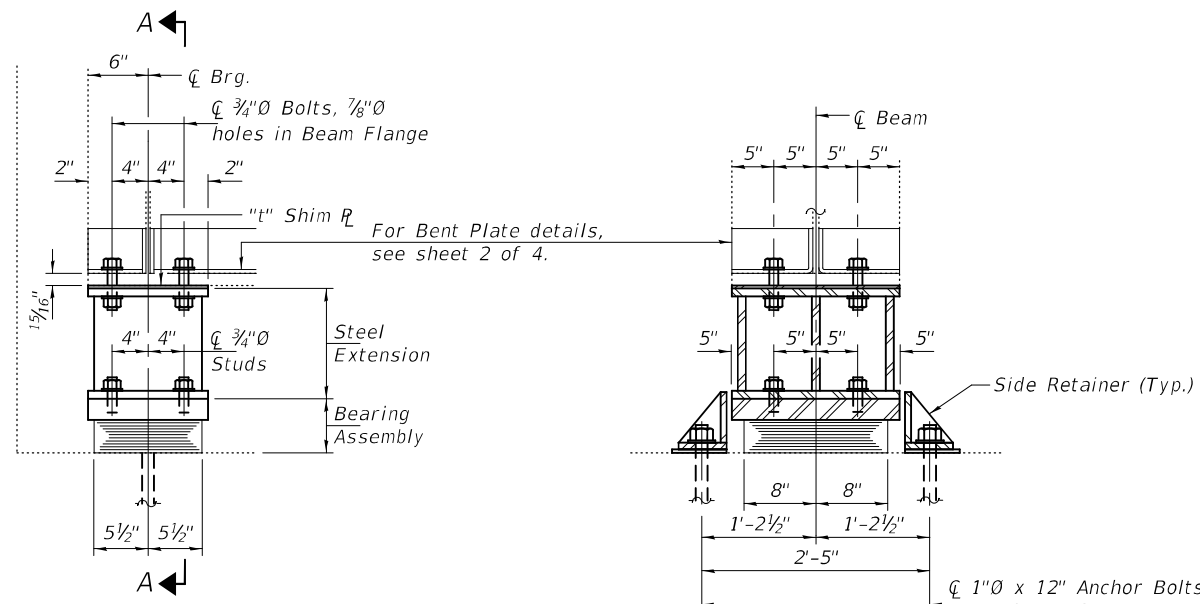

ELEVATION AT ABUTMENT

SECTION A-A

TYPE I ELASTOMERIC EXP. BRG.

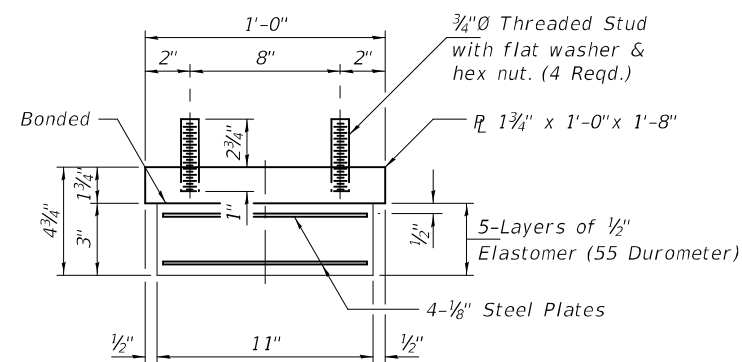

BEARING ASSEMBLY

Note:
Shim plates shall not be placed under Bearing Assembly.

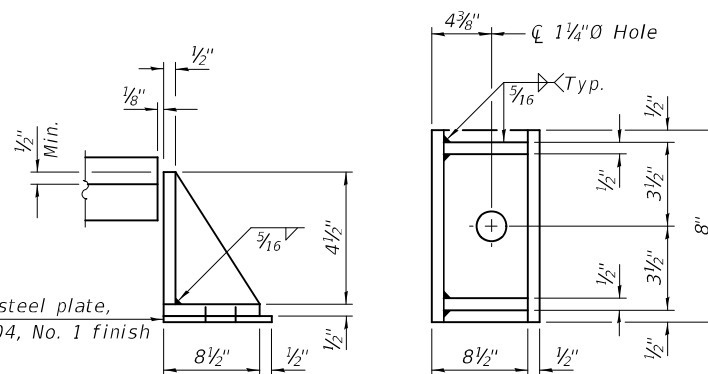

SIDE RETAINER

Equivalent rolled angle with stiffeners will be allowed in lieu of welded plates.

BEAM REACTIONS

R _D	(K)	69.7
R _L	(K)	46.5
Imp.	(K)	8.7
R (Total)	(K)	124.9

Notes:
Diaphragm removal and reinstallation may be required to facilitate drilling holes. Cost included with Furnishing and Erecting Structural Steel.
New steel extensions, shim plates and connection bolts are included with Furnishing and Erecting Structural Steel.
Prior to ordering any material, the Contractor shall verify in the field all bearing height and shim thickness dimensions. Adjustment must account for deck heave due to pack rust (if present).
Min. jack capacity = 55 Tons.
Anchor bolts shall be ASTM F1554 all-thread (or an Engineer-approved alternate material) of the grade(s) and diameter(s) specified. ASTM A307 Grade C anchor bolts may be used in lieu of ASTM F1554 Grade 36 (Fy=36ksi). The corresponding specified grade of AASHTO M314 anchor bolts may be used in lieu of ASTM F1554.
Drilled and set anchor bolts shall be installed according to Article 521.06 of the Standard Specifications.
Cost of Side retainers and Stainless Steel plates shall be included in the cost of Elastomeric Bearing Assembly, Type I.

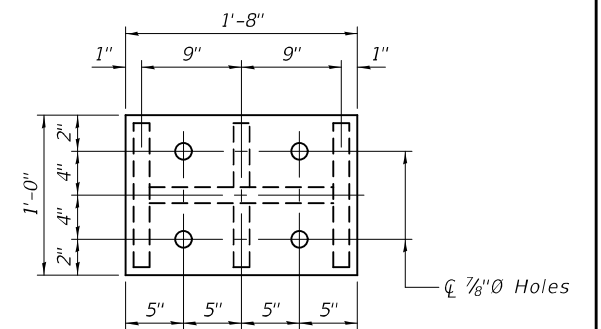

PLAN TOP AND BOTTOM PLATE

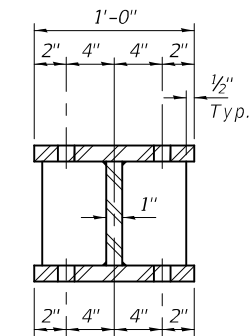

SECTION B-B

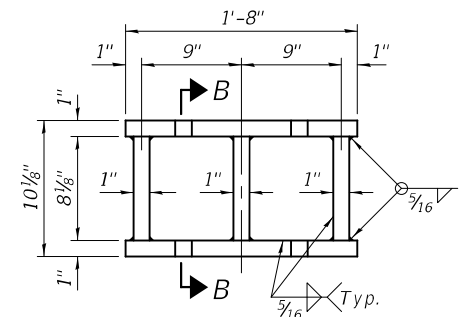

STEEL EXTENSION DETAIL

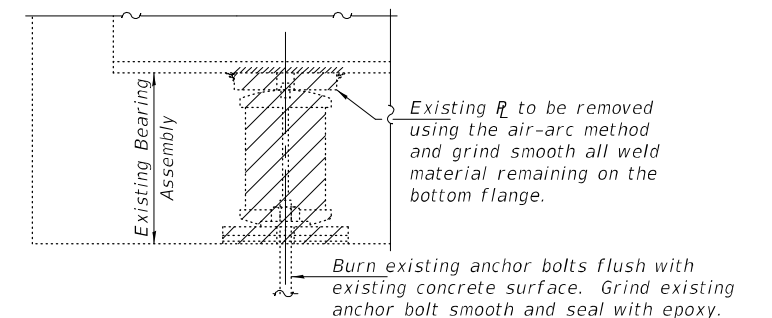

EXISTING BEARING REMOVAL DETAIL

Cost included with Jack and Remove Existing Bearings.

SHIM PLATE SIZES

Size	"t" Dimensions at Bems									
	1	2	3	4	5	6	7	8	9	10
"t" x 1'-0" x 1'-8"	0	3/4	1/2	1/4	0	0	1/4	1/2	3/4	0

BILL OF MATERIAL

Item	Unit	Total
Elastomeric Bearing Assembly, Type I	Each	10
Jack and Remove Existing Bearings	Each	10
Furnishing and Erecting Structural Steel	Pound	2595
Anchor Bolts, 1"Ø	Each	20

TYI/REPS 5-17-2018

DETAIL OF CONCRETE MEDIAN, TYPE SM-6 (SM-15) (DOWELED)

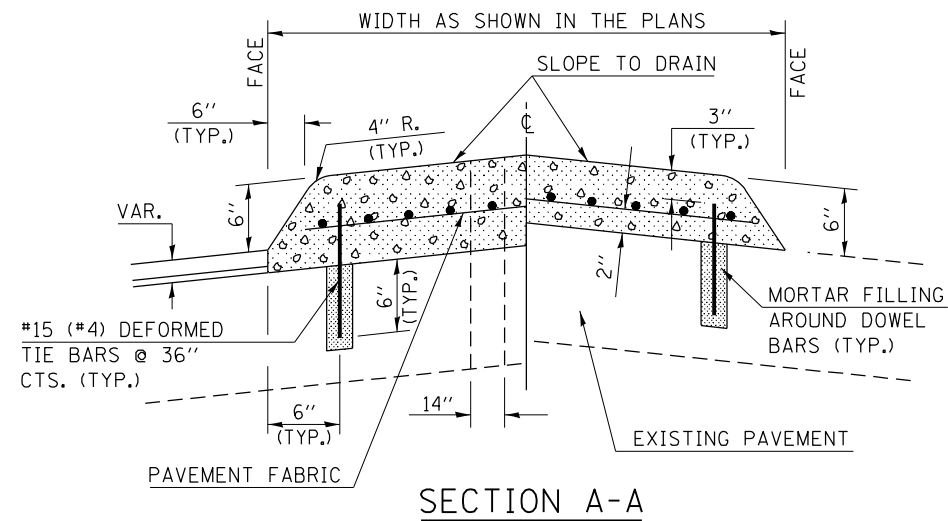

GENERAL NOTES

1. THE GENERAL NOTES FOR STANDARD 606301 SHALL APPLY.
2. SECTION G-G SHALL BE THE SAME AS SHOWN ON STANDARD 606301.
3. DOWEL BARS @ 36" CTS. OR AS DIRECTED BY THE ENGINEER.
4. THIS WORK WILL BE PAID FOR AT THE CONTRACT UNIT PRICE PER SQ FOOT FOR CONCRETE MEDIAN, TYPE SM-6 (SM-15) (DOWELED), INCLUDING THE COST OF FURNISHING AND INSTALLING THE DOWEL BARS, MORTAR FILLING, PAVEMENT FABRIC AND THE REMOVAL AND DISPOSAL OF THE EXISTING PAVEMENT FOR THE 14" x 14" OPENING, IF REQUIRED, AND NO ADDITIONAL COMPENSATION WILL BE ALLOWED.

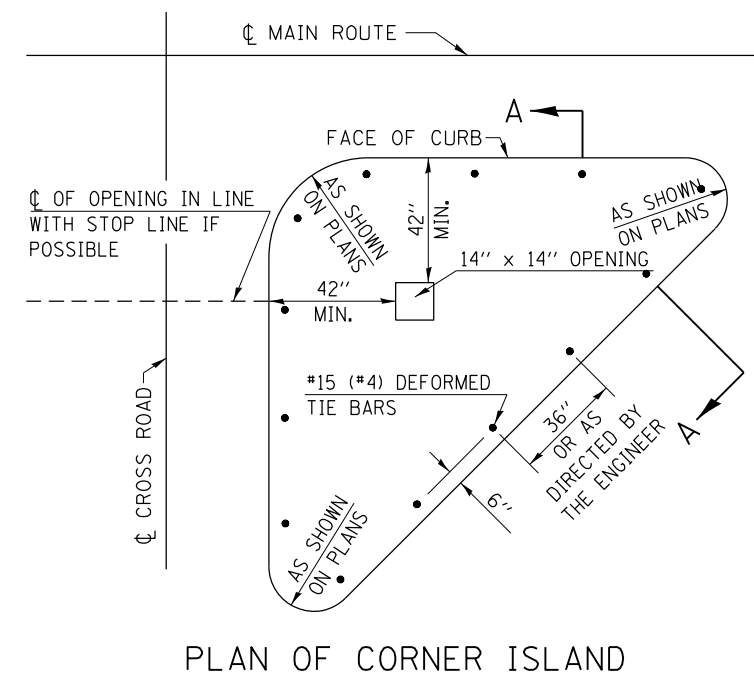
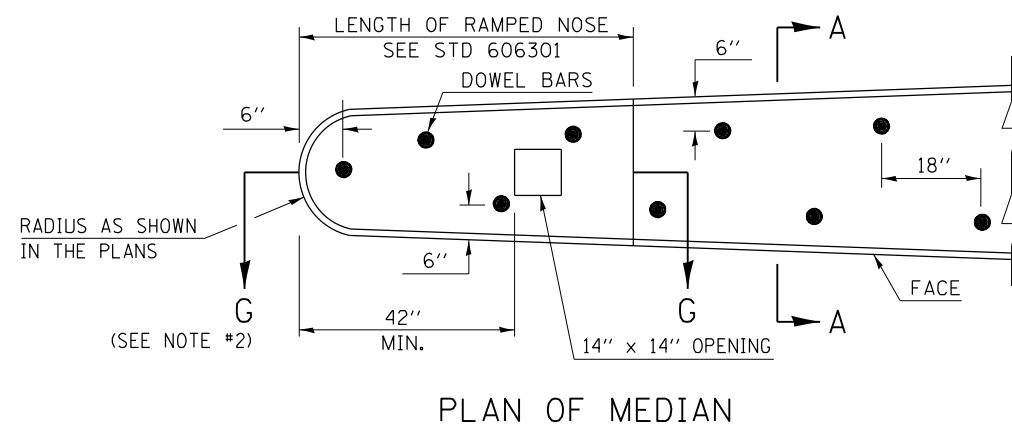

MODEL: Default
 FILE NAME: p:\pub\harronm.dwt
 PROJECT: 74994\CADD\Drawings\DOT - Office\Drawings\74994\Drawings\74994-1-1.dwg

USER NAME = steffnmk	DESIGNED -	REVISED -
PLOT SCALE = 100,0000' / in.	DRAWN -	REVISED -
PLOT DATE = 1/22/2021	CHECKED -	REVISED -
	DATE -	REVISED -

**STATE OF ILLINOIS
DEPARTMENT OF TRANSPORTATION**

**CONCRETE MEDIAN, TYPE SM (DOWELED)
DETAIL**

SCALE: SHEET 1 OF 1 SHEETS STA. TO STA.

F.A.P. RTE.	SECTION	COUNTY	TOTAL SHEETS	SHEET NO.
320	D7 BRIDGE REPAIRS 2021-7	MACON	33	33
CONTRACT NO. 74994				
ILLINOIS FED. AID PROJECT				