

F.A. RTE.	SECTION	COUNTY	TOTAL SHEETS	SHEET NO.
351	3277R	COOK	541	301
STA. TO STA.		ILLINOIS FED. AID PROJECT		
FED. ROAD DIST. NO.		CONTRACT NO. 60774		

THE FOLLOWING ITEMS SHALL BE REMOVED BY THE CONTRACTOR AND SHALL BE DISPOSED OF BY THEM OUTSIDE THE RIGHT-OF-WAY AT THEIR EXPENSE. THE SALVAGE VALUE OF THE REMOVED EQUIPMENT SHALL BE REFLECTED IN THE CONTRACT BID PRICE.

- 1 EACH CONTROLLER AND CABINET (COMPLETE)
- 1 EACH MASTER CONTROLLER
- 4 EACH ALUMINUM MAST ARM ASSEMBLY AND POLE
- 8 EACH SIGNAL HEAD, 1 - FACE
- 4 EACH SIGNAL HEAD, 2 - FACE
- 1 EACH SERVICE INSTALLATION
- 4 EACH TRAFFIC SIGNAL POST

EXISTING EQUIPMENT TO BE REMOVED LEGEND

- EXISTING SIGNAL HEAD TO BE REMOVED
- EXISTING SERVICE INSTALLATION TO BE REMOVED
- EXISTING CONTROLLER TO BE REMOVED
- EXISTING HANDHOLE TO BE REMOVED
- EXISTING PEDESTRIAN SIGNAL HEAD TO BE REMOVED
- EXISTING PEDESTRIAN PUSH BUTTON TO BE REMOVED
- EMERGENCY VEHICLE LIGHT DETECTOR TO BE REMOVED
- CONFIRMATION BEACON TO BE REMOVED
- EXISTING HEAVY-DUTY HANDHOLE TO BE REMOVED
- EXISTING SIGNAL POST AND FOUNDATION TO BE REMOVED
- EXISTING ALUMINUM MAST ARM POLE AND FOUNDATION TO BE REMOVED
- EXISTING STEEL MAST ARM POLE AND FOUNDATION TO BE REMOVED
- EXISTING STEEL COMBINATION MAST ARM POLE AND FOUNDATION TO BE REMOVED

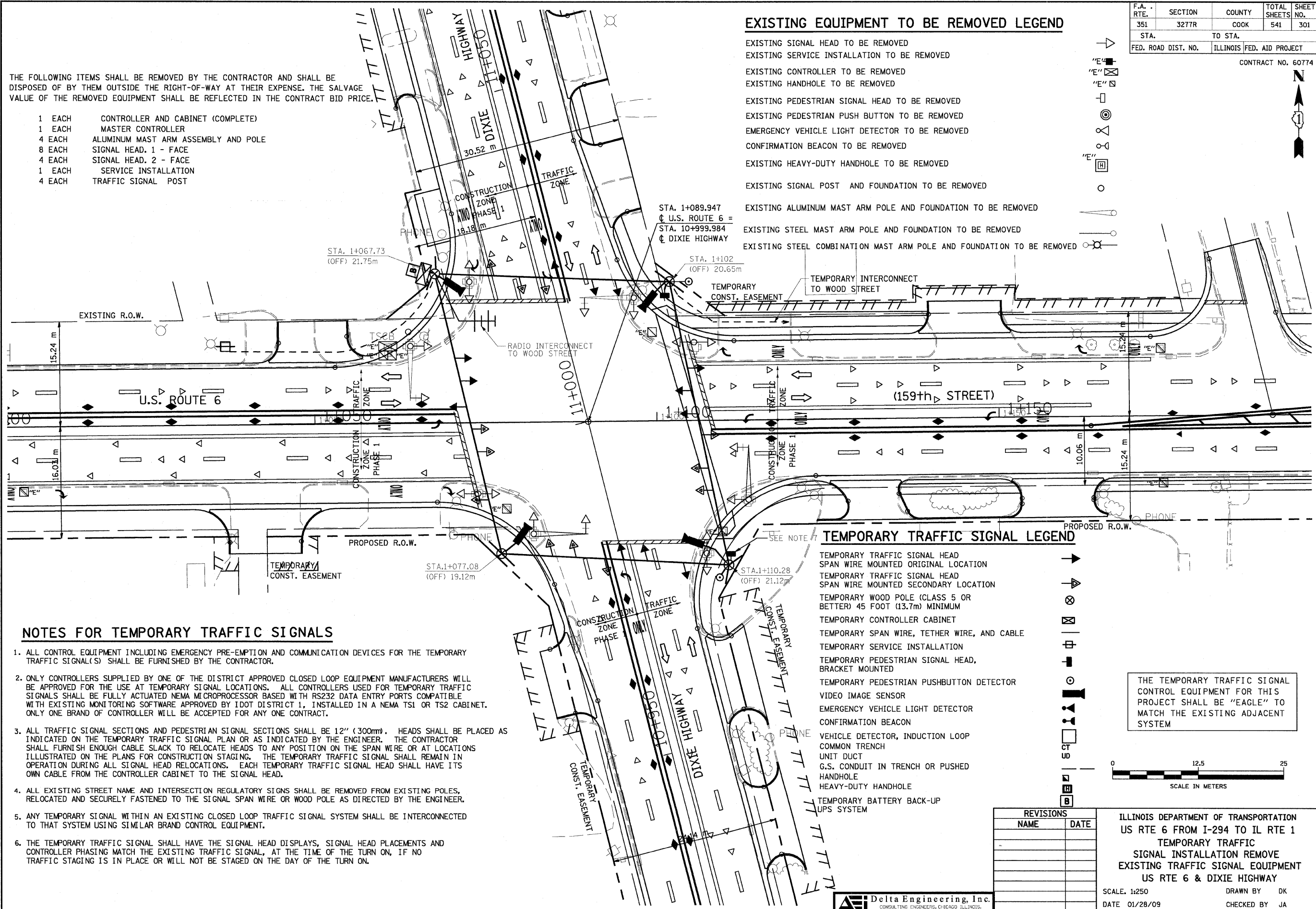
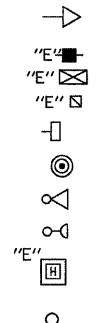

NOTES FOR TEMPORARY TRAFFIC SIGNALS

- ALL CONTROL EQUIPMENT INCLUDING EMERGENCY PRE-EMPTION AND COMMUNICATION DEVICES FOR THE TEMPORARY TRAFFIC SIGNAL(S) SHALL BE FURNISHED BY THE CONTRACTOR.
- ONLY CONTROLLERS SUPPLIED BY ONE OF THE DISTRICT APPROVED CLOSED LOOP EQUIPMENT MANUFACTURERS WILL BE APPROVED FOR THE USE AT TEMPORARY SIGNAL LOCATIONS. ALL CONTROLLERS USED FOR TEMPORARY TRAFFIC SIGNALS SHALL BE FULLY ACTUATED NEMA MICROPROCESSOR BASED WITH RS232 DATA ENTRY PORTS COMPATIBLE WITH EXISTING MONITORING SOFTWARE APPROVED BY IDOT DISTRICT 1, INSTALLED IN A NEMA TS1 OR TS2 CABINET. ONLY ONE BRAND OF CONTROLLER WILL BE ACCEPTED FOR ANY ONE CONTRACT.
- ALL TRAFFIC SIGNAL SECTIONS AND PEDESTRIAN SIGNAL SECTIONS SHALL BE 12" (300mm). HEADS SHALL BE PLACED AS INDICATED ON THE TEMPORARY TRAFFIC SIGNAL PLAN OR AS INDICATED BY THE ENGINEER. THE CONTRACTOR SHALL FURNISH ENOUGH CABLE SLACK TO RELOCATE HEADS TO ANY POSITION ON THE SPAN WIRE OR AT LOCATIONS ILLUSTRATED ON THE PLANS FOR CONSTRUCTION STAGING. THE TEMPORARY TRAFFIC SIGNAL SHALL REMAIN IN OPERATION DURING ALL SIGNAL HEAD RELOCATIONS. EACH TEMPORARY TRAFFIC SIGNAL HEAD SHALL HAVE ITS OWN CABLE FROM THE CONTROLLER CABINET TO THE SIGNAL HEAD.
- ALL EXISTING STREET NAME AND INTERSECTION REGULATORY SIGNS SHALL BE REMOVED FROM EXISTING POLES, RELOCATED AND SECURELY FASTENED TO THE SIGNAL SPAN WIRE OR WOOD POLE AS DIRECTED BY THE ENGINEER.
- ANY TEMPORARY SIGNAL WITHIN AN EXISTING CLOSED LOOP TRAFFIC SIGNAL SYSTEM SHALL BE INTERCONNECTED TO THAT SYSTEM USING SIMILAR BRAND CONTROL EQUIPMENT.
- THE TEMPORARY TRAFFIC SIGNAL SHALL HAVE THE SIGNAL HEAD DISPLAYS, SIGNAL HEAD PLACEMENTS AND CONTROLLER PHASING MATCH THE EXISTING TRAFFIC SIGNAL, AT THE TIME OF THE TURN ON, IF NO TRAFFIC STAGING IS IN PLACE OR WILL NOT BE STAGED ON THE DAY OF THE TURN ON.

TEMPORARY TRAFFIC SIGNAL LEGEND

- TEMPORARY TRAFFIC SIGNAL HEAD SPAN WIRE MOUNTED ORIGINAL LOCATION
- TEMPORARY TRAFFIC SIGNAL HEAD SPAN WIRE MOUNTED SECONDARY LOCATION
- TEMPORARY WOOD POLE (CLASS 5 OR BETTER) 45 FOOT (13.7m) MINIMUM
- TEMPORARY CONTROLLER CABINET
- TEMPORARY SPAN WIRE, TETHER WIRE, AND CABLE
- TEMPORARY SERVICE INSTALLATION
- TEMPORARY PEDESTRIAN SIGNAL HEAD, BRACKET MOUNTED
- TEMPORARY PEDESTRIAN PUSHBUTTON DETECTOR
- VIDEO IMAGE SENSOR
- EMERGENCY VEHICLE LIGHT DETECTOR
- CONFIRMATION BEACON
- VEHICLE DETECTOR, INDUCTION LOOP
- COMMON TRENCH
- UNIT DUCT
- G.S. CONDUIT IN TRENCH OR PUSHED
- HANDHOLE
- HEAVY-DUTY HANDHOLE
- TEMPORARY BATTERY BACK-UP UPS SYSTEM

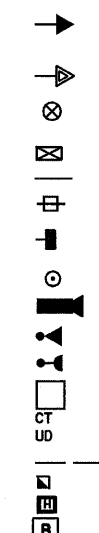

THE TEMPORARY TRAFFIC SIGNAL CONTROL EQUIPMENT FOR THIS PROJECT SHALL BE "EAGLE" TO MATCH THE EXISTING ADJACENT SYSTEM

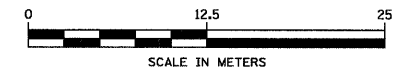

REVISIONS	
NAME	DATE

ILLINOIS DEPARTMENT OF TRANSPORTATION
 US RTE 6 FROM I-294 TO IL RTE 1
 TEMPORARY TRAFFIC
 SIGNAL INSTALLATION REMOVE
 EXISTING TRAFFIC SIGNAL EQUIPMENT
 US RTE 6 & DIXIE HIGHWAY

SCALE: 1:250
 DATE 01/28/09

DRAWN BY DK
 CHECKED BY JA

TEMPORARY CABLE DIAGRAM LEGEND

- TEMPORARY TRAFFIC SIGNAL SECTION OR PEDESTRIAN SIGNAL SECTION 12" (300 mm)
- TEMPORARY CONTROLLER CABINET
- TEMPORARY SERVICE INSTALLATION
- INDICATES NUMBER OF CONDUCTORS IN CABLE. ALL CONDUCTORS TO BE NUMBER 14 AWG WIRE UNLESS OTHERWISE NOTED.
- EMERGENCY VEHICLE LIGHT DETECTOR
- CONFIRMATION BEACON
- PEDESTRIAN PUSHBUTTON DETECTOR
- VEHICLE DETECTOR, INDUCTION LOOP
- 12" (300mm) PEDESTRIAN SIGNAL SECTION
- VIDEO IMAGE SENSOR
- TEMPORARY BATTERY BACK-UP UPS SYSTEM

CONSTRUCTION NOTES

1. THE EXISTING TRAFFIC RESPONSIVE CLOSED LOOP SYSTEM OPERATION SHALL BE MAINTAINED DURING CONSTRUCTION. THE CONTRACTOR SHALL CONTACT THE S.C.A.T. SYSTEMS ENGINEER, MR. GEORGE BROWN AT (847) 697-6700 AT LEAST 72 HOURS PRIOR TO THE START OF WORK TO REQUEST MODIFICATION OF THE EXISTING TRAFFIC RESPONSIVE PROGRAM. UPON COMPLETION AND ACCEPTANCE OF THE TRAFFIC SIGNAL MODIFICATIONS, THE CONTRACTOR SHALL CONTACT THE SIGNAL SYSTEM ENGINEER TO REQUEST RESTORATION OF THE ORIGINAL TRAFFIC RESPONSIVE PROGRAM.
2. THE CONTRACTOR SHALL MAINTAIN THE EXISTING SIGNAL SYSTEM INTERCONNECT DURING TEMPORARY SIGNAL OPERATION. THE INSTALLATION OF THE TEMPORARY INTERCONNECT CABLE OR RADIO SHALL BE NON-DESTRUCTIVE. THE INSTALLATION AND MAINTENANCE OF THE TEMPORARY INTERCONNECT CABLE OR RADIO SHALL BE INCIDENTAL TO THE COST OF TEMPORARY TRAFFIC SIGNAL INSTALLATION.
3. THE PHASING SHALL BE DEACTIVATED AS REQUIRED DURING CONSTRUCTION STAGING.
4. THE EMERGENCY VEHICLE PREEMPTION SEQUENCE SHALL BE MODIFIED AS REQUIRED DURING CONSTRUCTION STAGING.
5. LED SIGNAL HEADS SHALL BE USED FOR ALL TEMPORARY TRAFFIC SIGNALS.

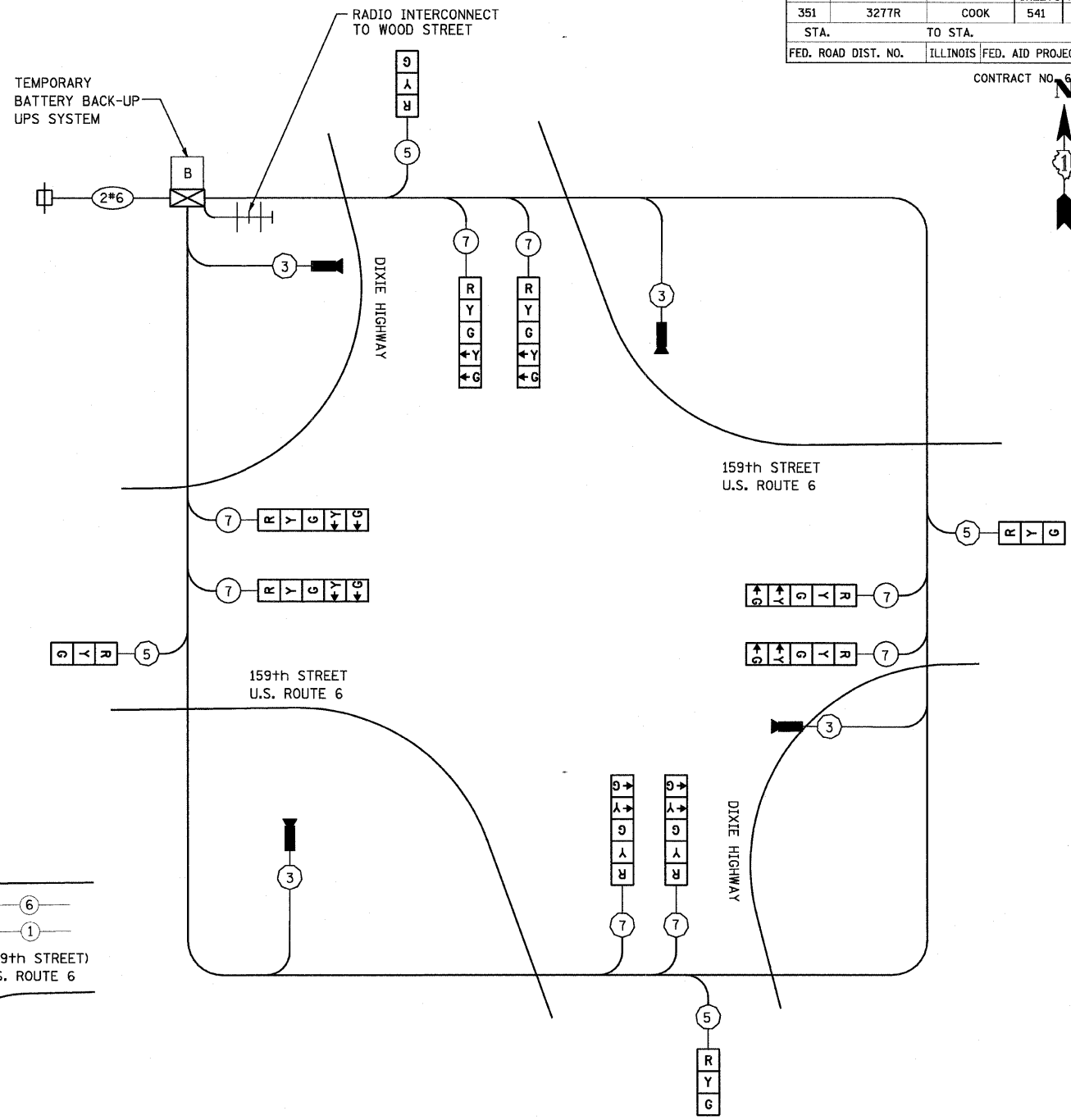

TEMPORARY CONTROLLER SEQUENCE

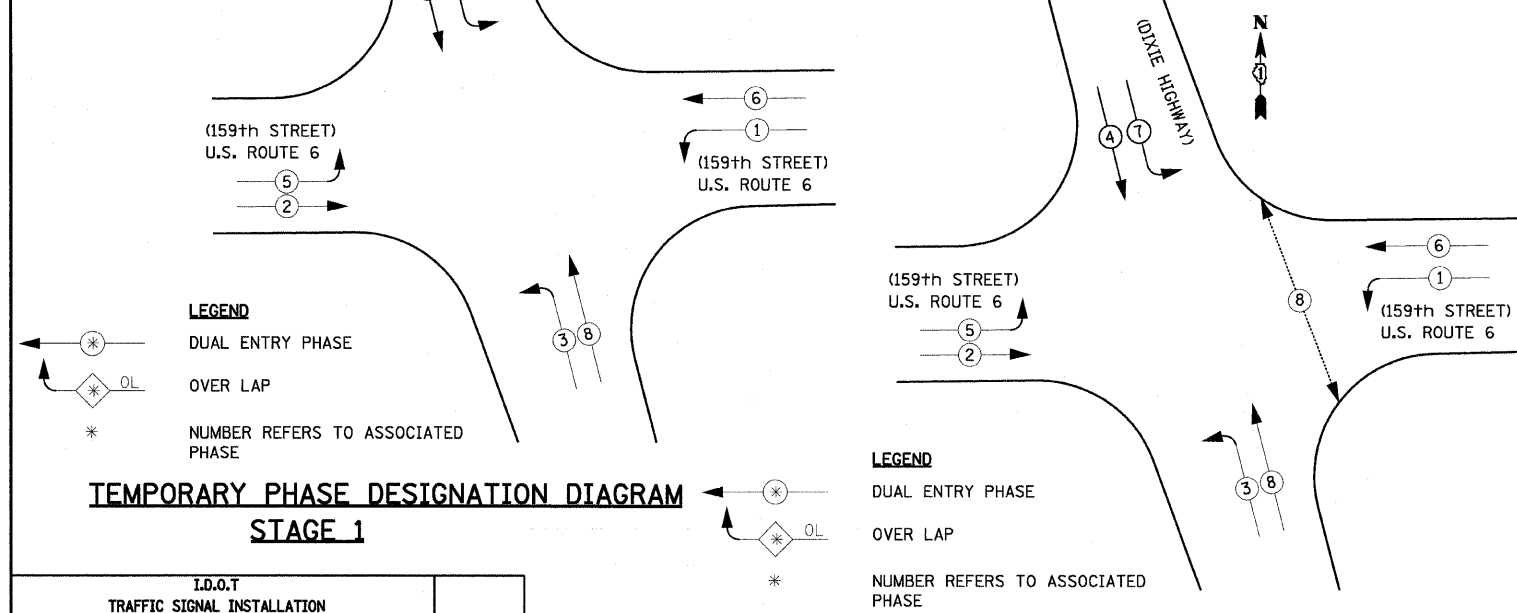

TEMPORARY PHASE DESIGNATION DIAGRAM
STAGE 1

TEMPORARY PHASE DESIGNATION DIAGRAM
STAGE 2

I.D.O.T TRAFFIC SIGNAL INSTALLATION ELECTRICAL SERVICE REQUIREMENTS					TOTAL WATTAGE
TYPE	NO. LAMPS	WATTAGE (INCAND.)	WATTAGE (LED)	% OPERATION	
SIGNAL (RED)	12	135	17	0.50	102.00
(YELLOW)	12	135	12	0.25	36.00
(GREEN)	12	135	12	0.25	36.00
ARROW	16	135	8	0.10	12.80
PED. SIGNAL	0	90	12	1.00	0.00
CONTROLLER	1	100	100	1.00	100.00
ILLUM. SIGN		84		0.05	
FLASHER				0.50	
ENERGY COSTS TO:				TOTAL =	286.8

NOTE:
THE TRAFFIC SIGNAL CONTROLLER EQUIPMENT FOR THIS PROJECT SHALL BE "EAGLE" TO MATCH THE EXISTING ADJACENT SYSTEM.

FOUNDATION (DEPTH)	FT. (m)	CABLE SLACK	FT. (m)	VERTICAL	FT. (m)
TYPE A - POST	4 (1.2)	HANDHOLE	6.5 (2.0)	ALL FOUNDATIONS	3.5 (1.0)
D - CONTROLLER	4 (1.2)	DOUBLE HANDHOLE	13 (4.0)	MAST ARM (L) POLE	20'-H-2'-
E - M. ARM POLE		SIGNAL POST	2 (0.6)	(6m+L-0.6m)=	
30" (750mm)	13.5 (4.1)	CONTROLLER CAB.	1 (0.5)	BRACKET MOUNTED	13 (4.0)
36" (900mm)	11 (3.4)	FIBER OPTIC	13 (4.0)	PED. PUSHBUTTON	4 (1.2)
36" (900mm)	13 (4.0)	ELECTRIC SERVICE	1 (0.5)	ELECTRIC SERVICE	13.5 (4.1)
36" (900mm)	15 (4.6)	GROUND CABLE	1 (0.5)	SERVICE TO GROUND	13.5 (4.1)
				POST MOUNTED	6 (1.8)

ILLINOIS DEPARTMENT OF TRANSPORTATION
201 WEST CENTER COURT
SCHLAUBURG, ILLINOIS 60196-1096
CONTACT: MIKE LYNCH
PHONE: (847) 816-5331
COMPANY: COM. EDISON

Delta Engineering, Inc.
CONSULTING ENGINEERS, CHICAGO, ILLINOIS

REVISIONS	
NAME	DATE

ILLINOIS DEPARTMENT OF TRANSPORTATION
US RTE 6 FROM I-294 TO IL RTE 1

TEMPORARY CABLE PLAN
US RTE 6 & DIXIE HIGHWAY

SCALE: NONE
DATE 01/28/09

DRAWN BY DK
CHECKED BY JA

F.A. RTE.	SECTION	COUNTY	TOTAL SHEETS	SHEET NO.
351	327TR	COOK	541	303
STA. 1+000		TO STA. 1+150		
FED. ROAD DIST. NO.		ILLINOIS FED. AID PROJECT		

CONTRACT NO. 60774

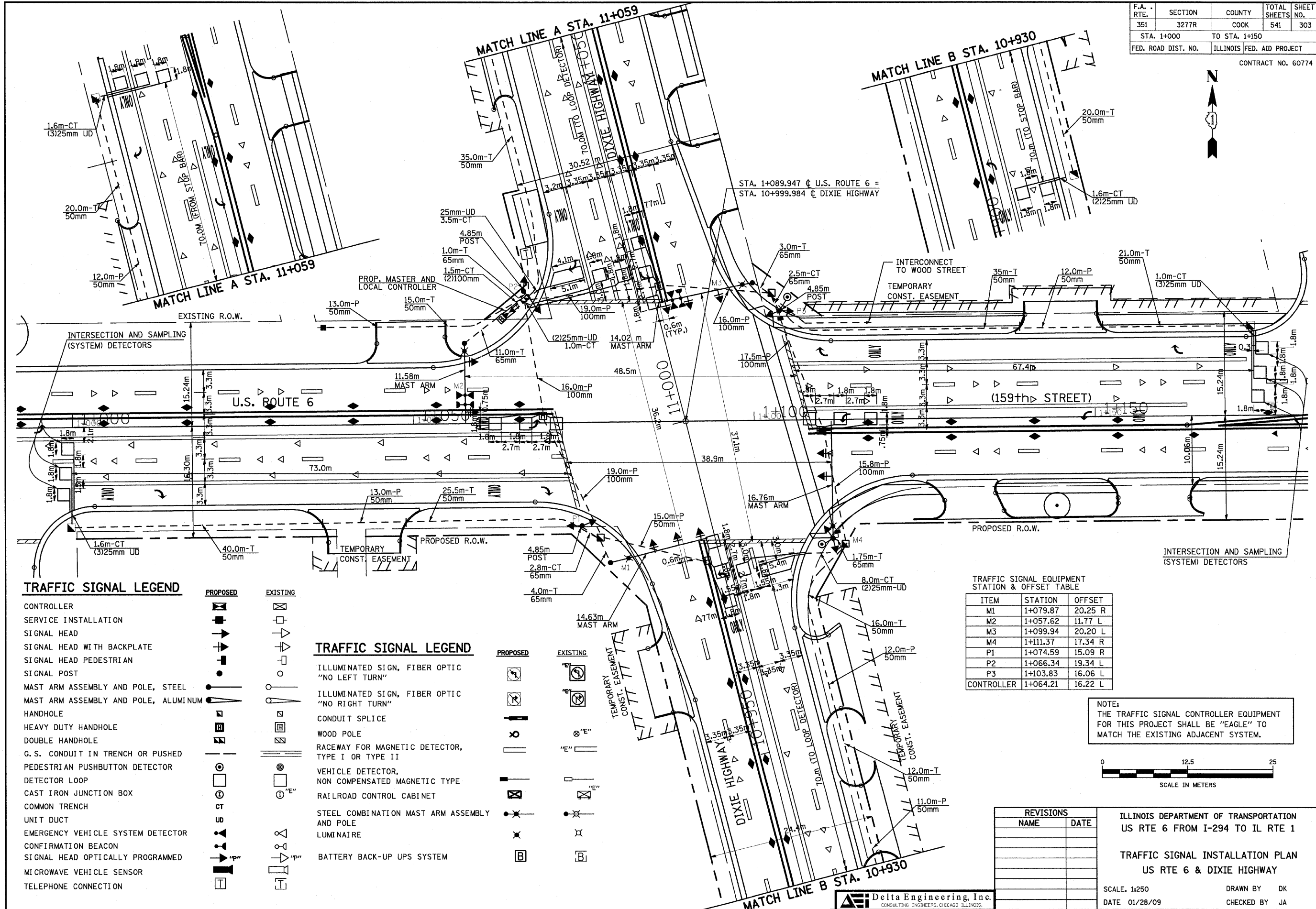

TRAFFIC SIGNAL LEGEND

	PROPOSED	EXISTING
CONTROLLER	[Symbol]	[Symbol]
SERVICE INSTALLATION	[Symbol]	[Symbol]
SIGNAL HEAD	[Symbol]	[Symbol]
SIGNAL HEAD WITH BACKPLATE	[Symbol]	[Symbol]
SIGNAL HEAD PEDESTRIAN	[Symbol]	[Symbol]
SIGNAL POST	[Symbol]	[Symbol]
MAST ARM ASSEMBLY AND POLE, STEEL	[Symbol]	[Symbol]
MAST ARM ASSEMBLY AND POLE, ALUMINUM	[Symbol]	[Symbol]
HANDHOLE	[Symbol]	[Symbol]
HEAVY DUTY HANDHOLE	[Symbol]	[Symbol]
DOUBLE HANDHOLE	[Symbol]	[Symbol]
G. S. CONDUIT IN TRENCH OR PUSHED	[Symbol]	[Symbol]
PEDESTRIAN PUSHBUTTON DETECTOR	[Symbol]	[Symbol]
DETECTOR LOOP	[Symbol]	[Symbol]
CAST IRON JUNCTION BOX	[Symbol]	[Symbol]
COMMON TRENCH	[Symbol]	[Symbol]
UNIT DUCT	[Symbol]	[Symbol]
EMERGENCY VEHICLE SYSTEM DETECTOR	[Symbol]	[Symbol]
CONFIRMATION BEACON	[Symbol]	[Symbol]
SIGNAL HEAD OPTICALLY PROGRAMMED	[Symbol]	[Symbol]
MICROWAVE VEHICLE SENSOR	[Symbol]	[Symbol]
TELEPHONE CONNECTION	[Symbol]	[Symbol]

TRAFFIC SIGNAL LEGEND

	PROPOSED	EXISTING
ILLUMINATED SIGN, FIBER OPTIC "NO LEFT TURN"	[Symbol]	[Symbol]
ILLUMINATED SIGN, FIBER OPTIC "NO RIGHT TURN"	[Symbol]	[Symbol]
CONDUIT SPLICE	[Symbol]	[Symbol]
WOOD POLE	[Symbol]	[Symbol]
RACEWAY FOR MAGNETIC DETECTOR, TYPE I OR TYPE II	[Symbol]	[Symbol]
VEHICLE DETECTOR, NON COMPENSATED MAGNETIC TYPE	[Symbol]	[Symbol]
RAILROAD CONTROL CABINET	[Symbol]	[Symbol]
STEEL COMBINATION MAST ARM ASSEMBLY AND POLE	[Symbol]	[Symbol]
LUMINAIRE	[Symbol]	[Symbol]
BATTERY BACK-UP UPS SYSTEM	[Symbol]	[Symbol]

TRAFFIC SIGNAL EQUIPMENT STATION & OFFSET TABLE

ITEM	STATION	OFFSET
M1	1+079.87	20.25 R
M2	1+057.62	11.77 L
M3	1+099.94	20.20 L
M4	1+111.37	17.34 R
P1	1+074.59	15.09 R
P2	1+066.34	19.34 L
P3	1+103.83	16.06 L
CONTROLLER	1+064.21	16.22 L

NOTE: THE TRAFFIC SIGNAL CONTROLLER EQUIPMENT FOR THIS PROJECT SHALL BE "EAGLE" TO MATCH THE EXISTING ADJACENT SYSTEM.

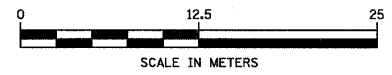

REVISIONS	
NAME	DATE

ILLINOIS DEPARTMENT OF TRANSPORTATION
 US RTE 6 FROM I-294 TO IL RTE 1
TRAFFIC SIGNAL INSTALLATION PLAN
 US RTE 6 & DIXIE HIGHWAY
 SCALE: 1:250
 DATE 01/28/09
 DRAWN BY DK
 CHECKED BY JA

SCHEDULE OF QUANTITIES

PAY ITEM	UNIT	QUANTITY
HANDHOLE	EACH	7
HEAVY-DUTY HANDHOLE	EACH	4
DOUBLE HANDHOLE	EACH	1
FULL-ACTUATED CONTROLLER AND TYPE V CABINET(SPECIAL)	EACH	1
TRANSCEIVER-FIBER OPTIC	EACH	1
TRAFFIC SIGNAL BACKPLATE	EACH	12
INDUCTIVE LOOP DETECTOR	EACH	13
*LIGHT DETECTOR	EACH	2
*LIGHT DETECTOR AMPLIFIER	EACH	1
PEDESTRIAN PUSH-BUTTON	EACH	2
TEMPORARY TRAFFIC SIGNAL INSTALLATION	EACH	1
REMOVE EXISTING TRAFFIC SIGNAL EQUIPMENT	EACH	1
REMOVE EXISTING HANDHOLE	EACH	8
REMOVE EXISTING CONCRETE FOUNDATION	EACH	9
SIGN PANEL - TYPE 1	SQ M	1.4
SIGN PANEL - TYPE 2	SQ M	2.1
CONDUIT IN TRENCH, 50MM DIA., GALVANIZED STEEL	METER	240
CONDUIT IN TRENCH, 65MM DIA., GALVANIZED STEEL	METER	28
CONDUIT IN TRENCH, 100MM DIA., GALVANIZED STEEL	METER	3
CONDUIT PUSHED, 50MM DIA., GALVANIZED STEEL	METER	92
CONDUIT PUSHED, 100MM DIA., GALVANIZED STEEL	METER	103
CONDUIT PUSHED, 125MM DIA., GALVANIZED STEEL	METER	47
TRENCH AND BACKFILL FOR ELECTRICAL WORK	METER	12
ELECTRIC CABLE IN CONDUIT, SIGNAL NO. 14 2C	METER	171
ELECTRIC CABLE IN CONDUIT, SIGNAL NO. 14 3C	METER	173
ELECTRIC CABLE IN CONDUIT, SIGNAL NO. 14 5C	METER	456
ELECTRIC CABLE IN CONDUIT, SIGNAL NO. 14 7C	METER	863
ELECTRIC CABLE IN CONDUIT, LEAD IN NO 4 1PAIR	METER	1458
ELECTRIC CABLE IN CONDUIT, SERVICE, NO. 6 2C	METER	38
TRAFFIC SIGNAL POST, GALVANIZED STEEL 4.85 METER	EACH	3
STEEL COMBINATION MAST ARM ASSEMBLY AND POLE, 7.92 METER	EACH	1
STEEL COMBINATION MAST ARM ASSEMBLY AND POLE, 9.75 METER	EACH	1
STEEL COMBINATION MAST ARM ASSEMBLY AND POLE, 10.36 METER	EACH	1
STEEL COMBINATION MAST ARM ASSEMBLY AND POLE, 13.41 METER	EACH	1
CONCRETE FOUNDATION, TYPE A	METER	3.6
CONCRETE FOUNDATION, TYPE D	METER	1.2
CONCRETE FOUNDATION, TYPE E 750 MM DIAMETER	METER	18.4
PREFORMED DETECTOR LOOP	METER	318
ELECTRIC CABLE IN CONDUIT, GROUNDING, NO. 6 1C	METER	182
ELECTRIC CABLE IN CONDUIT, NO. 20 3/C, TWISTED, SHIELDED	METER	104
TELEPHONE SERVICE INSTALLATION	L.SUM	0.5
SERVICE INSTALLATION, POLE MOUNT	EACH	1
SIGNAL HEAD, LED, 1-FACE, 3-SECTION, MAST ARM MOUNTED	EACH	5
SIGNAL HEAD, LED, 1-FACE, 5-SECTION, MAST ARM MOUNTED	EACH	7
SIGNAL HEAD, LED, 2-FACE, 5-SECTION, BRACKET MOUNTED	EACH	3
SIGNAL HEAD, LED, 2-FACE, 1-3 SECTION, 1-5 SECTION, BRACKET MOUNTED	EACH	1
PEDESTRIAN SIGNAL HEAD, LED, 1-FACE, BRACKET MOUNTED WITH COUNTDOWN TIMER	EACH	2
TEMPORARY TRAFFIC SIGNAL TIMING	EACH	1
UNINTERRUPTABLE POWER SUPPLY	EACH	1

*50% cost to City of Harvey and 50% cost to City of Markham

I.D.O.T TRAFFIC SIGNAL INSTALLATION ELECTRICAL SERVICE REQUIREMENTS					TOTAL WATTAGE
TYPE	NO. LAMPS*	WATTAGE INCAND.	WATTAGE LED	*OPERATION	
SIGNAL (RED)	20	135	17	0.50	170.0
(YELLOW)	20	135	25	0.25	125.0
(GREEN)	20	135	15	0.25	75.0
ARROW	28	135	12	0.10	33.6
PED. SIGNAL	2	90	25	1.00	50.0
CONTROLLER	1	100	100	1.00	100.0
ILLUM. SIGN		84		0.05	

FLASHER		0.50	
ENERGY COSTS TO:	TOTAL =	553.600	
ILLINOIS DEPARTMENT OF TRANSPORTATION 201 WEST CENTER COURT SCHAUMBURG, ILLINOIS 60196-1096			
ENERGY SUPPLY	CONTACT: MIKE LYNCH		
	PHONE: (847) 816-5331		
	COMPANY: COM. EDISON		

CABLE PLAN LEGEND

- | | | | |
|--|--|--|--|
| | G 8" (200mm) TRAFFIC SIGNAL SECTION | | R 12" (300mm) TRAFFIC SIGNAL SECTION |
| | W 12" (300mm) PEDESTRIAN SIGNAL SECTION | | W 12" (300mm) PEDESTRIAN SIGNAL SECTION |
| | W 12" (300mm) PEDESTRIAN SIGNAL SECTION | | "E" RAILROAD CONTROL CABINET |
| | OO COUNTDOWN PEDESTRIAN SIGNAL HEAD | | "E" ILLUMINATED SIGN, L.E.D. "NO LEFT TURN" |
| | ☒ CONTROLLER CABINET | | "E" ILLUMINATED SIGN, L.E.D. "NO RIGHT TURN" |
| | ☐ SERVICE INSTALLATION | | H/C GROUND ROD AT HANDHOLE (H), DOUBLE HANDHOLE (H), OR CONTROLLER (C). |
| | T TELEPHONE CONNECTION | | P GROUND ROD AT POST (P), OR MAST ARM POLE (MA). |
| | ☐ MAGNETIC DETECTOR | | S GROUND ROD AT ELECTRIC SERVICE INSTALLATION |
| | ☐ EMERGENCY VEHICLE LIGHT DETECTOR | | ① GROUND CABLE IN CONDUIT NO. 6 SOLID COPPER (GREEN) |
| | ☐ CONFIRMATION BEACON | | ②④ FIBER OPTIC CABLE IN CONDUIT NO. 62.5/125 MM12F SM12F |
| | ⊙ PUSHBUTTON DETECTOR | | ☐ MICROWAVE VEHICLE SENSOR |
| | ☐ VEHICLE DETECTOR, INDUCTION LOOP | | ☐ BATTERY BACK-UP UPS SYSTEM |
| | ② DENOTES NUMBER OF CONDUCTORS, ALL CABLE NO. 14 EXCEPT AS INDICATED. ALL LOOP DETECTOR CABLE TO BE SHIELDED. | | |

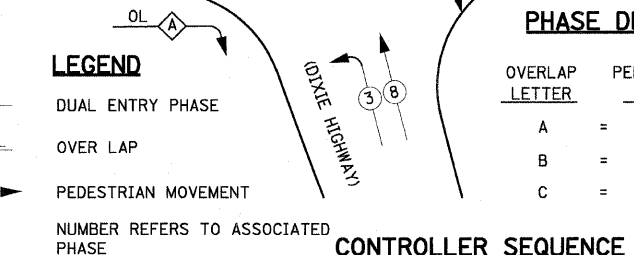
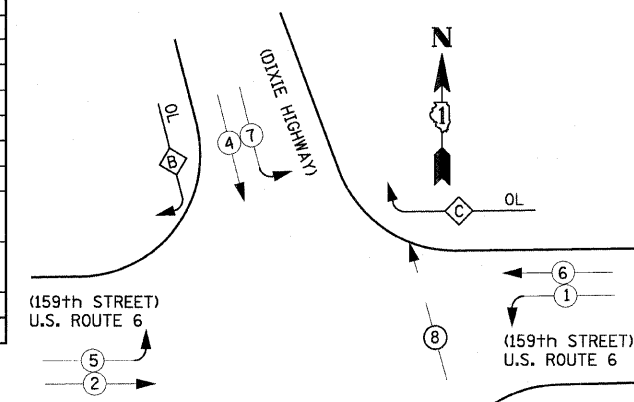

FOUNDATION (DEPTH)	FT. (m)	CABLE SLACK	FT. (m)	VERTICAL	FT. (m)
TYPE A - POST	4 (1.2)	HANDHOLE	6.5 (2.0)	ALL FOUNDATIONS	3.5 (1.0)
D - CONTROLLER	4 (1.2)	DOUBLE HANDHOLE	13 (4.0)	MAST ARM (L) POLE	20'-H-2" (6m+H-0.6m)
E - M. ARM POLE		SIGNAL POST	2 (1.0)	BRACKET MOUNTED	13 (4.0)
	30" (750mm)	CONTROLLER CAB.	1 (0.5)	PED. PUSHBUTTON	4 (1.2)
	36" (900mm)	FIBER OPTIC	13 (4.0)	ELECTRIC SERVICE	13.5 (4.1)
	36" (900mm)	ELECTRIC SERVICE	1 (0.5)	SERVICE TO GROUND	13.5 (4.1)
	36" (900mm)	GROUND CABLE	1 (0.5)	POST MOUNTED	6 (1.8)

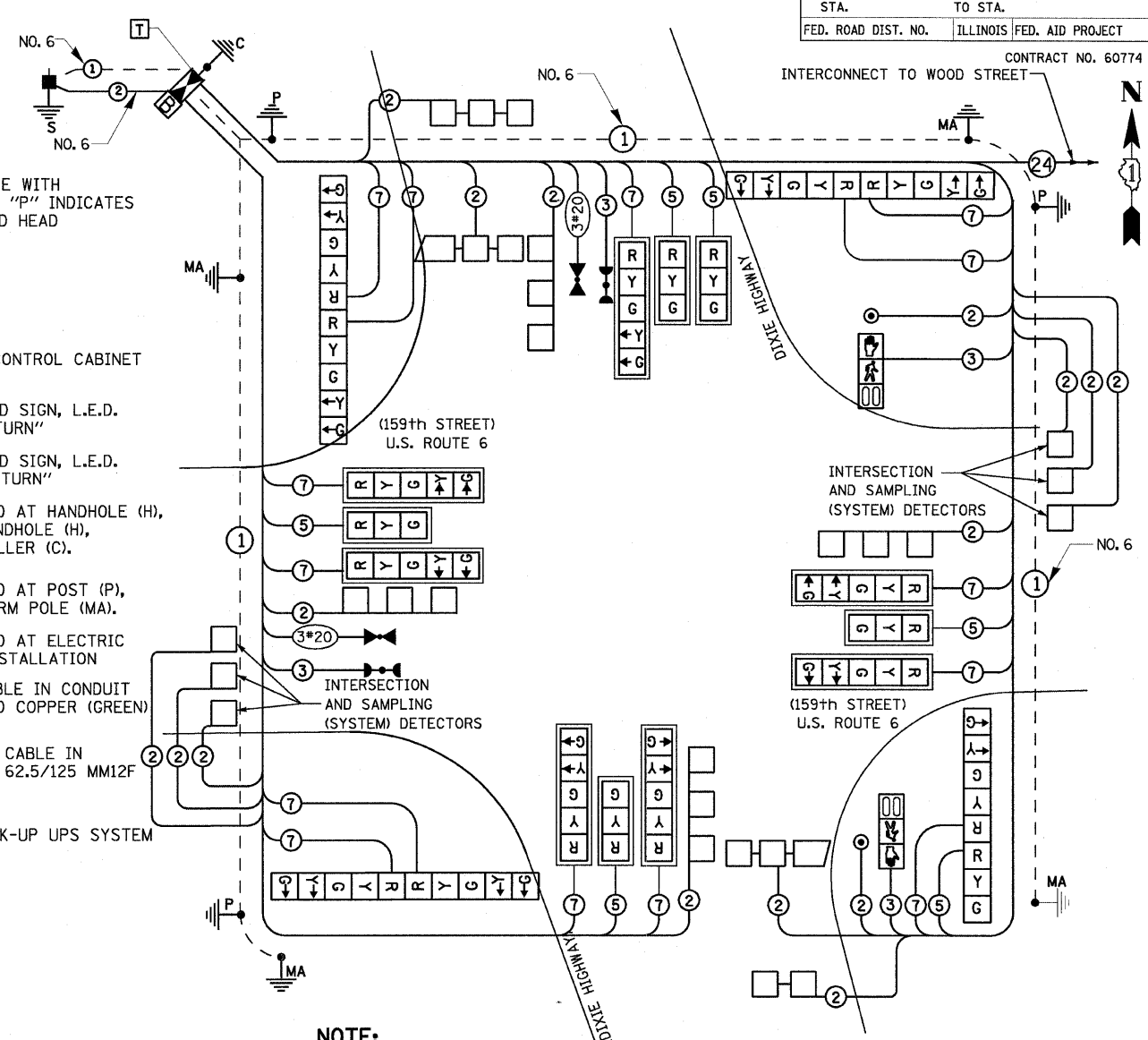

NOTE:
BOTH PUSHBUTTONS SHALL PLACE A CALL IN PHASE 8.

PROPOSED EMERGENCY VEHICLE PREEMPTOR		
VEHICLE EMERGENCY PREEMPTOR	3	4
MOVEMENT	← →	↑ ↓

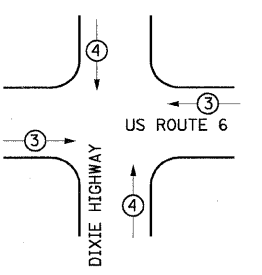

THE TRAFFIC SIGNAL CONTROL EQUIPMENT FOR THIS PROJECT SHALL BE "EAGLE" TO MATCH THE EXISTING ADJACENT SYSTEM.

REVISIONS	
NAME	DATE

ILLINOIS DEPARTMENT OF TRANSPORTATION
US RTE 6 FROM I-294 TO IL RTE 1
SCHEDULE OF QUANTITIES AND CABLE PLAN
US RTE 6 & DIXIE HIGHWAY

SCALE: NONE
DATE 01/28/09

DRAWN BY DK
CHECKED BY JA

F.A. RTE.	SECTION	COUNTY	TOTAL SHEETS	SHEET NO.
351	3277R	COOK	541	305
STA. 1+600		TO STA. 1+750		
FED. ROAD DIST. NO.		ILLINOIS FED. AID PROJECT		

THE FOLLOWING EXISTING TRAFFIC SIGNAL THE FOLLOWING ITEMS SHALL BE REMOVED BY THE CONTRACTOR AND SHALL BE DISPOSED OF BY THEM OUTSIDE THE RIGHT-OF-WAY AT THEIR EXPENSE. THE SALVAGE VALUE OF THE REMOVED EQUIPMENT SHALL BE REFLECTED IN THE CONTRACT BID PRICE.

- 1 EACH CONTROLLER AND CABINET (COMPLETE)
- 4 EACH ALUMINUM MAST ARM ASSEMBLY AND POLE
- 8 EACH SIGNAL HEAD, 1 - FACE
- 4 EACH SIGNAL HEAD, 2 - FACE
- 8 EACH PEDESTRIAN HEAD, 1 - FACE
- 4 EACH PEDESTRIAN PUSHBUTTON
- 1 EACH SERVICE INSTALLATION
- 4 EACH TRAFFIC SIGNAL POST
- 4 EACH TRAFFIC SIGNAL BACKPLATE

EXISTING EQUIPMENT TO BE REMOVED LEGEND

- EXISTING SIGNAL HEAD TO BE REMOVED
- EXISTING SERVICE INSTALLATION TO BE REMOVED
- EXISTING CONTROLLER TO BE REMOVED
- EXISTING HANDHOLE TO BE REMOVED
- EXISTING PEDESTRIAN SIGNAL HEAD TO BE REMOVED
- EXISTING PEDESTRIAN PUSH BUTTON TO BE REMOVED
- EMERGENCY VEHICLE LIGHT DETECTOR TO BE REMOVED
- CONFIRMATION BEACON TO BE REMOVED
- EXISTING HEAVY-DUTY HANDHOLE TO BE REMOVED
- EXISTING SIGNAL POST AND FOUNDATION TO BE REMOVED
- EXISTING ALUMINUM MAST ARM POLE AND FOUNDATION TO BE REMOVED
- EXISTING STEEL MAST ARM POLE AND FOUNDATION TO BE REMOVED
- EXISTING STEEL COMBINATION MAST ARM POLE AND FOUNDATION TO BE REMOVED

CONTRACT NO. 60774

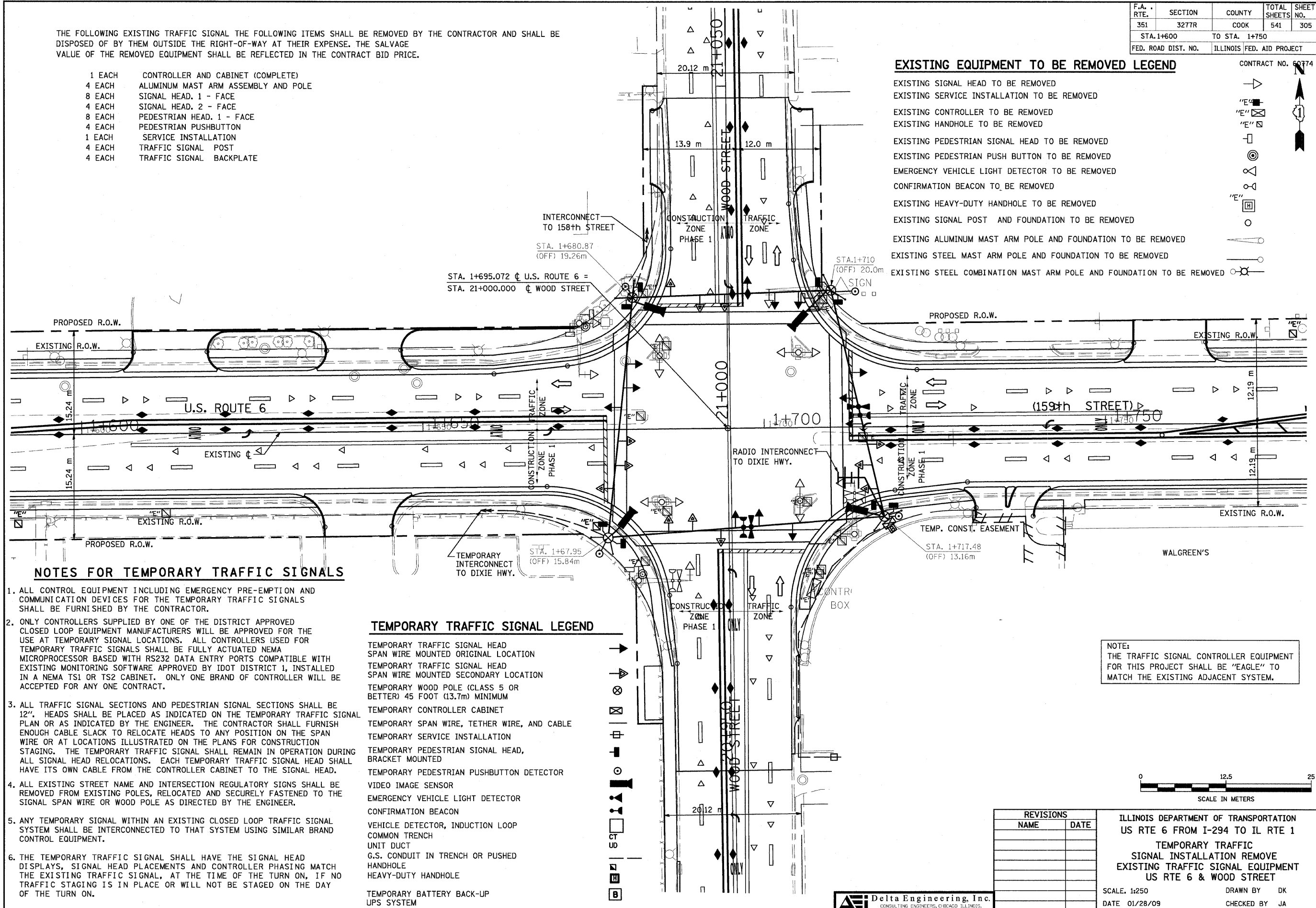

NOTES FOR TEMPORARY TRAFFIC SIGNALS

1. ALL CONTROL EQUIPMENT INCLUDING EMERGENCY PRE-EMPTION AND COMMUNICATION DEVICES FOR THE TEMPORARY TRAFFIC SIGNALS SHALL BE FURNISHED BY THE CONTRACTOR.
2. ONLY CONTROLLERS SUPPLIED BY ONE OF THE DISTRICT APPROVED CLOSED LOOP EQUIPMENT MANUFACTURERS WILL BE APPROVED FOR THE USE AT TEMPORARY SIGNAL LOCATIONS. ALL CONTROLLERS USED FOR TEMPORARY TRAFFIC SIGNALS SHALL BE FULLY ACTUATED NEMA MICROPROCESSOR BASED WITH RS232 DATA ENTRY PORTS COMPATIBLE WITH EXISTING MONITORING SOFTWARE APPROVED BY IDOT DISTRICT 1, INSTALLED IN A NEMA TS1 OR TS2 CABINET. ONLY ONE BRAND OF CONTROLLER WILL BE ACCEPTED FOR ANY ONE CONTRACT.
3. ALL TRAFFIC SIGNAL SECTIONS AND PEDESTRIAN SIGNAL SECTIONS SHALL BE 12". HEADS SHALL BE PLACED AS INDICATED ON THE TEMPORARY TRAFFIC SIGNAL PLAN OR AS INDICATED BY THE ENGINEER. THE CONTRACTOR SHALL FURNISH ENOUGH CABLE SLACK TO RELOCATE HEADS TO ANY POSITION ON THE SPAN WIRE OR AT LOCATIONS ILLUSTRATED ON THE PLANS FOR CONSTRUCTION STAGING. THE TEMPORARY TRAFFIC SIGNAL SHALL REMAIN IN OPERATION DURING ALL SIGNAL HEAD RELOCATIONS. EACH TEMPORARY TRAFFIC SIGNAL HEAD SHALL HAVE ITS OWN CABLE FROM THE CONTROLLER CABINET TO THE SIGNAL HEAD.
4. ALL EXISTING STREET NAME AND INTERSECTION REGULATORY SIGNS SHALL BE REMOVED FROM EXISTING POLES, RELOCATED AND SECURELY FASTENED TO THE SIGNAL SPAN WIRE OR WOOD POLE AS DIRECTED BY THE ENGINEER.
5. ANY TEMPORARY SIGNAL WITHIN AN EXISTING CLOSED LOOP TRAFFIC SIGNAL SYSTEM SHALL BE INTERCONNECTED TO THAT SYSTEM USING SIMILAR BRAND CONTROL EQUIPMENT.
6. THE TEMPORARY TRAFFIC SIGNAL SHALL HAVE THE SIGNAL HEAD DISPLAYS, SIGNAL HEAD PLACEMENTS AND CONTROLLER PHASING MATCH THE EXISTING TRAFFIC SIGNAL, AT THE TIME OF THE TURN ON, IF NO TRAFFIC STAGING IS IN PLACE OR WILL NOT BE STAGED ON THE DAY OF THE TURN ON.

TEMPORARY TRAFFIC SIGNAL LEGEND

- TEMPORARY TRAFFIC SIGNAL HEAD
- SPAN WIRE MOUNTED ORIGINAL LOCATION
- TEMPORARY TRAFFIC SIGNAL HEAD
- SPAN WIRE MOUNTED SECONDARY LOCATION
- TEMPORARY WOOD POLE (CLASS 5 OR BETTER) 45 FOOT (13.7m) MINIMUM
- TEMPORARY CONTROLLER CABINET
- TEMPORARY SPAN WIRE, TETHER WIRE, AND CABLE
- TEMPORARY SERVICE INSTALLATION
- TEMPORARY PEDESTRIAN SIGNAL HEAD, BRACKET MOUNTED
- TEMPORARY PEDESTRIAN PUSHBUTTON DETECTOR
- VIDEO IMAGE SENSOR
- EMERGENCY VEHICLE LIGHT DETECTOR
- CONFIRMATION BEACON
- VEHICLE DETECTOR, INDUCTION LOOP
- COMMON TRENCH
- UNIT DUCT
- G.S. CONDUIT IN TRENCH OR PUSHED
- HANDHOLE
- HEAVY-DUTY HANDHOLE
- TEMPORARY BATTERY BACK-UP UPS SYSTEM

NOTE: THE TRAFFIC SIGNAL CONTROLLER EQUIPMENT FOR THIS PROJECT SHALL BE "EAGLE" TO MATCH THE EXISTING ADJACENT SYSTEM.

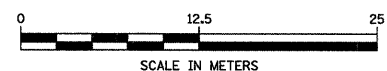

REVISIONS	
NAME	DATE

ILLINOIS DEPARTMENT OF TRANSPORTATION
 US RTE 6 FROM I-294 TO IL RTE 1
 TEMPORARY TRAFFIC
 SIGNAL INSTALLATION REMOVE
 EXISTING TRAFFIC SIGNAL EQUIPMENT
 US RTE 6 & WOOD STREET
 SCALE: 1:250 DRAWN BY DK
 DATE 01/28/09 CHECKED BY JA

TEMPORARY CABLE DIAGRAM LEGEND

- R TEMPORARY TRAFFIC SIGNAL SECTION OR PEDESTRIAN SIGNAL SECTION 12" (300 mm)
- X TEMPORARY CONTROLLER CABINET
- TEMPORARY SERVICE INSTALLATION
- 5 INDICATES NUMBER OF CONDUCTORS IN CABLE. ALL CONDUCTORS TO BE NUMBER 14 AWG WIRE UNLESS OTHERWISE NOTED.
- EMERGENCY VEHICLE LIGHT DETECTOR
- CONFIRMATION BEACON
- PEDESTRIAN PUSHBUTTON DETECTOR
- VEHICLE DETECTOR, INDUCTION LOOP
- 12" (300mm) PEDESTRIAN SIGNAL SECTION
- VIDEO IMAGE SENSOR
- B TEMPORARY BATTERY BACK-UP UPS SYSTEM

CONSTRUCTION NOTES

1. THE EXISTING TRAFFIC RESPONSIVE CLOSED LOOP SYSTEM OPERATION SHALL BE MAINTAINED DURING CONSTRUCTION. THE CONTRACTOR SHALL CONTACT THE S.C.A.T. SYSTEMS ENGINEER, MR. GEORGE BROWN AT (847) 697-6700 AT LEAST 72 HOURS PRIOR TO THE START OF WORK TO REQUEST MODIFICATION OF THE EXISTING TRAFFIC RESPONSIVE PROGRAM. UPON COMPLETION AND ACCEPTANCE OF THE TRAFFIC SIGNAL MODIFICATIONS, THE CONTRACTOR SHALL CONTACT THE SIGNAL SYSTEM ENGINEER TO REQUEST RESTORATION OF THE ORIGINAL TRAFFIC RESPONSIVE PROGRAM.
2. THE CONTRACTOR SHALL MAINTAIN THE EXISTING SIGNAL SYSTEM INTERCONNECT DURING TEMPORARY SIGNAL OPERATION. THE INSTALLATION OF THE TEMPORARY INTERCONNECT CABLE OR RADIO SHALL BE NON-DESTRUCTIVE. THE INSTALLATION AND MAINTENANCE OF THE TEMPORARY INTERCONNECT CABLE OR RADIO SHALL BE INCIDENTAL TO THE COST OF TEMPORARY TRAFFIC SIGNAL INSTALLATION.
3. THE PHASING SHALL BE DEACTIVATED AS REQUIRED DURING CONSTRUCTION STAGING.
4. THE EMERGENCY VEHICLE PREEMPTION SEQUENCE SHALL BE MODIFIED AS REQUIRED DURING CONSTRUCTION STAGING.
5. LED SIGNAL HEADS SHALL BE USED FOR ALL TEMPORARY TRAFFIC SIGNALS.

TEMPORARY CONTROLLER SEQUENCE STAGE 1 AND 2

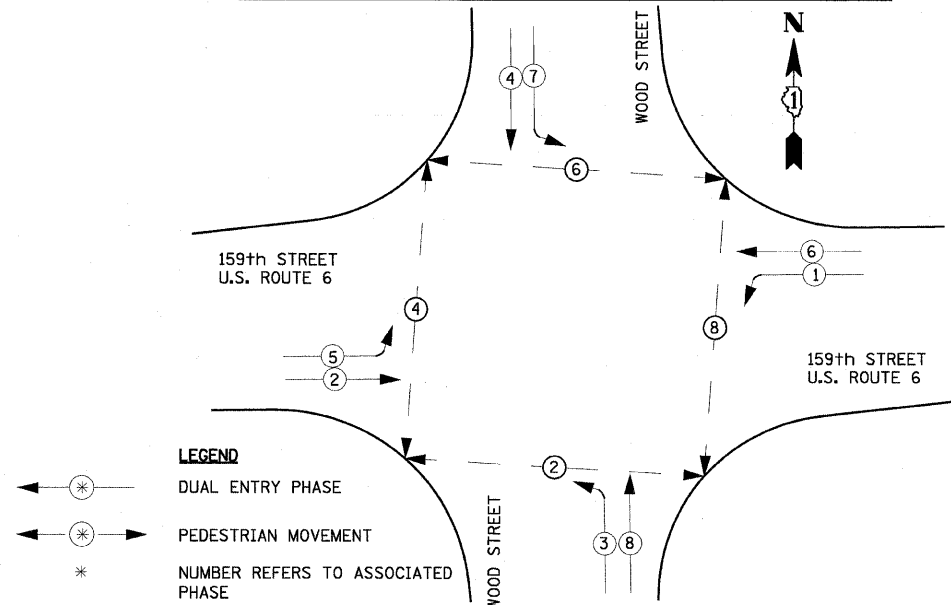

- LEGEND**
- DUAL ENTRY PHASE
 - PEDESTRIAN MOVEMENT
 - * NUMBER REFERS TO ASSOCIATED PHASE

TEMPORARY PHASE DESIGNATION DIAGRAM STAGE 1 AND 2

PROPOSED EMERGENCY VEHICLE PREEMPTOR	
VEHICLE EMERGENCY PREEMPTOR	3 4
MOVEMENT	← → ↑ ↓

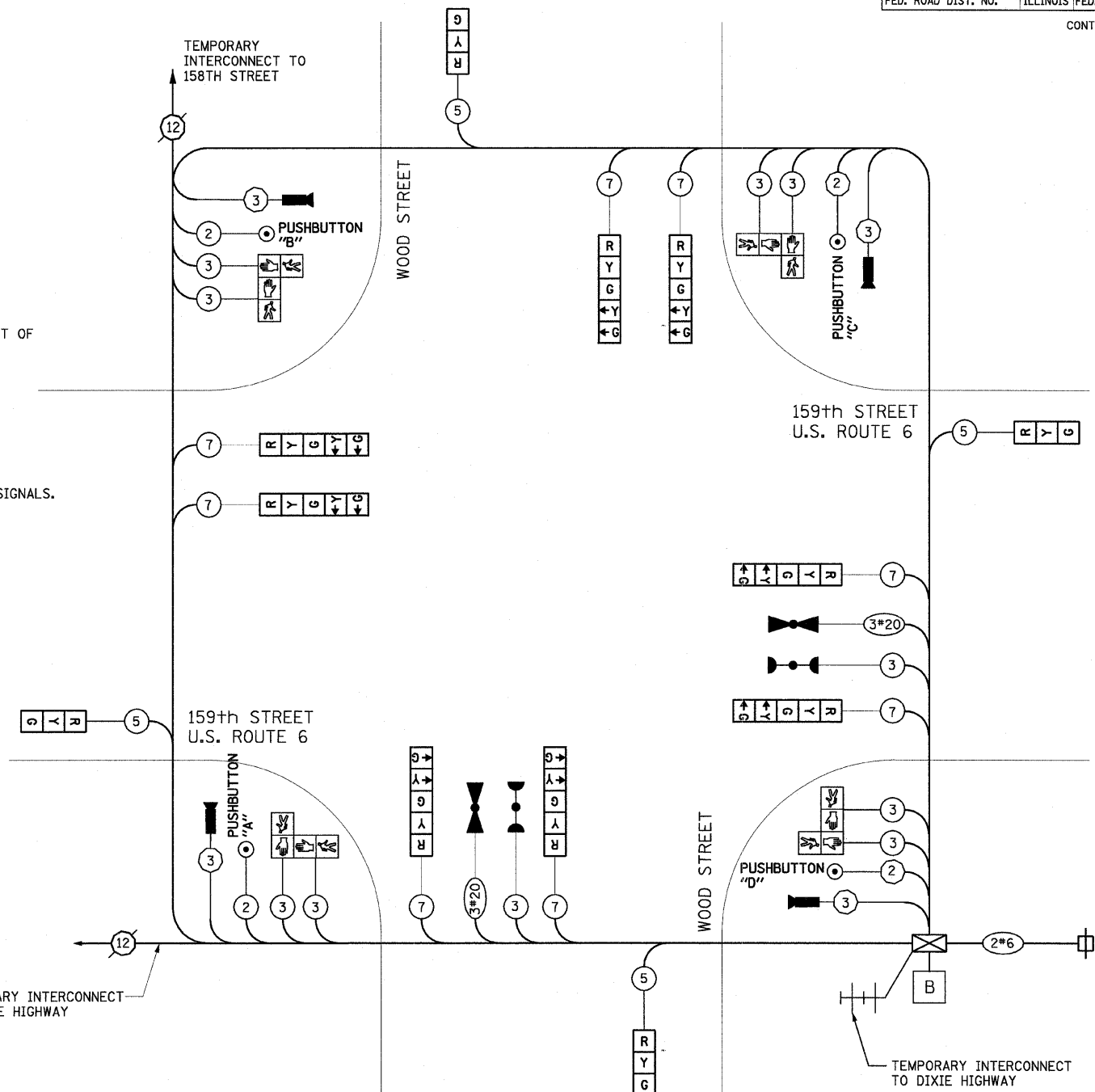
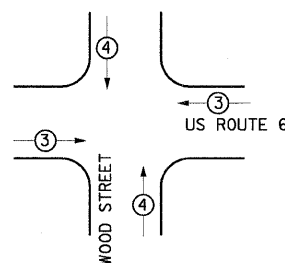

- NOTES:**
- PUSHBUTTON "A" SHALL PLACE A CALL IN PHASES 2 & 4
 - PUSHBUTTON "B" SHALL PLACE A CALL IN PHASES 4 & 6
 - PUSHBUTTON "C" SHALL PLACE A CALL IN PHASES 6 & 8
 - PUSHBUTTON "D" SHALL PLACE A CALL IN PHASES 2 & 8

NOTE:
THE TRAFFIC SIGNAL CONTROLLER EQUIPMENT FOR THIS PROJECT SHALL BE "EAGLE" TO MATCH THE EXISTING ADJACENT SYSTEM.

I.D.O.T. TRAFFIC SIGNAL INSTALLATION ELECTRICAL SERVICE REQUIREMENTS					TOTAL WATTAGE
TYPE	NO. LAMPS	WATTAGE INCAND.	WATTAGE LED	% OPERATION	
SIGNAL (RED)	12	135	17	0.50	102.00
(YELLOW)	12	135	25	0.25	75.00
(GREEN)	12	135	15	0.25	45.00
ARROW	16	135	12	0.10	19.20
PED. SIGNAL	8	90	25	1.00	200.0
CONTROLLER	1	100	100	1.00	100.00
ILLUM. SIGN		84		0.05	
FLASHER				0.50	
ENERGY COSTS TO:				TOTAL =	541.2

ILLINOIS DEPARTMENT OF TRANSPORTATION
201 WEST CENTER COURT
SCHAUMBURG, ILLINOIS 60196-1096
CONTACT: MIKE LYNCH
PHONE: (847) 816-5331
COMPANY: COM. EDISON

FOUNDATION (DEPTH)	FT. (m)	CABLE SLACK	FT. (m)	VERTICAL	FT. (m)
TYPE A - POST	4 (1.2)	HANDHOLE	6.5 (2.0)	ALL FOUNDATIONS	3.5 (1.0)
D - CONTROLLER	4 (1.2)	DOUBLE HANDHOLE	13 (4.0)	MAST ARM (L) POLE	20'-H-2" (6m+L-0.6m)
E - M. ARM POLE		SIGNAL POST	2 (0.6)	BRACKET MOUNTED	13 (4.0)
	30" (750mm)	CONTROLLER CAB.	1 (0.3)	PED. PUSHBUTTON	4 (1.2)
	36" (900mm)	FIBER OPTIC	13 (4.0)	ELECTRIC SERVICE	13.5 (4.1)
	36" (900mm)	ELECTRIC SERVICE	1 (0.3)	SERVICE TO GROUND	13.5 (4.1)
	36" (900mm)	GROUND CABLE	1 (0.3)	POST MOUNTED	6 (1.8)

REVISIONS	
NAME	DATE

ILLINOIS DEPARTMENT OF TRANSPORTATION
US RTE 6 FROM I-294 TO IL RTE 1

**TEMPORARY CABLE PLAN
US RTE 6 & WOOD STREET**

SCALE: NONE
DATE 01/28/09
DRAWN BY DK
CHECKED BY JA

F.A. RTE.	SECTION	COUNTY	TOTAL SHEETS	SHEET NO.
351	3277R	COOK	541	307
STA. 1+600		TO STA. 1+750		
FED. ROAD DIST. NO.		ILLINOIS FED. AID PROJECT		
CONTRACT NO. 60774				

TRAFFIC SIGNAL EQUIPMENT STATION & OFFSET TABLE

ITEM	STATION	OFFSET
M1	1+679.61	16.75 R
M2	1+677.79	15.46 L
M3	1+711.52	16.75 L
M4	1+712.00	15.25 R
CONTROLLER	1+713.89	14.88 R

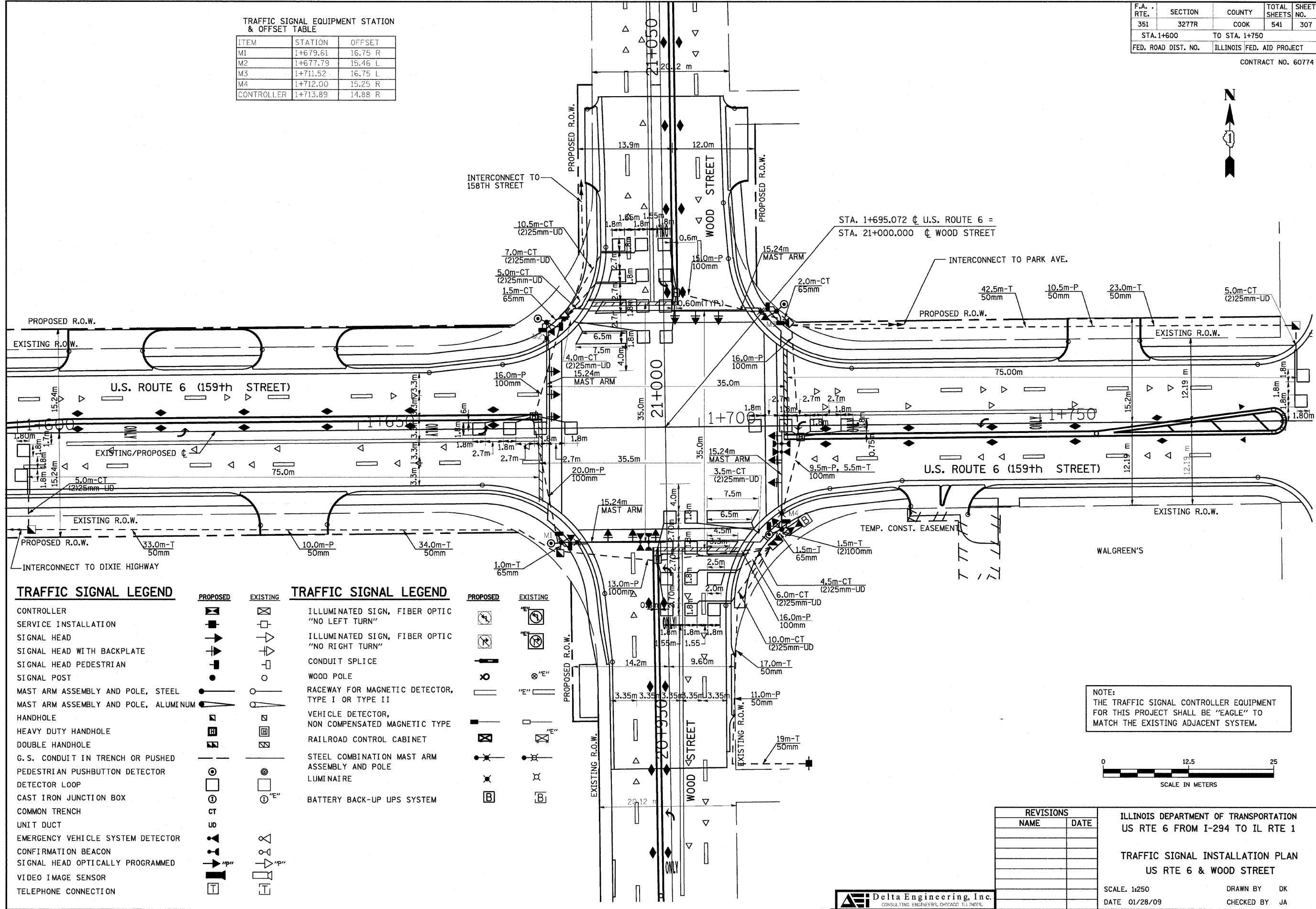

TRAFFIC SIGNAL LEGEND

CONTROLLER		
SERVICE INSTALLATION		
SIGNAL HEAD		
SIGNAL HEAD WITH BACKPLATE		
SIGNAL HEAD PEDESTRIAN		
SIGNAL POST		
MAST ARM ASSEMBLY AND POLE, STEEL		
MAST ARM ASSEMBLY AND POLE, ALUMINUM		
HANDHOLE		
HEAVY DUTY HANDHOLE		
DOUBLE HANDHOLE		
G.S. CONDUIT IN TRENCH OR PUSHED		
PEDESTRIAN PUSHBUTTON DETECTOR		
DETECTOR LOOP		
CAST IRON JUNCTION BOX		
COMMON TRENCH		
UNIT DUCT		
EMERGENCY VEHICLE SYSTEM DETECTOR		
CONFIRMATION BEACON		
SIGNAL HEAD OPTICALLY PROGRAMMED		
VIDEO IMAGE SENSOR		
TELEPHONE CONNECTION		

TRAFFIC SIGNAL LEGEND

ILLUMINATED SIGN, FIBER OPTIC "NO LEFT TURN"		
ILLUMINATED SIGN, FIBER OPTIC "NO RIGHT TURN"		
CONDUIT SPLICE		
WOOD POLE		
RACEWAY FOR MAGNETIC DETECTOR, TYPE I OR TYPE II		
VEHICLE DETECTOR, NON COMPENSATED MAGNETIC TYPE		
RAILROAD CONTROL CABINET		
STEEL COMBINATION MAST ARM ASSEMBLY AND POLE		
LUMINAIRE		
BATTERY BACK-UP UPS SYSTEM		

NOTE:
THE TRAFFIC SIGNAL CONTROLLER EQUIPMENT FOR THIS PROJECT SHALL BE "EAGLE" TO MATCH THE EXISTING ADJACENT SYSTEM.

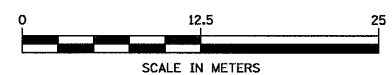

REVISIONS	
NAME	DATE

ILLINOIS DEPARTMENT OF TRANSPORTATION
US RTE 6 FROM I-294 TO IL RTE 1

TRAFFIC SIGNAL INSTALLATION PLAN
US RTE 6 & WOOD STREET

SCALE: 1:250
DATE 01/28/09

DRAWN BY DK
CHECKED BY JA

SCHEDULE OF QUANTITIES

PAY ITEM	UNIT	QTY.
HANDHOLE	EACH	5
HEAVY-DUTY HANDHOLE	EACH	4
DOUBLE HANDHOLE	EACH	1
FULL-ACTUATED CONTROLLER AND TYPE IV CABINET	EACH	1
TRANSCIEVER-FIBER OPTIC	EACH	1
TRAFFIC SIGNAL BACKPLATE	EACH	12
INDUCTIVE LOOP DETECTOR	EACH	8
*LIGHT DETECTOR	EACH	2
*LIGHT DETECTOR AMPLIFIER	EACH	1
PEDESTRIAN PUSH-BUTTON	EACH	4
TEMPORARY TRAFFIC SIGNAL INSTALLATION	EACH	1
REMOVE EXISTING TRAFFIC SIGNAL EQUIPMENT	EACH	1
REMOVE EXISTING HANDHOLE	EACH	15
REMOVE EXISTING CONCRETE FOUNDATION	EACH	9
SIGN PANEL - TYPE 1	SQ M	1.12
SIGN PANEL - TYPE 2	SQ M	2.1
CONDUIT IN TRENCH, 50MM DIA., GALVANIZED STEEL	METER	169
CONDUIT IN TRENCH, 65MM DIA., GALVANIZED STEEL	METER	6
CONDUIT IN TRENCH, 100MM DIA., GALVANIZED STEEL	METER	7
CONDUIT PUSHED, 50MM DIA., GALVANIZED STEEL	METER	32
CONDUIT PUSHED, 100MM DIA., GALVANIZED STEEL	METER	113
TRENCH AND BACKFILL FOR ELECTRICAL WORK	METER	10
ELECTRIC CABLE IN CONDUIT, SIGNAL NO. 14 2C	METER	192
ELECTRIC CABLE IN CONDUIT, SIGNAL NO. 14 3C	METER	243
ELECTRIC CABLE IN CONDUIT, SIGNAL NO. 14 5C	METER	487
ELECTRIC CABLE IN CONDUIT, SIGNAL NO. 14 7C	METER	442
ELECTRIC CABLE IN CONDUIT, LEAD-IN, NO 4 1 PAIR	METER	277
ELECTRIC CABLE IN CONDUIT, SERVICE, NO. 6 2C	METER	55
STEEL COMBINATION MAST ARM ASSEMBLY AND POLE, 11.58 METER	EACH	4
CONCRETE FOUNDATION, TYPE D	METER	1.2
CONCRETE FOUNDATION, TYPE E 750 MM DIAMETER	METER	18.4
PREFORMED DETECTOR LOOP	METER	421
ELECTRIC CABLE IN CONDUIT, GROUNDING, NO. 6 1C	METER	162
ELECTRIC CABLE IN CONDUIT, NO. 20 3/C, TWISTED, SHIELDED	METER	107
SERVICE INSTALLATION, POLE MOUNT	EACH	1
SIGNAL HEAD, LED, 1-FACE, 3-SECTION, MAST ARM MOUNTED	EACH	8
SIGNAL HEAD, LED, 1-FACE, 5-SECTION, BRACKET MOUNTED	EACH	4
SIGNAL HEAD, LED, 1-FACE, 5-SECTION, MAST ARM MOUNTED	EACH	4
PEDESTRIAN SIGNAL HEAD, LED, 2-FACE, BRACKET MOUNTED WITH COUNTDOWN TIMER	EACH	4
TEMPORARY TRAFFIC SIGNAL TIMING	EACH	1
UNINTERRUPTABLE POWER SUPPLY	EACH	1

* 100% cost to City of Harvey

I.D.O.T. TRAFFIC SIGNAL INSTALLATION ELECTRICAL SERVICE REQUIREMENTS					TOTAL WATTAGE
TYPE	NO. LAMPS	WATTAGE INCAND.	WATTAGE LED	% OPERATION	
SIGNAL (RED)	16	135	17	0.50	136.0
(YELLOW)	16	135	25	0.25	100.0
(GREEN)	16	135	15	0.25	60.0
ARROW	16	135	12	0.10	19.2
PED. SIGNAL	8	90	25	1.00	200.0
CONTROLLER	1	100	100	1.00	100.0
ILLUM. SIGN		84		0.05	
TOTAL =					615.20

ENERGY COSTS TO: TOTAL = 615.20
ILLINOIS DEPARTMENT OF TRANSPORTATION
201 WEST CENTER COURT
SCHUMBERG, ILLINOIS 60196-1096
CONTACT: MIKE LYNCH
PHONE: (847) 816-5331
COMPANY: COM. EDISON

FOUNDATION (DEPTH)	FT. (m)	CABLE SLACK	FT. (m)	VERTICAL	FT. (m)
TYPE A - POST	4 (1.2)	HANDHOLE	6.5 (2.0)	ALL FOUNDATIONS	3.5 (1.0)
D - CONTROLLER	4 (1.2)	DOUBLE HANDHOLE	13 (4.0)	MAST ARM (L) POLE	20'+L-2'
E - M. ARM POLE		SIGNAL POST	2 (1.0)	(6m+L-0.6m)=	
30" (750mm)	13.5 (4.1)	CONTROLLER CAB.	1 (0.5)	BRACKET MOUNTED	13 (4.0)
36" (900mm)	11 (3.4)	FIBER OPTIC	13 (4.0)	PED. PUSHBUTTON	4 (1.2)
36" (900mm)	13 (4.0)	ELECTRIC SERVICE	1 (0.5)	ELECTRIC SERVICE	13.5 (4.1)
36" (900mm)	15 (4.6)	GROUND CABLE	1 (0.5)	SERVICE TO GROUND	13.5 (4.1)
				POST MOUNTED	6 (1.8)

CABLE PLAN LEGEND

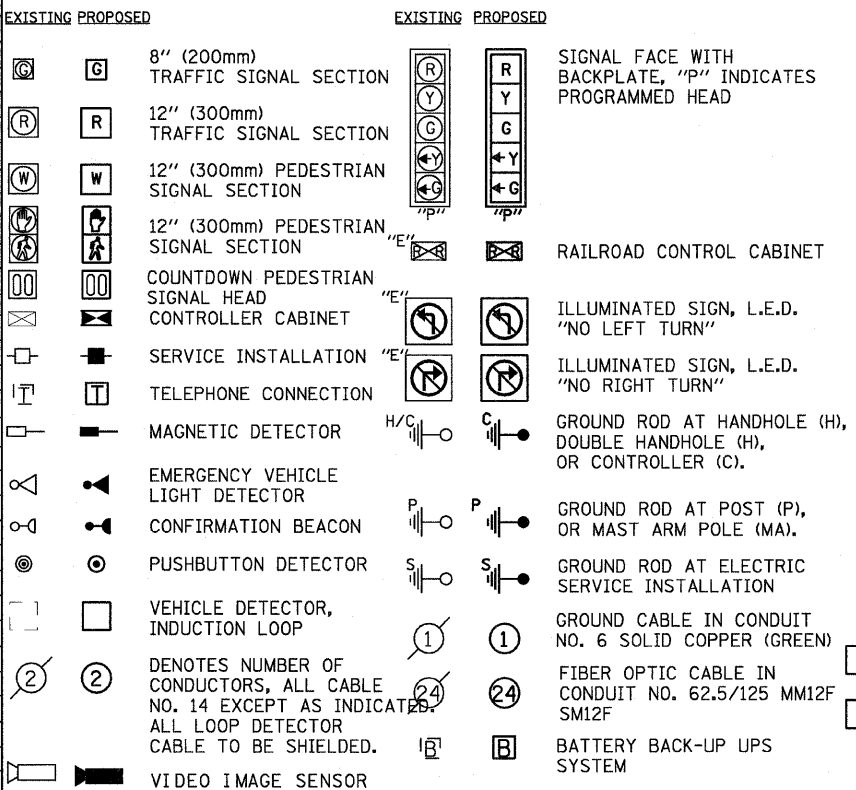

CONTROLLER SEQUENCE

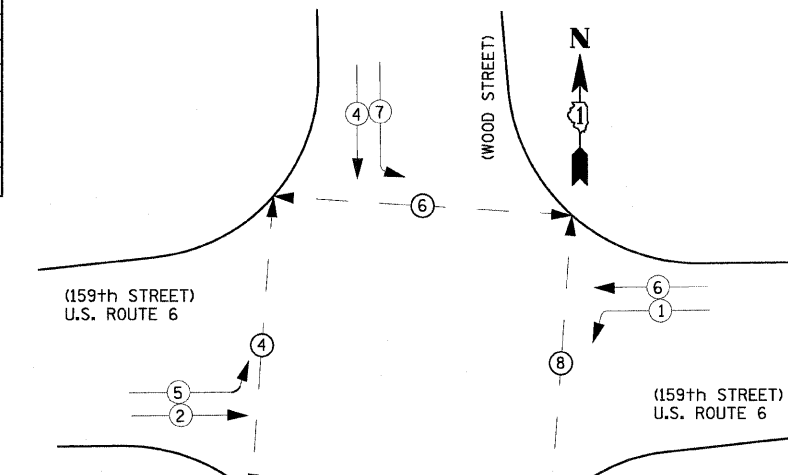

LEGEND

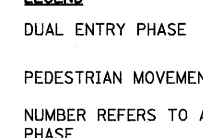

PHASE DESIGNATION DIAGRAM



PROPOSED EMERGENCY VEHICLE PREEMPTOR	
VEHICLE EMERGENCY PREEMPTOR	3 4
MOVEMENT	← → ↑ ↓

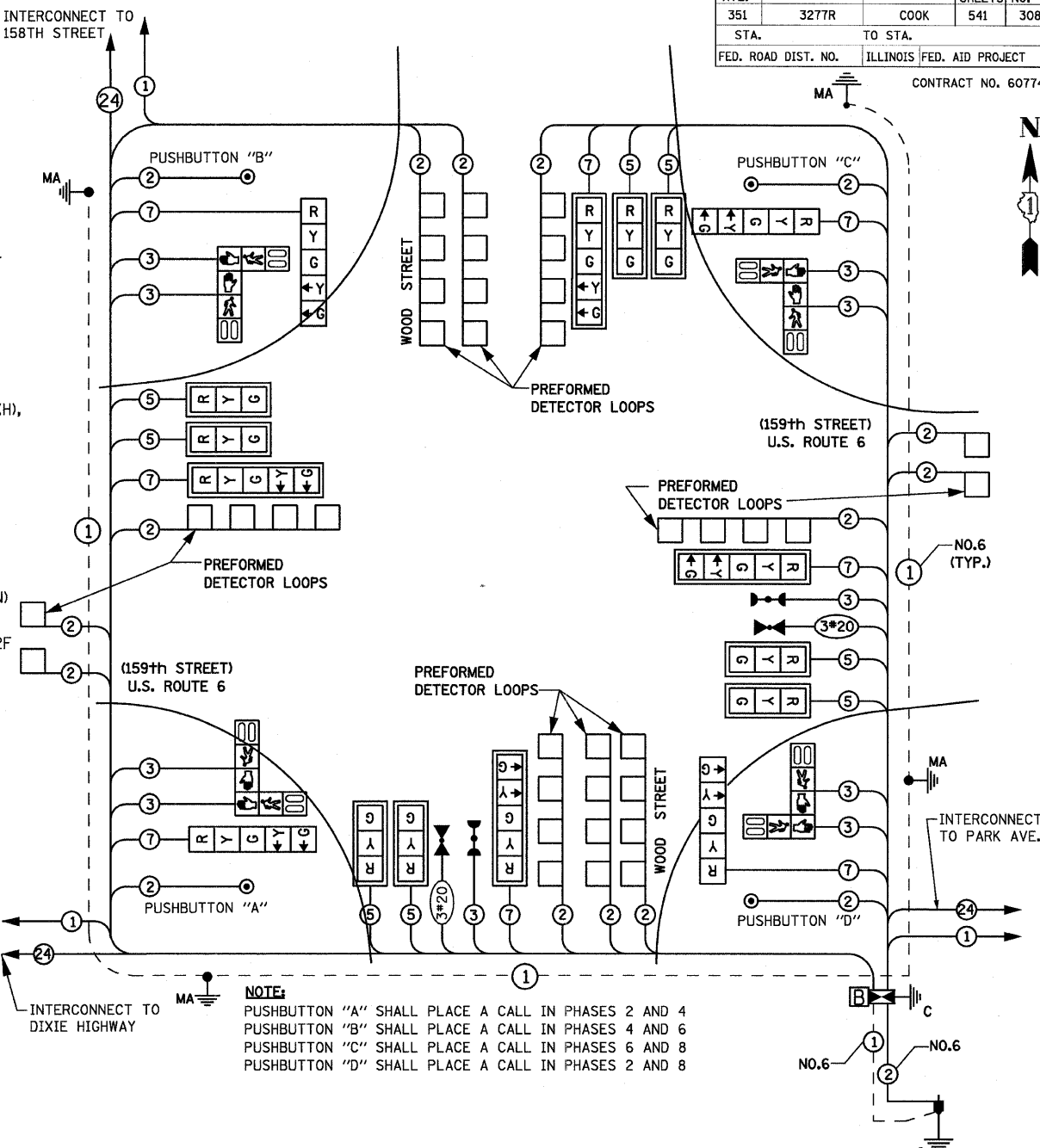

NOTE:
PUSHBUTTON "A" SHALL PLACE A CALL IN PHASES 2 AND 4
PUSHBUTTON "B" SHALL PLACE A CALL IN PHASES 4 AND 6
PUSHBUTTON "C" SHALL PLACE A CALL IN PHASES 6 AND 8
PUSHBUTTON "D" SHALL PLACE A CALL IN PHASES 2 AND 8

NOTE:
THE TRAFFIC SIGNAL CONTROLLER EQUIPMENT FOR THIS PROJECT SHALL BE "EAGLE" TO MATCH THE EXISTING ADJACENT SYSTEM.

REVISIONS	
NAME	DATE

ILLINOIS DEPARTMENT OF TRANSPORTATION
US RTE 6 FROM I-294 TO IL RTE 1
SCHEDULE OF QUANTITIES AND CABLE PLAN
US RTE 6 & WOOD STREET
SCALE: NONE DRAWN BY: DK
DATE: 01/28/09 CHECKED BY: JA

F.A. RTE.	SECTION	COUNTY	TOTAL SHEETS	SHEET NO.
351	3277R	COOK	541	309
STA. 2+350		TO STA. 2+450		
FED. ROAD DIST. NO.		ILLINOIS FED. AID PROJECT		







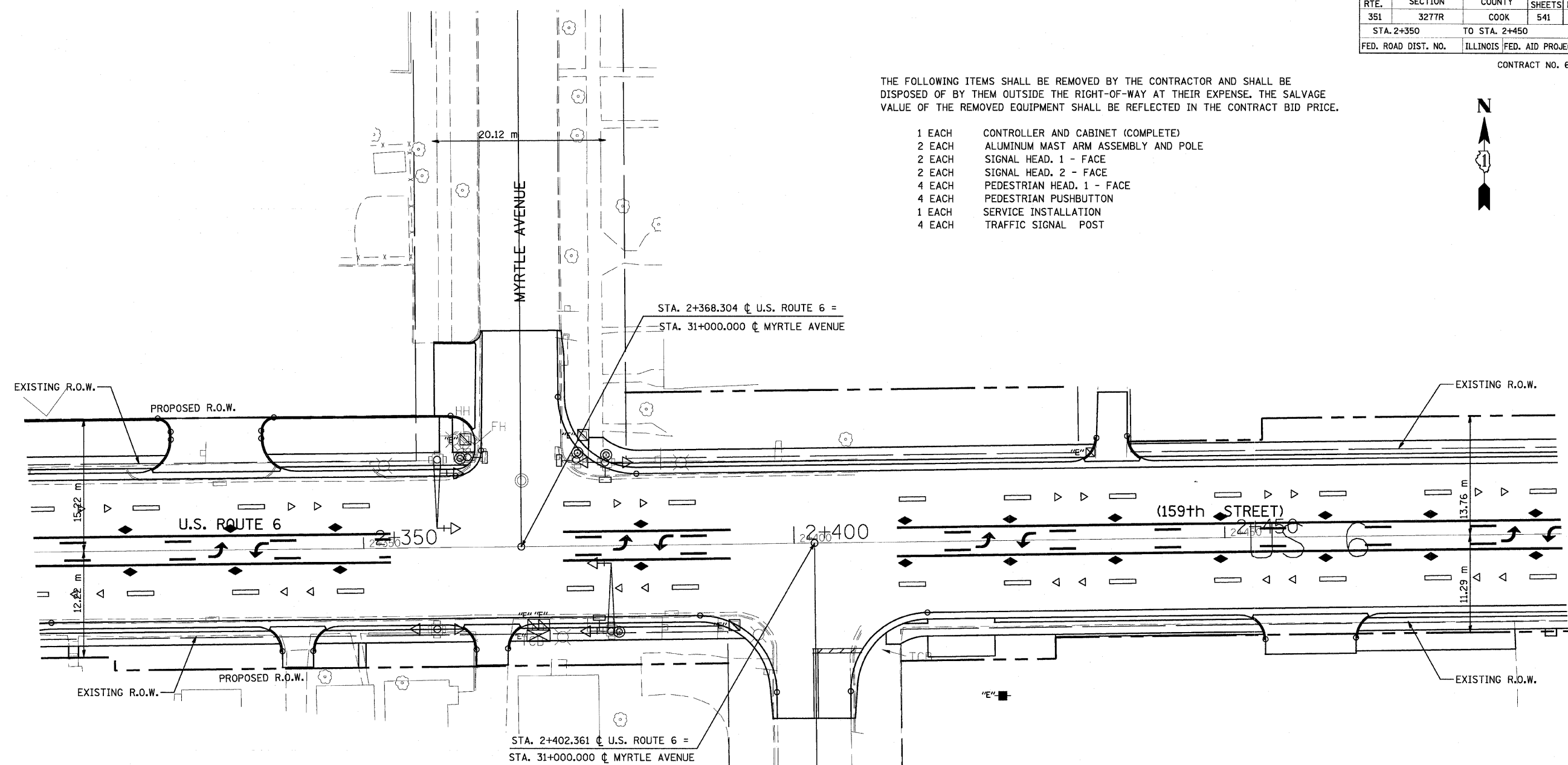





CONTRACT NO. 60774

THE FOLLOWING ITEMS SHALL BE REMOVED BY THE CONTRACTOR AND SHALL BE DISPOSED OF BY THEM OUTSIDE THE RIGHT-OF-WAY AT THEIR EXPENSE. THE SALVAGE VALUE OF THE REMOVED EQUIPMENT SHALL BE REFLECTED IN THE CONTRACT BID PRICE.

- 1 EACH CONTROLLER AND CABINET (COMPLETE)
- 2 EACH ALUMINUM MAST ARM ASSEMBLY AND POLE
- 2 EACH SIGNAL HEAD, 1 - FACE
- 2 EACH SIGNAL HEAD, 2 - FACE
- 4 EACH PEDESTRIAN HEAD, 1 - FACE
- 4 EACH PEDESTRIAN PUSHBUTTON
- 1 EACH SERVICE INSTALLATION
- 4 EACH TRAFFIC SIGNAL POST



EXISTING EQUIPMENT TO BE REMOVED LEGEND

- EXISTING SIGNAL HEAD TO BE REMOVED 
- EXISTING SERVICE INSTALLATION TO BE REMOVED 
- EXISTING CONTROLLER TO BE REMOVED 
- EXISTING HANDHOLE TO BE REMOVED 
- EXISTING PEDESTRIAN SIGNAL HEAD TO BE REMOVED 
- EXISTING PEDESTRIAN PUSH BUTTON TO BE REMOVED 
- EMERGENCY VEHICLE LIGHT DETECTOR TO BE REMOVED 
- CONFIRMATION BEACON TO BE REMOVED 
- EXISTING HEAVY-DUTY HANDHOLE TO BE REMOVED 
- EXISTING SIGNAL POST AND FOUNDATION TO BE REMOVED 
- EXISTING ALUMINUM MAST ARM POLE AND FOUNDATION TO BE REMOVED 
- EXISTING STEEL MAST ARM POLE AND FOUNDATION TO BE REMOVED 
- EXISTING STEEL COMBINATION MAST ARM POLE AND FOUNDATION TO BE REMOVED 

SCHEDULE OF QUANTITIES

PAY ITEM	UNIT	QTY.
REMOVE EXISTING TRAFFIC SIGNAL EQUIPMENT	EACH	1
REMOVE EXISTING HANDHOLE	EACH	6
REMOVE EXISTING CONCRETE FOUNDATION	EACH	7

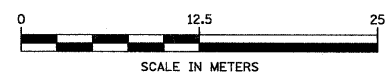

REVISIONS	
NAME	DATE

ILLINOIS DEPARTMENT OF TRANSPORTATION
 US RTE 6 FROM I-294 TO IL RTE 1
 REMOVE EXISTING TRAFFIC SIGNAL EQUIPMENT
 US RTE 6 & MYRTLE AVENUE

SCALE: 1:250
 DATE 01/28/09
 DRAWN BY DK
 CHECKED BY JA

F.A. RTE.	SECTION	COUNTY	TOTAL SHEETS	SHEET NO.
351	3277R	COOK	541	310
STA. 3+450		TO STA. 3+600		
FED. ROAD DIST. NO.		ILLINOIS	FED. AID PROJECT	

CONTRACT NO. 60774

THE FOLLOWING ITEMS SHALL BE REMOVED BY THE CONTRACTOR AND SHALL BE DISPOSED OF BY THEM OUTSIDE THE RIGHT-OF-WAY AT THEIR EXPENSE. THE SALVAGE VALUE OF THE REMOVED EQUIPMENT SHALL BE REFLECTED IN THE CONTRACT BID PRICE.

- 1 EACH CONTROLLER AND CABINET (COMPLETE)
- 2 EACH ALUMINUM MAST ARM ASSEMBLY AND POLE
- 4 EACH SIGNAL HEAD, 1 - FACE
- 4 EACH SIGNAL HEAD, 2 - FACE
- 2 EACH PEDESTRIAN HEAD, 1 - FACE
- 3 EACH PEDESTRIAN PUSHBUTTON
- 1 EACH SERVICE INSTALLATION
- 5 EACH TRAFFIC SIGNAL POST
- 1 EACH PEDESTRIAN HEAD, 2 - FACE

EXISTING EQUIPMENT TO BE REMOVED LEGEND

- EXISTING SIGNAL HEAD TO BE REMOVED
- EXISTING SERVICE INSTALLATION TO BE REMOVED
- EXISTING CONTROLLER TO BE REMOVED
- EXISTING HANDHOLE TO BE REMOVED
- EXISTING PEDESTRIAN SIGNAL HEAD TO BE REMOVED
- EXISTING PEDESTRIAN PUSH BUTTON TO BE REMOVED
- EMERGENCY VEHICLE LIGHT DETECTOR TO BE REMOVED
- CONFIRMATION BEACON TO BE REMOVED
- EXISTING HEAVY-DUTY HANDHOLE TO BE REMOVED
- EXISTING SIGNAL POST AND FOUNDATION TO BE REMOVED
- EXISTING ALUMINUM MAST ARM POLE AND FOUNDATION TO BE REMOVED
- EXISTING STEEL MAST ARM POLE AND FOUNDATION TO BE REMOVED
- EXISTING STEEL COMBINATION MAST ARM POLE AND FOUNDATION TO BE REMOVED

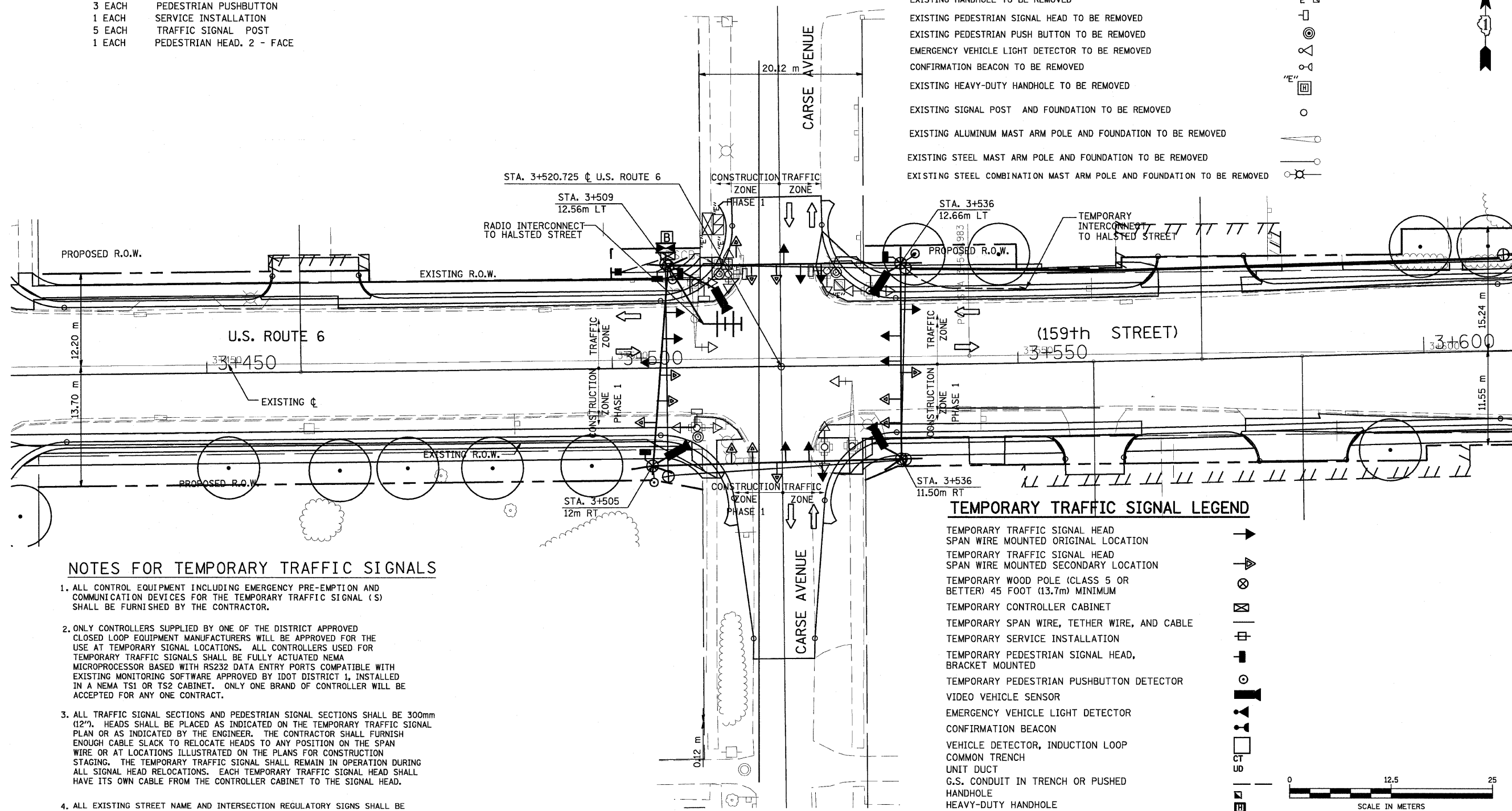
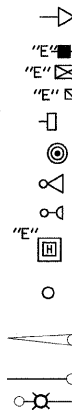

NOTES FOR TEMPORARY TRAFFIC SIGNALS

1. ALL CONTROL EQUIPMENT INCLUDING EMERGENCY PRE-EMPTION AND COMMUNICATION DEVICES FOR THE TEMPORARY TRAFFIC SIGNAL (S) SHALL BE FURNISHED BY THE CONTRACTOR.
2. ONLY CONTROLLERS SUPPLIED BY ONE OF THE DISTRICT APPROVED CLOSED LOOP EQUIPMENT MANUFACTURERS WILL BE APPROVED FOR THE USE AT TEMPORARY SIGNAL LOCATIONS. ALL CONTROLLERS USED FOR TEMPORARY TRAFFIC SIGNALS SHALL BE FULLY ACTUATED NEMA MICROPROCESSOR BASED WITH RS232 DATA ENTRY PORTS COMPATIBLE WITH EXISTING MONITORING SOFTWARE APPROVED BY IDOT DISTRICT 1, INSTALLED IN A NEMA TS1 OR TS2 CABINET. ONLY ONE BRAND OF CONTROLLER WILL BE ACCEPTED FOR ANY ONE CONTRACT.
3. ALL TRAFFIC SIGNAL SECTIONS AND PEDESTRIAN SIGNAL SECTIONS SHALL BE 300mm (12"). HEADS SHALL BE PLACED AS INDICATED ON THE TEMPORARY TRAFFIC SIGNAL PLAN OR AS INDICATED BY THE ENGINEER. THE CONTRACTOR SHALL FURNISH ENOUGH CABLE SLACK TO RELOCATE HEADS TO ANY POSITION ON THE SPAN WIRE OR AT LOCATIONS ILLUSTRATED ON THE PLANS FOR CONSTRUCTION STAGING. THE TEMPORARY TRAFFIC SIGNAL SHALL REMAIN IN OPERATION DURING ALL SIGNAL HEAD RELOCATIONS. EACH TEMPORARY TRAFFIC SIGNAL HEAD SHALL HAVE ITS OWN CABLE FROM THE CONTROLLER CABINET TO THE SIGNAL HEAD.
4. ALL EXISTING STREET NAME AND INTERSECTION REGULATORY SIGNS SHALL BE REMOVED FROM EXISTING POLES, RELOCATED AND SECURELY FASTENED TO THE SIGNAL SPAN WIRE OR WOOD POLE AS DIRECTED BY THE ENGINEER.
5. ANY TEMPORARY SIGNAL WITHIN AN EXISTING CLOSED LOOP TRAFFIC SIGNAL SYSTEM SHALL BE INTERCONNECTED TO THAT SYSTEM USING SIMILAR BRAND CONTROL EQUIPMENT.
6. THE TEMPORARY TRAFFIC SIGNAL SHALL HAVE THE SIGNAL HEAD DISPLAYS, SIGNAL HEAD PLACEMENTS AND CONTROLLER PHASING MATCH THE EXISTING TRAFFIC SIGNAL, AT THE TIME OF THE TURN ON, IF NO TRAFFIC STAGING IS IN PLACE OR WILL NOT BE STAGED ON THE DAY OF THE TURN ON.

TEMPORARY TRAFFIC SIGNAL LEGEND

- TEMPORARY TRAFFIC SIGNAL HEAD
- SPAN WIRE MOUNTED ORIGINAL LOCATION
- TEMPORARY TRAFFIC SIGNAL HEAD
- SPAN WIRE MOUNTED SECONDARY LOCATION
- TEMPORARY WOOD POLE (CLASS 5 OR BETTER) 45 FOOT (13.7m) MINIMUM
- TEMPORARY CONTROLLER CABINET
- TEMPORARY SPAN WIRE, TETHER WIRE, AND CABLE
- TEMPORARY SERVICE INSTALLATION
- TEMPORARY PEDESTRIAN SIGNAL HEAD, BRACKET MOUNTED
- TEMPORARY PEDESTRIAN PUSHBUTTON DETECTOR
- VIDEO VEHICLE SENSOR
- EMERGENCY VEHICLE LIGHT DETECTOR
- CONFIRMATION BEACON
- VEHICLE DETECTOR, INDUCTION LOOP
- COMMON TRENCH
- UNIT DUCT
- G.S. CONDUIT IN TRENCH OR PUSHED
- HANDHOLE
- HEAVY-DUTY HANDHOLE
- TEMPORARY BATTERY BACK-UP UPS SYSTEM

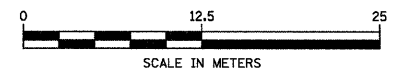

NOTE:
THE TRAFFIC SIGNAL CONTROLLER EQUIPMENT FOR THIS PROJECT SHALL BE "ECONOLITE" TO MATCH THE EXISTING ADJACENT SYSTEM.

REVISIONS	
NAME	DATE

ILLINOIS DEPARTMENT OF TRANSPORTATION
US RTE 6 FROM I-294 TO IL RTE 1
TEMPORARY TRAFFIC
SIGNAL INSTALLATION REMOVE
EXISTING TRAFFIC SIGNAL EQUIPMENT
US RTE 6 & CARSE AVENUE

SCALE: 1:250
DATE 01/28/09
DRAWN BY DK
CHECKED BY JA

TEMPORARY CABLE DIAGRAM LEGEND

- R TEMPORARY TRAFFIC SIGNAL SECTION OR PEDESTRIAN SIGNAL SECTION 12" (300 mm)
- TEMPORARY CONTROLLER CABINET
- TEMPORARY SERVICE INSTALLATION
- INDICATES NUMBER OF CONDUCTORS IN CABLE. ALL CONDUCTORS TO BE NUMBER 14 AWG WIRE UNLESS OTHERWISE NOTED.
- 5 EMERGENCY VEHICLE LIGHT DETECTOR
- 5 CONFIRMATION BEACON
- 5 PEDESTRIAN PUSHBUTTON DETECTOR
- VEHICLE DETECTOR, INDUCTION LOOP
- 12" (300mm) PEDESTRIAN SIGNAL SECTION
- VIDEO VEHICLE SENSOR
- B TEMPORARY BATTERY BACK-UP UPS SYSTEM

CONSTRUCTION NOTES

- THE EXISTING TRAFFIC RESPONSIVE CLOSED LOOP SYSTEM OPERATION SHALL BE MAINTAINED DURING CONSTRUCTION. THE CONTRACTOR SHALL CONTACT THE S.C.A.T. SYSTEMS ENGINEER, MR. GEORGE BROWN AT (847) 697-6700 AT LEAST 72 HOURS PRIOR TO THE START OF WORK TO REQUEST MODIFICATION OF THE EXISTING TRAFFIC RESPONSIVE PROGRAM. UPON COMPLETION AND ACCEPTANCE OF THE TRAFFIC SIGNAL MODIFICATIONS, THE CONTRACTOR SHALL CONTACT THE SIGNAL SYSTEM ENGINEER TO REQUEST RESTORATION OF THE ORIGINAL TRAFFIC RESPONSIVE PROGRAM.
- THE CONTRACTOR SHALL MAINTAIN THE EXISTING SIGNAL SYSTEM INTERCONNECT DURING TEMPORARY SIGNAL OPERATION. THE INSTALLATION OF THE TEMPORARY INTERCONNECT CABLE OR RADIO SHALL BE NON-DESTRUCTIVE. THE INSTALLATION AND MAINTENANCE OF THE TEMPORARY INTERCONNECT CABLE OR RADIO SHALL BE INCIDENTAL TO THE COST OF TEMPORARY TRAFFIC SIGNAL INSTALLATION.
- THE TRAFFIC SIGNAL SECTIONS SHALL BE DEACTIVATED AND BAGGED DURING STAGES 1 & 2 AND AS REQUIRED DURING CONSTRUCTION STAGING. THE SECTIONS SHALL BE UNBAGGED AT THE END OF STAGE 2
- THE PHASING SHALL BE DEACTIVATED DURING CONSTRUCTION STAGES 1 & 2 AND AS REQUIRED DURING CONSTRUCTION STAGING. THE LEFT TURN PHASING SHALL BE ACTIVATED AT THE END OF STAGE 2.
- LED SIGNAL HEADS SHALL BE USED FOR ALL TEMPORARY TRAFFIC SIGNALS.

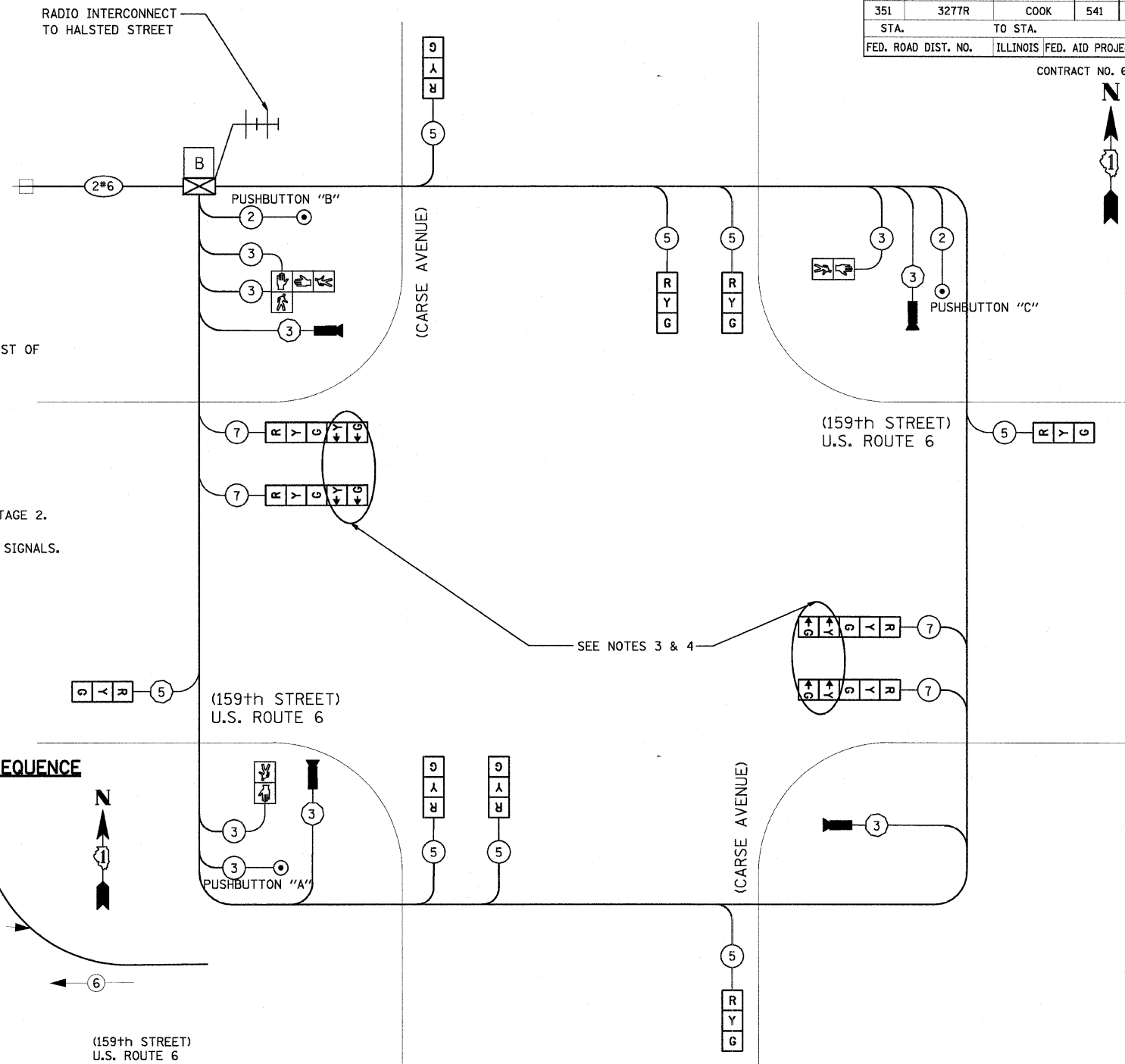

TEMPORARY CONTROLLER SEQUENCE

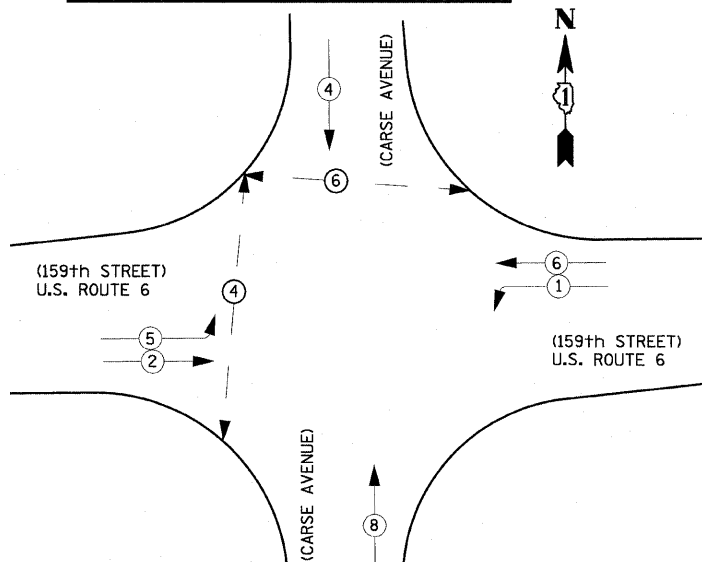

TEMPORARY PHASE DESIGNATION DIAGRAM AT END OF STAGE 2

TEMPORARY CONTROLLER SEQUENCE

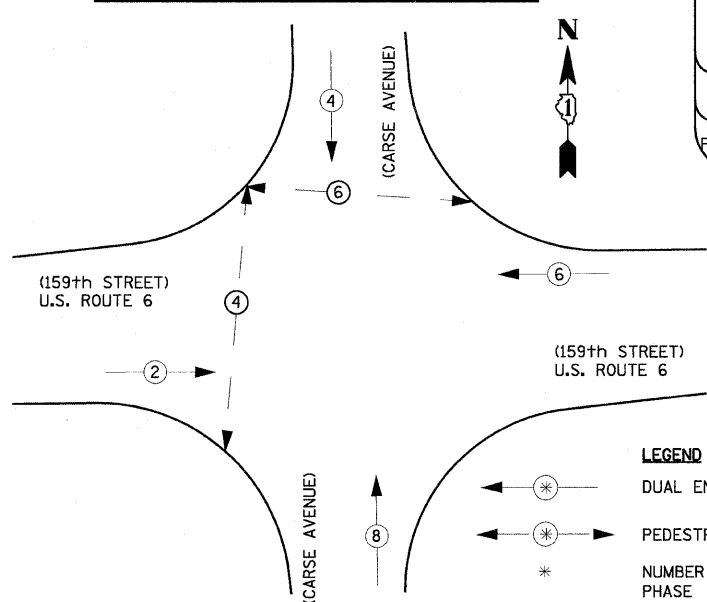

TEMPORARY PHASE DESIGNATION DIAGRAM STAGE 1

- LEGEND**
- * DUAL ENTRY PHASE
 - * PEDESTRIAN MOVEMENT
 - * NUMBER REFERS TO ASSOCIATED PHASE

NOTE:

PUSHBUTTON "A" SHALL PLACE A CALL IN PHASES 4 AND 6
 PUSHBUTTON "B" SHALL PLACE A CALL IN PHASES 4 AND 6
 PUSHBUTTON "C" SHALL PLACE A CALL IN PHASES 6

NOTE:

THE TRAFFIC SIGNAL CONTROLLER EQUIPMENT FOR THIS PROJECT SHALL BE "ECONOLITE" TO MATCH THE EXISTING ADJACENT SYSTEM.

I.D.O.T. TRAFFIC SIGNAL INSTALLATION ELECTRICAL SERVICE REQUIREMENTS					TOTAL WATTAGE
TYPE	NO. LAMPS	WATTAGE (INCAND.)	WATTAGE (LED)	% OPERATION	
SIGNAL (RED)	12	135	17	0.50	102.00
(YELLOW)	12	135	25	0.25	75.00
(GREEN)	12	135	15	0.25	45.00
ARROW	8	135	12	0.10	9.60
PED. SIGNAL	4	90	25	1.00	100.00
CONTROLLER	1	100	100	1.00	100.00
ILLUM. SIGN		84		0.05	
FLASHER				0.50	
ENERGY COSTS TO:					TOTAL = 431.6

ILLINOIS DEPARTMENT OF TRANSPORTATION
 201 WEST CENTER COURT
 SCHUMBURG, ILLINOIS 60196-1096
 CONTACT: MIKE LYNCH
 PHONE: (847) 816-5331
 COMPANY: COM. EDISON

FOUNDATION (DEPTH)	FT. (m)	CABLE SLACK	FT. (m)	VERTICAL	FT. (m)
TYPE A - POST	4 (1.2)	HANDHOLE	6.5 (2.0)	ALL FOUNDATIONS	3.5 (1.0)
D - CONTROLLER	4 (1.2)	DOUBLE HANDHOLE	13 (4.0)	MAST ARM (L) POLE	20'-H-2=
E - M. ARM POLE		SIGNAL POST	2 (1.0)	(6m+L-0.6m)=	
	30" (750mm)	CONTROLLER CAB.	1 (0.5)	BRACKET MOUNTED	13 (4.0)
	36" (900mm)	FIBER OPTIC	13 (4.0)	PED. PUSHBUTTON	4 (1.2)
	36" (900mm)	ELECTRIC SERVICE	1 (0.5)	ELECTRIC SERVICE	13.5 (4.1)
	36" (900mm)	GROUND CABLE	1 (0.5)	SERVICE TO GROUND	13.5 (4.1)
				POST MOUNTED	6 (1.8)

REVISIONS	
NAME	DATE

ILLINOIS DEPARTMENT OF TRANSPORTATION
 US RTE 6 FROM I-294 TO IL RTE 1

**TEMPORARY CABLE PLAN
 US RTE 6 & CARSE AVENUE**

SCALE: NONE
 DATE 01/28/09
 DRAWN BY DK
 CHECKED BY JA

F.A. RTE.	SECTION	COUNTY	TOTAL SHEETS	SHEET NO.
351	3277R	COOK	541	312
STA. 3+450		TO STA. 3+600		
FED. ROAD DIST. NO.		ILLINOIS FED. AID PROJECT		

CONTRACT NO. 60774

TRAFFIC SIGNAL EQUIPMENT STATION & OFFSET TABLE

ITEM	STATION	OFFSET
M1	3+508.72	12.11 R
M2	3+511.45	14.18 L
M3	3+530.76	13.61 L
M4	3+529.44	13.90 R
CONTROLLER	3+512.80	18.33 L

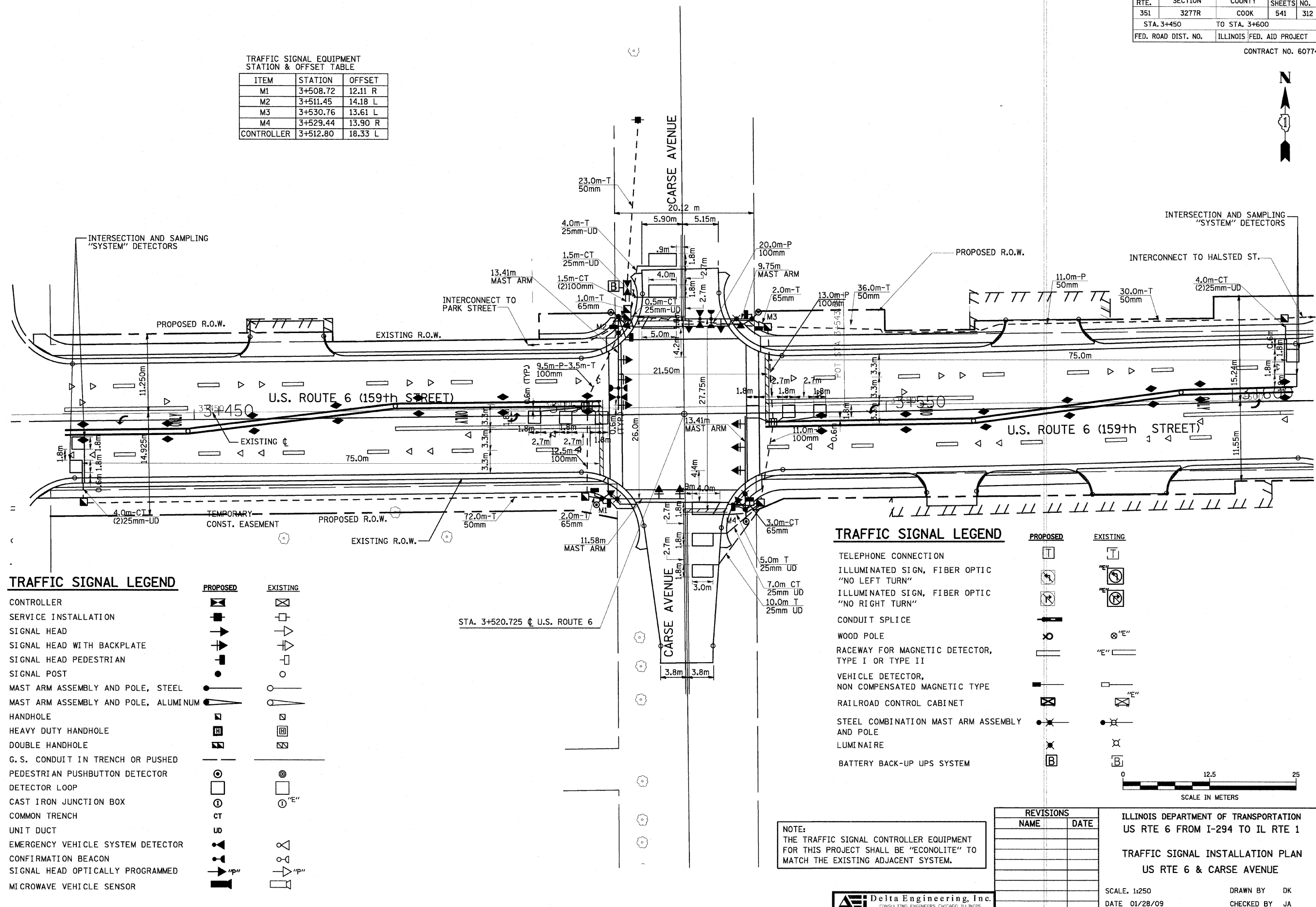

TRAFFIC SIGNAL LEGEND

	PROPOSED	EXISTING
CONTROLLER	[Symbol]	[Symbol]
SERVICE INSTALLATION	[Symbol]	[Symbol]
SIGNAL HEAD	[Symbol]	[Symbol]
SIGNAL HEAD WITH BACKPLATE	[Symbol]	[Symbol]
SIGNAL HEAD PEDESTRIAN	[Symbol]	[Symbol]
SIGNAL POST	[Symbol]	[Symbol]
MAST ARM ASSEMBLY AND POLE, STEEL	[Symbol]	[Symbol]
MAST ARM ASSEMBLY AND POLE, ALUMINUM	[Symbol]	[Symbol]
HANDHOLE	[Symbol]	[Symbol]
HEAVY DUTY HANDHOLE	[Symbol]	[Symbol]
DOUBLE HANDHOLE	[Symbol]	[Symbol]
G.S. CONDUIT IN TRENCH OR PUSHED	[Symbol]	[Symbol]
PEDESTRIAN PUSHBUTTON DETECTOR	[Symbol]	[Symbol]
DETECTOR LOOP	[Symbol]	[Symbol]
CAST IRON JUNCTION BOX	[Symbol]	[Symbol]
COMMON TRENCH	[Symbol]	[Symbol]
UNIT DUCT	[Symbol]	[Symbol]
EMERGENCY VEHICLE SYSTEM DETECTOR	[Symbol]	[Symbol]
CONFIRMATION BEACON	[Symbol]	[Symbol]
SIGNAL HEAD OPTICALLY PROGRAMMED	[Symbol]	[Symbol]
MICROWAVE VEHICLE SENSOR	[Symbol]	[Symbol]

TRAFFIC SIGNAL LEGEND

	PROPOSED	EXISTING
TELEPHONE CONNECTION	[Symbol]	[Symbol]
ILLUMINATED SIGN, FIBER OPTIC "NO LEFT TURN"	[Symbol]	[Symbol]
ILLUMINATED SIGN, FIBER OPTIC "NO RIGHT TURN"	[Symbol]	[Symbol]
CONDUIT SPLICE	[Symbol]	[Symbol]
WOOD POLE	[Symbol]	[Symbol]
RACEWAY FOR MAGNETIC DETECTOR, TYPE I OR TYPE II	[Symbol]	[Symbol]
VEHICLE DETECTOR, NON COMPENSATED MAGNETIC TYPE	[Symbol]	[Symbol]
RAILROAD CONTROL CABINET	[Symbol]	[Symbol]
STEEL COMBINATION MAST ARM ASSEMBLY AND POLE	[Symbol]	[Symbol]
LUMINAIRE	[Symbol]	[Symbol]
BATTERY BACK-UP UPS SYSTEM	[Symbol]	[Symbol]

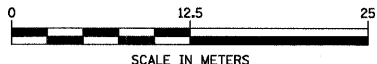

NOTE:
THE TRAFFIC SIGNAL CONTROLLER EQUIPMENT FOR THIS PROJECT SHALL BE "ECONOLITE" TO MATCH THE EXISTING ADJACENT SYSTEM.

REVISIONS	
NAME	DATE

ILLINOIS DEPARTMENT OF TRANSPORTATION
US RTE 6 FROM I-294 TO IL RTE 1

TRAFFIC SIGNAL INSTALLATION PLAN
US RTE 6 & CARSE AVENUE

SCALE: 1:250
DATE 01/28/09

DRAWN BY DK
CHECKED BY JA

SCHEDULE OF QUANTITIES

PAY ITEM	UNIT	QTY.
HANDHOLE	EACH	5
HEAVY-DUTY HANDHOLE	EACH	2
DOUBLE HANDHOLE	EACH	1
FULL-ACTUATED CONTROLLER AND TYPE IV CABINET	EACH	1
TRANSCIVER-FIBER OPTIC	EACH	1
TRAFFIC SIGNAL BACKPLATE	EACH	10
INDUCTIVE LOOP DETECTOR	EACH	8
*LIGHT DETECTOR	EACH	2
*LIGHT DETECTOR AMPLIFIER	EACH	1
PEDESTRIAN PUSH-BUTTON	EACH	4
TEMPORARY TRAFFIC SIGNAL INSTALLATION	EACH	1
REMOVE EXISTING TRAFFIC SIGNAL EQUIPMENT	EACH	1
REMOVE EXISTING HANDHOLE	EACH	4
REMOVE EXISTING CONCRETE FOUNDATION	EACH	8
SIGN PANEL - TYPE 1	SQ M	1.4
SIGN PANEL - TYPE 2	SQ M	2.1
CONDUIT IN TRENCH, 50MM DIA., GALVANIZED STEEL	METER	163
CONDUIT IN TRENCH, 65MM DIA., GALVANIZED STEEL	METER	11
CONDUIT IN TRENCH, 100MM DIA., GALVANIZED STEEL	METER	3
CONDUIT PUSHED, 50MM DIA., GALVANIZED STEEL	METER	11
CONDUIT PUSHED, 100MM DIA., GALVANIZED STEEL	METER	74
TRENCH AND BACKFILL FOR ELECTRICAL WORK	METER	177
ELECTRIC CABLE IN CONDUIT, SIGNAL NO. 14 2C	METER	157
ELECTRIC CABLE IN CONDUIT, SIGNAL NO. 14 3C	METER	337
ELECTRIC CABLE IN CONDUIT, SIGNAL NO. 14 5C	METER	507
ELECTRIC CABLE IN CONDUIT, SIGNAL NO. 14 7C	METER	198
ELECTRIC CABLE IN CONDUIT, LEAD-IN, NO 4 1 PAIR	METER	708
ELECTRIC CABLE IN CONDUIT, SERVICE, NO. 6 2C	METER	21
STEEL COMBINATION MAST ARM ASSEMBLY AND POLE 9.75 METER	EACH	3
STEEL COMBINATION MAST ARM ASSEMBLY AND POLE 11.58 METER	EACH	1
CONCRETE FOUNDATION, TYPE D	METER	1.2
CONCRETE FOUNDATION, TYPE E 750 MM DIAMETER	METER	18.4
ELECTRIC CABLE IN CONDUIT, GROUNDING, NO. 6 1C	METER	159
ELECTRIC CABLE IN CONDUIT, NO. 20 3/C, TWISTED, SHIELDED	METER	77
PREFORMED DETECTOR LOOP	METER	113
SERVICE INSTALLATION, POLE MOUNT	EACH	1
SIGNAL HEAD, LED, 1-FACE, 3-SECTION, MAST ARM MOUNTED	EACH	8
SIGNAL HEAD, LED, 1-FACE, 3-SECTION, BRACKET MOUNTED	EACH	2
SIGNAL HEAD, LED, 1-FACE, 5-SECTION, BRACKET MOUNTED	EACH	2
SIGNAL HEAD, LED, 1-FACE, 5-SECTION, MAST ARM MOUNTED	EACH	2
PEDESTRIAN SIGNAL HEAD, LED, 2-FACE BRACKET MOUNTED WITH COUNTDOWN TIMER	EACH	4
TEMPORARY TRAFFIC SIGNAL TIMING	EACH	1
UNINTERRUPTABLE POWER SUPPLY	EACH	1

* 100% cost to City of Harvey

CABLE PLAN LEGEND

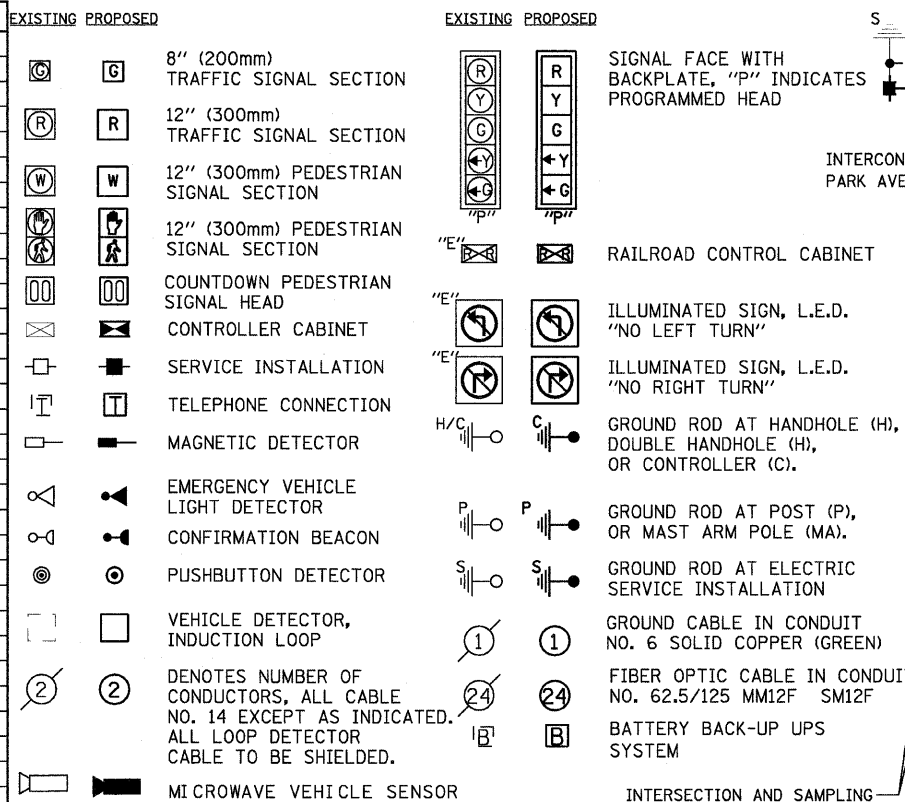

CONTROLLER SEQUENCE

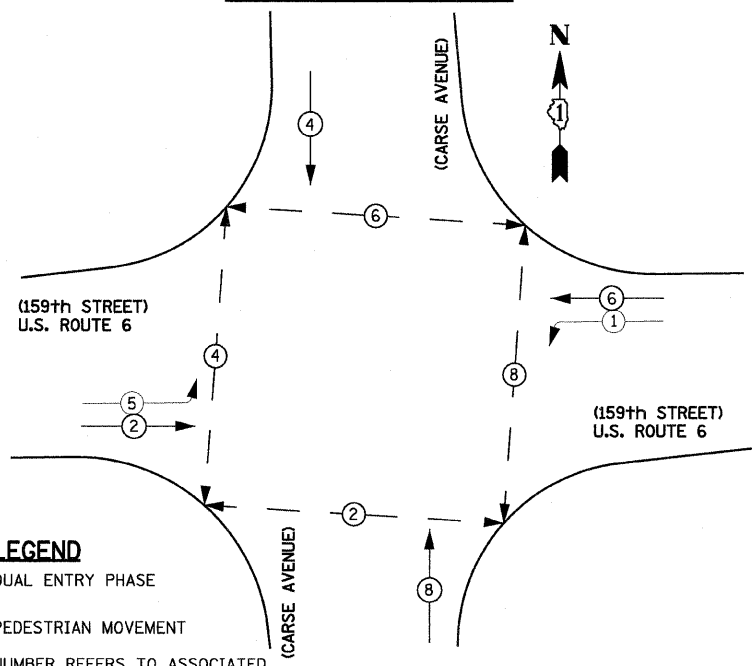

LEGEND

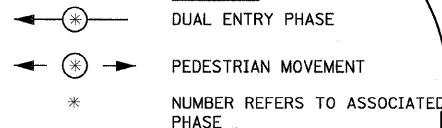

PHASE DESIGNATION DIAGRAM

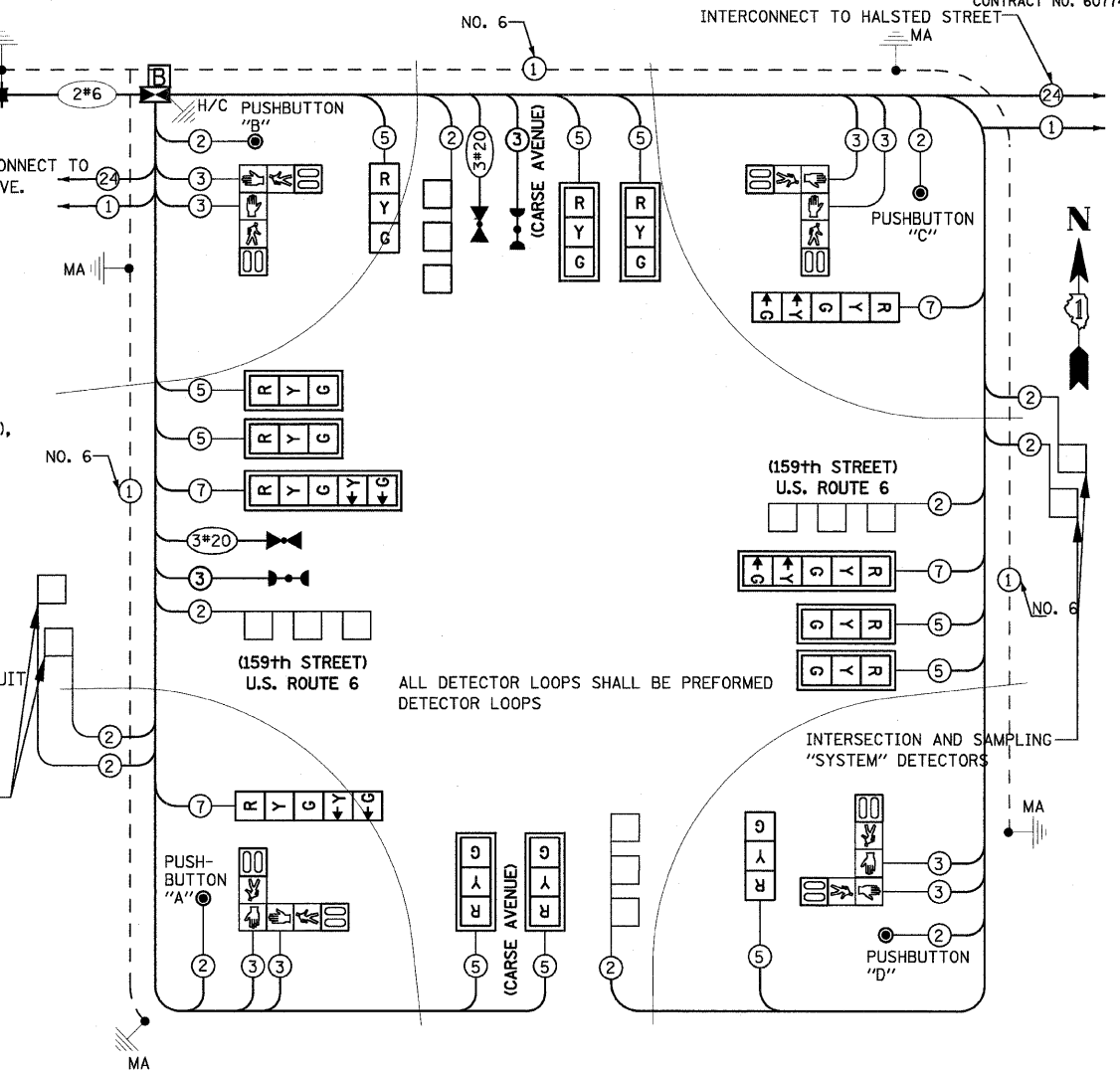

VEHICLE EMERGENCY PREEMPTOR	3	4
MOVEMENT	← →	↑ ↓

NOTE:
 PUSHBUTTON "A" SHALL PLACE A CALL IN PHASES 2 AND 4
 PUSHBUTTON "B" SHALL PLACE A CALL IN PHASES 4 AND 6
 PUSHBUTTON "C" SHALL PLACE A CALL IN PHASES 6 AND 8
 PUSHBUTTON "D" SHALL PLACE A CALL IN PHASES 2 AND 8

TYPE	NO. LAMPS*	WATTAGE INCAND. LED	% OPERATION	TOTAL WATTAGE
SIGNAL (RED)	14	135 17	0.50	119.0
(YELLOW)	14	135 25	0.25	87.5
(GREEN)	14	135 15	0.25	52.5
ARROW	8	135 12	0.10	9.6
PED. SIGNAL	8	90 25	1.00	200.0
CONTROLLER	1	100 100	1.00	100.0
ILLUM. SIGN		84	0.05	

ENERGY COSTS TO: TOTAL = 568.60
 ILLINOIS DEPARTMENT OF TRANSPORTATION
 201 WEST CENTER COURT
 SCHAMBURG, ILLINOIS 60196-1096
 ENERGY SUPPLY CONTACT: MIKE LYNCH
 PHONE: (847) 816-5331
 COMPANY: COM. EDISON

FOUNDATION (DEPTH)	FT. (m)	CABLE SLACK	FT. (m)	VERTICAL	FT. (m)
TYPE A - POST	4 (1.2)	HANDHOLE	6.5 (2.0)	ALL FOUNDATIONS	3.5 (1.0)
D - CONTROLLER	4 (1.2)	DOUBLE HANDHOLE	13 (4.0)	MAST ARM (L) POLE	20'-H-2= (6m+H-0.6m)=
E - M. ARM POLE		SIGNAL POST	2 (0.6)	BRACKET MOUNTED	13 (4.0)
	30" (750mm)	CONTROLLER CAB.	1 (0.3)	PEDE. PUSHBUTTON	4 (1.2)
	36" (900mm)	FIBER OPTIC	13 (4.0)	ELECTRIC SERVICE	13.5 (4.1)
	36" (900mm)	ELECTRIC SERVICE	1 (0.3)	SERVICE TO GROUND	13.5 (4.1)
	36" (900mm)	GROUND CABLE	1 (0.3)	POST MOUNTED	6 (1.8)

NOTE:
 THE TRAFFIC SIGNAL CONTROLLER EQUIPMENT FOR THIS PROJECT SHALL BE "ECONOLITE" TO MATCH THE EXISTING ADJACENT SYSTEM.

Delta Engineering, Inc.
 CONSULTING ENGINEERS, CHICAGO, ILLINOIS.

NAME	DATE

ILLINOIS DEPARTMENT OF TRANSPORTATION
 US RTE 6 FROM I-294 TO IL RTE 1
SCHEDULE OF QUANTITIES AND CABLE PLAN
 US RTE 6 & CARSE AVENUE
 SCALE: NONE DRAWN BY: DK
 DATE: 01/28/09 CHECKED BY: JA

CONTRACT NO. 60774

THE FOLLOWING ITEMS SHALL BE REMOVED BY THE CONTRACTOR AND SHALL BE DISPOSED OF BY THEM OUTSIDE THE RIGHT-OF-WAY AT THEIR EXPENSE. THE SALVAGE VALUE OF THE REMOVED EQUIPMENT SHALL BE REFLECTED IN THE CONTRACT BID PRICE.

- 1 EACH CONTROLLER AND CABINET (COMPLETE)
- 4 EACH ALUMINUM MAST ARM ASSEMBLY AND POLE
- 10 EACH SIGNAL HEAD, 1 - FACE
- 3 EACH SIGNAL HEAD, 2 - FACE
- 8 EACH PEDESTRIAN HEAD, 1 - FACE
- 4 EACH PEDESTRIAN PUSHBUTTON
- 1 EACH SERVICE INSTALLATION
- 1 EACH TRAFFIC SIGNAL POST

EXISTING EQUIPMENT TO BE REMOVED LEGEND

- EXISTING SIGNAL HEAD TO BE REMOVED
- EXISTING SERVICE INSTALLATION TO BE REMOVED
- EXISTING CONTROLLER TO BE REMOVED
- EXISTING HANDHOLE TO BE REMOVED
- EXISTING PEDESTRIAN SIGNAL HEAD TO BE REMOVED
- EXISTING PEDESTRIAN PUSH BUTTON TO BE REMOVED
- EMERGENCY VEHICLE LIGHT DETECTOR TO BE REMOVED
- CONFIRMATION BEACON TO BE REMOVED
- EXISTING HEAVY-DUTY HANDHOLE TO BE REMOVED
- EXISTING SIGNAL POST AND FOUNDATION TO BE REMOVED
- EXISTING ALUMINUM MAST ARM POLE AND FOUNDATION TO BE REMOVED
- EXISTING STEEL MAST ARM POLE AND FOUNDATION TO BE REMOVED
- EXISTING STEEL COMBINATION MAST ARM POLE AND FOUNDATION TO BE REMOVED

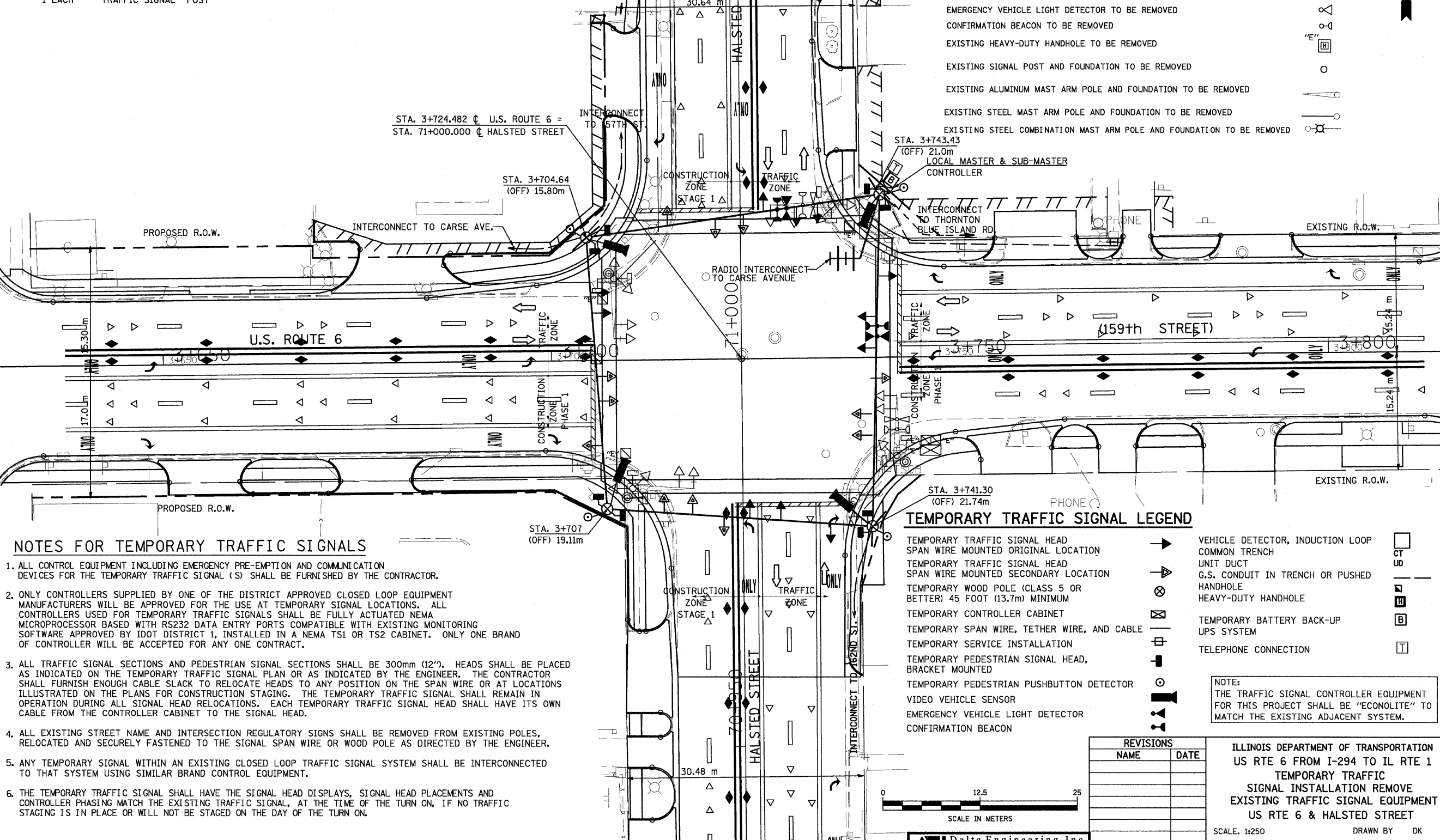
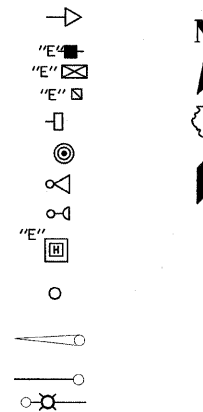

NOTES FOR TEMPORARY TRAFFIC SIGNALS

- ALL CONTROL EQUIPMENT INCLUDING EMERGENCY PRE-EMPTION AND COMMUNICATION DEVICES FOR THE TEMPORARY TRAFFIC SIGNAL (S) SHALL BE FURNISHED BY THE CONTRACTOR.
- ONLY CONTROLLERS SUPPLIED BY ONE OF THE DISTRICT APPROVED CLOSED LOOP EQUIPMENT MANUFACTURERS WILL BE APPROVED FOR THE USE AT TEMPORARY SIGNAL LOCATIONS. ALL CONTROLLERS USED FOR TEMPORARY TRAFFIC SIGNALS SHALL BE FULLY ACTUATED NEMA MICROPROCESSOR BASED WITH RS232 DATA ENTRY PORTS COMPATIBLE WITH EXISTING MONITORING SOFTWARE APPROVED BY IDOT DISTRICT 1, INSTALLED IN A NEMA TS1 OR TS2 CABINET. ONLY ONE BRAND OF CONTROLLER WILL BE ACCEPTED FOR ANY ONE CONTRACT.
- ALL TRAFFIC SIGNAL SECTIONS AND PEDESTRIAN SIGNAL SECTIONS SHALL BE 300mm (12"). HEADS SHALL BE PLACED AS INDICATED ON THE TEMPORARY TRAFFIC SIGNAL PLAN OR AS INDICATED BY THE ENGINEER. THE CONTRACTOR SHALL FURNISH ENOUGH CABLE SLACK TO RELOCATE HEADS TO ANY POSITION ON THE SPAN WIRE OR AT LOCATIONS ILLUSTRATED ON THE PLANS FOR CONSTRUCTION STAGING. THE TEMPORARY TRAFFIC SIGNAL SHALL REMAIN IN OPERATION DURING ALL SIGNAL HEAD RELOCATIONS. EACH TEMPORARY TRAFFIC SIGNAL HEAD SHALL HAVE ITS OWN CABLE FROM THE CONTROLLER CABINET TO THE SIGNAL HEAD.
- ALL EXISTING STREET NAME AND INTERSECTION REGULATORY SIGNS SHALL BE REMOVED FROM EXISTING POLES, RELOCATED AND SECURELY FASTENED TO THE SIGNAL SPAN WIRE OR WOOD POLE AS DIRECTED BY THE ENGINEER.
- ANY TEMPORARY SIGNAL WITHIN AN EXISTING CLOSED LOOP TRAFFIC SIGNAL SYSTEM SHALL BE INTERCONNECTED TO THAT SYSTEM USING SIMILAR BRAND CONTROL EQUIPMENT.
- THE TEMPORARY TRAFFIC SIGNAL SHALL HAVE THE SIGNAL HEAD DISPLAYS, SIGNAL HEAD PLACEMENTS AND CONTROLLER PHASING MATCH THE EXISTING TRAFFIC SIGNAL, AT THE TIME OF THE TURN ON, IF NO TRAFFIC STAGING IS IN PLACE OR WILL NOT BE STAGED ON THE DAY OF THE TURN ON.

TEMPORARY TRAFFIC SIGNAL LEGEND

- TEMPORARY TRAFFIC SIGNAL HEAD SPAN WIRE MOUNTED ORIGINAL LOCATION
- TEMPORARY TRAFFIC SIGNAL HEAD SPAN WIRE MOUNTED SECONDARY LOCATION
- TEMPORARY WOOD POLE (CLASS 5 OR BETTER) 45 FOOT (13.7m) MINIMUM
- TEMPORARY CONTROLLER CABINET
- TEMPORARY SPAN WIRE, TETHER WIRE, AND CABLE
- TEMPORARY SERVICE INSTALLATION
- TEMPORARY PEDESTRIAN SIGNAL HEAD, BRACKET MOUNTED
- TEMPORARY PEDESTRIAN PUSHBUTTON DETECTOR
- VIDEO VEHICLE SENSOR
- EMERGENCY VEHICLE LIGHT DETECTOR
- CONFIRMATION BEACON
- VEHICLE DETECTOR, INDUCTION LOOP
- COMMON TRENCH
- UNIT DUCT
- G.S. CONDUIT IN TRENCH OR PUSHED
- HANDHOLE
- HEAVY-DUTY HANDHOLE
- TEMPORARY BATTERY BACK-UP UPS SYSTEM
- TELEPHONE CONNECTION

NOTE: THE TRAFFIC SIGNAL CONTROLLER EQUIPMENT FOR THIS PROJECT SHALL BE "ECONOLITE" TO MATCH THE EXISTING ADJACENT SYSTEM.

REVISIONS	
NAME	DATE

ILLINOIS DEPARTMENT OF TRANSPORTATION
 US RTE 6 FROM I-294 TO IL RTE 1
 TEMPORARY TRAFFIC
 SIGNAL INSTALLATION REMOVE
 EXISTING TRAFFIC SIGNAL EQUIPMENT
 US RTE 6 & HALSTED STREET

SCALE: 1:250
 DATE 01/28/09
 DRAWN BY DK
 CHECKED BY JA

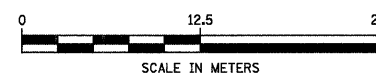

TEMPORARY CABLE DIAGRAM LEGEND

- R TEMPORARY TRAFFIC SIGNAL SECTION OR PEDESTRIAN SIGNAL SECTION 12" (300 mm)
- X TEMPORARY CONTROLLER CABINET
- T TEMPORARY SERVICE INSTALLATION
- 5 INDICATES NUMBER OF CONDUCTORS IN CABLE. ALL CONDUCTORS TO BE NUMBER 14 AWG WIRE UNLESS OTHERWISE NOTED.
- EMERGENCY VEHICLE LIGHT DETECTOR
- CONFIRMATION BEACON
- PEDESTRIAN PUSHBUTTON DETECTOR
- VEHICLE DETECTOR, INDUCTION LOOP
- 12" (300mm) PEDESTRIAN SIGNAL SECTION
- VIDEO VEHICLE SENSOR
- T TELEPHONE CONNECTION
- B TEMPORARY BATTERY BACK-UP UPS SYSTEM

CONSTRUCTION NOTES

- THE EXISTING TRAFFIC RESPONSIVE CLOSED LOOP SYSTEM OPERATION SHALL BE MAINTAINED DURING CONSTRUCTION. THE CONTRACTOR SHALL CONTACT THE S.C.A.T. SYSTEMS ENGINEER, MR. GEORGE BROWN AT (847) 697-6700 AT LEAST 72 HOURS PRIOR TO THE START OF WORK TO REQUEST MODIFICATION OF THE EXISTING TRAFFIC RESPONSIVE PROGRAM. UPON COMPLETION AND ACCEPTANCE OF THE TRAFFIC SIGNAL MODIFICATIONS, THE CONTRACTOR SHALL CONTACT THE SIGNAL SYSTEM ENGINEER TO REQUEST RESTORATION OF THE ORIGINAL TRAFFIC RESPONSIVE PROGRAM.
- THE CONTRACTOR SHALL MAINTAIN THE EXISTING SIGNAL SYSTEM INTERCONNECT DURING TEMPORARY SIGNAL OPERATION. THE INSTALLATION OF THE TEMPORARY INTERCONNECT CABLE OR RADIO SHALL BE NON-DESTRUCTIVE. THE INSTALLATION AND MAINTENANCE OF THE TEMPORARY INTERCONNECT CABLE OR RADIO SHALL BE INCIDENTAL TO THE COST OF TEMPORARY TRAFFIC SIGNAL INSTALLATION.
- THE PHASING SHALL BE DEACTIVATED AS REQUIRED DURING CONSTRUCTION STAGING.
- THE EMERGENCY VEHICLE PREEMPTION SEQUENCE SHALL BE MODIFIED AS REQUIRED DURING CONSTRUCTION STAGING.
- LED SIGNAL HEADS SHALL BE USED FOR ALL TEMPORARY TRAFFIC SIGNALS.

TEMPORARY CONTROLLER SEQUENCE

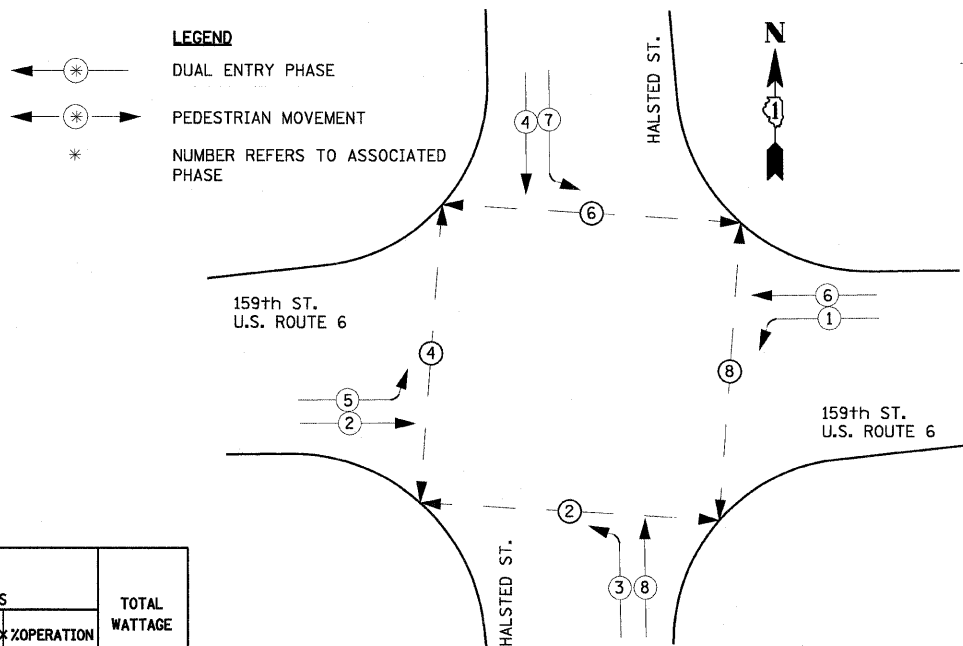

TEMPORARY PHASE DESIGNATION DIAGRAM

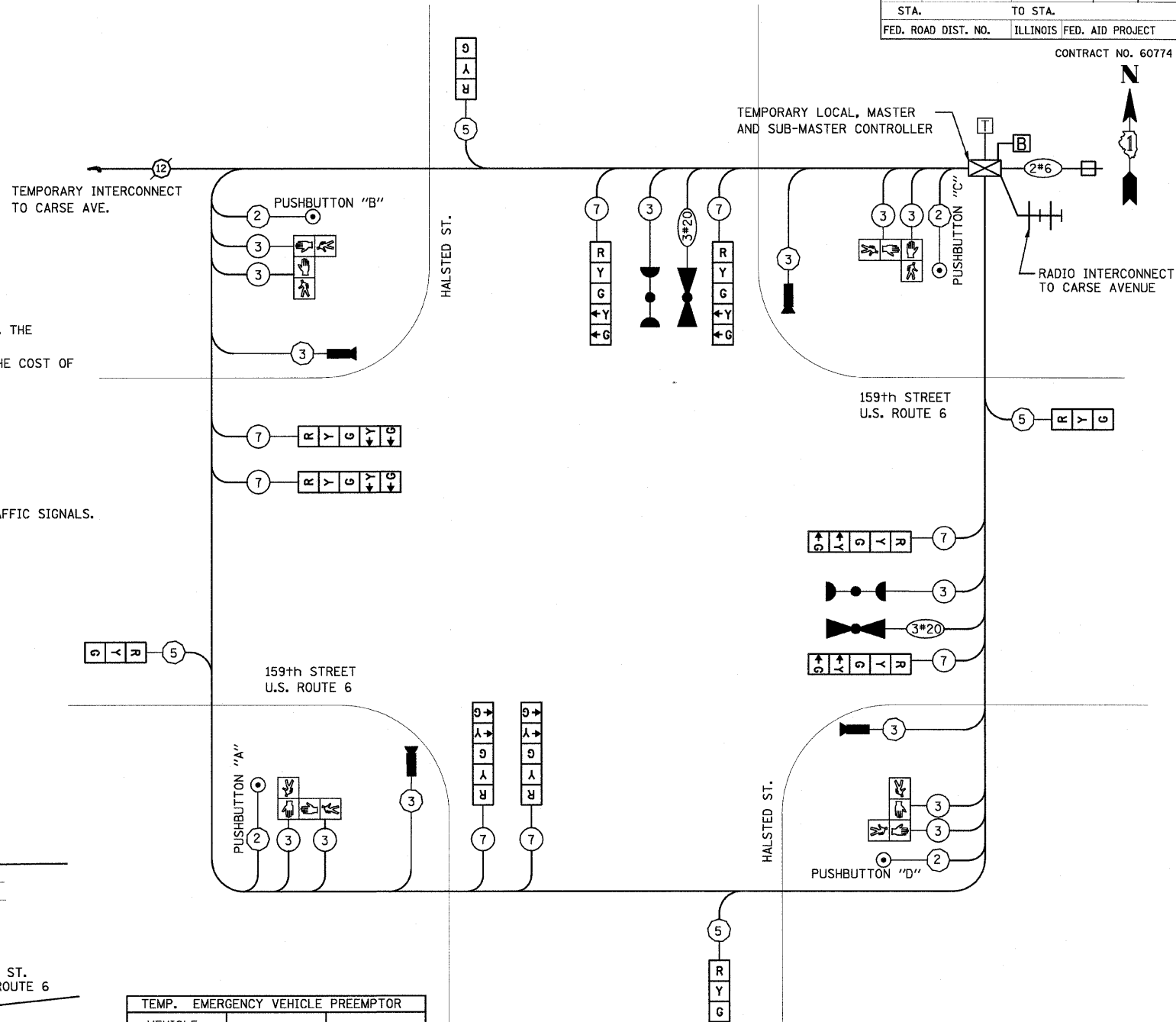

TEMP. EMERGENCY VEHICLE PREEMPTOR	
VEHICLE EMERGENCY PREEMPTOR	3 4
MOVEMENT	

NOTE:
 PUSHBUTTON "A" SHALL PLACE A CALL IN PHASES 2 AND 4
 PUSHBUTTON "B" SHALL PLACE A CALL IN PHASES 4 AND 6
 PUSHBUTTON "C" SHALL PLACE A CALL IN PHASES 6 AND 8
 PUSHBUTTON "D" SHALL PLACE A CALL IN PHASES 2 AND 8

NOTE:
 THE TRAFFIC SIGNAL CONTROLLER EQUIPMENT FOR THIS PROJECT SHALL BE "ECONOLITE" TO MATCH THE EXISTING ADJACENT SYSTEM.

I.D.O.T. TRAFFIC SIGNAL INSTALLATION ELECTRICAL SERVICE REQUIREMENTS					TOTAL WATTAGE
TYPE	NO. LAMPS*	WATTAGE (INCAND.)	WATTAGE LED	% OPERATION	
SIGNAL (RED)	12	135	17	0.50	102.00
(YELLOW)	12	135	25	0.25	75.00
(GREEN)	12	135	15	0.25	45.00
ARROW	16	135	12	0.10	19.20
PED. SIGNAL	8	90	25	1.00	200.00
CONTROLLER	1	100	100	1.00	100.00
ILLUM. SIGN		84		0.05	
FLASHER				0.50	
TOTAL =					541.20

ENERGY COSTS TO: ILLINOIS DEPARTMENT OF TRANSPORTATION
 201 WEST CENTER COURT
 SCHLAUBURG, ILLINOIS 60196-1096
 CONTACT: MIKE LYNCH
 PHONE: (847) 816-5331
 COMPANY: COM. EDISON

FOUNDATION (DEPTH)	FT. (m)	CABLE SLACK	FT. (m)	VERTICAL	FT. (m)
TYPE A - POST	4 (1.2)	HANDHOLE	6.5 (2.0)	ALL FOUNDATIONS	3.5 (1.0)
D - CONTROLLER	4 (1.2)	DOUBLE HANDHOLE	13 (4.0)	MAST ARM (L) POLE	20'+L-2' (6m+L-0.6m)
E - M. ARM POLE		SIGNAL POST	2 (1.0)		
	30" (750mm)	CONTROLLER CAB.	1 (0.5)	BRACKET MOUNTED	13 (4.0)
	36" (900mm)	FIBER OPTIC	13 (4.0)	PED. PUSHBUTTON	4 (1.2)
	36" (900mm)	ELECTRIC SERVICE	1 (0.5)	ELECTRIC SERVICE	13.5 (4.1)
	36" (900mm)	GROUND CABLE	1 (0.5)	SERVICE TO GROUND	13.5 (4.1)
				POST MOUNTED	6 (1.8)

REVISIONS	
NAME	DATE

ILLINOIS DEPARTMENT OF TRANSPORTATION
 US RTE 6 FROM I-294 TO IL RTE 1

TEMPORARY CABLE PLAN US RTE 6 & HALSTED STREET

SCALE: NONE
 DATE 01/28/09
 DRAWN BY DK
 CHECKED BY JA

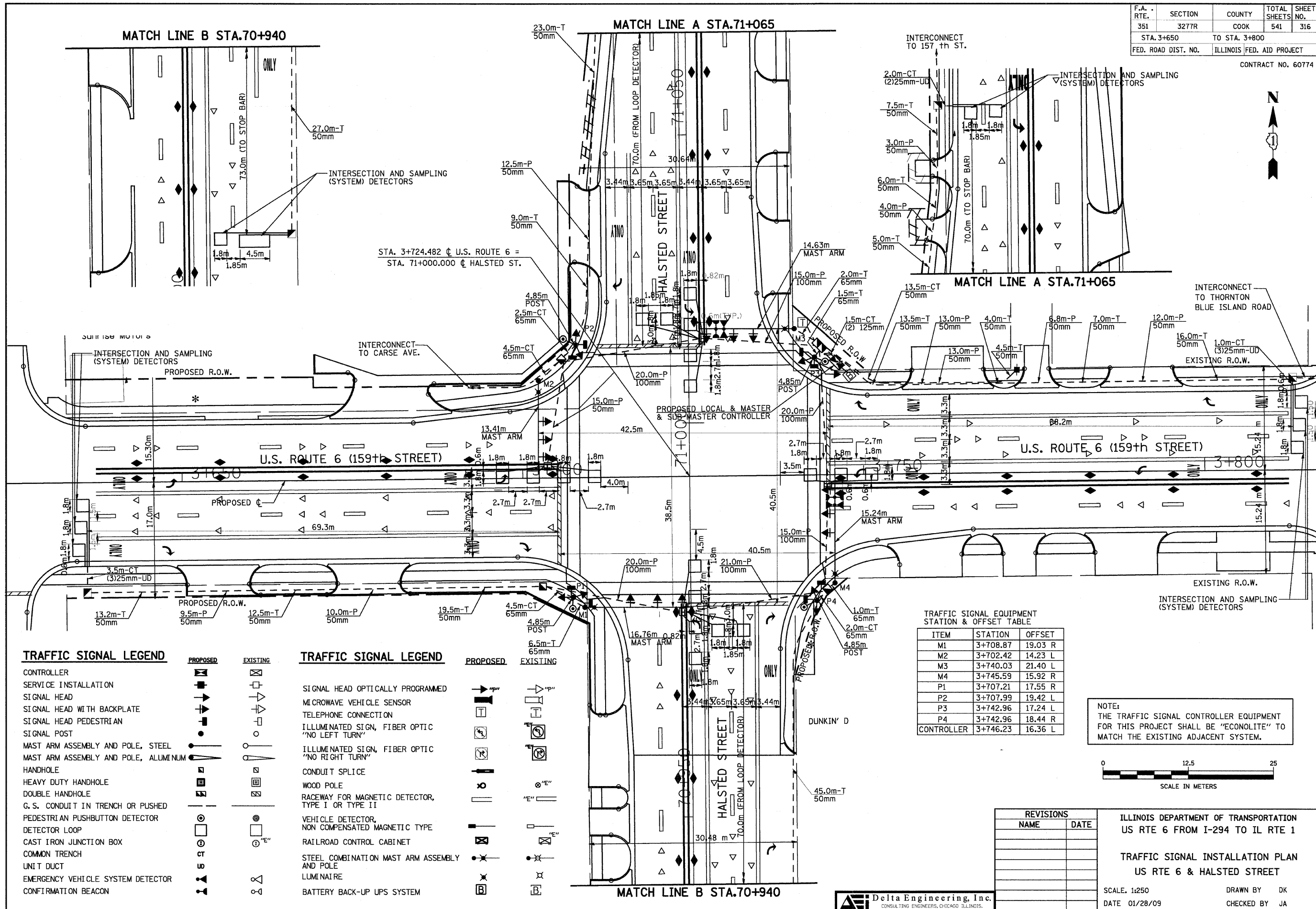

TRAFFIC SIGNAL LEGEND

	PROPOSED	EXISTING
CONTROLLER		
SERVICE INSTALLATION		
SIGNAL HEAD		
SIGNAL HEAD WITH BACKPLATE		
SIGNAL HEAD PEDESTRIAN		
SIGNAL POST		
MAST ARM ASSEMBLY AND POLE, STEEL		
MAST ARM ASSEMBLY AND POLE, ALUMINUM		
HANDHOLE		
HEAVY DUTY HANDHOLE		
DOUBLE HANDHOLE		
G. S. CONDUIT IN TRENCH OR PUSHED		
PEDESTRIAN PUSHBUTTON DETECTOR		
DETECTOR LOOP		
CAST IRON JUNCTION BOX		
COMMON TRENCH		
UNIT DUCT		
EMERGENCY VEHICLE SYSTEM DETECTOR		
CONFIRMATION BEACON		

TRAFFIC SIGNAL LEGEND

	PROPOSED	EXISTING
SIGNAL HEAD OPTICALLY PROGRAMMED		
MICROWAVE VEHICLE SENSOR		
TELEPHONE CONNECTION		
ILLUMINATED SIGN, FIBER OPTIC "NO LEFT TURN"		
ILLUMINATED SIGN, FIBER OPTIC "NO RIGHT TURN"		
CONDUIT SPLICE		
WOOD POLE		
RACEWAY FOR MAGNETIC DETECTOR, TYPE I OR TYPE II		
VEHICLE DETECTOR, NON COMPENSATED MAGNETIC TYPE		
RAILROAD CONTROL CABINET		
STEEL COMBINATION MAST ARM ASSEMBLY AND POLE		
LUMINAIRE		
BATTERY BACK-UP UPS SYSTEM		

TRAFFIC SIGNAL EQUIPMENT STATION & OFFSET TABLE

ITEM	STATION	OFFSET
M1	3+708.87	19.03 R
M2	3+702.42	14.23 L
M3	3+740.03	21.40 L
M4	3+745.59	15.92 R
P1	3+707.21	17.55 R
P2	3+707.99	19.42 L
P3	3+742.96	17.24 L
P4	3+742.96	18.44 R
CONTROLLER	3+746.23	16.36 L

NOTE:
THE TRAFFIC SIGNAL CONTROLLER EQUIPMENT FOR THIS PROJECT SHALL BE "ECONOLITE" TO MATCH THE EXISTING ADJACENT SYSTEM.

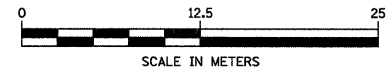

REVISIONS	
NAME	DATE

ILLINOIS DEPARTMENT OF TRANSPORTATION
US RTE 6 FROM I-294 TO IL RTE 1

TRAFFIC SIGNAL INSTALLATION PLAN
US RTE 6 & HALSTED STREET

SCALE: 1:250
DATE 01/28/09

DRAWN BY DK
CHECKED BY JA

SCHEDULE OF QUANTITIES

PAY ITEM	UNIT	QTY
HANDHOLE	EACH	7
HEAVY-DUTY HANDHOLE	EACH	4
DOUBLE HANDHOLE	EACH	1
FULL-ACTUATED CONTROLLER AND TYPE V CABINET (SPECIAL)	EACH	1
TRANSCEIVER-FIBER OPTIC	EACH	1
TRAFFIC SIGNAL BACKPLATE	EACH	12
INDUCTIVE LOOP DETECTOR	EACH	16
*LIGHT DETECTOR	EACH	2
*LIGHT DETECTOR AMPLIFIER	EACH	1
PEDESTRIAN PUSH-BUTTON	EACH	4
TEMPORARY TRAFFIC SIGNAL INSTALLATION	EACH	1
REMOVE EXISTING TRAFFIC SIGNAL EQUIPMENT	EACH	1
REMOVE EXISTING HANDHOLE	EACH	6
REMOVE EXISTING CONCRETE FOUNDATION	EACH	6
SIGN PANEL - TYPE 2	SQ M	4.42
CONDUIT IN TRENCH, 50MM DIA., GALVANIZED STEEL	METER	325
CONDUIT IN TRENCH, 65MM DIA., GALVANIZED STEEL	METER	37
CONDUIT IN TRENCH, 100MM DIA., GALVANIZED STEEL	METER	96
CONDUIT PUSHED, 50MM DIA., GALVANIZED STEEL	METER	114
CONDUIT PUSHED, 100MM DIA., GALVANIZED STEEL	METER	120
TRENCH AND BACKFILL FOR ELECTRICAL WORK	METER	276
ELECTRIC CABLE IN CONDUIT, SIGNAL NO. 14 2C	METER	267
ELECTRIC CABLE IN CONDUIT, SIGNAL NO. 14 3C	METER	476
ELECTRIC CABLE IN CONDUIT, SIGNAL NO. 14 5C	METER	267
ELECTRIC CABLE IN CONDUIT, SIGNAL NO. 14 7C	METER	838
ELECTRIC CABLE IN CONDUIT, LEAD-IN, NO. 4 1 PAIR	METER	2734
ELECTRIC CABLE IN CONDUIT, SERVICE, NO. 6 2C	METER	30
TRAFFIC SIGNAL POST, GALVANIZED STEEL 4.85 METER	EACH	4
STEEL COMBINATION MAST ARM ASSEMBLY AND POLE, 9.75 METER	EACH	1
STEEL COMBINATION MAST ARM ASSEMBLY AND POLE, 10.97 METER	EACH	1
STEEL COMBINATION MAST ARM ASSEMBLY AND POLE, 11.58 METER	EACH	1
STEEL COMBINATION MAST ARM ASSEMBLY AND POLE, 12.19 METER	EACH	1
CONCRETE FOUNDATION, TYPE A	METER	4.8
CONCRETE FOUNDATION, TYPE D	METER	1.2
CONCRETE FOUNDATION, TYPE E 750 MM DIAMETER	METER	18.4
PREFORMED DETECTOR LOOP	METER	273
ELECTRIC CABLE IN CONDUIT, GROUNDING, NO. 6 1C	METER	321
ELECTRIC CABLE IN CONDUIT, NO. 20 3/C, TWISTED, SHIELDED	METER	196
TELEPHONE SERVICE INSTALLATION	L.SUM	0.5
SERVICE INSTALLATION, POLE MOUNT	EACH	1
SIGNAL HEAD, LED, 1-FACE, 3-SECTION, MAST ARM MOUNTED	EACH	4
SIGNAL HEAD, LED, 1-FACE, 5-SECTION, MAST ARM MOUNTED	EACH	8
SIGNAL HEAD, LED, 2-FACE, 5-SECTION, BRACKET MOUNTED	EACH	4
PEDESTRIAN SIGNAL HEAD, LED, 2-FACE, BRACKET MOUNTED WITH COUNTDOWN TIMER	EACH	4
TEMPORARY TRAFFIC SIGNAL TIMING	EACH	1
UNINTERRUPTABLE POWER SUPPLY	EACH	1

100% cost to City of Harvey

I.D.O.T. TRAFFIC SIGNAL INSTALLATION ELECTRICAL SERVICE REQUIREMENTS					TOTAL WATTAGE
TYPE	NO. LAMPS	WATTAGE INCAND.	WATTAGE LED	% OPERATION	
SIGNAL (RED)	20	135	17	0.50	170.0
SIGNAL (YELLOW)	20	135	25	0.25	125.0
SIGNAL (GREEN)	20	135	15	0.25	75.0
ARROW	32	135	12	0.10	38.4
PED. SIGNAL	8	90	25	1.00	200.0
CONTROLLER	1	100	100	1.00	100.0
ILLUM. SIGN		84		0.05	
FLASHER				0.50	
TOTAL =					708.40

ENERGY COSTS TO: ILLINOIS DEPARTMENT OF TRANSPORTATION
201 WEST CENTER COUR. SCHAUMBURG, ILLINOIS 60196-1096
CONTACT: MIKE LYNCH
PHONE: (847) 816-5331
COMPANY: COM. EDISON

FOUNDATION (DEPTH)	FT. (m)	CABLE SLACK	FT. (m)	VERTICAL	FT. (m)
TYPE A - POST	4 (1.2)	HANDHOLE	6.5 (2.0)	ALL FOUNDATIONS	3.5 (1.0)
D - CONTROLLER	4 (1.2)	DOUBLE HANDHOLE	13 (4.0)	MAST ARM (L) POLE	20'-H-2= (6m+H-0.6m)
E - M. ARM POLE		SIGNAL POST	2 (1.0)	BRACKET MOUNTED	13 (4.0)
	30" (750mm)	CONTROLLER CAB.	1 (0.5)	PED. PUSHBUTTON	4 (1.2)
	36" (900mm)	FIBER OPTIC	13 (4.0)	ELECTRIC SERVICE	13.5 (4.1)
	36" (900mm)	ELECTRIC SERVICE	1 (0.5)	SERVICE TO GROUND	13.5 (4.1)
	36" (900mm)	GROUND CABLE	1 (0.5)	POST MOUNTED	6 (1.8)

CABLE PLAN LEGEND

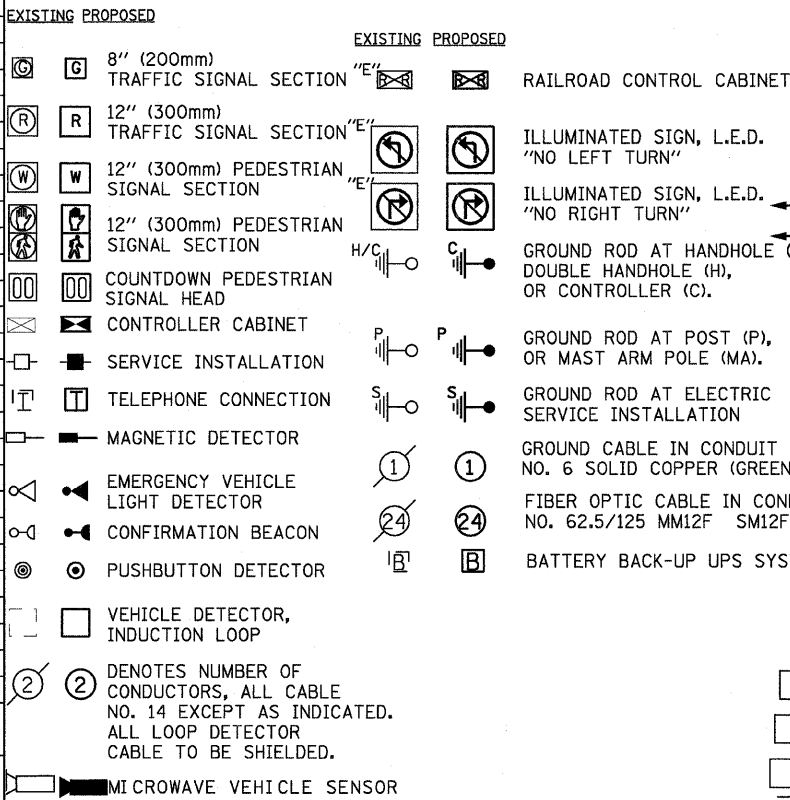

LEGEND

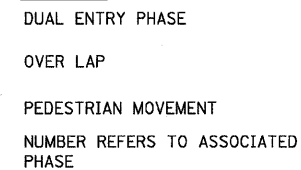

CONTROLLER SEQUENCE

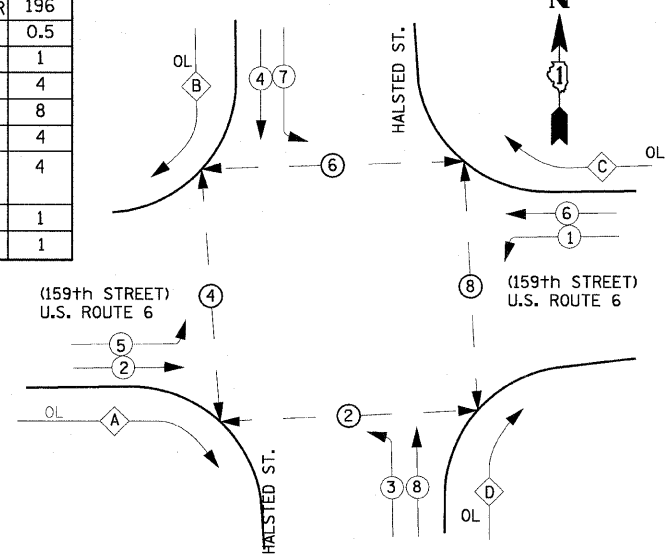

PREEMPTION SEQUENCE

PROPOSED EMERGENCY VEHICLE PREEMPTOR		
VEHICLE EMERGENCY PREEMPTOR	3	4
MOVEMENT	←	↑

PHASE DESIGNATION DIAGRAM

OVERLAP LETTER	PERMISSIVE PHASE	PROTECTED PHASE
A	= 2	+ 3
B	= 4	+ 5
C	= 6	+ 7
D	= 8	+ 1

Delta Engineering, Inc.
CONSULTING ENGINEERS, CHICAGO, ILLINOIS.

F.A. RTE.	SECTION	COUNTY	TOTAL SHEETS	SHEET NO.
351	3277R	COOK	541	317

STA. TO STA.
FED. ROAD DIST. NO. ILLINOIS FED. AID PROJECT

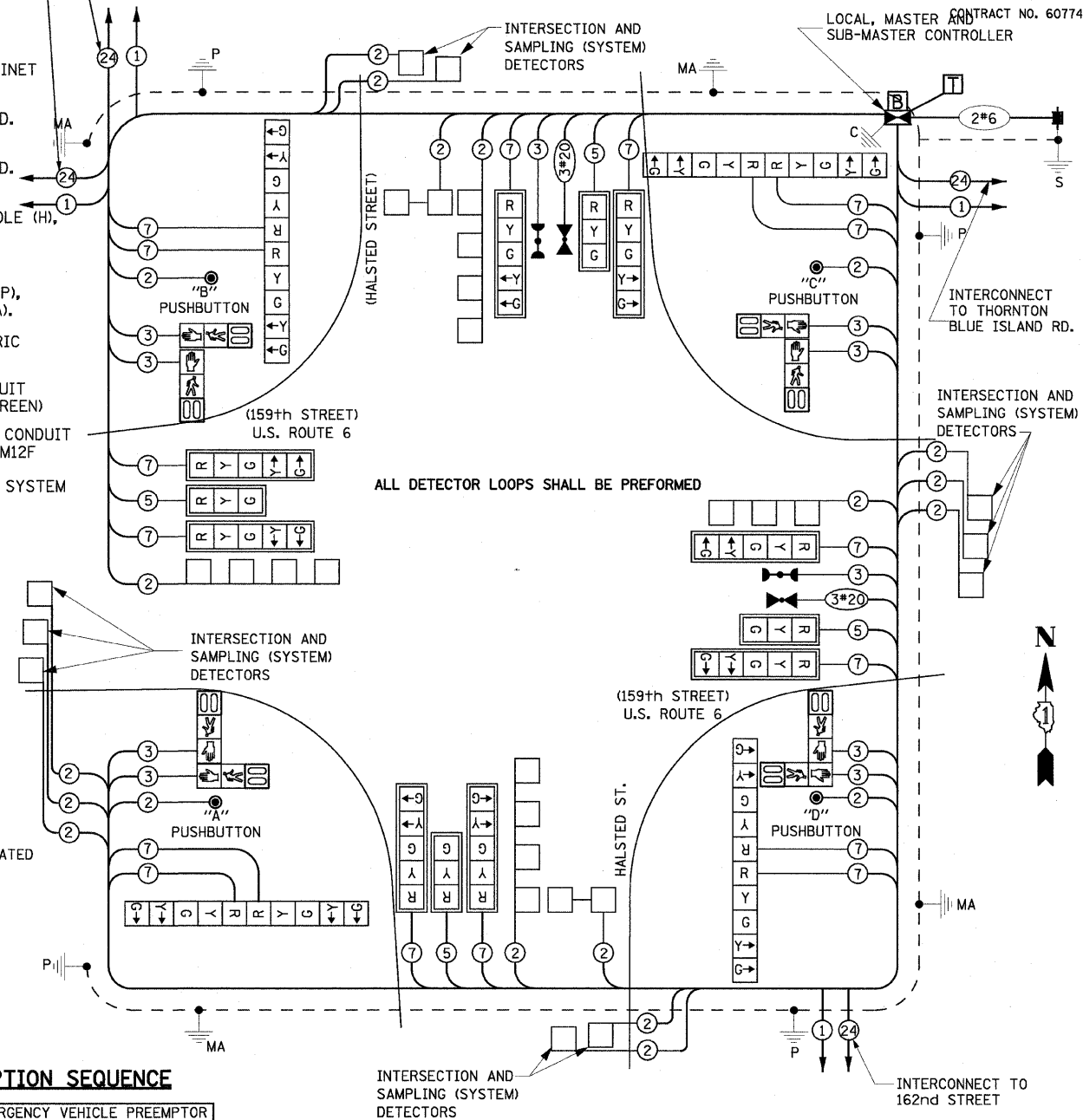

NOTE:

PUSHBUTTON "A" SHALL PLACE A CALL IN PHASES 2 AND 4
PUSHBUTTON "B" SHALL PLACE A CALL IN PHASES 4 AND 6
PUSHBUTTON "C" SHALL PLACE A CALL IN PHASES 6 AND 8
PUSHBUTTON "D" SHALL PLACE A CALL IN PHASES 2 AND 8

NOTE:

THE TRAFFIC SIGNAL CONTROLLER EQUIPMENT FOR THIS PROJECT SHALL BE "ECONOLITE" TO MATCH THE EXISTING ADJACENT SYSTEM.

REVISIONS	
NAME	DATE

ILLINOIS DEPARTMENT OF TRANSPORTATION
US RTE 6 FROM I-294 TO IL RTE 1
SCHEDULE OF QUANTITIES AND CABLE PLAN
US RTE 6 & HALSTED STREET

SCALE: NONE
DATE 01/28/09
DRAWN BY DK
CHECKED BY JA

EXAMPLE, 2 ³ DENOTES 3/8"

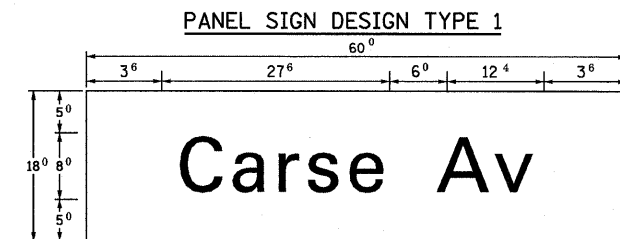

0.70 Sq. M. each
 7.50 Sq. Ft. each
 2 Required
 Design Series D

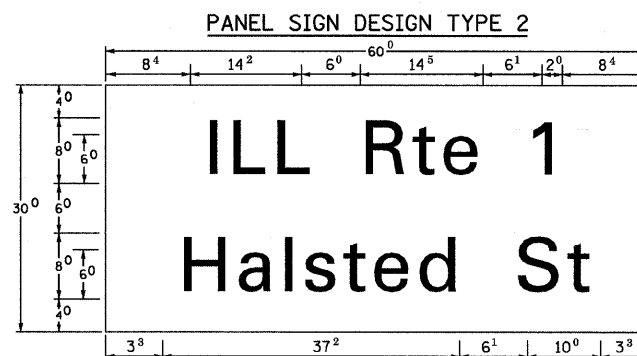
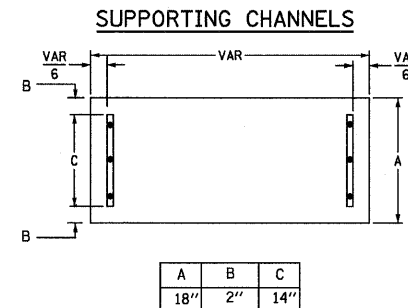

1.16 Sq. M. each
 12.50 Sq. Ft. each
 2 Required
 Design Series D

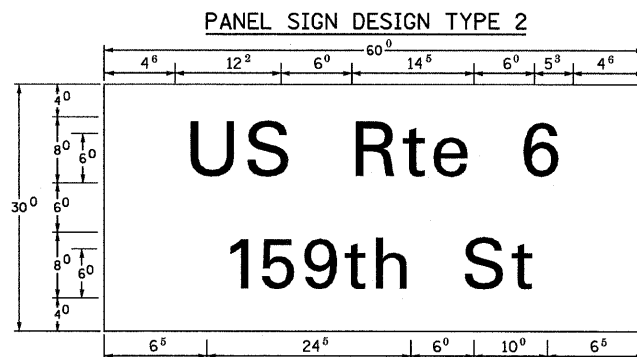
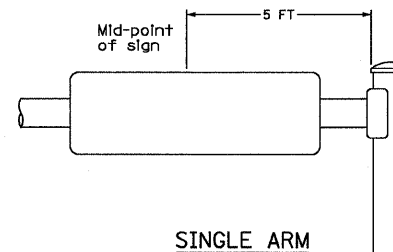

1.05 Sq. M. each
 11.25 Sq. Ft. each
 10 Required
 Design Series D

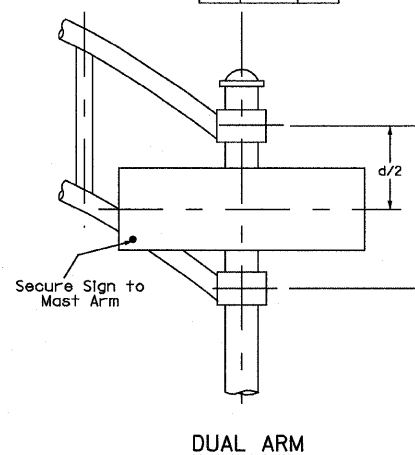
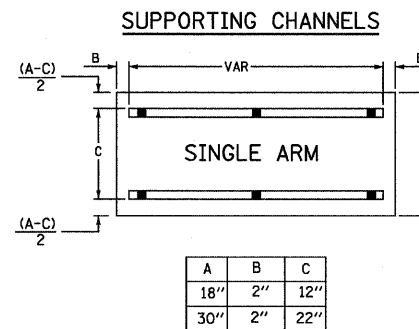

GENERAL NOTES

- WHERE MAST ARM MOUNTED STREET NAME SIGNS ARE SPECIFIED, THE MAST ARM ASSEMBLY AND POLES SHALL BE DESIGNED TO SUPPORT THE LOADINGS CALLED FOR IN STANDARDS 834001, 834006 AND 834011, AS APPLICABLE, PLUS A 2'-6" BY 6'-0" SIGN PANEL MOUNTED AS SHOWN. THE DESIGN SHALL BE IN ACCORDANCE WITH THE REQUIREMENTS OF THE CURRENT "STANDARD SPECIFICATIONS FOR STRUCTURAL SUPPORTS FOR HIGHWAY SIGNS, LUMINAIRES AND TRAFFIC SIGNALS" AS PUBLISHED BY THE AMERICAN ASSOCIATION OF STATE HIGHWAY AND TRANSPORTATION OFFICIALS FOR 80 M.P.H. WIND VELOCITY.
- ALL SIGNS SHALL HAVE A WHITE REFLECTORIZED LEGEND AND BORDER ON A GREEN REFLECTORIZED BACKGROUND. TYPE A SHEETING.
- THE SIGN LENGTH SHOULD BE INCREASED IN 6-INCH INCREMENTS, BUT THE OVERALL LENGTH SHOULD NOT EXCEED 6'-0".
- ALL BORDERS SHALL BE 3/4" WIDE AND CORNER RADIUS SHALL BE 2 1/2".
- SIGNFIX ALUMINUM CHANNEL FRAMING SYSTEM SHALL BE FOR ALL SIGNS ATTACHED TO SIGNAL POLES AND POSTS. LOCAL SUPPLIERS OF SIGNFIX ALUMINUM CHANNEL FRAMING SYSTEM ARE:

A.K.T. CORPORATION SCHAUMBURG, IL. TUCKER COMPANY, INC. WAUWATOSA, WI.	AMERICAN FABRICATION CO. CHICAGO HEIGHTS, IL. WESTERN TRAFFIC CONTROL INC. CICERO, IL.
PARTS LISTING	
SIGN CHANNEL	PART # HPN053 (MED. CHANNEL)
SIGN SCREWS	1/4" X 14 X 1" H.W.H. #3 SELF TAPPING WITH NEOPREAN WASHER
BRACKETS	PART # HPN034 (UNIVERSAL) CHANNEL CLAMPS WITH STAINLESS STEEL STRAPPING

OTHER BRANDS OF MOUNTING HARDWARE ARE ACCEPTABLE, BASED UPON THE DEPARTMENT'S APPROVAL AND COMPATIBILITY WITH THE CHANNEL/BACKET OF THE ABOVE PRODUCT.

SIGNFIX ALUMINUM CHANNEL FRAMING SYSTEM shall be used. See Note #5.

Upper Case To Lower Case Spacing Chart 8-6 Inch Series "C & D"

SERIES	SECOND LETTER																
	aode goq		bhkl mnpru		f w		J		s t		v y		x z				
A W X	1 ²	1 ⁴	1 ⁴	1 ⁵	1 ²	1 ⁴	0 ⁶	1 ⁰	1 ¹	1 ⁴	0 ⁶	1 ⁰	1 ¹	1 ²	1 ⁴		
B	1 ⁴	1 ⁵	2 ⁰	2 ¹	1 ⁴	1 ⁵	1 ¹	1 ²	1 ⁴	1 ⁵	1 ²	1 ⁴	1 ²	1 ⁴	1 ⁶	1 ⁷	
C E G	1 ⁴	1 ⁵	2 ⁰	2 ¹	1 ²	1 ⁴	0 ⁶	1 ⁰	1 ²	1 ⁴	1 ²	1 ⁴	1 ⁴	1 ⁵	1 ⁴	1 ⁵	
D O Q R	1 ⁴	1 ⁵	2 ⁰	2 ¹	1 ⁴	1 ⁵	0 ⁶	1 ⁰	1 ²	1 ⁴	1 ²	1 ⁴	1 ⁴	1 ⁵	1 ⁴	1 ⁵	
F	0 ⁵	0 ⁶	1 ⁴	1 ⁵	0 ⁶	1 ⁰	0 ⁵	0 ⁶	1 ⁰	0 ⁶	1 ⁰	0 ⁶	1 ⁰	0 ⁶	1 ⁰	1 ¹	1 ²
H I M N	2 ⁰	2 ¹	2 ²	2 ⁴	2 ⁰	2 ¹	1 ⁴	1 ⁵	1 ⁶	1 ⁷	1 ⁶	1 ⁷	2 ⁰	2 ¹	2 ⁰	2 ¹	
J U	2 ⁰	2 ¹	2 ⁰	2 ¹	1 ⁶	1 ⁷	1 ⁴	1 ⁵	1 ⁶	1 ⁷	1 ⁶	1 ⁷	1 ⁶	1 ⁷	2 ⁰	2 ¹	
K L	1 ¹	1 ²	1 ⁶	1 ⁷	1 ¹	1 ²	0 ⁵	0 ⁶	1 ¹	1 ²	1 ¹	1 ²	1 ¹	1 ²	1 ⁴	1 ⁴	
P	1 ²	1 ⁴	1 ⁴	1 ⁵	1 ²	1 ⁴	0 ⁵	0 ⁶	1 ¹	1 ²	1 ¹	1 ²	1 ¹	1 ²	1 ⁴	1 ⁴	
S	1 ²	1 ⁴	1 ⁶	1 ⁷	1 ²	1 ⁴	0 ⁵	0 ⁶	1 ¹	1 ²	1 ¹	1 ²	1 ¹	1 ²	1 ⁴	1 ⁴	
T	1 ¹	1 ²	1 ⁶	1 ⁷	0 ⁶	1 ⁰	0 ⁶	1 ⁰	1 ¹	1 ²	1 ¹	1 ²	1 ¹	1 ²	1 ⁴	1 ⁴	
V	0 ⁶	1 ⁰	1 ⁴	1 ⁵	1 ¹	1 ²	0 ⁶	1 ⁰	1 ²	1 ⁴	1 ²	1 ⁴	1 ²	1 ⁴	1 ²	1 ⁴	
Y	0 ⁵	0 ⁶	1 ⁴	1 ⁵	0 ⁶	1 ⁰	0 ⁵	0 ⁶	0 ⁵	0 ⁷	0 ⁵	0 ⁶	0 ⁶	1 ⁰	1 ¹	1 ²	
Z	1 ⁶	1 ⁷	2 ²	2 ⁴	1 ⁶	1 ⁷	1 ²	1 ⁴	1 ⁶	1 ⁷	1 ⁶	1 ⁷	1 ⁶	1 ⁷	2 ⁰	2 ¹	

Lower Case To Lower Case Spacing Chart 6 Inch Series "C & D"

SERIES	SECOND LETTER															
	aode goq		bhkl mnpru		f w		J		s t		v y		x z			
adgjl lmnqu	1 ⁶	1 ⁷	2 ²	2 ⁴	1 ⁶	1 ⁷	1 ²	1 ⁴	1 ⁴	1 ⁵	1 ⁴	1 ⁵	1 ⁶	1 ⁷	1 ⁶	1 ⁷
bfkops	1 ²	1 ⁴	1 ⁶	1 ⁷	1 ¹	1 ²	0 ⁵	0 ⁶	1 ¹	1 ²	1 ¹	1 ²	1 ¹	1 ²	1 ⁴	1 ⁴
ce	1 ²	1 ⁴	1 ⁶	1 ⁷	1 ²	1 ⁴	0 ⁶	1 ⁰	1 ²	1 ⁴	1 ²	1 ⁴	1 ²	1 ⁴	1 ²	1 ⁴
r	0 ⁶	1 ⁰	1 ²	1 ⁴	0 ⁶	1 ⁰	0 ³	0 ³	0 ⁵	0 ⁶	0 ⁵	0 ⁶	0 ⁶	1 ⁰	0 ⁶	1 ⁰
tz	1 ²	1 ⁴	1 ⁶	1 ⁷	1 ²	1 ⁴	0 ⁶	1 ⁰	1 ¹	1 ²	1 ¹	1 ²	1 ¹	1 ²	1 ⁴	1 ⁴
vy	1 ¹	1 ²	1 ⁴	1 ⁵	1 ¹	1 ²	0 ⁵	0 ⁶	0 ⁶	1 ⁰	0 ⁶	1 ⁰	1 ¹	1 ²	1 ¹	1 ²
w	1 ¹	1 ²	1 ⁴	1 ⁵	1 ¹	1 ²	0 ⁵	0 ⁶	1 ¹	1 ²	1 ¹	1 ²	1 ¹	1 ²	1 ⁴	1 ⁴
x	1 ²	1 ⁴	1 ⁶	1 ⁷	1 ¹	1 ²	0 ⁵	0 ⁶	1 ¹	1 ²	1 ¹	1 ²	1 ¹	1 ²	1 ⁴	1 ⁴

Number to Number Spacing Chart 8 Inch Series "C & D"

SERIES	SECOND NUMBER																					
	0	1	2	3	4	5	6	7	8	9												
0 9	1 ⁶	1 ⁷	1 ⁶	1 ⁷	1 ⁴	1 ⁵	2 ⁴	1 ⁴	1 ⁵	1 ⁴	1 ⁵	1 ⁴	1 ⁵	1 ⁶	1 ⁷	1 ⁶	1 ⁷					
1	2 ⁰	2 ¹	2 ⁰	2 ¹	2 ⁰	2 ¹	1 ⁶	1 ⁷	1 ⁴	1 ⁵	2 ⁰	2 ¹	2 ⁰	2 ¹	1 ⁴	1 ⁵	2 ⁰	2 ¹				
2 3 4	1 ⁴	1 ⁵	1 ⁴	1 ⁵	1 ⁴	1 ⁵	1 ²	1 ⁴	1 ²	1 ⁴	1 ⁵	1 ⁴	1 ⁵	1 ¹	1 ²	1 ⁴	1 ⁵	1 ⁴	1 ⁵			
5	1 ⁴	1 ⁵	1 ⁴	1 ⁵	1 ⁴	1 ⁵	1 ¹	1 ²	1 ¹	1 ²	1 ⁴	1 ⁵	1 ⁴	1 ⁵	1 ¹	1 ²	1 ⁴	1 ⁵	1 ⁴	1 ⁵		
6	1 ⁶	1 ⁷	1 ⁴	1 ⁵	1 ⁴	1 ⁵	1 ²	1 ⁴	1 ²	1 ⁴	1 ⁵	1 ⁴	1 ⁵	1 ¹	1 ²	1 ⁴	1 ⁵	1 ⁴	1 ⁵	1 ⁴	1 ⁵	
7	1 ²	1 ⁴	1 ²	1 ⁴	1 ⁴	1 ⁵	1 ²	1 ⁵	0 ⁶	1 ²	1 ⁴	1 ⁴	1 ⁵	1 ¹	1 ²	1 ⁴	1 ⁵	1 ²	1 ⁴	1 ⁴	1 ⁵	
8	1 ⁶	1 ⁷	1 ⁶	1 ⁷	1 ⁴	1 ⁵	1 ²	1 ⁵	1 ²	1 ⁴	1 ⁴	1 ⁵	1 ⁶	1 ⁷	1 ²	1 ⁴	1 ⁶	1 ⁷	1 ⁴	1 ⁵	1 ⁶	1 ⁷

UPPER AND LOWER CASE LETTER WIDTHS

LETTERS	6 INCH UPPER CASE LETTERS		8 INCH UPPER CASE LETTERS		LETTERS	6 INCH LOWER CASE LETTERS	
	C	D	C	D		C	D
A	3 ⁶	5 ⁰	5 ⁰	6 ⁵	a	3 ⁵	4 ²
B	3 ²	4 ⁰	4 ³	5 ³	b	3 ⁵	4 ²
C	3 ²	4 ⁰	4 ³	5 ³	c	3 ⁵	4 ¹
D	3 ²	4 ⁰	4 ³	5 ³	d	3 ⁵	4 ²
E	3 ⁰	3 ⁵	4 ⁰	4 ⁷	e	3 ⁵	4 ²
F	3 ⁰	3 ⁵	4 ⁰	4 ⁷	f	2 ³	2 ⁶
G	3 ²	4 ⁰	4 ³	5 ³	g	3 ⁵	4 ²
H	3 ²	4 ⁰	4 ³	5 ³	h	3 ⁵	4 ²
I	0 ⁷	0 ⁷	1 ¹	1 ²	i	1 ¹	1 ¹
J	3 ⁰	3 ⁶	4 ⁰	5 ⁰	j	2 ⁰	2 ²
K	3 ²	4 ¹	4 ³	5 ⁴	k	3 ⁵	4 ²
L	3 ⁰	3 ⁵	4 ⁰	4 ⁷	l	1 ¹	1 ¹
M	3 ⁷	4 ⁵	5 ¹	6 ¹	m	6 ⁰	7 ⁰
N	3 ²	4 ⁰	4 ³	5 ³	n	3 ⁵	4 ²
O	3 ⁴	4 ²	4 ⁵	5 ⁵	o	3 ⁶	4 ³
P	3 ²	4 ⁰	4 ³	5 ³	p	3 ⁵	4 ²
Q	3 ⁴	4 ²	4 ⁵	5 ⁵	q	3 ⁵	4 ²
R	3 ²	4 ⁰	4 ³	5 ³	r	2 ⁶	3 ²
S	3 ²	4 ⁰	4 ³	5 ³	s	3 ⁶	4 ²
T	3 ⁰	3 ⁵	4 ⁰	4 ⁷	t	2 ⁷	3 ²
U	3 ²	4 ⁰	4 ³	5 ³	u	3 ⁵	4 ²
V	3 ⁵	4 ⁴	4 ⁷	6 ⁰	v	4 ²	4 ⁷
W	4 ⁴	5 ²	6 ⁰	7 ⁰	w	5 ⁵	6 ⁴
x	3 ⁴	4 ⁰	4 ⁵	5 ³	x	4 ⁴	5 ¹
Y	3 ⁶	5 ⁰	5 ⁰	6 ⁶	y	4 ⁶	5 ³
Z	3 ²	4 ⁰	4 ³	5 ³	z	3 ⁶	4 ³

NUMBER

NUMBER	6 INCH SERIES		8 INCH SERIES	
	C	D	C	D
1	1 ²	1 ⁴	1 ⁵	2 ⁰
2	3 ²	4 ⁰	4 ³	5 ³
3	3 ²	4 ⁰	4 ³	5 ³
4	3 ⁵	4 ³	4 ⁷	5 ⁷
5	3 ²	4 ⁰	4 ³	5 ³
6	3 ²	4 ⁰	4 ³	5 ³
7	3 ²	4 ⁰	4 ³	5 ³
8	3 ²	4 ⁰	4 ³	5 ³
9	3 ²	4 ⁰	4 ³	5 ³
0	3 ⁴	4 ²	4 ⁵	5 ⁵

REVISIONS

NAME	DATE

F.A.P. RTE.	SECTION	COUNTY	TOTAL SHEETS	SHEET NO.
351	3277R	COOK	541	320
STA. 1+000		TO STA. 1+600		
FED. ROAD DIST. NO.		ILLINOIS FED. AID PROJECT		
CONTRACT NO. 60774				

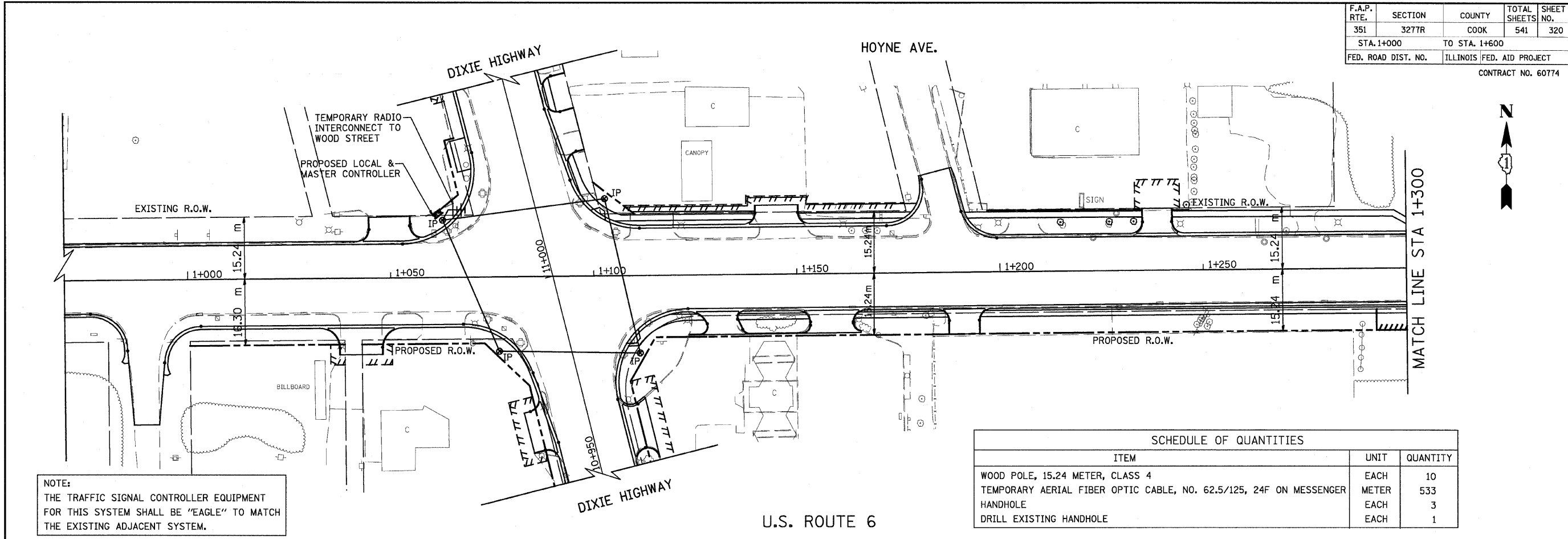

NOTE:
THE TRAFFIC SIGNAL CONTROLLER EQUIPMENT FOR THIS SYSTEM SHALL BE "EAGLE" TO MATCH THE EXISTING ADJACENT SYSTEM.

SCHEDULE OF QUANTITIES		
ITEM	UNIT	QUANTITY
WOOD POLE, 15.24 METER, CLASS 4	EACH	10
TEMPORARY AERIAL FIBER OPTIC CABLE, NO. 62.5/125, 24F ON MESSENGER	METER	533
HANDHOLE	EACH	3
DRILL EXISTING HANDHOLE	EACH	1

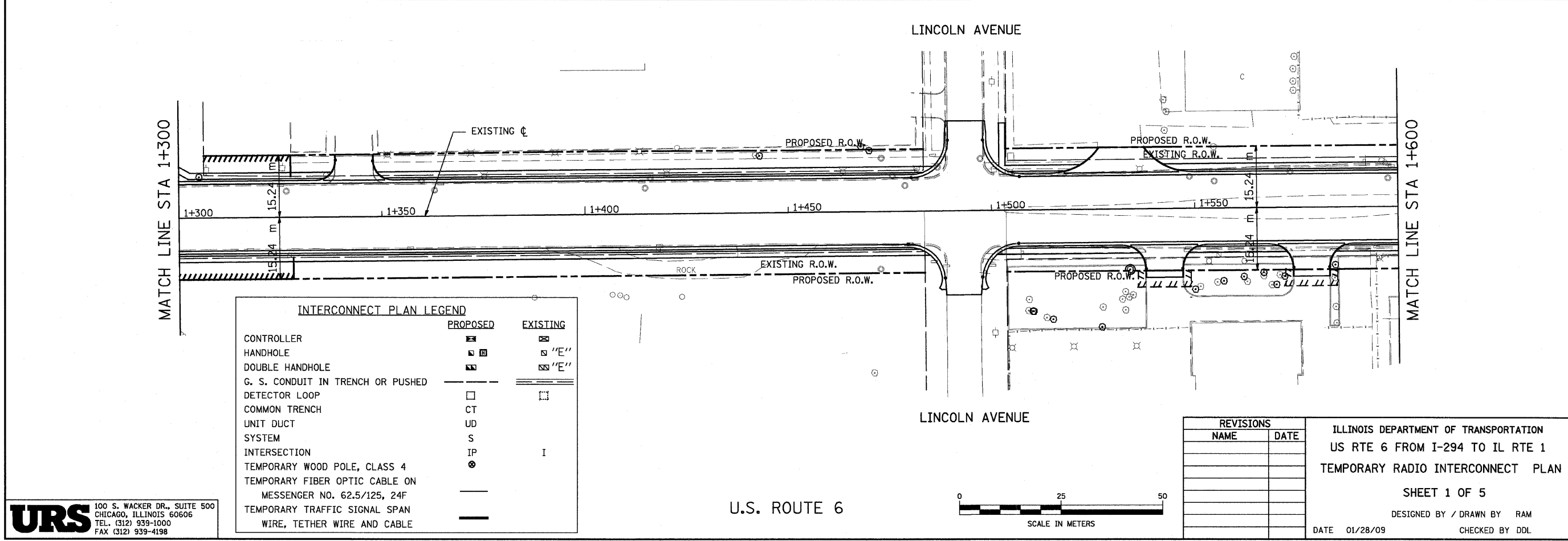

INTERCONNECT PLAN LEGEND		
	PROPOSED	EXISTING
CONTROLLER	⊠	⊠
HANDHOLE	⊠	⊠ "E"
DOUBLE HANDHOLE	⊠	⊠ "E"
G. S. CONDUIT IN TRENCH OR PUSHED	---	---
DETECTOR LOOP	□	□
COMMON TRENCH	CT	
UNIT DUCT	UD	
SYSTEM	S	
INTERSECTION	IP	I
TEMPORARY WOOD POLE, CLASS 4	⊙	
TEMPORARY FIBER OPTIC CABLE ON MESSENGER NO. 62.5/125, 24F	---	
TEMPORARY TRAFFIC SIGNAL SPAN WIRE, TETHER WIRE AND CABLE	---	

REVISIONS	
NAME	DATE

ILLINOIS DEPARTMENT OF TRANSPORTATION
US RTE 6 FROM I-294 TO IL RTE 1
TEMPORARY RADIO INTERCONNECT PLAN
SHEET 1 OF 5
DESIGNED BY / DRAWN BY RAM
DATE 01/28/09 CHECKED BY DDL

URS 100 S. WACKER DR., SUITE 500
CHICAGO, ILLINOIS 60606
TEL. (312) 939-1000
FAX (312) 939-4198

F.A.P. RTE.	SECTION	COUNTY	TOTAL SHEETS	SHEET NO.
351	3277R	COOK	541	321
STA. 1+600		TO STA. 2+150		
FED. ROAD DIST. NO.		ILLINOIS FED. AID PROJECT		

CONTRACT NO. 60774

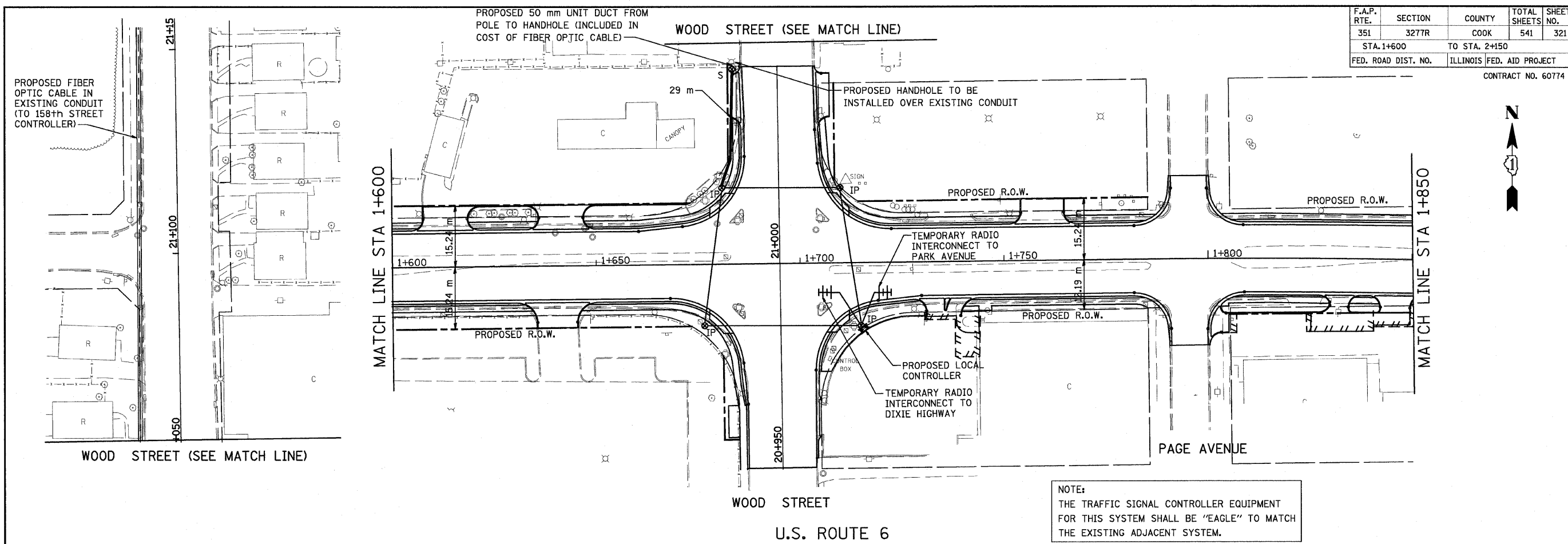

NOTE:
THE TRAFFIC SIGNAL CONTROLLER EQUIPMENT FOR THIS SYSTEM SHALL BE "EAGLE" TO MATCH THE EXISTING ADJACENT SYSTEM.

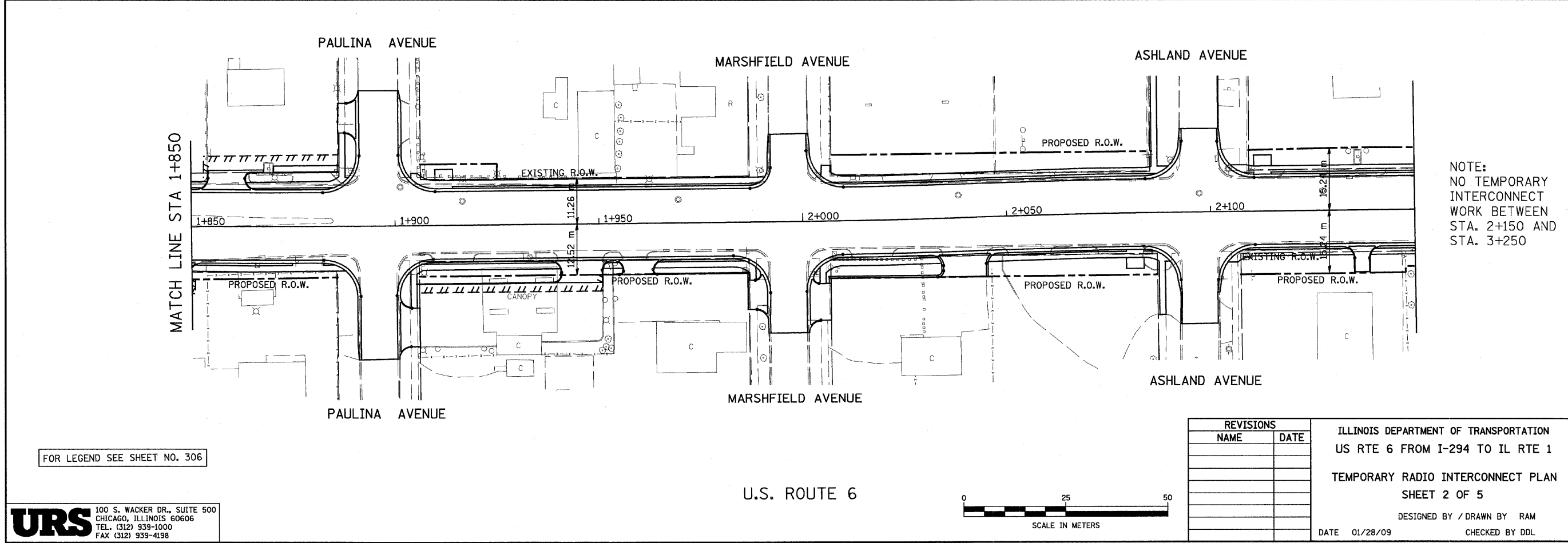

NOTE:
NO TEMPORARY INTERCONNECT WORK BETWEEN STA. 2+150 AND STA. 3+250

FOR LEGEND SEE SHEET NO. 306

URS 100 S. WACKER DR., SUITE 500
CHICAGO, ILLINOIS 60606
TEL. (312) 939-1000
FAX (312) 939-4198

REVISIONS	
NAME	DATE

ILLINOIS DEPARTMENT OF TRANSPORTATION
US RTE 6 FROM I-294 TO IL RTE 1
TEMPORARY RADIO INTERCONNECT PLAN
SHEET 2 OF 5
DESIGNED BY / DRAWN BY RAM
DATE 01/28/09 CHECKED BY DDL

F.A.P. RTE.	SECTION	COUNTY	TOTAL SHEETS	SHEET NO.
351	3277R	COOK	541	322
STA. 3+250		TO STA. 3+850		
FED. ROAD DIST. NO.	ILLINOIS	FED. AID PROJECT		

CONTRACT NO. 60774

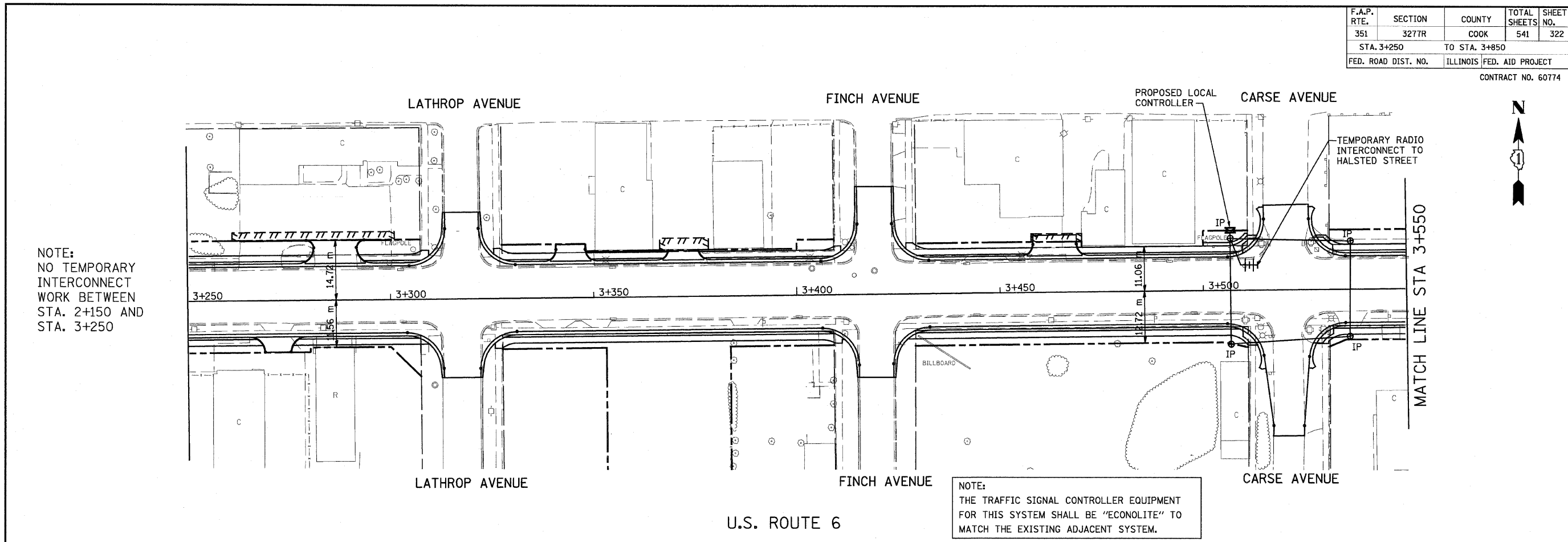

NOTE:
NO TEMPORARY INTERCONNECT WORK BETWEEN STA. 2+150 AND STA. 3+250

NOTE:
THE TRAFFIC SIGNAL CONTROLLER EQUIPMENT FOR THIS SYSTEM SHALL BE "ECONOLITE" TO MATCH THE EXISTING ADJACENT SYSTEM.

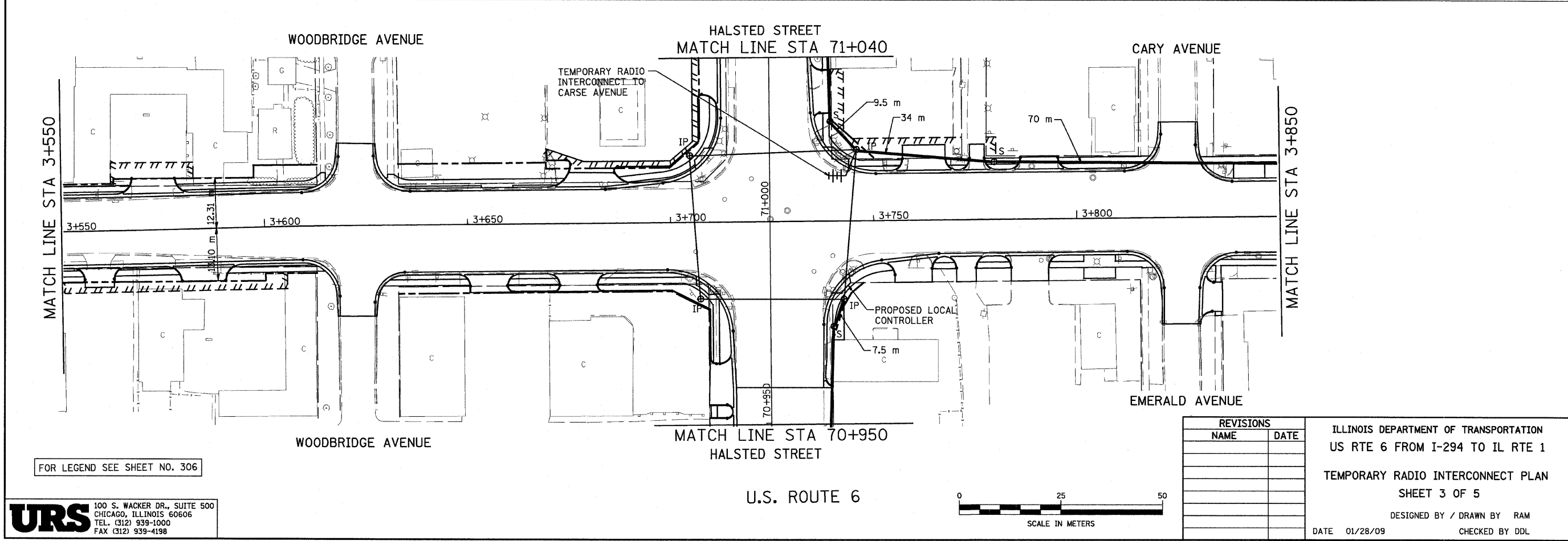

FOR LEGEND SEE SHEET NO. 306

URS
100 S. WACKER DR., SUITE 500
CHICAGO, ILLINOIS 60606
TEL. (312) 939-1000
FAX (312) 939-4198

REVISIONS	
NAME	DATE

ILLINOIS DEPARTMENT OF TRANSPORTATION
US RTE 6 FROM I-294 TO IL RTE 1
TEMPORARY RADIO INTERCONNECT PLAN
SHEET 3 OF 5
DESIGNED BY / DRAWN BY RAM
DATE 01/28/09 CHECKED BY DDL

F.A.P. RTE.	SECTION	COUNTY	TOTAL SHEETS	SHEET NO.
351	327TR	COOK	541	323
STA. 3+850		TO STA. 3+973		
FED. ROAD DIST. NO.		ILLINOIS FED. AID PROJECT		
CONTRACT NO. 60774				

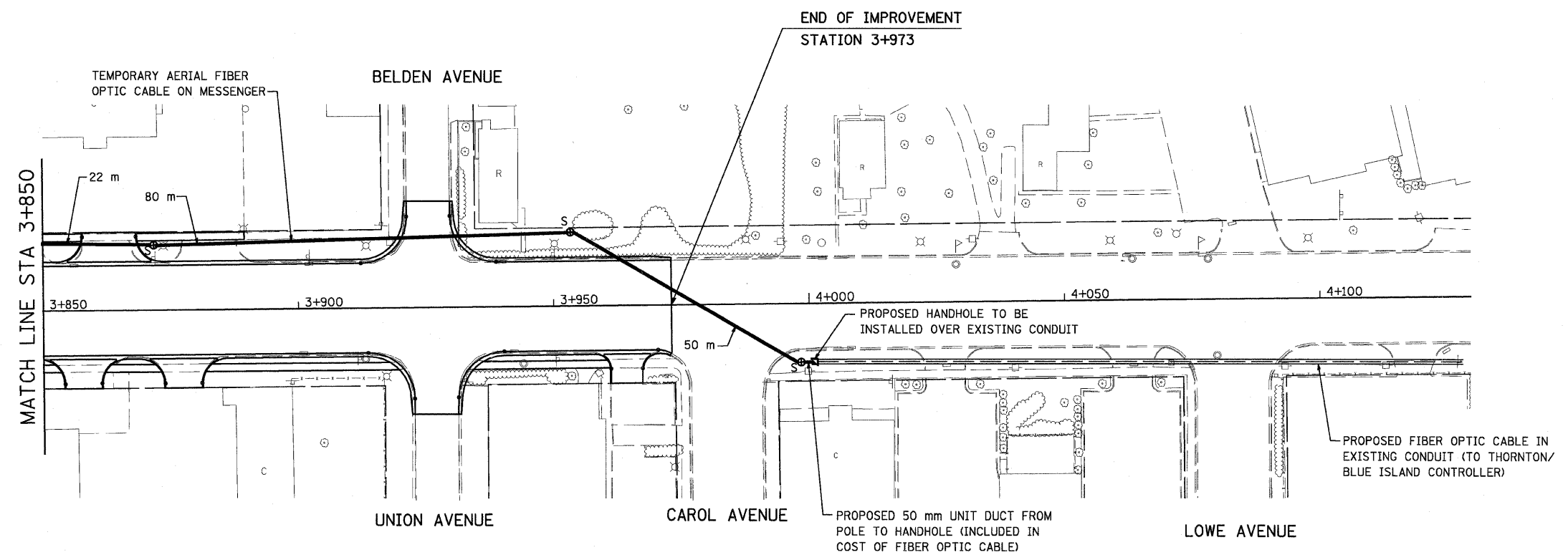

NOTE:
 THE TRAFFIC SIGNAL CONTROLLER EQUIPMENT FOR THIS SYSTEM SHALL BE "ECONLITE" TO MATCH THE EXISTING ADJACENT SYSTEM.

FOR LEGEND SEE SHEET NO. 306

URS
 100 S. WACKER DR., SUITE 500
 CHICAGO, ILLINOIS 60606
 TEL. (312) 939-1000
 FAX (312) 939-4198

U.S. ROUTE 6

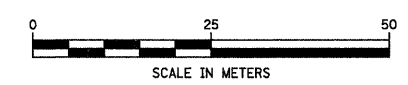

REVISIONS	
NAME	DATE

ILLINOIS DEPARTMENT OF TRANSPORTATION
 US RTE 6 FROM I-294 TO IL RTE 1
 TEMPORARY RADIO INTERCONNECT PLAN
 SHEET 4 OF 5
 DESIGNED BY / DRAWN BY RAM
 DATE 01/28/09 CHECKED BY DDL

F.A.P. RTE.	SECTION	COUNTY	TOTAL SHEETS	SHEET NO.
351	3277R	COOK	541	324
STA. 70+900		TO STA. 71+194.315		
FED. ROAD DIST. NO.		ILLINOIS FED. AID PROJECT		
CONTRACT NO. 60774				

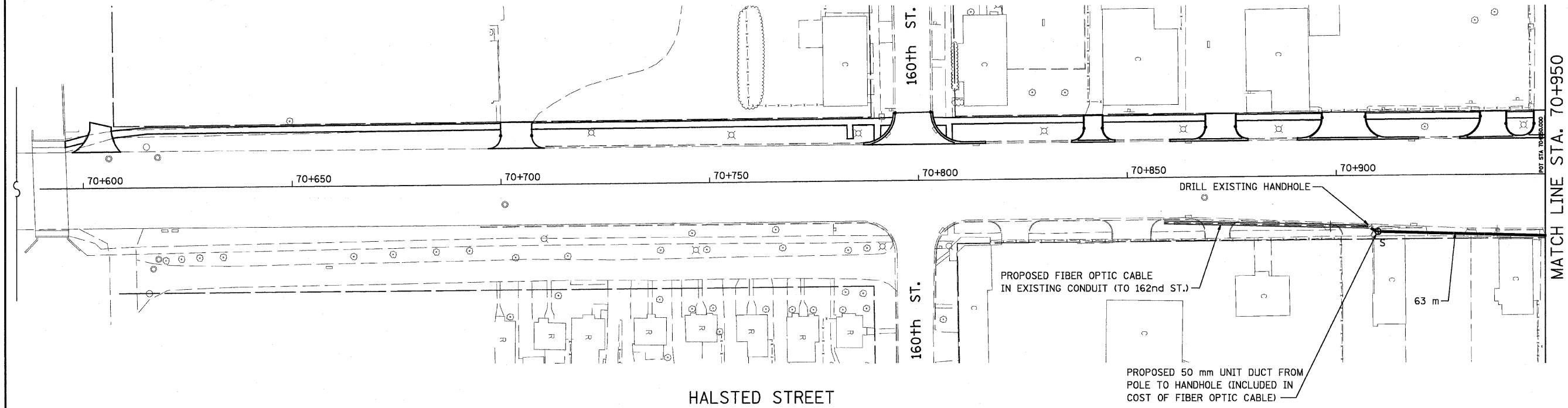

NOTE:
THE TRAFFIC SIGNAL CONTROLLER EQUIPMENT FOR THIS SYSTEM SHALL BE "ECONOLITE" TO MATCH THE EXISTING ADJACENT SYSTEM.

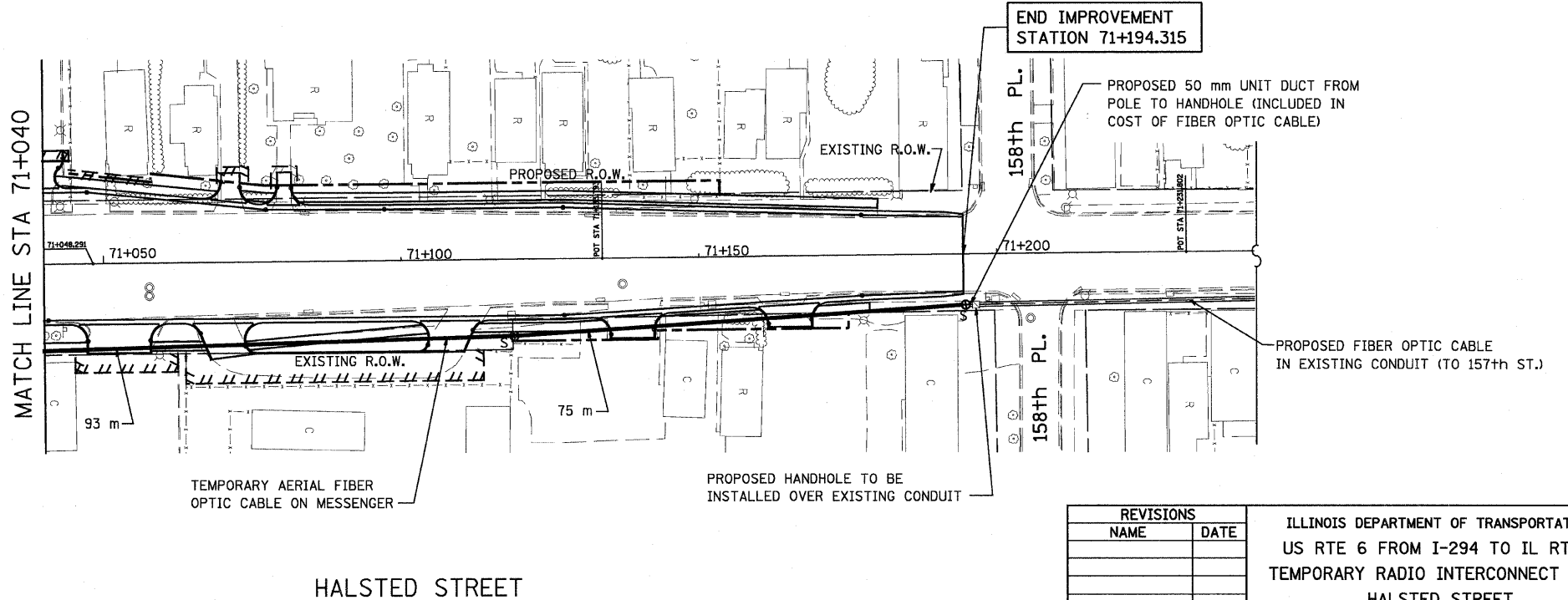

FOR LEGEND SEE SHEET NO. 306

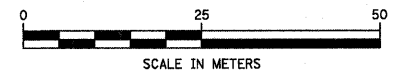

REVISIONS	
NAME	DATE

ILLINOIS DEPARTMENT OF TRANSPORTATION
US RTE 6 FROM I-294 TO IL RTE 1
TEMPORARY RADIO INTERCONNECT PLAN
HALSTED STREET
SHEET 5 OF 5
DESIGNED BY / DRAWN BY RAM
DATE 01/28/09 CHECKED BY DDL

F.A.P. RTE.	SECTION	COUNTY	TOTAL SHEETS	SHEET NO.
351	3277R	COOK	541	325
STA.		TO STA.		
FED. ROAD DIST. NO.		ILLINOIS FED. AID PROJECT		
CONTRACT NO. 60774				

SCHEDULE OF QUANTITIES





















CODE NO.	ITEM	UNIT	WEST OF	EAST OF	TOTAL
			CARSE AVE.	CARSE AVE.	
B1400100	HANDHOLE	EACH	10	3	13
X0325705	RE-OPTIMIZE TRAFFIC SIGNAL SYSTEM, LEVEL 2	EACH	1	1	2
M8100060	CONDUIT IN TRENCH, 50mm, GALVANIZED STEEL	METER	1407	407	1814
M8101050	CONDUIT PUSHED, 50mm, GALVANIZED STEEL	METER	309	96	405
M8170425	ELECTRIC CABLE IN CONDUIT (EPR-TYPE RHW) 1/C NO. 10	METER	3038	1554	4592
M8190200	TRENCH AND BACKFILL FOR ELECTRICAL WORK	METER	1407	407	1814
M8710070	FIBER OPTIC CABLE IN CONDUIT 24F NO. 62.5/125	METER	3038	1554	4592

NOTE:
THE TRAFFIC SIGNAL CONTROLLER EQUIPMENT FOR THIS SYSTEM SHALL BE "EAGLE" TO MATCH THE EXISTING ADJACENT SYSTEM.

PROJECT OMISSION
NOTE: CONDUIT, HANDHOLES AND THE CONTROLLER AT PARK AVENUE IN THIS AREA WERE PREVIOUSLY INSTALLED IN CONTRACT 60E10. CABLING TO COMPLETE THE INTERCONNECT SYSTEM (INCLUDING THIS SECTION) SHALL BE INSTALLED AS PART OF THIS CONTRACT. SEE NOTE 1.

NOTE:
THE TRAFFIC SIGNAL CONTROLLER EQUIPMENT FOR THIS SYSTEM SHALL BE "ECONOLITE" TO MATCH THE EXISTING ADJACENT SYSTEM.

INTERCONNECT SCHEMATIC LEGEND

- PROPOSED INTERSECTION CONTROLLER 
- EXISTING INTERSECTION CONTROLLER 
- PROPOSED MASTER CONTROLLER 
- EXISTING MASTER CONTROLLER 
- MASTER MASTER CONTROLLER 
- PROPOSED INTERSECTION & SAMPLING (SYSTEM) DETECTORS 
- EXISTING INTERSECTION & SAMPLING (SYSTEM) DETECTORS 
- INTERCONNECT CABLE - NO. 62.5/125 24F FIBER OPTIC CABLE 
- INTERCONNECT CABLE - NO. 18 3 PAIR TWISTED, SHIELDED 
- LOOP DETECTOR CABLE - 2/C TWISTED, SHIELDED 
- EXISTING INTERCONNECT CABLE - NO. 62.5/125 12F FIBER OPTIC CABLE 
- EXISTING INTERCONNECT CABLE - NO. 18 3 PAIR TWISTED, SHIELDED 
- EXISTING LOOP DETECTOR CABLE - 2/C TWISTED, SHIELDED 
- TELEPHONE CONNECTION 
- PROPOSED TRACER CABLE NO. 10 1C 
- EXISTING INTERSECTION LOOP DETECTORS AND PROPOSED SAMPLING (SYSTEM) DETECTORS 
- EXISTING TELEPHONE CONNECTION 
- EXISTING TRACER CABLE 1/C (AS SPECIFIED) 
- EXISTING SAMPLING (SYSTEM) DETECTORS 
- PROPOSED SAMPLING (SYSTEM) DETECTORS 
- EXISTING SAMPLING (SYSTEM) DETECTORS 

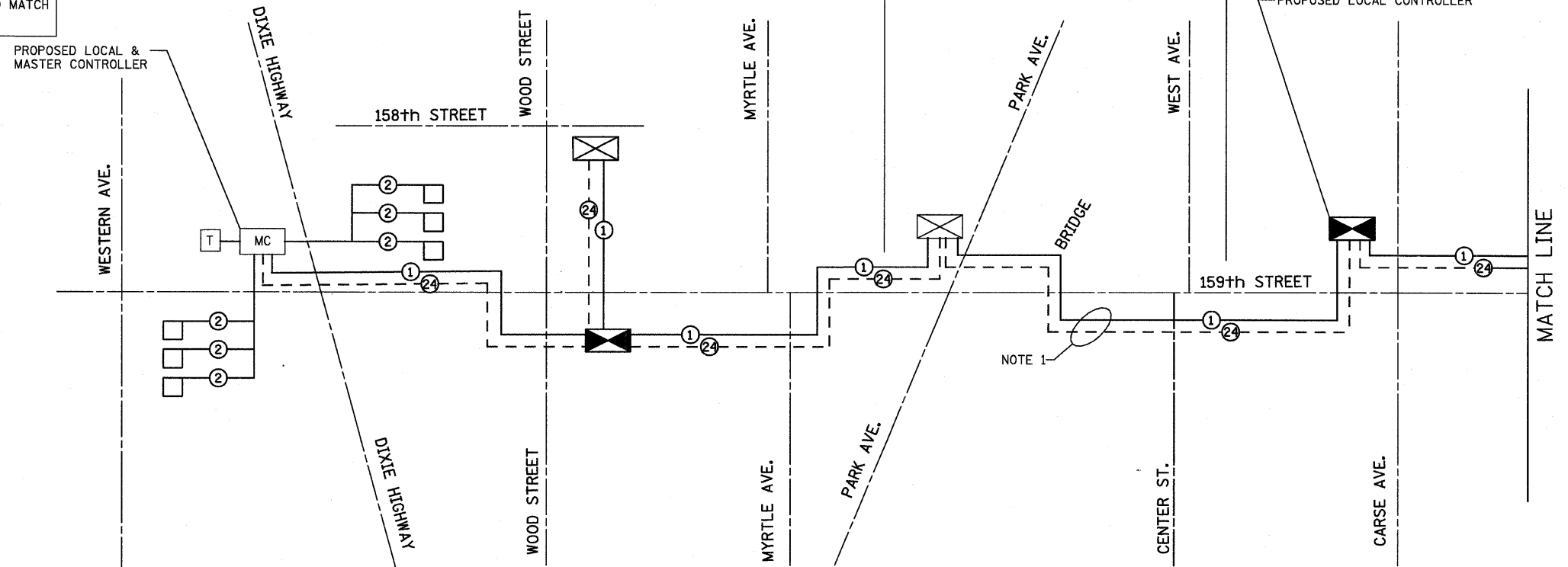

U.S. RTE. 6 (159TH / 162nd STREET)

NOTE 1: 24F CABLE WILL BE INSTALLED BETWEEN PARK AVE. AND CARSE AVE. OVER BRIDGE BUT NOT CONNECTED AT THE CONTROLLER.

REVISIONS	
NAME	DATE

F.A.P. RTE.	SECTION	COUNTY	TOTAL SHEETS	SHEET NO.
351	3277R	COOK	541	326
STA.		TO STA.		
FED. ROAD DIST. NO.		ILLINOIS FED. AID PROJECT		
CONTRACT NO. 60774				

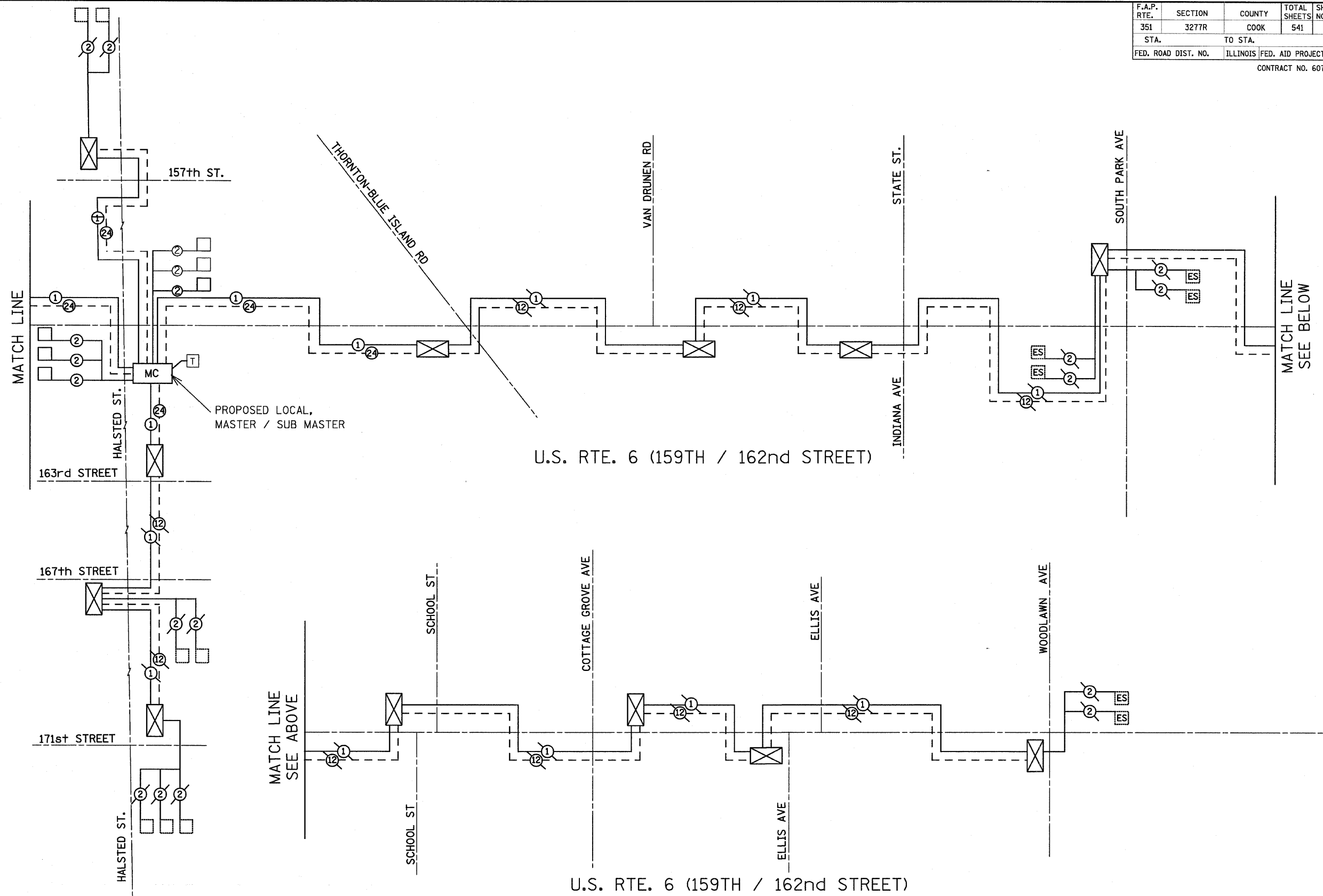

NOTE:
 THE TRAFFIC SIGNAL CONTROLLER EQUIPMENT FOR THIS SYSTEM SHALL BE "ECONOLITE" TO MATCH THE EXISTING ADJACENT SYSTEM.

FOR INTERCONNECT SCHEMATIC
 LEGEND SEE SHEET 311

REVISIONS	
NAME	DATE

ILLINOIS DEPARTMENT OF TRANSPORTATION
 US RTE 6 FROM I-294 TO IL RTE 1

INTERCONNECT SCHEMATIC

SCALE: NONE
 DATE 01/28/09

DRAWN BY RAM
 CHECKED BY DDL

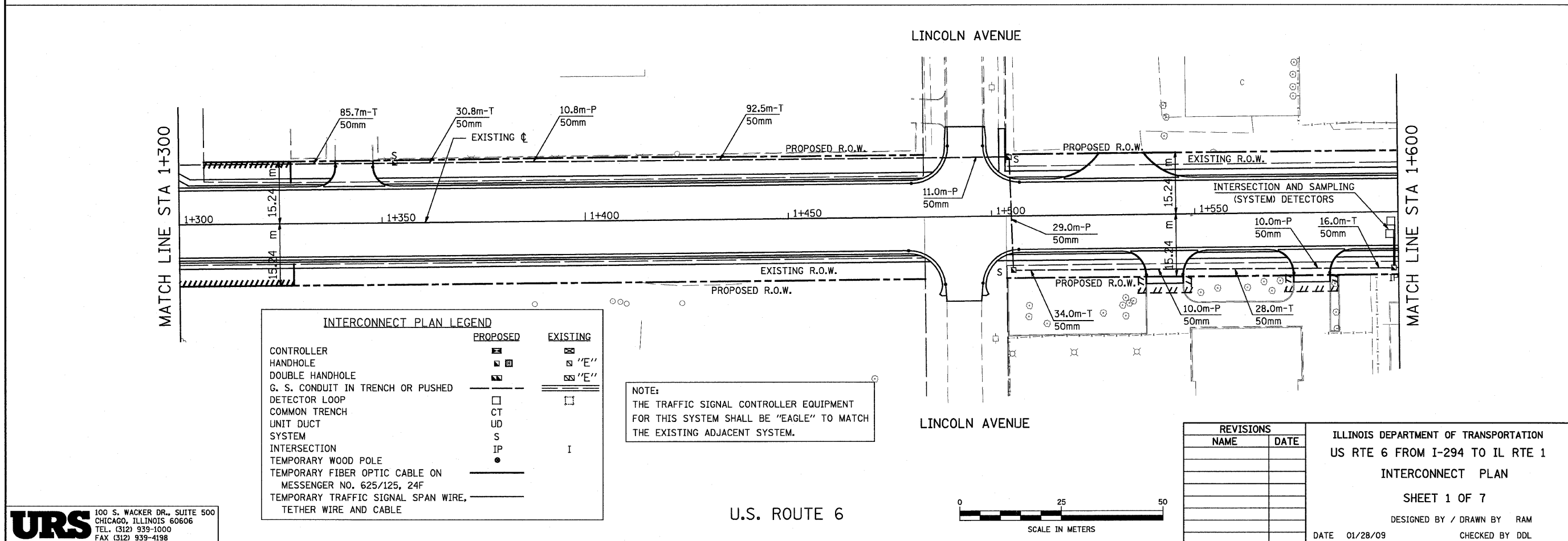
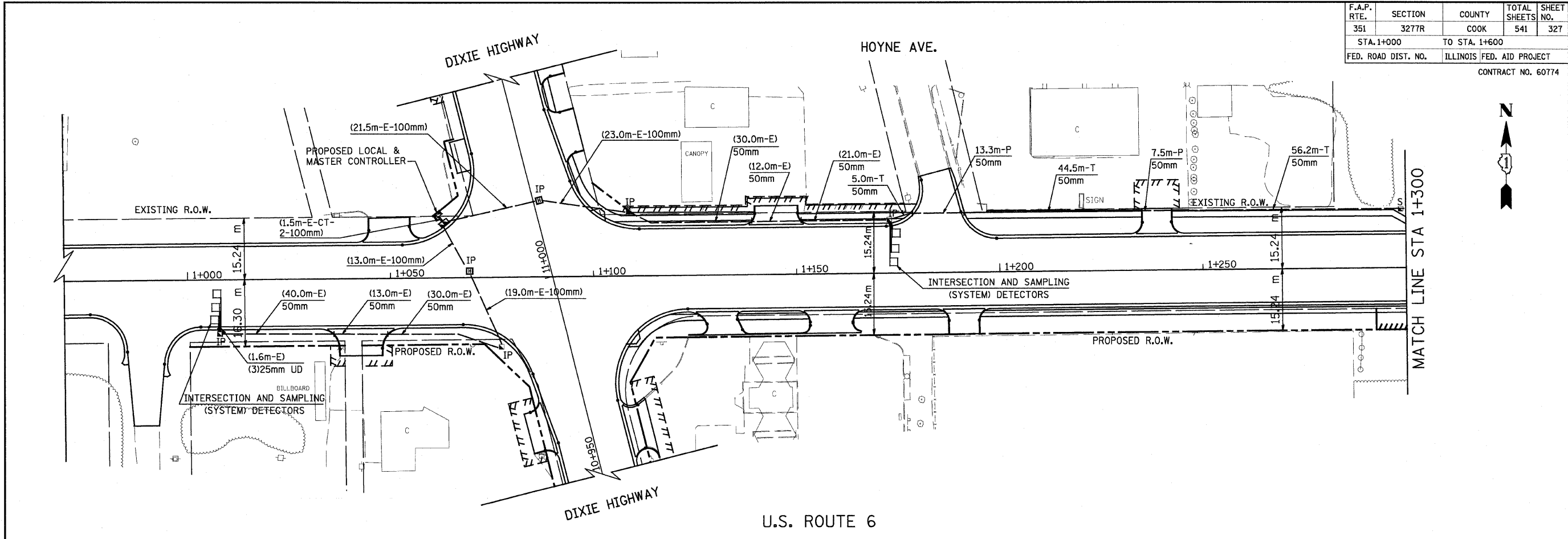

INTERCONNECT PLAN LEGEND

	PROPOSED	EXISTING
CONTROLLER	[Symbol]	[Symbol]
HANDHOLE	[Symbol]	[Symbol]
DOUBLE HANDHOLE	[Symbol]	[Symbol]
G. S. CONDUIT IN TRENCH OR PUSHED	[Symbol]	[Symbol]
DETECTOR LOOP	[Symbol]	[Symbol]
COMMON TRENCH	[Symbol]	[Symbol]
UNIT DUCT	[Symbol]	[Symbol]
SYSTEM	[Symbol]	[Symbol]
INTERSECTION	[Symbol]	[Symbol]
TEMPORARY WOOD POLE	[Symbol]	[Symbol]
TEMPORARY FIBER OPTIC CABLE ON MESSENGER NO. 625/125, 24F	[Symbol]	[Symbol]
TEMPORARY TRAFFIC SIGNAL SPAN WIRE, TETHER WIRE AND CABLE	[Symbol]	[Symbol]

NOTE:
THE TRAFFIC SIGNAL CONTROLLER EQUIPMENT FOR THIS SYSTEM SHALL BE "EAGLE" TO MATCH THE EXISTING ADJACENT SYSTEM.

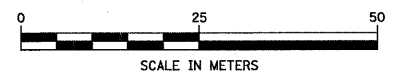

REVISIONS	
NAME	DATE

ILLINOIS DEPARTMENT OF TRANSPORTATION
US RTE 6 FROM I-294 TO IL RTE 1
INTERCONNECT PLAN
SHEET 1 OF 7
DESIGNED BY / DRAWN BY RAM
DATE 01/28/09 CHECKED BY DDL

F.A.P. RTE.	SECTION	COUNTY	TOTAL SHEETS	SHEET NO.
351	327TR	COOK	541	328
STA. 1+600		TO STA. 2+150		
FED. ROAD DIST. NO.		ILLINOIS FED. AID PROJECT		

CONTRACT NO. 60774

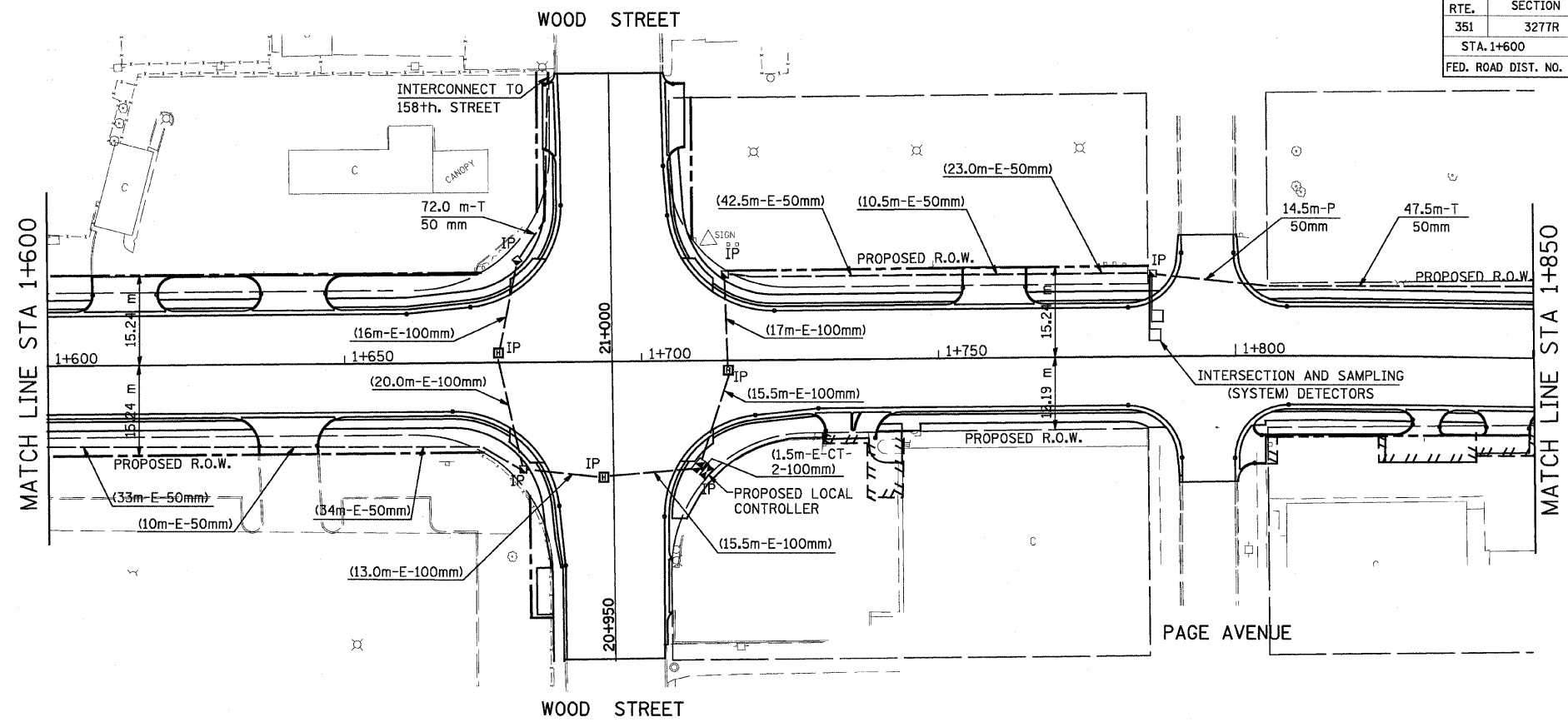

NOTE:
THE TRAFFIC SIGNAL CONTROLLER EQUIPMENT FOR THIS SYSTEM SHALL BE "EAGLE" TO MATCH THE EXISTING ADJACENT SYSTEM.

U.S. ROUTE 6

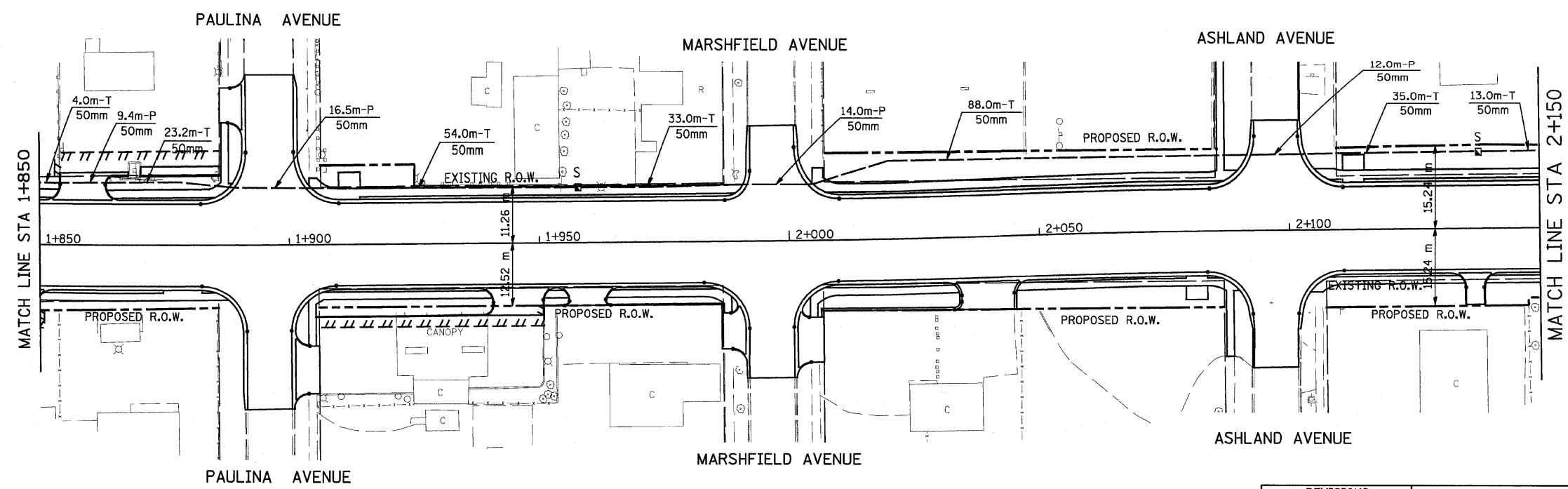

NOTE:
SEE INTERCONNECT PLAN SHEET 1 OF 7 FOR LEGEND

U.S. ROUTE 6

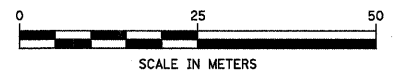

REVISIONS	
NAME	DATE

ILLINOIS DEPARTMENT OF TRANSPORTATION
US RTE 6 FROM I-294 TO IL RTE 1

INTERCONNECT PLAN
SHEET 2 OF 7

DESIGNED BY / DRAWN BY RAM
DATE 01/28/09 CHECKED BY DDL

URS 100 S. WACKER DR., SUITE 500
CHICAGO, ILLINOIS 60606
TEL. (312) 939-1000
FAX (312) 939-4198

F.A.P. RTE.	SECTION	COUNTY	TOTAL SHEETS	SHEET NO.
351	3277R	COOK	541	329
STA. 2+150		TO STA. 2+700		
FED. ROAD DIST. NO.	ILLINOIS	FED. AID PROJECT		
CONTRACT NO. 60774				

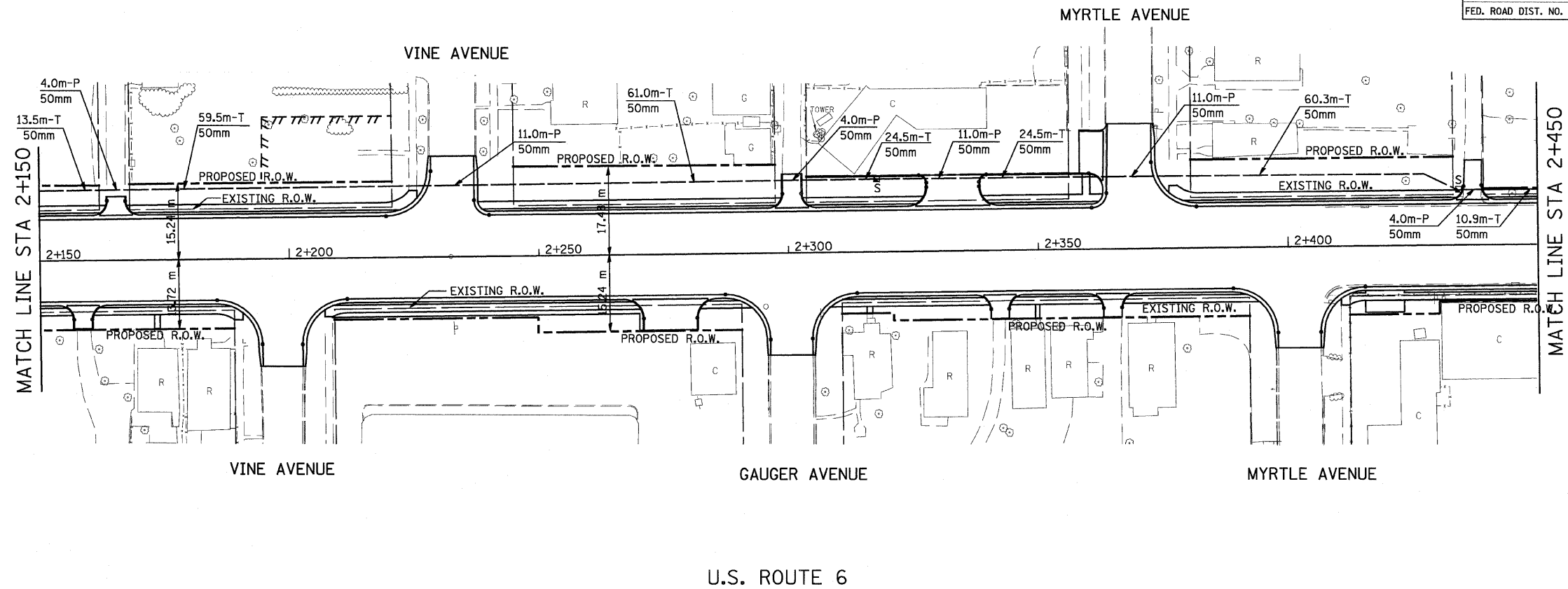

NOTE:
THE TRAFFIC SIGNAL CONTROLLER EQUIPMENT FOR THIS SYSTEM SHALL BE "EAGLE" TO MATCH THE EXISTING ADJACENT SYSTEM.

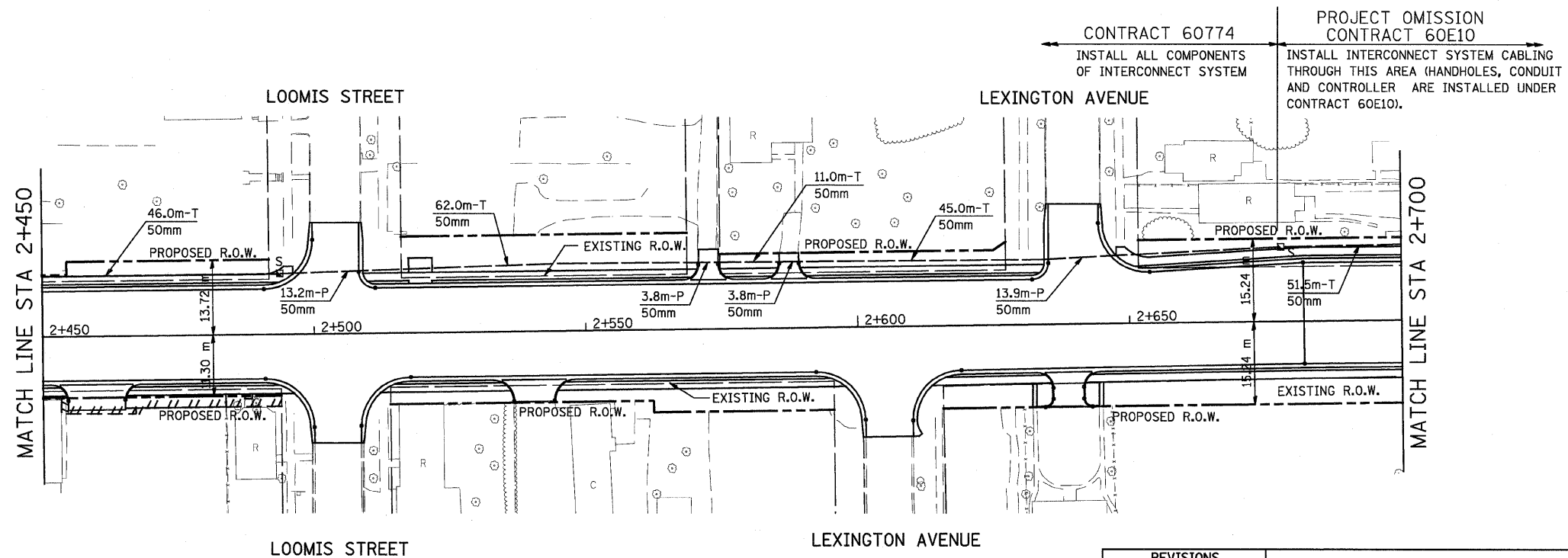

NOTE:
SEE INTERCONNECT PLAN SHEET 1 OF 7 FOR LEGEND

URS
100 S. WACKER DR., SUITE 500
CHICAGO, ILLINOIS 60606
TEL. (312) 939-1000
FAX (312) 939-4198

U.S. ROUTE 6

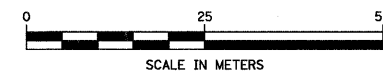

REVISIONS	
NAME	DATE

ILLINOIS DEPARTMENT OF TRANSPORTATION
US RTE 6 FROM I-294 TO IL RTE 1

INTERCONNECT PLAN
SHEET 3 OF 7
DESIGNED BY / DRAWN BY RAM
DATE 01/28/09 CHECKED BY DDL

F.A.P. RTE.	SECTION	COUNTY	TOTAL SHEETS	SHEET NO.
351	3277R	COOK	541	330
STA. 2+700		TO STA. 3+250		
FED. ROAD DIST. NO.		ILLINOIS FED. AID PROJECT		
CONTRACT NO. 60774				

PROJECT OMISSION
CONTRACT 60E10
INSTALL INTERCONNECT SYSTEM CABLING THROUGH THIS AREA (HANDHOLES, CONDUIT AND CONTROLLER ARE INSTALLED UNDER CONTRACT 60E10).

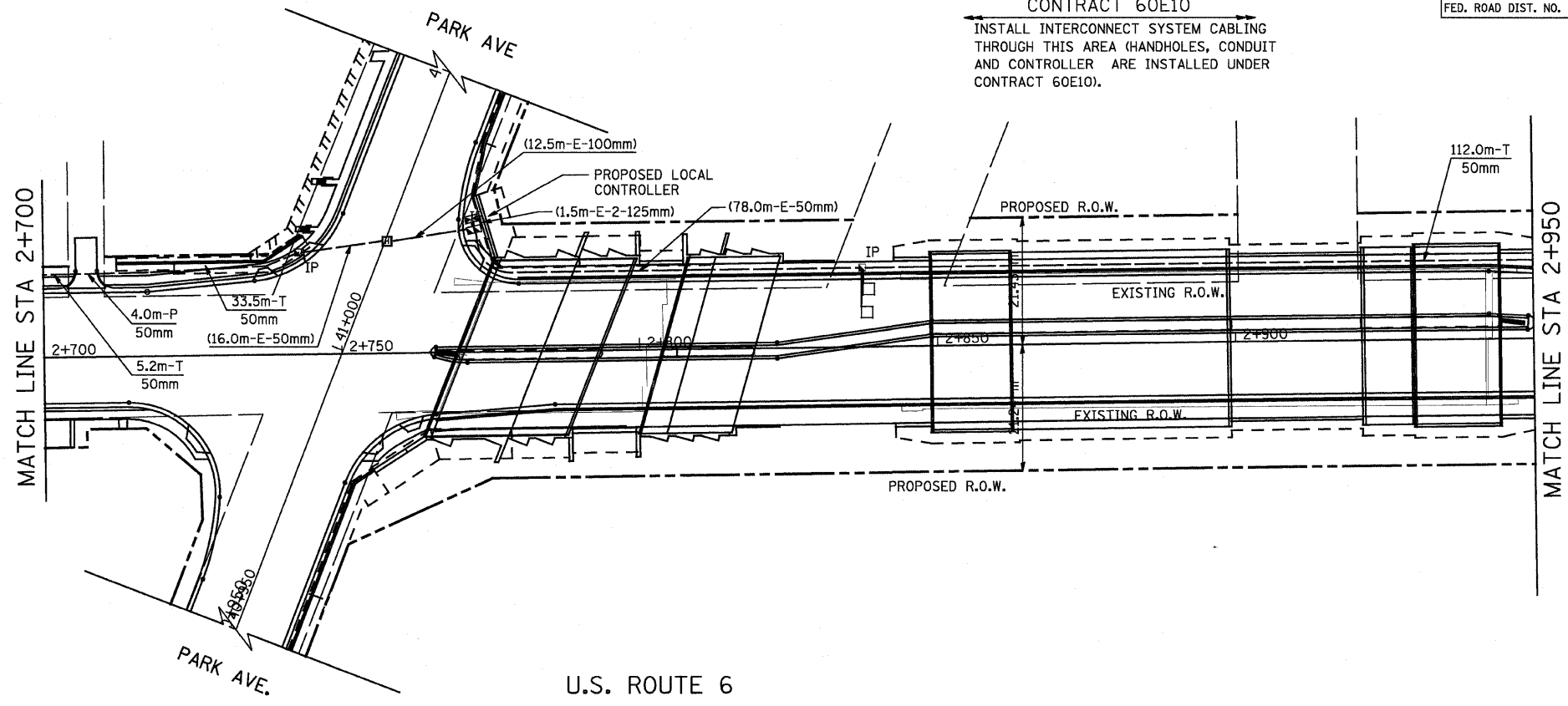

NOTE:
THE TRAFFIC SIGNAL CONTROLLER EQUIPMENT FOR THIS SYSTEM SHALL BE "EAGLE" TO MATCH THE EXISTING ADJACENT SYSTEM.

U.S. ROUTE 6

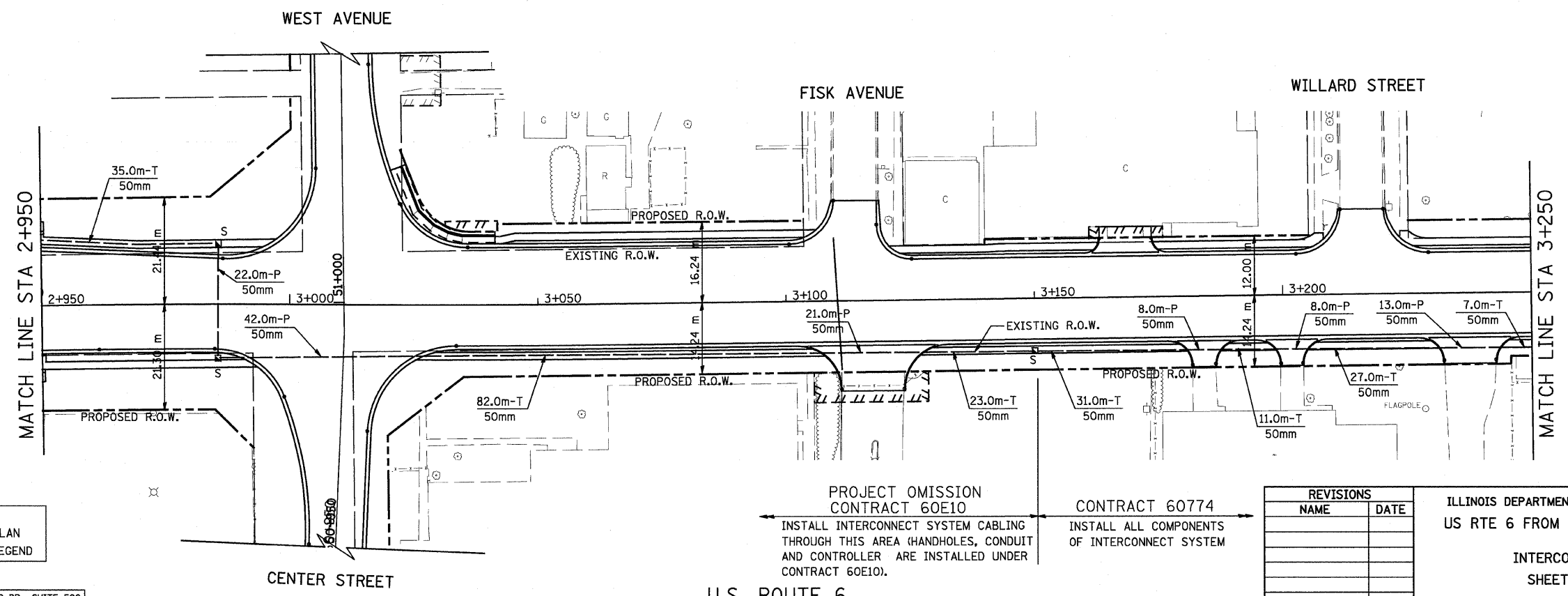

NOTE:
SEE INTERCONNECT PLAN SHEET 1 OF 7 FOR LEGEND

PROJECT OMISSION
CONTRACT 60E10
INSTALL INTERCONNECT SYSTEM CABLING THROUGH THIS AREA (HANDHOLES, CONDUIT AND CONTROLLER ARE INSTALLED UNDER CONTRACT 60E10).

CONTRACT 60774
INSTALL ALL COMPONENTS OF INTERCONNECT SYSTEM

U.S. ROUTE 6

REVISIONS	
NAME	DATE

ILLINOIS DEPARTMENT OF TRANSPORTATION
US RTE 6 FROM I-294 TO IL RTE 1

INTERCONNECT PLAN
SHEET 4 OF 7

DESIGNED BY / DRAWN BY RAM
DATE 01/28/09 CHECKED BY DDL

F.A.P. RTE.	SECTION	COUNTY	TOTAL SHEETS	SHEET NO.
351	3277R	COOK	541	331
STA. 3+250		TO STA. 3+850		
FED. ROAD DIST. NO.		ILLINOIS FED. AID PROJECT		

CONTRACT NO. 60774

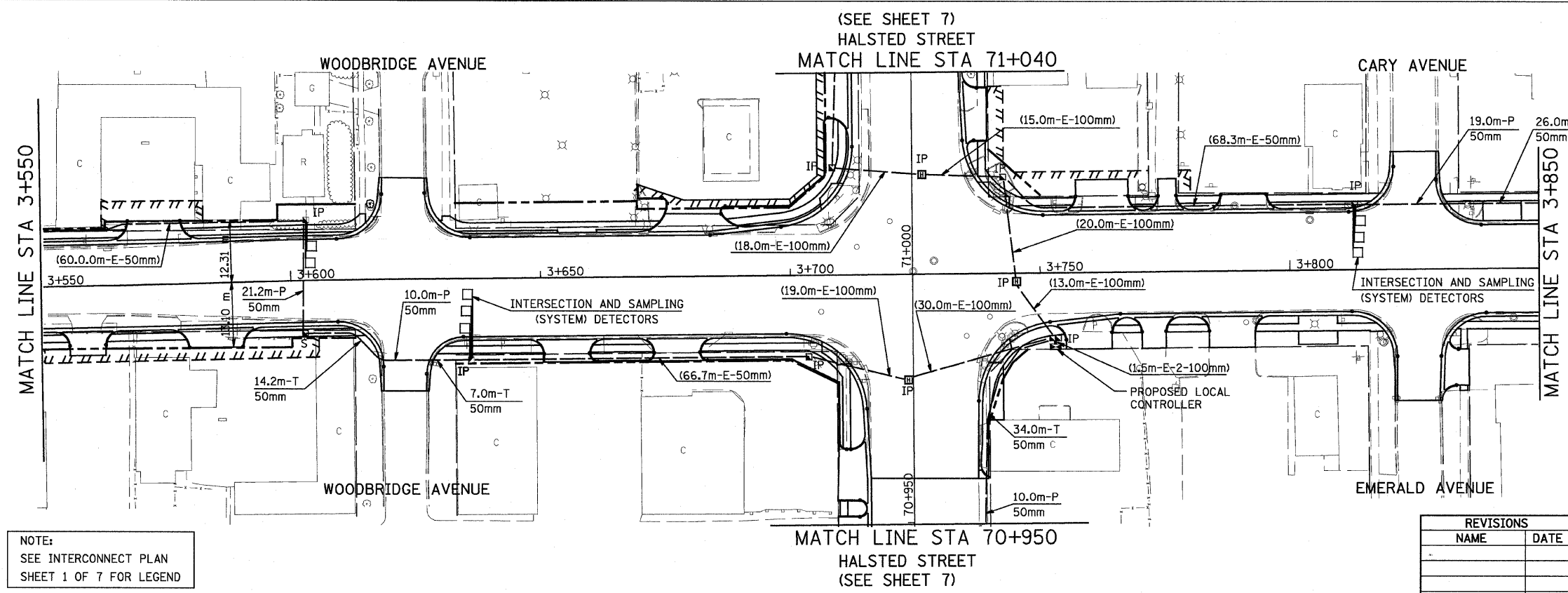
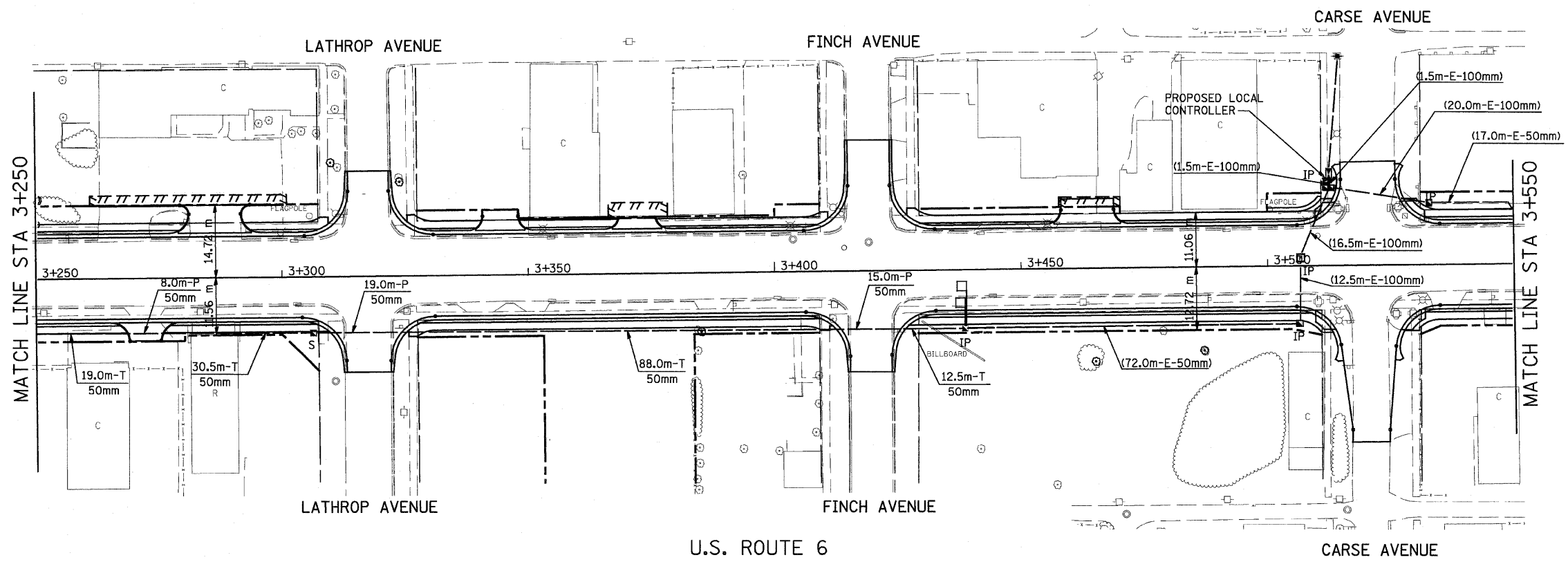

NOTE:
THE TRAFFIC SIGNAL CONTROLLER EQUIPMENT FOR THIS SYSTEM SHALL BE "ECONOLITE" TO MATCH THE EXISTING ADJACENT SYSTEM.

NOTE:
SEE INTERCONNECT PLAN SHEET 1 OF 7 FOR LEGEND

URS 100 S. WACKER DR., SUITE 500
CHICAGO, ILLINOIS 60606
TEL. (312) 939-1000
FAX (312) 939-4198

REVISIONS	
NAME	DATE

ILLINOIS DEPARTMENT OF TRANSPORTATION
US RTE 6 FROM I-294 TO IL RTE 1

INTERCONNECT PLAN
SHEET 5 OF 7
DESIGNED BY / DRAWN BY RAM
DATE 01/28/09 CHECKED BY DDL

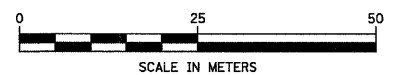

F.A.P. RTE.	SECTION	COUNTY	TOTAL SHEETS	SHEET NO.
351	3277R	COOK	541	332
STA. 3+850		TO STA. 3+973		
FED. ROAD DIST. NO.		ILLINOIS FED. AID PROJECT		

CONTRACT NO. 60774

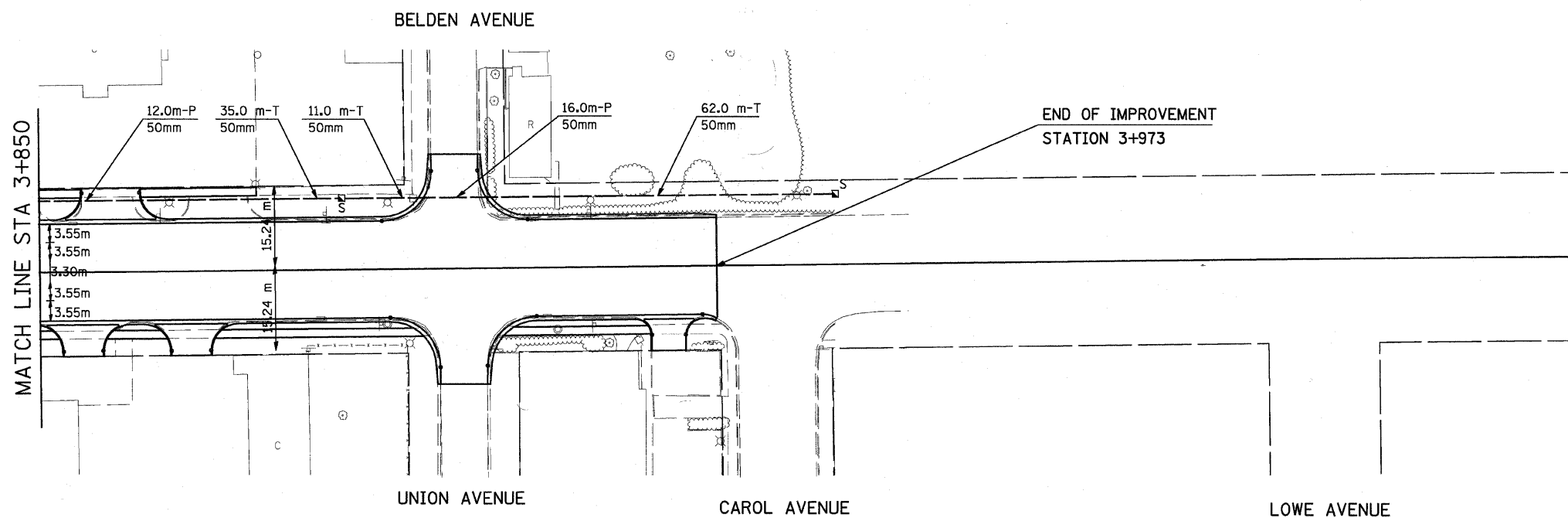

NOTE:
SEE INTERCONNECT PLAN
SHEET 1 OF 7 FOR LEGEND

U.S. ROUTE 6

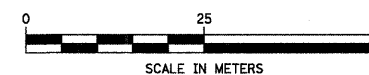

REVISIONS	
NAME	DATE

ILLINOIS DEPARTMENT OF TRANSPORTATION
US RTE 6 FROM I-294 TO IL RTE 1

INTERCONNECT PLAN
SHEET 6 OF 7

DESIGNED BY / DRAWN BY RAM
DATE 01/28/09 CHECKED BY DDL

URS 100 S. WACKER DR., SUITE 500
CHICAGO, ILLINOIS 60606
TEL. (312) 939-1000
FAX (312) 939-4198

F.A.P. RTE.	SECTION	COUNTY	TOTAL SHEETS	SHEET NO.
351	3277R	COOK	541	333
STA. 70+900		TO STA. 71+200		
FED. ROAD DIST. NO.		ILLINOIS FED. AID PROJECT		

CONTRACT NO. 60774

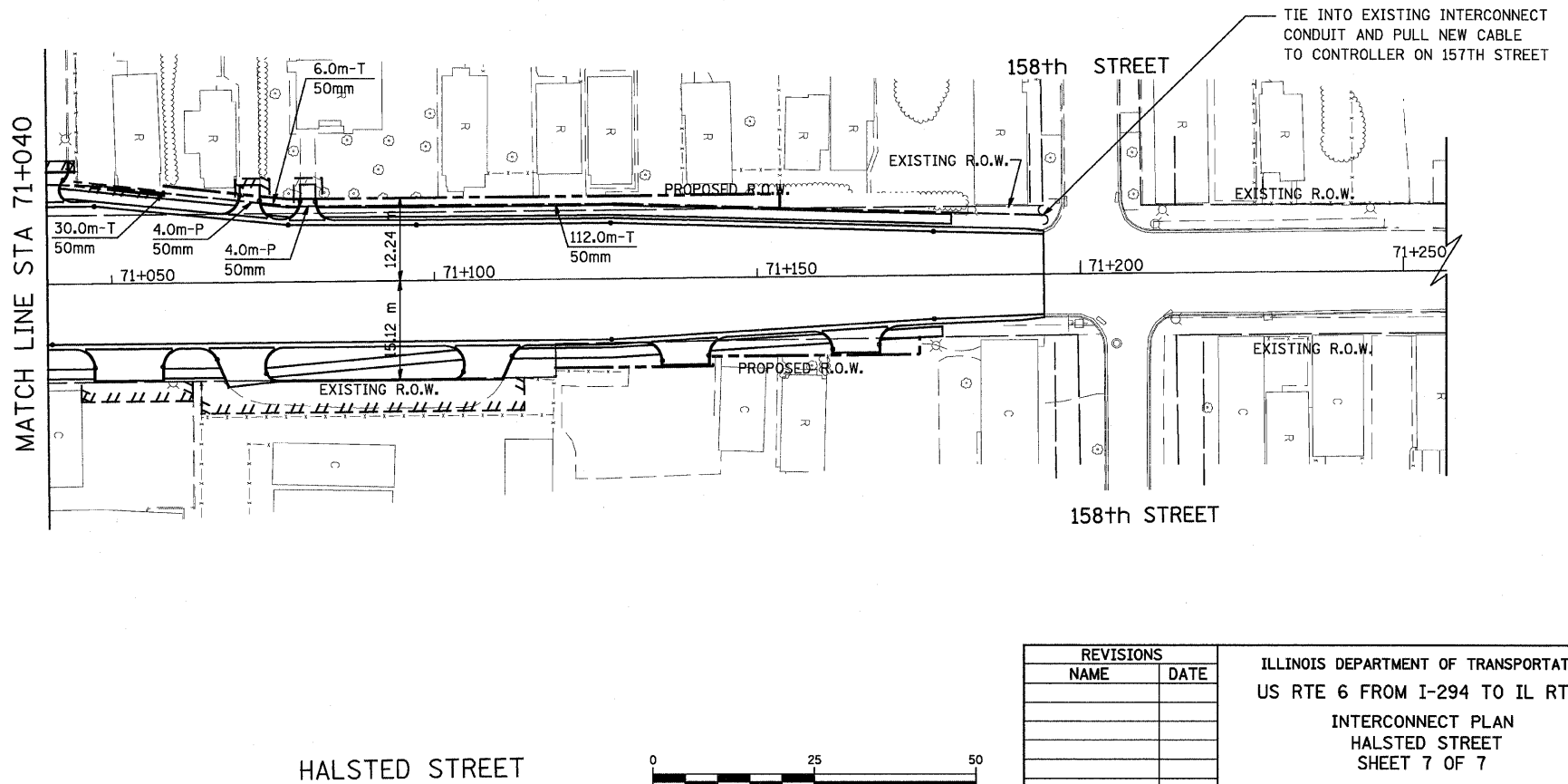
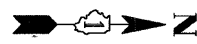
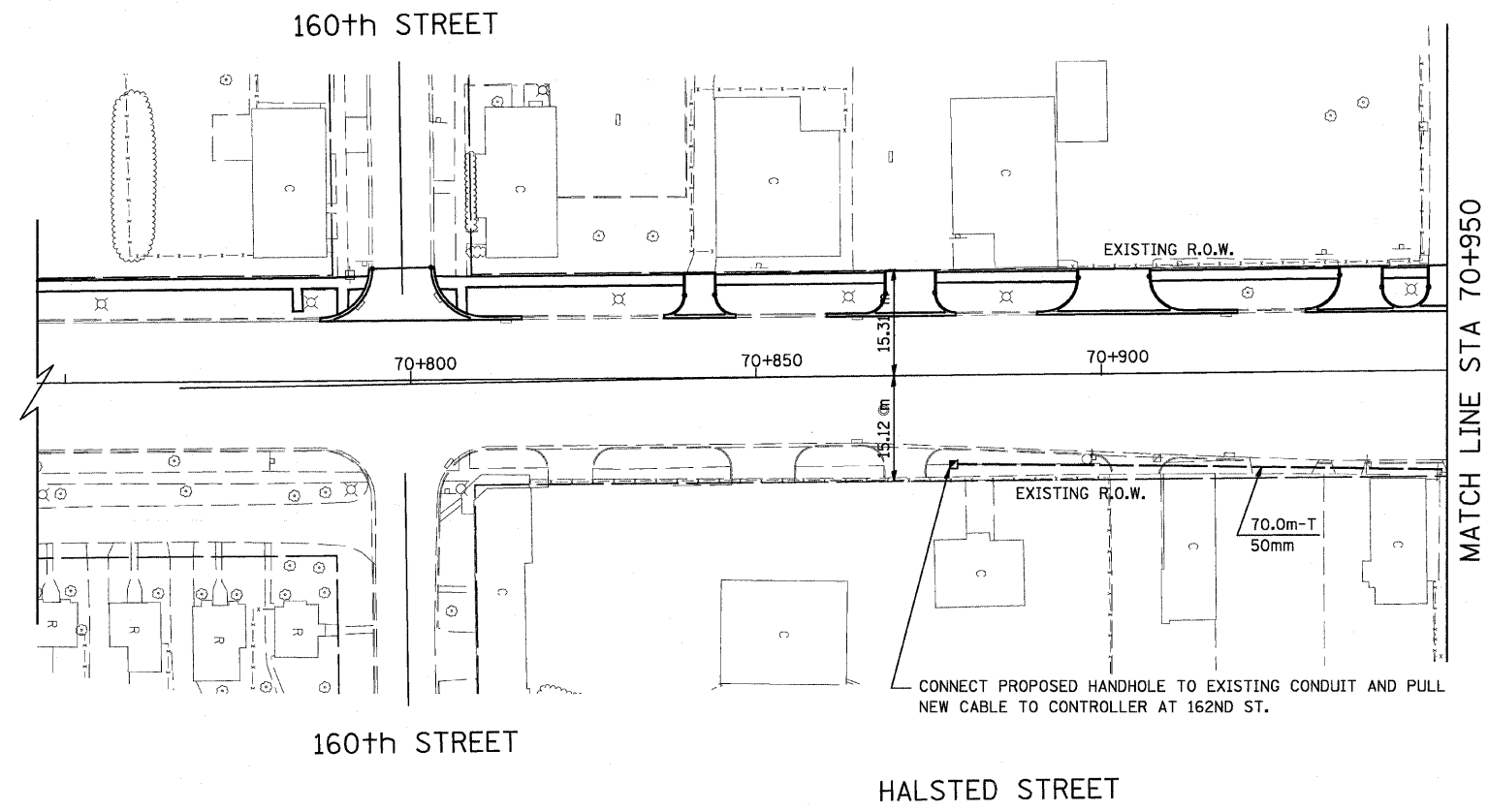

NOTE:
SEE INTERCONNECT PLAN
SHEET 1 OF 7 FOR LEGEND

URS 100 S. WACKER DR., SUITE 500
CHICAGO, ILLINOIS 60606
TEL. (312) 939-1000
FAX (312) 939-4198

HALSTED STREET

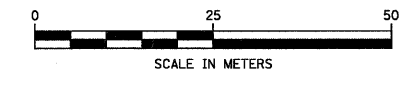

REVISIONS	
NAME	DATE

ILLINOIS DEPARTMENT OF TRANSPORTATION
US RTE 6 FROM I-294 TO IL RTE 1
INTERCONNECT PLAN
HALSTED STREET
SHEET 7 OF 7
DATE 01/28/09
DRAWN BY AK
CHECKED BY DDL

GENERAL NOTES

1. CONTRACTOR TO CONNECT AERIAL CABLE TO EXISTING LIGHTING CONTROLLER AND RUN UP WOOD SUPPORT POLE, EXTEND TO WOOD LIGHT POLES SHOWN TO FEED TEMPORARY STREET LIGHTS EAST AND WEST.
2. CONTRACTOR SHALL MAINTAIN POWER TO EXISTING LIGHT POLES DESIGNATED AS 'E' UNTIL COMPLETION OF CONSTRUCTION PHASE I, FROM EXISTING LIGHTING CONTROLLERS UNLESS NOTED OTHERWISE INDICATED ON PLANS.
3. CONTRACTOR SHALL DISCONNECT EXISTING CIRCUITS SERVING LIGHT POLES DESIGNATED AS "R" FROM EXISTING CONTROLLER.
4. USE THE AVAILABLE CIRCUITS IN EXISTING CONTROLLERS TO FEED TEMPORARY ROADWAY LIGHTS. CONNECT LIGHTS TO ALTERNATE PHASES. I.e. L1-N, L2-N.
5. CONTRACTOR SHALL REMOVE EXISTING MAST ARMS AND LUMINAIRES DESIGNATED AS $\text{\textcircled{R}}$ THESE FIXTURES ARE PART OF THE VILLAGE SYSTEM AND SHOULD BE RETURNED TO THE VILLAGE.
6. CONTRACTOR SHALL COORDINATE THE LOCATIONS OF WOOD LIGHT POLES WITH THE PROPOSED POLE LOCATIONS SUCH THAT REMOVAL/RELOCATION OF THE TEMPORARY INSTALLATION IS NOT REQUIRED AT THE TIME OF PROPOSED POLE INSTALLATION.
7. ALL THE ALUMINUM LIGHT POLES SHOULD BE PROVIDED WITH LUMINAIRE SAFETY CABLE ASSEMBLY.
8. CONTRACTOR SHALL USE EXISTING POLES TO SUPPORT TEMPORARY AERIAL CABLE.
9. THE CONTRACTOR SHALL BE RESPONSIBLE FOR THE MAINTENANCE OF ALL TEMPORARY LIGHTING WITHIN THE PROJECT LIMITS FOR THE ENTIRE DURATION OF THE PROJECT. ANY DAMAGE INCURRED DURING CONSTRUCTION SHALL BE PROMPTLY REPAIRED SO SERVICE IS NOT DISRUPTED. CONTRACTOR IS RESPONSIBLE FOR VERIFYING THE EXISTING CONDITIONS.
10. LOCATIONS OF WOOD LIGHT POLES SHALL BE APPROVED BY THE ENGINEER PRIOR TO INSTALLATION.
11. RELOCATION OF THE EXISTING LIGHTING CONTROLLER, IF REQUIRED SHALL BE ACCOMPLISHED IN ONE DAY SO THAT LIGHTING FOR THE INTERSECTION IS NOT INTERRUPTED. ALL AERIAL WIRING AND SERVICE CONNECTIONS SHALL BE IN-PLACE PRIOR TO ACTUAL RELOCATION OF THE CONTROLLER.
12. TEMPORARY LIGHTING WHICH WILL NOT REMAIN UPON PROJECT COMPLETION SHALL BE REMOVED ONCE THE PERMANENT LIGHTING IS INSTALLED AND OPERATIONAL. REMOVAL OF THE AERIAL CABLE AND TEMPORARY WOOD POLE SHALL BE PAID FOR AS "REMOVAL OF TEMPORARY LIGHTING UNITS". REMOVAL OF THE EXISTING LIGHTING POLES AND LUMINAIRES SHALL BE PAID FOR AS "REMOVAL OF EXISTING LIGHTING UNIT, SALVAGE". SEE PLAN SHEETS FOR SPECIFIC LIGHTING STATUS. CONTRACTOR SHALL ALSO REMOVE ALL NON-PERMANENT LIGHTING FACILITIES REMAINING FROM CONTRACT 60E10 AS PART OF THIS CONTRACT.
13. SETBACKS FOR POLES SHALL BE FROM THE BACK OF CURB UNLESS OTHERWISE NOTED ON THE PLANS.
14. CONTRACTOR SHALL SPLICE AERIAL CABLE AT LOCATIONS INDICATED TO PERMIT INDICATED CIRCUIT TO BRANCH INTO SIDE STREET.
15. CONTRACTOR TO INTERCEPT THE CIRCUIT FROM THE LIGHTING CONTROLLER TO THE EXISTING LIGHTING POLE AND TERMINATE THE SAME ON THE NEW WOOD LIGHT POLE. IF THIS CABLE IS NOT LONG ENOUGH, INSTALL NEW CABLE FROM THE EXISTING CONTROLLER TO THE WOOD LIGHT POLE. REMOVE THE OLD CABLE AND DISPOSE OFF PER CONTRACTUAL REQUIREMENTS.
16. NOT USED.
17. UNLESS OTHERWISE NOTED, POWER CABLES TO THE EXISTING POLES SHALL BE FED FROM THE EXISTING LIGHTING CONTROLLER. CONTRACTOR TO VERIFY THE CIRCUITRY PRIOR TO MAKING ANY CHANGES.
18. NOT USED.
19. CONTRACTOR SHALL DISCONNECT THE POLE WIRES ONLY AT THE FUSES, LEAVING THE OTHER CIRCUITRY IN TACT TO ENSURE THAT CONTINUITY OF POWER TO THE SUCCEEDING AND PRECEDING POLES IS NOT DISRUPTED.
20. UNLESS NEW CABLE CONNECTIONS /MODIFICATIONS ARE SHOWN ON THE TEMPORARY LIGHTING PLANS, CONTRACTOR SHALL VERIFY THE EXISTING CIRCUITRY AND MAINTAIN CONTINUITY OF POWER FOR ALL THE EXISTING POLES.
21. IF THE EXISTING LIGHTING POLE IS FED FROM A CONTROLLER LOCATED ON A SIDE STREET, LEAVE THE CIRCUITRY "AS IS" FOR USE AS TEMPORARY LIGHTING FOR U.S. ROUTE 6.
22. AERIAL CABLE WHEN USED SHALL BE SECURELY ATTACHED TO EACH LIGHTING POLE. DRILLING INTO THE POLE WILL NOT BE PERMITTED. THE MOUNTING HEIGHT OF THE ATTACHMENT SHALL BE CONSISTENT WITH THE MOUNTING HEIGHT OF THE AERIAL CABLE ON THE TEMPORARY WOOD POLES. THE AERIAL CABLES COMING DOWN THE LIGHTING POLE TO THE EXISTING LIGHTING POLE SHALL BE SECURELY ATTACHED TO THE POLE AS DIRECTED BY THE ENGINEER. THIS WORK WILL NOT BE PAID FOR SEPARATELY BUT SHALL BE INCIDENTAL TO THE COST OF THE AERIAL CABLE.
23. REFER TO PLANS FOR LOCATIONS OF TEMPORARY SERVICE WOOD POLES AND TO SHEET 415 FOR DETAILING.

PAY ITEM LIST

US ROUTE 6 FROM I-294 TO HALSTED STREET
JOB NO. D-91-249-99

CODE NO.	PAY ITEM	UNIT	TOTAL QUANTITY
82500560	LIGHTING CONTROLLER TYPE CB-RCS 200AMP - 480VOLT	EACH	2
80400100	ELECTRIC SERVICE INSTALLATION	EACH	2
M8100060	CONDUIT IN TRENCH, 50MM DIA., GALVANIZED STEEL	METER	1315
M8100070	CONDUIT IN TRENCH, 65MM DIA., GALVANIZED STEEL	METER	224
M8101060	CONDUIT PUSHED, 65MM DIA., GALVANIZED STEEL	METER	68
M8160400	UNIT DUCT, WITH 3-1/C NO.4 AND 1/C NO.6 GROUND 600V (EPR-TYPE RHW), 30MM DIA. POLYETHYLENE	METER	1639
M8160415	UNIT DUCT, WITH 3-1/C NO.2 AND 1/C NO.4 GROUND 600V (EPR-TYPE RHW), 40MM DIA. POLYETHYLENE	METER	1123
MX816065	UNIT DUCT, WITH 3-1/C NO.6 AND 1/C NO.6 GROUND 600V (EPR-TYPE RHW), 25MM DIA. POLYETHYLENE	METER	6042
M8170485	ELECTRIC CABLE IN CONDUIT, 600V (EPR-TYPE RHW) 3-1/C NO. 10	METER	3000
M8170805	ELECTRIC CABLE IN CONDUIT, 600V (EPR-TYPE USE) 3-1/C NO. 2	METER	77
M8180120	AERIAL CABLE, 3-1/C NO. 2 WITH MESSENGER WIRE	METER	2528
M8190200	TRENCH AND BACKFILL FOR ELECTRICAL WORK	METER	8655
82102310	LUMINAIRE, SODIUM VAPOR, HORIZONTAL MOUNT, 310 WATT	EACH	162
82102400	LUMINAIRE, SODIUM VAPOR, HORIZONTAL MOUNT, 400 WATT	EACH	38
M8305020	LIGHT POLE, ALUMINUM, 14.5M M.H., 2.5M MAST ARM	EACH	134
M8307290	LIGHT POLE, WOOD, 15.24 METER, CLASS 4	EACH	2
M8307300	LIGHT POLE, WOOD, 15.24 METER, CLASS 4, WITH 4.5 METER MAST ARM	EACH	38
M8360100	LIGHT POLE FOUNDATION, 600MM DIAMETER	METER	536
M8380095	BREAKAWAY DEVICE, TRANSFORMER BASE 381MM BOLT CIRCLE	EACH	134
84100110	REMOVAL OF TEMPORARY LIGHTING UNITS	EACH	65
84200500	REMOVAL OF EXISTING LIGHTING UNIT, SALVAGE	EACH	70
X0323574	MAINTENANCE OF LIGHTING SYSTEM	CAL MO	18
X0324387	LUMINAIRE SAFETY CABLE ASSEMBLY	EACH	162
X8040400	ELECTRIC UTILITY SERVICE CONNECTION	EACH	2
X8950080	REMOVE EXISTING LIGHTING CONTROLLER	EACH	2
MX033724	GROUND ROD, 16MM DIA. X 3.0 M	EACH	144

F.A. RTE.	SECTION	COUNTY	TOTAL SHEETS	SHEET NO.
351	3277R	COOK	541	334
STA.		TO STA.		
FED. ROAD DIST. NO.		ILLINOIS	FED. AID PROJECT	
CONTRACT NO. 60774				

DRAWING No. E-1

REVISIONS		ILLINOIS DEPARTMENT OF TRANSPORTATION US RTE 6 FROM I-294 TO IL RTE 1 GENERAL NOTES & SUMMARY OF QUANTITY
NAME	DATE	
		DRAWN BY S.S./W.S. CHECKED BY C.K./H.S. DATE 01/28/09

F.A. RTE.	SECTION	COUNTY	TOTAL SHEETS	SHEET NO.
351	3277R	COOK	541	335
STA. 0+450		TO STA. 1+000		
FED. ROAD DIST. NO.		ILLINOIS FED. AID PROJECT		
CONTRACT NO. 60774				

LEGEND

- ⊖ (R) EXISTING LTG. POLE TO BE REMOVED
- ⊖ (E) EXISTING LTG. POLE TO REMAIN "AS IS" ON THE EXISTING CIRCUIT DURING CONSTRUCTION STAGE I ONLY, TO BE REMOVED DURING CONSTRUCTION STAGE II.
- ▭ EXISTING PAVEMENT, SHOULDER CURB & GUTTER TO BE REMOVED BY OTHERS
- AC-XX— TEMPORARY AERIAL CABLE 3-1/C NO. 2 ALUMINUM WIRE WITH STEEL MESSENGER WIRE XX-INDICATES LENGTH IN METERS
- ⊖ (A) LIGHT POLE, WOOD, WITH 4.5M MAST ARM AND 400W HPS LUMINAIRES DURING CONSTRUCTION STAGE I ONLY AND TO BE REMOVED DURING CONSTRUCTION STAGE II, SEE NOTE-6 ON SHEET E-1. LETTER DENOTES CIRCUIT IN EXISTING CONTROLLER.
- LIGHT POLE, WOOD, FOR SUPPORT OF TEMPORARY AERIAL CABLE DURING CONSTRUCTION STAGE I
- ⊖ (X) EXISTING CONTROLLER TO BE REMOVED AT COMPLETION OF PROJECT
- ▨ CONSTRUCTION STAGE-I
- ▩ TEMPORARY PAVEMENT WITH TEMP. C&G

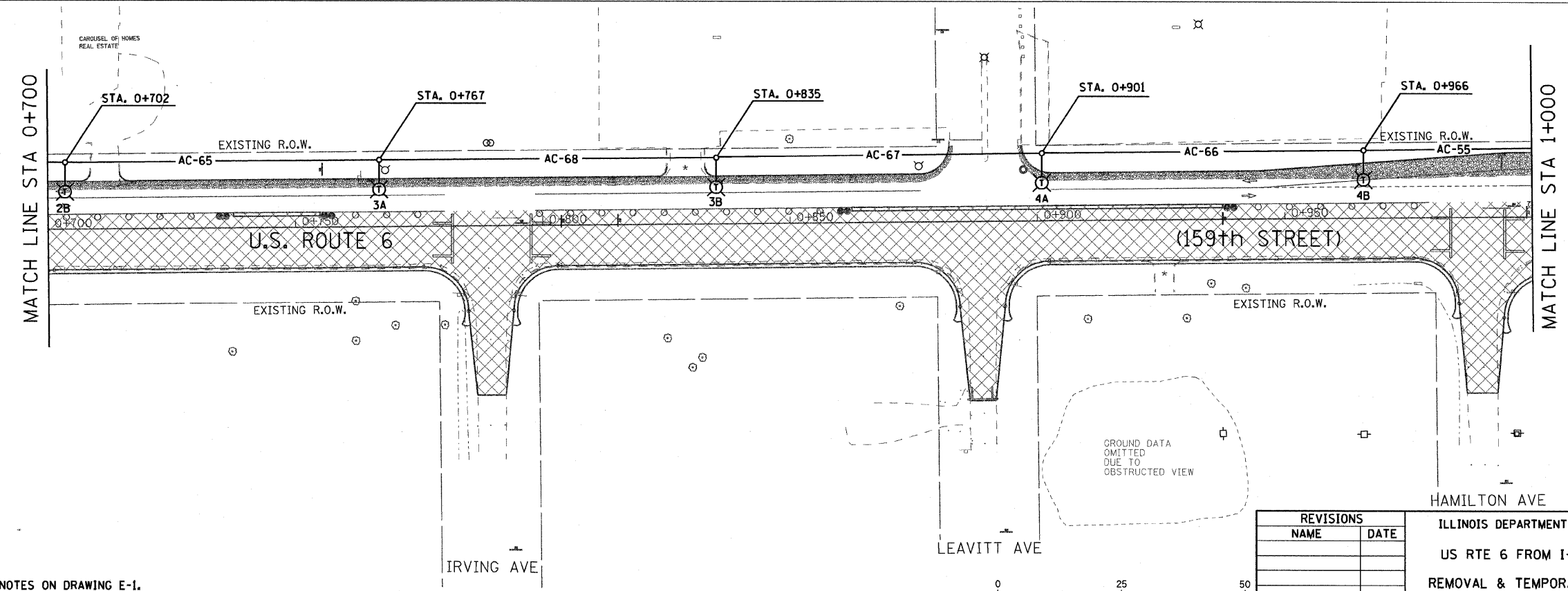
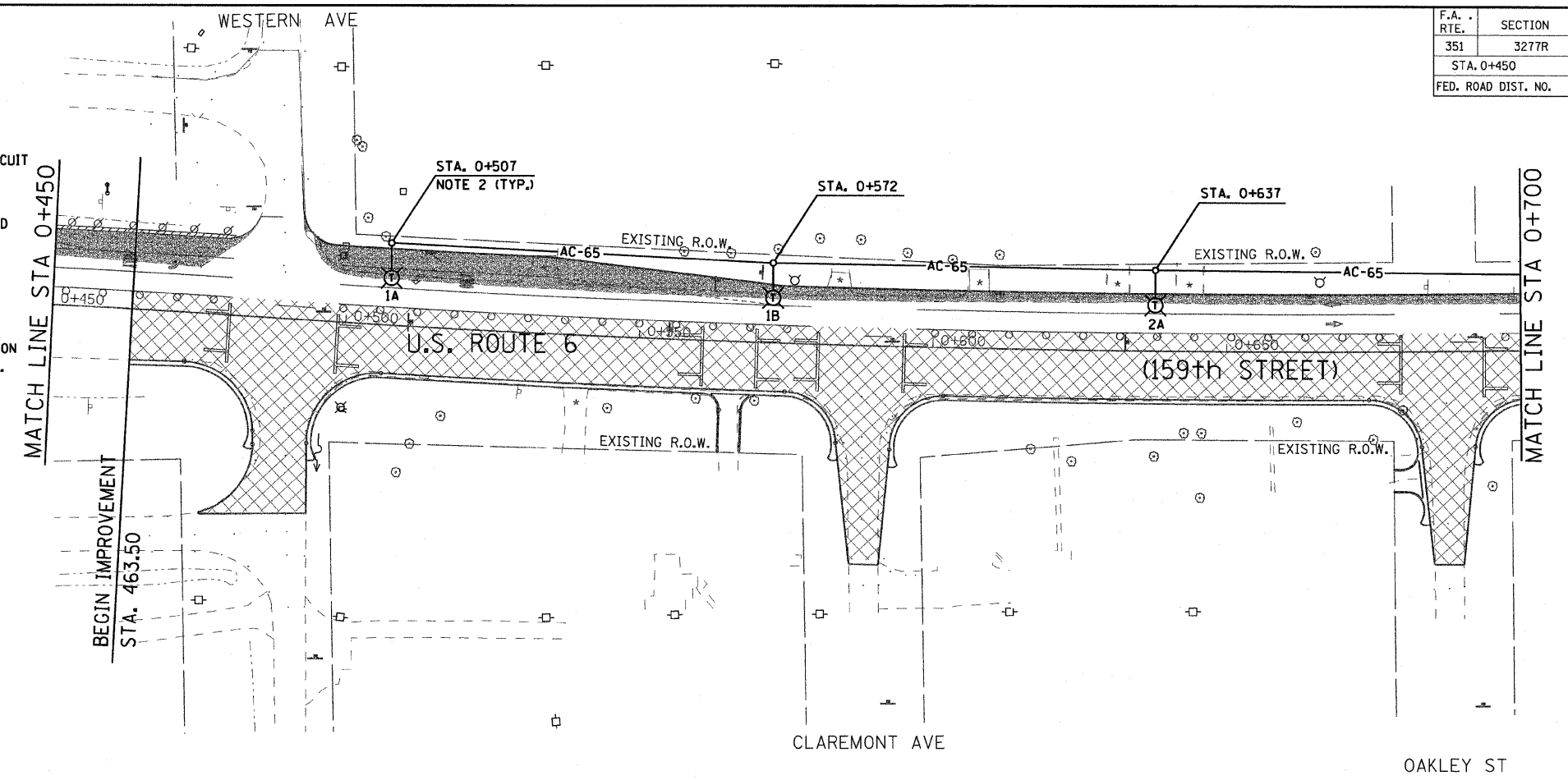

NOTES:

1. REFER TO LIGHTING NOTES ON DRAWING E-1.
2. SETBACK FOR THE TEMPORARY POLES SHALL BE 1.82 M (6') MINIMUM FROM THE BACK OF THE CURB.

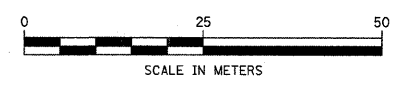

Delta Engineering, Inc.
CONSULTING ENGINEERS, CHICAGO, ILLINOIS

REVISIONS	
NAME	DATE









DRAWING No. E-2

ILLINOIS DEPARTMENT OF TRANSPORTATION
US RTE 6 FROM I-294 TO IL RTE 1
REMOVAL & TEMPORARY LIGHTING PLAN
FROM STA. 0+450 TO STA. 1+000

DATE 01/28/09
DRAWN BY S.S./W.S.
CHECKED BY C.K./H.S.

F.A. RTE.	SECTION	COUNTY	TOTAL SHEETS	SHEET NO.
351	3277R	COOK	541	336
STA. 1+000	TO STA. 1+600			
FED. ROAD DIST. NO.		ILLINOIS FED. AID PROJECT		
CONTRACT NO. 60774				

LEGEND

-  EXISTING LTG. POLE TO BE REMOVED
-  EXISTING LTG. POLE TO REMAIN "AS IS" ON THE EXISTING CIRCUIT DURING CONSTRUCTION STAGE I ONLY. TO BE REMOVED DURING CONSTRUCTION STAGE II
-  EXISTING PAVEMENT, SHOULDER CURB & GUTTER TO BE REMOVED BY OTHERS
-  TEMPORARY AERIAL CABLE 3-1/8 NO. 2 ALUMINUM WITH STEEL MESSENGER WIRE XX-INDICATES LENGTH IN METERS
-  LIGHT POLE, WOOD, WITH 4.5M MAST ARM AND 400W HPS LUMINAIRES DURING CONSTRUCTION STAGE I ONLY AND TO BE REMOVED DURING CONSTRUCTION STAGE II, SEE NOTE-6 ON SHEET E-1. LETTER DENOTES CIRCUIT IN EXISTING CONTROLLER.
-  LIGHT POLE, WOOD, FOR SUPPORT OF TEMPORARY AERIAL CABLE DURING CONSTRUCTION STAGE I
-  EXISTING CONTROLLER TO BE REMOVED AT COMPLETION OF PROJECT
-  CONSTRUCTION STAGE I.
-  TEMPORARY PAVEMENT WITH TEMP. C&C

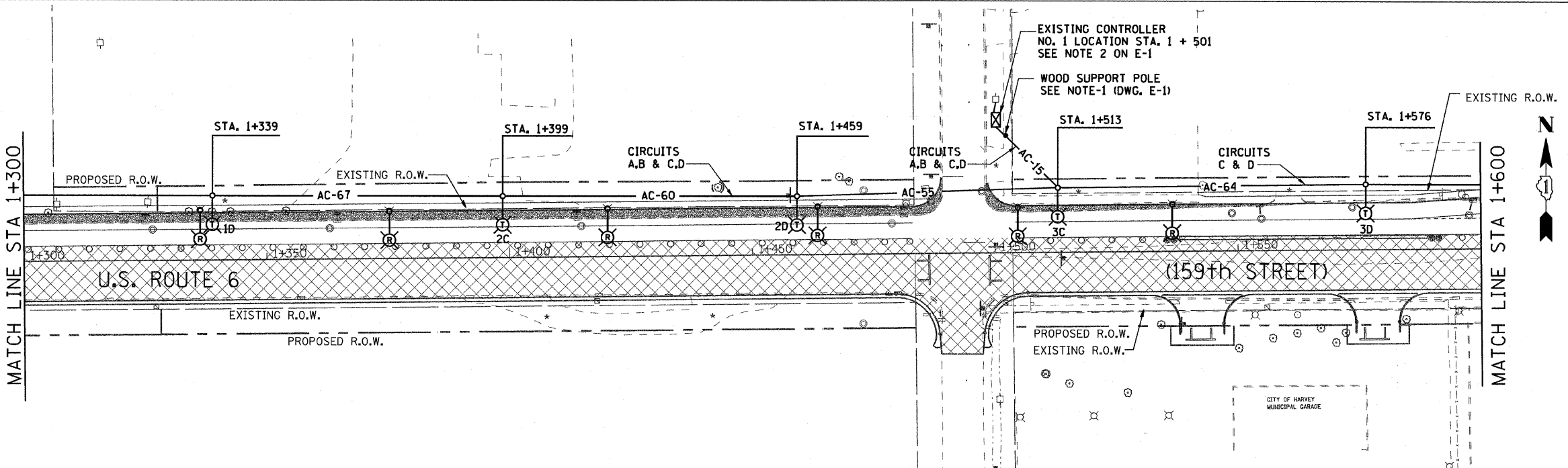
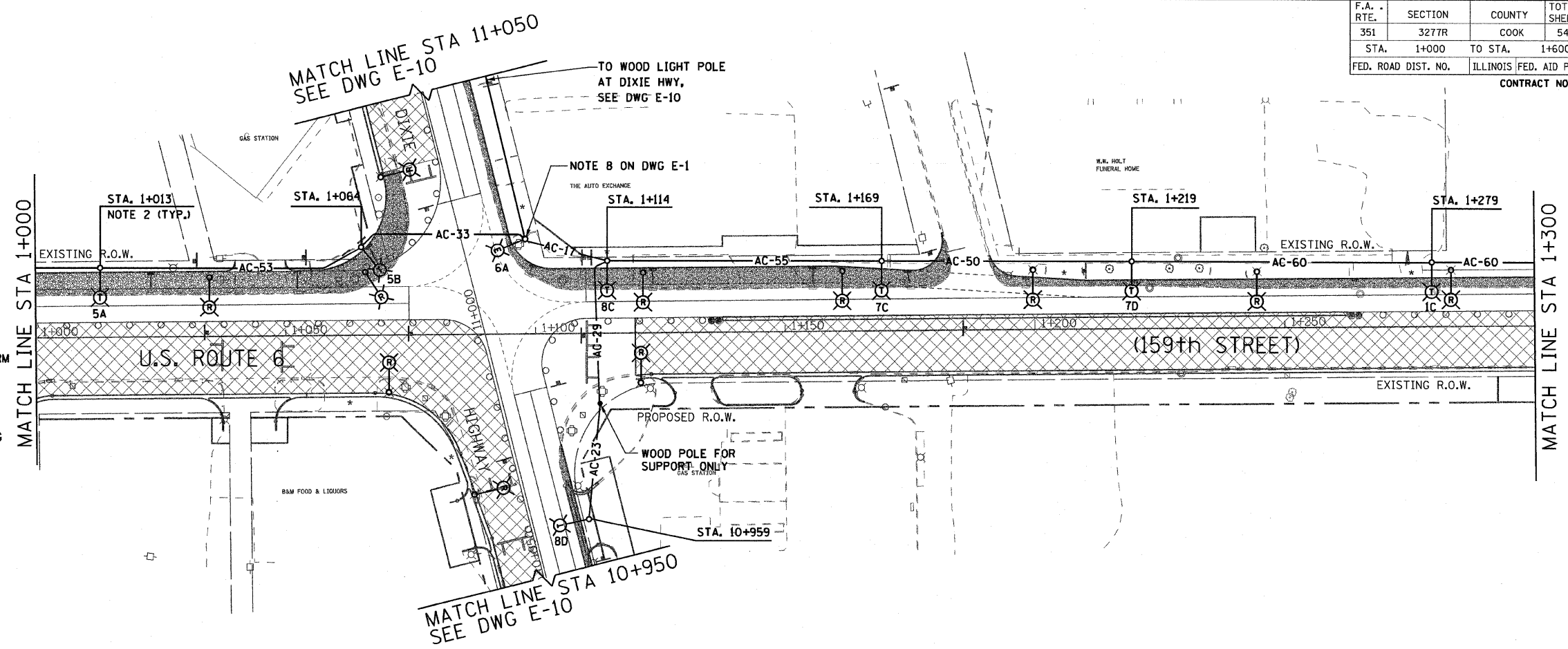

NOTES:

1. REFER TO LIGHTING NOTES ON DRAWING E-1.
2. SETBACK FOR THE TEMPORARY POLES SHALL BE 1.82 M (6') MINIMUM FROM THE BACK OF THE CURB.

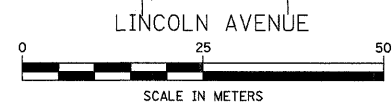

Lincoln Avenue
 Delta Engineering, Inc.
 CONSULTING ENGINEERS, CHICAGO, ILLINOIS

REVISIONS	
NAME	DATE

ILLINOIS DEPARTMENT OF TRANSPORTATION
 US RTE 6 FROM I-294 TO IL RTE 1
 REMOVAL & TEMPORARY LIGHTING PLAN
 FROM STA. 1+000 TO STA. 1+600
 DRAWN BY S.S./W.S.
 CHECKED BY C.K./H.S.
 DATE 01/28/09

DRAWING No. E-3

F.A. RTE.	SECTION	COUNTY	TOTAL SHEETS	SHEET NO.
351	3277R	COOK	541	337
STA. 1+600		TO STA. 2+150		
ILLINOIS FED. AID PROJECT		CONTRACT NO. 60774		

LEGEND

- ⊖ (R) EXISTING LTG. POLE TO BE REMOVED
- ⊖ (E) EXISTING LTG. POLE TO REMAIN "AS IS" ON THE EXISTING CIRCUIT DURING CONSTRUCTION STAGE I ONLY. TO BE REMOVED DURING CONSTRUCTION STAGE II.
- ▭ EXISTING PAVEMENT, SHOULDER CURB & GUTTER TO BE REMOVED BY OTHERS
- AC-XX— TEMPORARY AERIAL CABLE 3-1/C NO. 2 ALUMINUM WITH STEEL MESSENGER WIRE XX-INDICATES LENGTH IN METERS
- ⊖ (A) LIGHT POLE, WOOD, WITH 4.5M MAST ARM AND 400W HPS LUMINAIRES DURING CONSTRUCTION STAGE I ONLY AND TO BE REMOVED DURING CONSTRUCTION STAGE II. SEE NOTE-6 ON SHEET E-1. LETTER DENOTES CIRCUIT IN EXISTING CONTROLLER.
- LIGHT POLE, WOOD, FOR SUPPORT OF TEMPORARY AERIAL CABLE DURING CONSTRUCTION STAGE I
- ⊖ (X) EXISTING CONTROLLER TO BE REMOVED AT COMPLETION OF PROJECT
- ▨ CONSTRUCTION STAGE-I
- ▩ TEMPORARY PAVEMENT WITH TEMP. C&G

NOTES:

1. REFER TO LIGHTING NOTES ON DRAWING E-1.
2. SETBACK FOR THE TEMPORARY POLES SHALL BE 1.82 M (6') MINIMUM FROM THE BACK OF THE CURB.

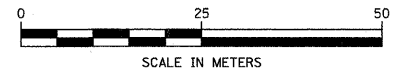
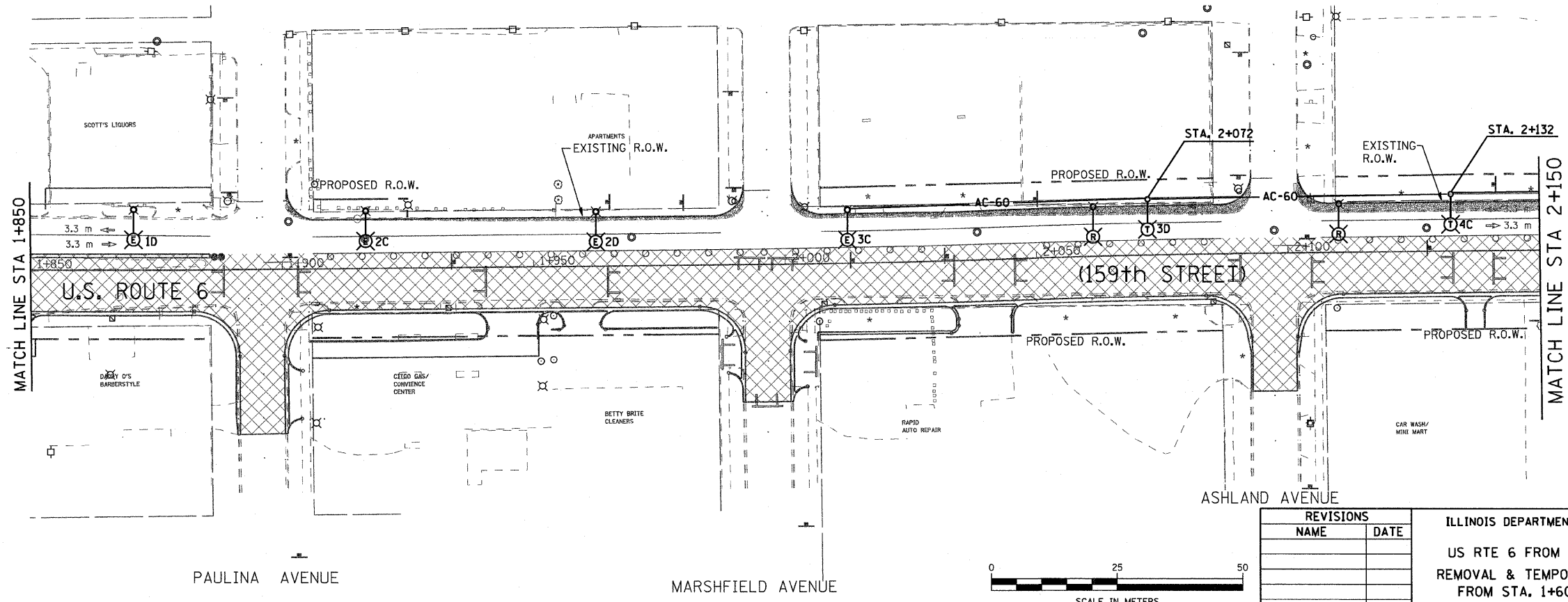
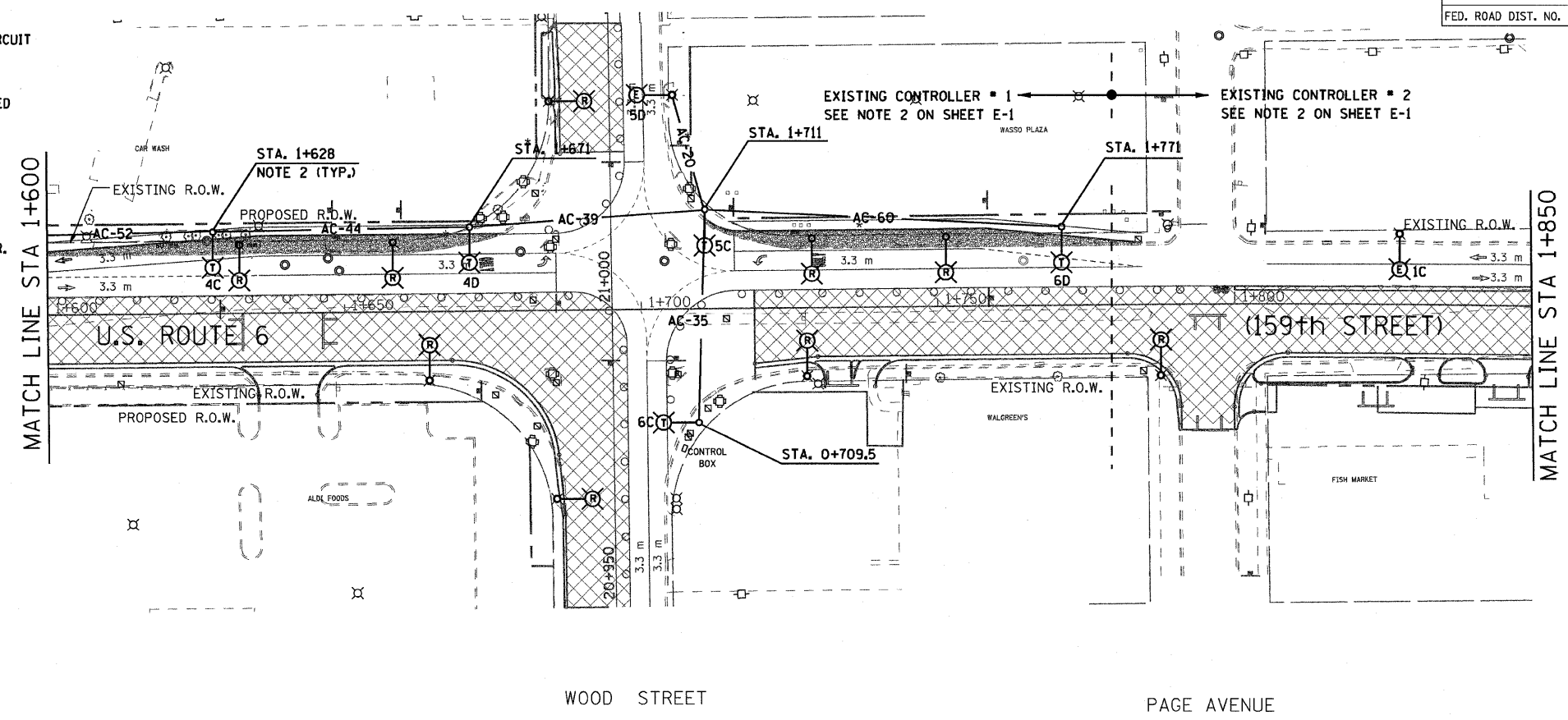

REVISIONS	
NAME	DATE

ILLINOIS DEPARTMENT OF TRANSPORTATION
 US RTE 6 FROM I-294 TO IL RTE 1
 REMOVAL & TEMPORARY LIGHTING PLAN
 FROM STA. 1+600 TO STA. 2+150

DATE 01/28/09
 DRAWN BY S.S./W.S.
 CHECKED BY C.K./H.S.

AEI Delta Engineering, Inc.
 CONSULTING ENGINEERS, CHICAGO, ILLINOIS

DRAWING No. E-4

F.A. RTE.	SECTION	COUNTY	TOTAL SHEETS	SHEET NO.
351	3277R	COOK	541	338
STA. 2+150		TO STA. 2+700		
FED. ROAD DIST. NO.		ILLINOIS FED. AID PROJECT		
CONTRACT NO. 60774				

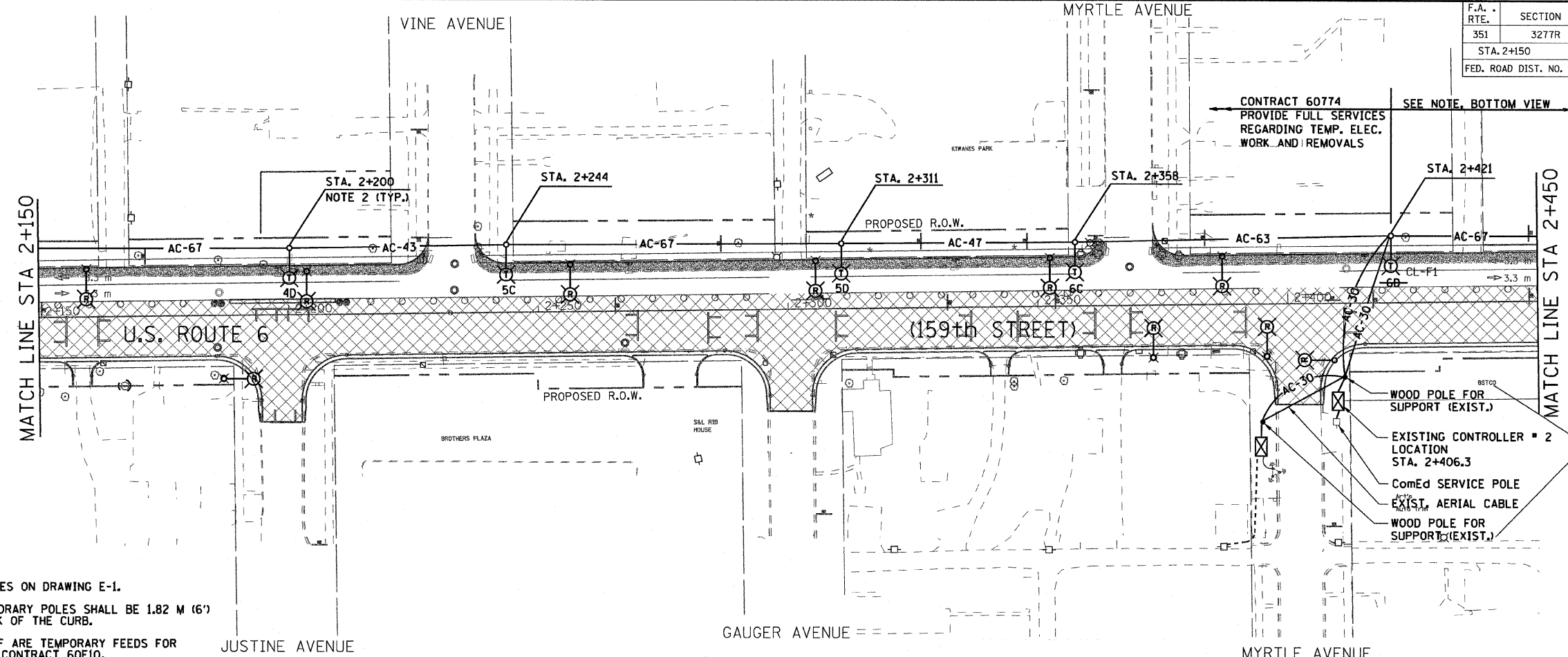

- NOTES:**
1. REFER TO LIGHTING NOTES ON DRAWING E-1.
 2. SETBACK FOR THE TEMPORARY POLES SHALL BE 1.82 M (6') MINIMUM FROM THE BACK OF THE CURB.
 3. CIRCUITS CL-E AND CL-F ARE TEMPORARY FEEDS FOR LIGHTING INSTALLED IN CONTRACT 60E10.

ALL ITEMS ARE TO BE REMOVED IN THIS CONTRACT (UPON COMPLETION OF NEW LIGHTING SYSTEM).

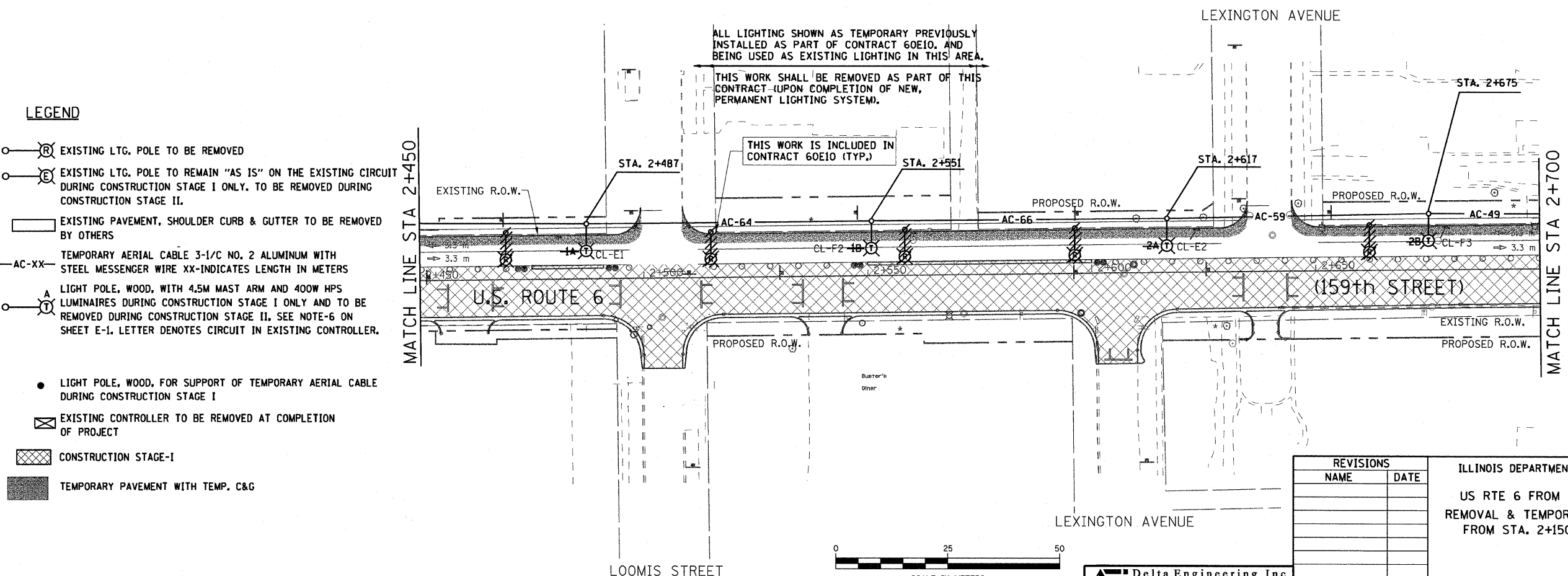

- LEGEND**
- ⊗ EXISTING LTC. POLE TO BE REMOVED
 - ⊕ EXISTING LTC. POLE TO REMAIN "AS IS" ON THE EXISTING CIRCUIT DURING CONSTRUCTION STAGE I ONLY. TO BE REMOVED DURING CONSTRUCTION STAGE II.
 - ▭ EXISTING PAVEMENT, SHOULDER CURB & GUTTER TO BE REMOVED BY OTHERS
 - AC-XX— TEMPORARY AERIAL CABLE 3-1/C NO. 2 ALUMINUM WITH STEEL MESSENGER WIRE XX-INDICATES LENGTH IN METERS
 - ⊙ LIGHT POLE, WOOD, WITH 4.5M MAST ARM AND 400W HPS LUMINAIRES DURING CONSTRUCTION STAGE I ONLY AND TO BE REMOVED DURING CONSTRUCTION STAGE II. SEE NOTE-6 ON SHEET E-1. LETTER DENOTES CIRCUIT IN EXISTING CONTROLLER.
 - LIGHT POLE, WOOD, FOR SUPPORT OF TEMPORARY AERIAL CABLE DURING CONSTRUCTION STAGE I
 - ⊗ EXISTING CONTROLLER TO BE REMOVED AT COMPLETION OF PROJECT
 - ▨ CONSTRUCTION STAGE-I
 - ▩ TEMPORARY PAVEMENT WITH TEMP. C&G

REVISIONS	
NAME	DATE

ILLINOIS DEPARTMENT OF TRANSPORTATION
 US RTE 6 FROM I-294 TO IL RTE 1
 REMOVAL & TEMPORARY LIGHTING PLAN
 FROM STA. 2+150 TO STA. 2+700

DATE 01/28/09

DRAWN BY S.S./W.S.
 CHECKED BY C.K./H.S.

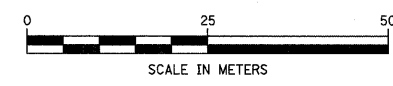

Delta Engineering, Inc.
 CONSULTING ENGINEERS, CHICAGO, ILLINOIS.

DRAWING No. E-5

F.A. RTE.	SECTION	COUNTY	TOTAL SHEETS	SHEET NO.
351	3277R	COOK	541	339
STA. 2+700		TO STA. 3+250		
FED. ROAD DIST. NO.		ILLINOIS FED. AID PROJECT		
CONTRACT NO. 60774				

LEGEND

- ⊙ (R) EXISTING LTG. POLE TO BE REMOVED
- ⊙ (E) EXISTING LTG. POLE TO REMAIN "AS IS" ON THE EXISTING CIRCUIT DURING CONSTRUCTION STAGE I ONLY. TO BE REMOVED DURING CONSTRUCTION STAGE II.
- ▭ EXISTING PAVEMENT, SHOULDER CURB & GUTTER TO BE REMOVED BY OTHERS
- AC-XX— TEMPORARY AERIAL CABLE 3-1/C NO. 2 ALUMINUM WITH STEEL MESSENGER WIRE XX-INDICATES LENGTH IN METERS
- ⊙ (A) LIGHT POLE, WOOD, WITH 4.5M MAST ARM AND 400W HPS LUMINAIRES DURING CONSTRUCTION STAGE I ONLY AND TO BE REMOVED DURING CONSTRUCTION STAGE II, SEE NOTE-6 ON SHEET E-1. LETTER DENOTES CIRCUIT IN EXISTING CONTROLLER.
- LIGHT POLE, WOOD, FOR SUPPORT OF TEMPORARY AERIAL CABLE DURING CONSTRUCTION STAGE I
- ⊠ EXISTING CONTROLLER TO BE REMOVED AT COMPLETION OF PROJECT
- ▨ CONSTRUCTION STAGE-I
- TEMPORARY PAVEMENT WITH TEMP. C&G

NOTES:

1. REFER TO LIGHTING NOTES ON DRAWING E-1.
2. SETBACK FOR THE TEMPORARY POLES SHALL BE 1.82 M (6') MINIMUM FROM THE BACK OF THE CURB.
3. CIRCUITS CM-A AND CM-B ARE TEMPORARY FEEDS FOR LIGHTING INSTALLED IN CONTRACT 60E10.
4. ALL LIGHTING COMPONENTS BETWEEN TEMPORARY WOOD POLES AT STATION 2+724 AND STATION 3+094 ARE PERMANENT TO REMAIN, AND WERE INSTALLED IN CONTRACT 60E10. SEE SHEET E-18 FOR ADDITIONAL INFORMATION.

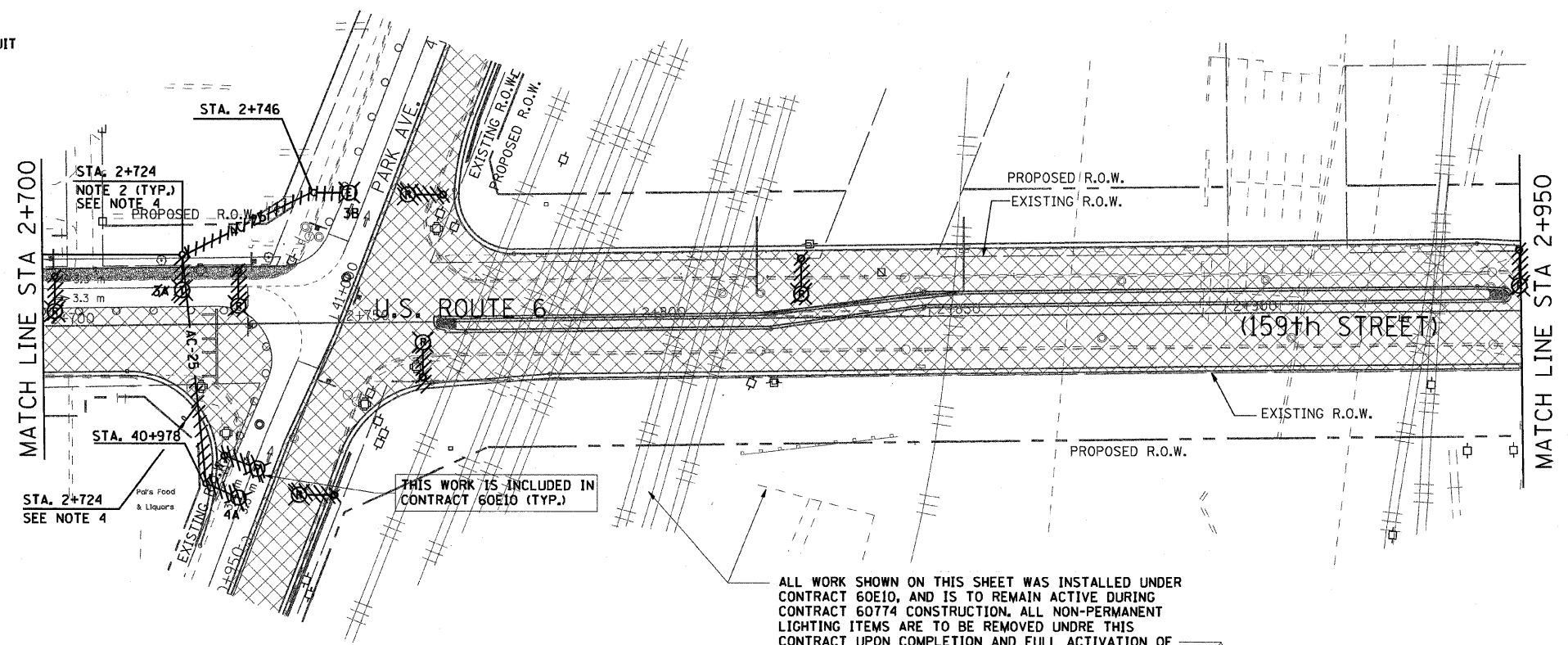

ALL WORK SHOWN ON THIS SHEET WAS INSTALLED UNDER CONTRACT 60E10, AND IS TO REMAIN ACTIVE DURING CONTRACT 60774 CONSTRUCTION. ALL NON-PERMANENT LIGHTING ITEMS ARE TO BE REMOVED UNDER THIS CONTRACT UPON COMPLETION AND FULL ACTIVATION OF THE PERMANENT LIGHTING SYSTEM.

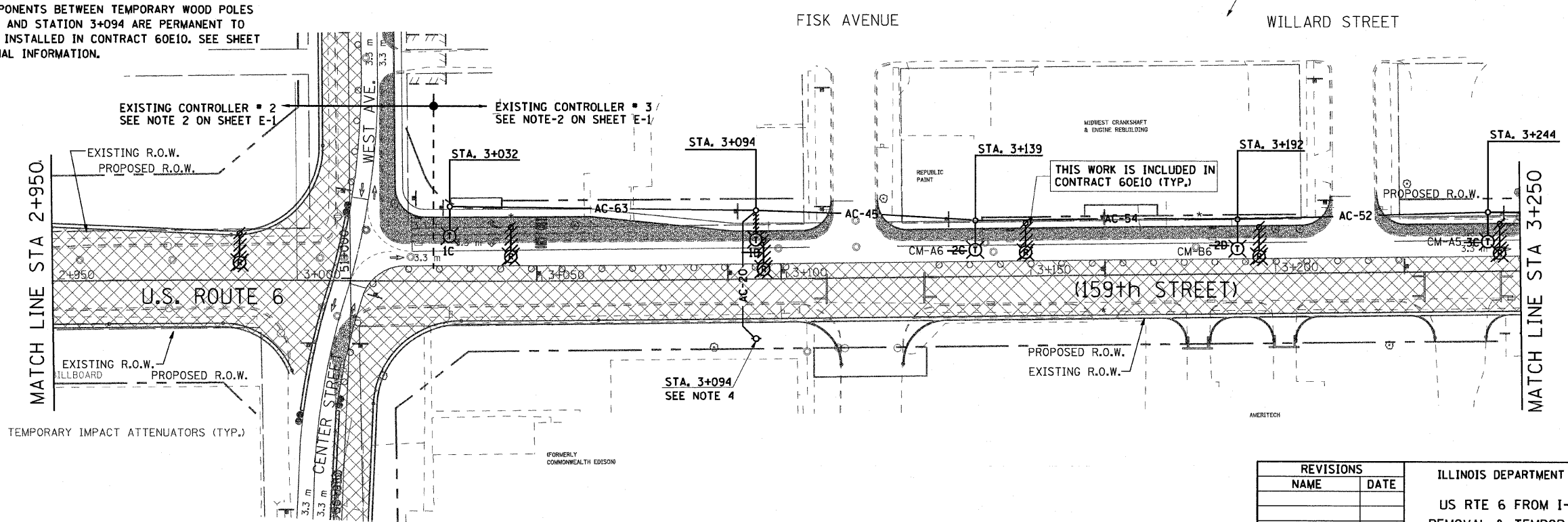

DRAWING No. E-6

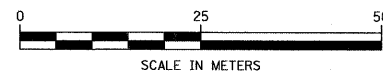

REVISIONS	
NAME	DATE

ILLINOIS DEPARTMENT OF TRANSPORTATION
 US RTE 6 FROM I-294 TO IL RTE 1
 REMOVAL & TEMPORARY LIGHTING PLAN
 FROM STA. 2+700 TO STA. 3+250

ΔE Delta Engineering, Inc.
 CONSULTING ENGINEERS, CHICAGO, ILLINOIS.

DRAWN BY S.S./W.S.
 CHECKED BY C.K./H.S.
 DATE 01/28/09

F.A. RTE.	SECTION	COUNTY	TOTAL SHEETS	SHEET NO.
351	3277R	COOK	541	340
STA. 3+250		TO STA. 3+850		
FED. ROAD DIST. NO.		ILLINOIS	FED. AID PROJECT	
CONTRACT NO. 60774				

NOTES:

- REFER TO LIGHTING NOTES ON DRAWING E-1.
- SETBACK FOR THE TEMPORARY POLES SHALL BE 1.82 M (6') MINIMUM FROM THE BACK OF THE CURB.
- CIRCUITS CM-A AND CM-B ARE TEMPORARY FEEDS FOR LIGHTING INSTALLED IN CONTRACT 60E10.

ALL LIGHTING SHOWN AS TEMPORARY PREVIOUSLY INSTALLED AS PART OF CONTRACT 60E10, AND BEING USED AS EXISTING LIGHTING IN THIS AREA.

THIS WORK SHALL BE REMOVED AS PART OF THIS CONTRACT (UPON COMPLETION OF NEW, PERMANENT LIGHTING SYSTEM).

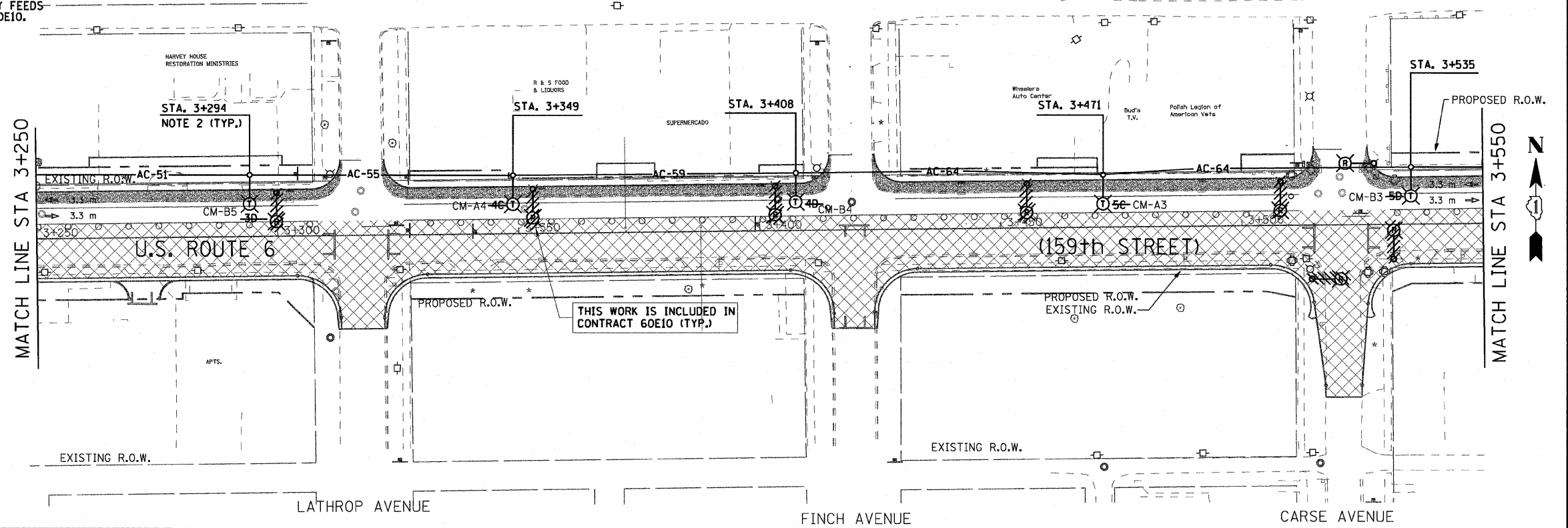

- LEGEND**
- EXISTING LTG. POLE TO BE REMOVED
 - EXISTING LTG. POLE TO REMAIN "AS IS" ON THE EXISTING CIRCUIT DURING CONSTRUCTION STAGE I ONLY. TO BE REMOVED DURING CONSTRUCTION STAGE II
 - EXISTING PAVEMENT, SHOULDER CURB & GUTTER TO BE REMOVED BY OTHERS
 - TEMPORARY AERIAL CABLE 3-1/2" NO. 2 ALUMINUM WITH STEEL MESSENGER WIRE XX-INDICATES LENGTH IN METERS
 - LIGHT POLE, WOOD, WITH 4.5M MAST ARM AND 400W HPS LUMINAIRES DURING CONSTRUCTION STAGE I ONLY AND TO BE REMOVED DURING CONSTRUCTION STAGE II. SEE NOTE-6 ON SHEET E-1. LETTER DENOTES CIRCUIT IN EXISTING CONTROLLER.
 - LIGHT POLE, WOOD, FOR SUPPORT OF TEMPORARY AERIALCABLE DURING CONSTRUCTION STAGE I
 - EXISTING CONTROLLER TO BE REMOVED AT COMPLETION OF PROJECT
 - CONSTRUCTION STAGE I.
 - TEMPORARY PAVEMENT WITH TEMP. C&G

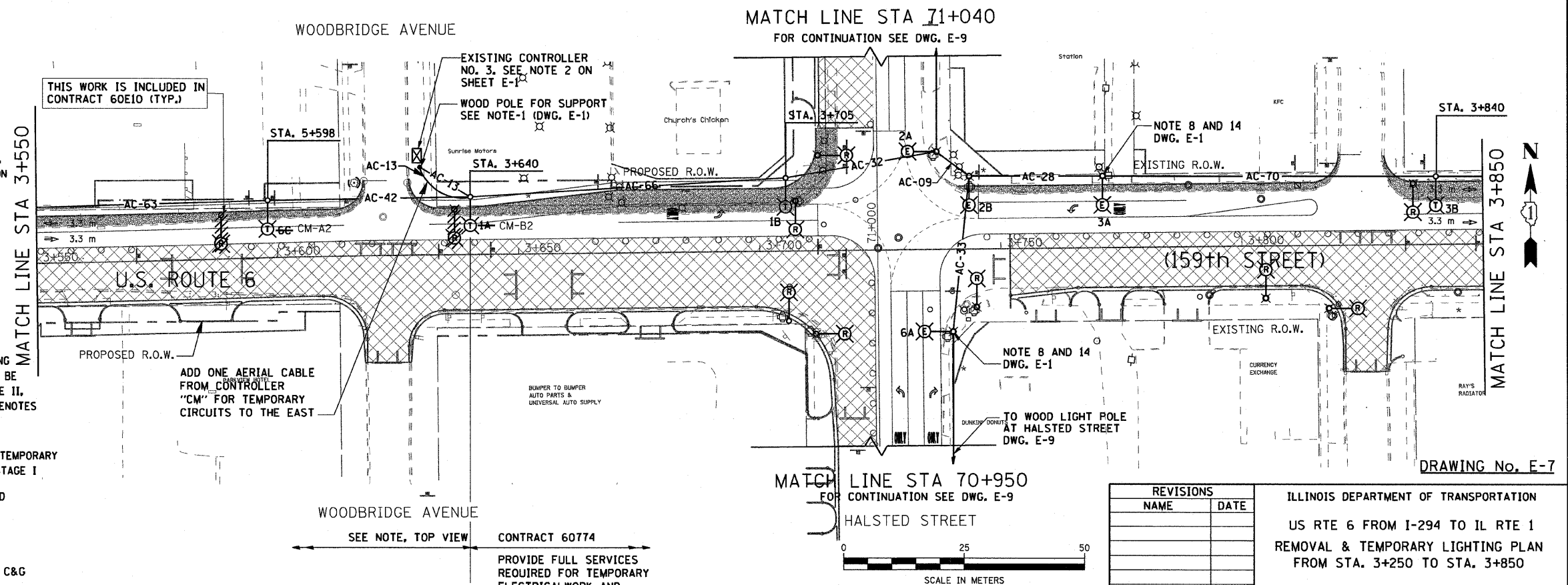

REVISIONS	
NAME	DATE

ILLINOIS DEPARTMENT OF TRANSPORTATION
 US RTE 6 FROM I-294 TO IL RTE 1
 REMOVAL & TEMPORARY LIGHTING PLAN
 FROM STA. 3+250 TO STA. 3+850

DATE 01/28/09

DRAWN BY S.S./W.S.
 CHECKED BY C.K./H.S.

Delta Engineering, Inc.
 CONSULTING ENGINEERS, CHICAGO, ILLINOIS

CONTRACT 60774
 PROVIDE FULL SERVICES
 REQUIRED FOR TEMPORARY
 ELECTRICALWORK AND
 REMOVALS

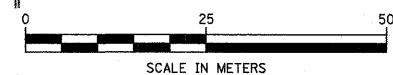

DRAWING No. E-7

F.A. RTE.	SECTION	COUNTY	TOTAL SHEETS	SHEET NO.
351	3277R	COOK	541	341
STA. 3+850		TO STA. 4+100		
FED. ROAD DIST. NO.		ILLINOIS FED. AID PROJECT		
CONTRACT NO. 60774				

NOTES:

- REFER TO LIGHTING NOTES ON DRAWING E-1.
- SETBACK FOR THE TEMPORARY POLES SHALL BE 1.82 M (6') MINIMUM FROM THE BACK OF THE CURB.

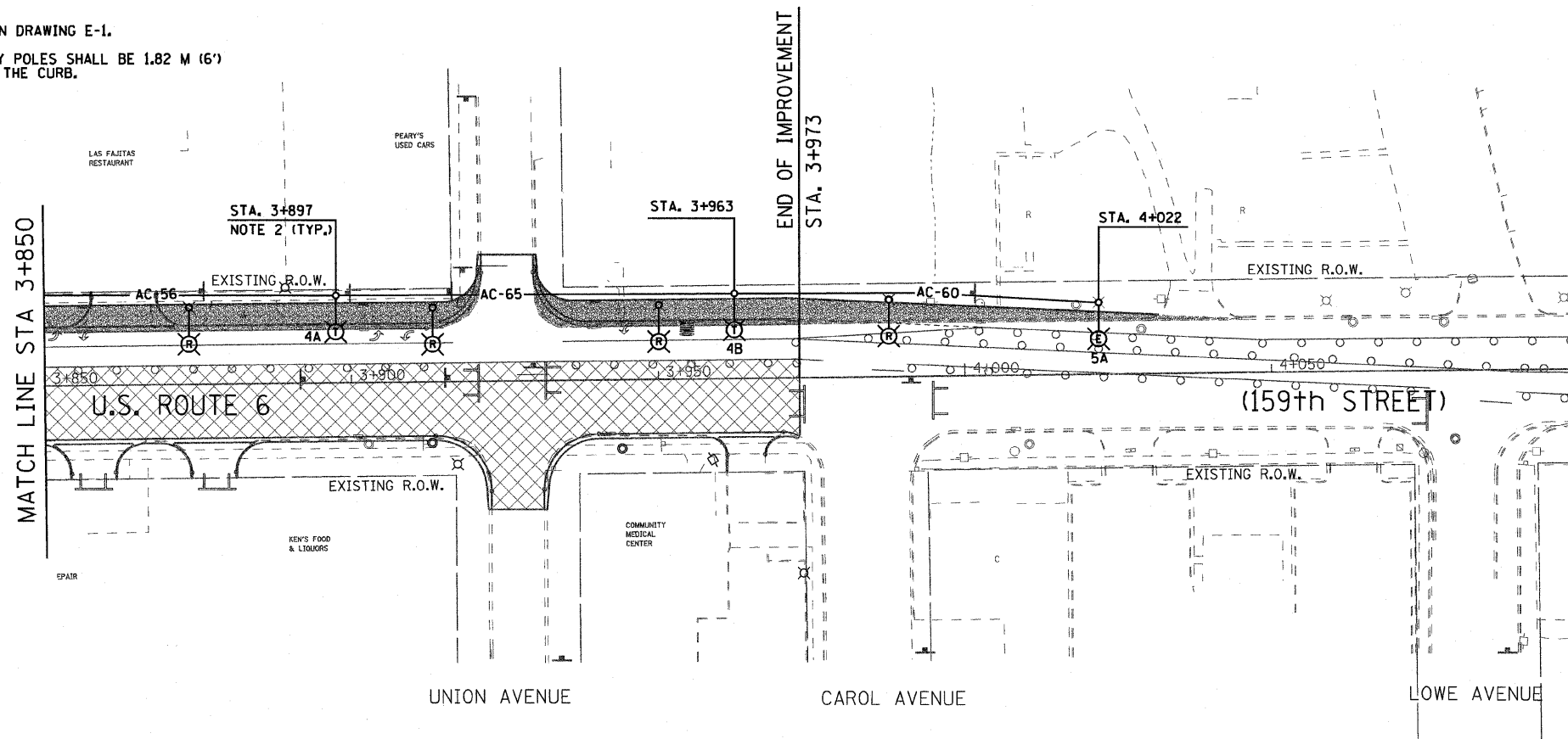

LEGEND

- (R) EXISTING LTG. POLE TO BE REMOVED
- (E) EXISTING LTG. POLE TO REMAIN "AS IS" ON THE EXISTING CIRCUIT DURING CONSTRUCTION STAGE I ONLY, TO BE REMOVED DURING CONSTRUCTION STAGE II.
- EXISTING PAVEMENT, SHOULDER CURB & GUTTER TO BE REMOVED BY OTHERS
- AC-XX— TEMPORARY AERIAL CABLE 3-1/C NO. 2 ALUMINUM WITH STEEL MESSENGER WIRE XX-INDICATES LENGTH IN METERS
- (T) LIGHT POLE, WOOD, WITH 4.5M MAST ARM AND 400W HPS LUMINAIRES DURING CONSTRUCTION STAGE I ONLY AND TO BE REMOVED DURING CONSTRUCTION STAGE II, SEE NOTE-6 ON SHEET E-1. LETTER DENOTES CIRCUIT IN EXISTING CONTROLLER.
- LIGHT POLE, WOOD, FOR SUPPORT OF TEMPORARY AERIAL CABLE DURING CONSTRUCTION STAGE I
- ⊠ EXISTING CONTROLLER TO BE REMOVED AT COMPLETION OF PROJECT
- ▨ CONSTRUCTION STAGE-I
- TEMPORARY PAVEMENT WITH TEMP. C&G

DRAWING No. E-8

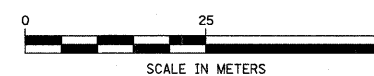

Delta Engineering, Inc.
CONSULTING ENGINEERS, CHICAGO, ILLINOIS

REVISIONS	
NAME	DATE

ILLINOIS DEPARTMENT OF TRANSPORTATION
US RTE 6 FROM I-294 TO IL RTE 1
REMOVAL & TEMPORARY LIGHTING PLAN
FROM STA. 3+850 TO STA. 4+100

DRAWN BY S.S./W.S.
CHECKED BY C.K./H.S.
DATE 01/28/09

F.A. RTE.	SECTION	COUNTY	TOTAL SHEETS	SHEET NO.
351	3277R	COOK	541	342
STA. 70+880		TO STA. 71+200		
FED. ROAD DIST. NO.		ILLINOIS FED. AID PROJECT		
CONTRACT NO. 60774				

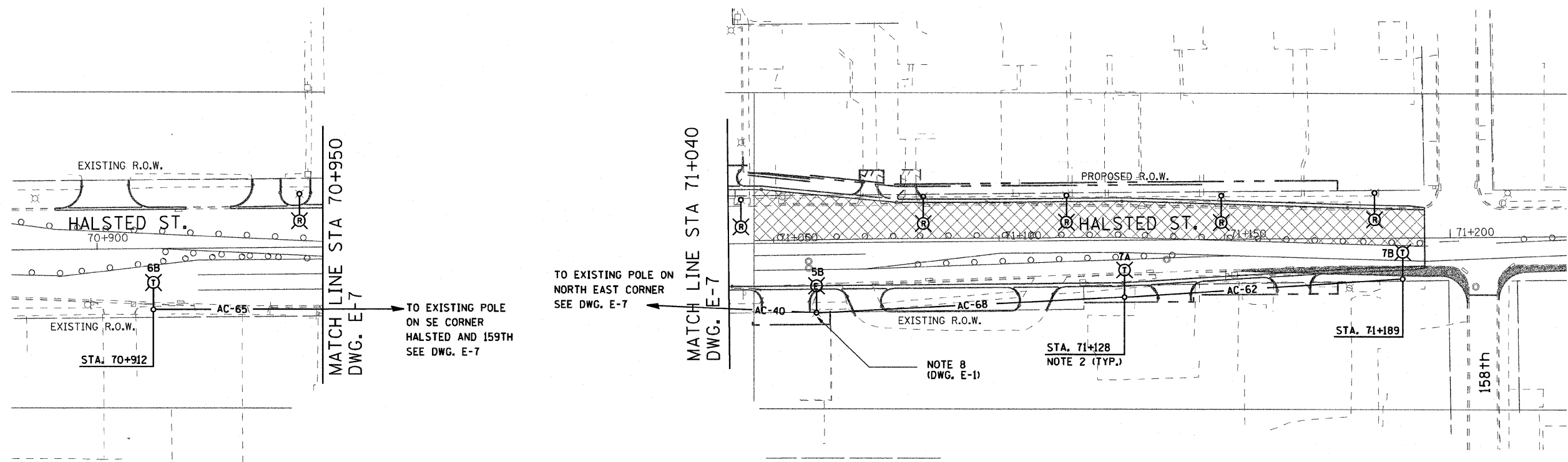

TO EXISTING POLE ON NORTH EAST CORNER SEE DWG. E-7

TO EXISTING POLE ON SE CORNER HALSTED AND 159TH SEE DWG. E-7

LEGEND

- ⊖(R) EXISTING LTG. POLE TO BE REMOVED
- ⊖(E) EXISTING LTG. POLE TO REMAIN "AS IS" ON THE EXISTING CIRCUIT DURING CONSTRUCTION STAGE I ONLY. TO BE REMOVED DURING CONSTRUCTION STAGE II
- ▭ EXISTING PAVEMENT, SHOULDER CURB & GUTTER TO BE REMOVED BY OTHERS
- AC-XX- AERIAL CABLE 3-1/C NO. 2 ALUMINUM WITH STEEL MESSENGER WIRE XX-INDICATES LENGTH IN METERS
- ⊖(A) LIGHT POLE, WOOD, WITH 4.5M MAST ARM AND 400W HPS LUMINAIRES DURING CONSTRUCTION STAGE I ONLY AND TO BE REMOVED DURING CONSTRUCTION STAGE II, SEE NOTE-6 ON SHEET E-1. LETTER DENOTES CIRCUIT IN EXISTING CONTROLLER.
- LIGHT POLE, WOOD, FOR SUPPORT OF TEMPORARY AERIAL CABLE DURING CONSTRUCTION STAGE I
- ⊖(X) EXISTING CONTROLLER TO BE REMOVED AT COMPLETION OF PROJECT
- ▨ CONSTRUCTION STAGE I.
- ▩ TEMPORARY PAVEMENT WITH TEMP. C&G

NOTES:

1. REFER TO LIGHTING NOTES ON DRAWING E-1.
2. SETBACK FOR THE TEMPORARY POLES SHALL BE 1.82 M (6') MINIMUM FROM THE BACK OF THE CURB.

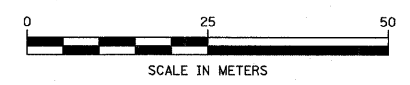

Delta Engineering, Inc.
CONSULTING ENGINEERS, CHICAGO ILLINOIS.

REVISIONS	
NAME	DATE

DRAWING No. E-9

ILLINOIS DEPARTMENT OF TRANSPORTATION
US RTE 6 FROM I-294 TO IL RTE 1
REMOVAL & TEMPORARY LIGHTING PLANS
STA. 70+880 TO STA. 71+200

DATE 01/28/09

DRAWN BY S.S./W.S.
CHECKED BY C.K./H.S.

F.A. RTE.	SECTION	COUNTY	TOTAL SHEETS	SHEET NO.
351	3277R	COOK	541	343
STA. 10+770		TO STA. 10+120		
FED. ROAD DIST. NO.		ILLINOIS FED. AID PROJECT		
CONTRACT NO. 60774				

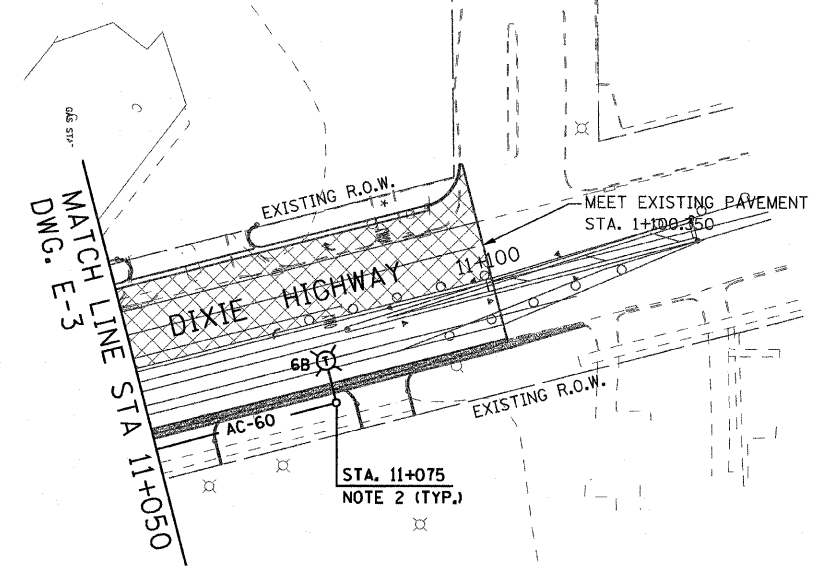
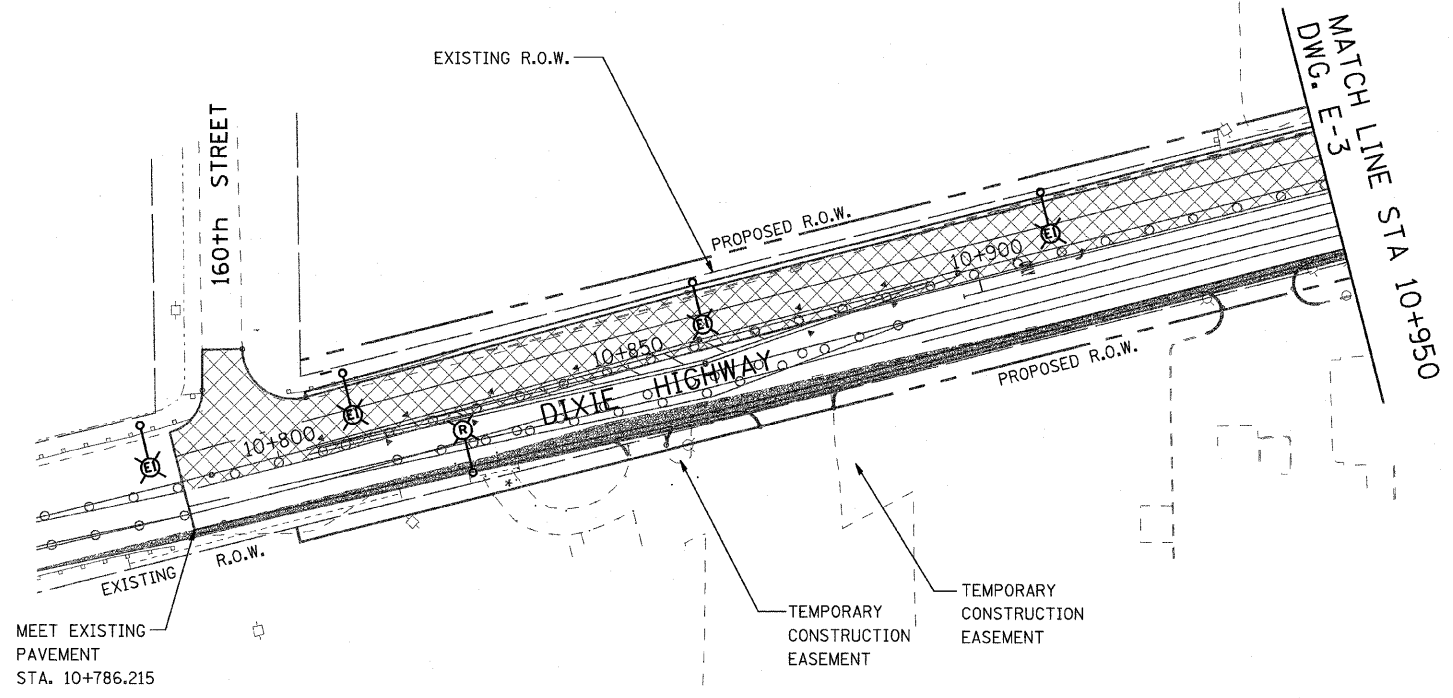
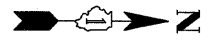

LEGEND

- (R) EXISTING LTG. POLE TO BE REMOVED
- (E) EXISTING LTG. POLE TO REMAIN "AS IS" ON THE EXISTING CIRCUIT DURING CONSTRUCTION STAGE I ONLY. TO BE REMOVED DURING CONSTRUCTION STAGE II.
- (ER) EXISTING LTG. POLE TO REMAIN
- ▭ EXISTING PAVEMENT, SHOULDER CURB & GUTTER TO BE REMOVED BY OTHERS
- AC-XX- AERIAL CABLE 3-1/C NO. 2 ALUMINUM WITH STEEL MESSENGER WIRE XX-INDICATES LENGTH IN METERS
- (T) LIGHT POLE, WOOD, WITH 4.5M MAST ARM AND 400W HPS LUMINAIRES DURING CONSTRUCTION STAGE I ONLY AND TO BE REMOVED DURING CONSTRUCTION STAGE II, SEE NOTE-6 ON SHEET E-1. LETTER DENOTES CIRCUIT IN EXISTING CONTROLLER.
- LIGHT POLE, WOOD, FOR SUPPORT OF TEMPORARY AERIAL CABLE DURING CONSTRUCTION STAGE I
- ▣ EXISTING CONTROLLER TO BE REMOVED AT COMPLETION OF PROJECT
- ▨ CONSTRUCTION STAGE-I
- TEMPORARY PAVEMENT WITH TEMP. C&G

NOTES:

1. REFER TO LIGHTING NOTES ON DRAWING E-1.
2. SETBACK FOR THE TEMPORARY POLES SHALL BE 1.82 M (6') MINIMUM FROM THE BACK OF THE CURB.

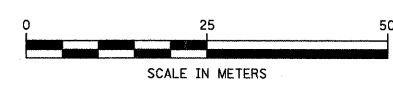

Delta Engineering, Inc.
CONSULTING ENGINEERS, CHICAGO, ILLINOIS

REVISIONS	
NAME	DATE











DRAWING No. E-10

ILLINOIS DEPARTMENT OF TRANSPORTATION
US RTE 6 FROM I-294 TO IL RTE 1
REMOVAL & TEMPORARY LIGHTING PLANS
STA. 10+785 TO STA. 11+100

DRAWN BY S.S./W.S.
CHECKED BY C.K./H.S.
DATE 01/28/09

F.A. RTE.	SECTION	COUNTY	TOTAL SHEETS	SHEET NO.
351	327TR	COOK	541	344
STA. 0+450		TO STA. 1+000		
FED. ROAD DIST. NO.		ILLINOIS FED. AID PROJECT		
CONTRACT NO. 60774				

LEGEND

-  CH-AX PROPOSED ALUMINUM LIGHT POLE (14.5 M M.H., 2.5M MAST ARM), FOUNDATION & 310W HPS LUMINAIRE. 'CH' DENOTES CONTROLLER NO. 'A' DENOTES CIRCUIT NUMBER. 'X' DENOTES POLE NO. 'B' DENOTES BREAKAWAY DEVICE AT THE POLE BASE.
-  --- UNDER GROUND SERVICE 50mm GALVANIZED STEEL
-   EXISTING CONTROLLER TO BE REMOVED AT COMPLETION OF PROJECT
-  PROPOSED CONTROLLER
-  GS GALVANIZED STEEL
-  TU XX TU DENOTES UNIT DUCT IN TRENCH, SIZES AS NOTED ON PLANS, XX-DENOTES LENGTH IN METERS.
-   GROUND ROD, 16MM DIA. X 3.0M LONG
-  GALVANIZED STEEL CONDUIT IN TRENCH (T) UNDER DRIVEWAYS/PAVEMENT 50MM, XX DENOTES LENGTH IN METERS.
-  GROUND FIELD FOR CONTROLLERS. 2/0 AWG BARE COPPER WIRE

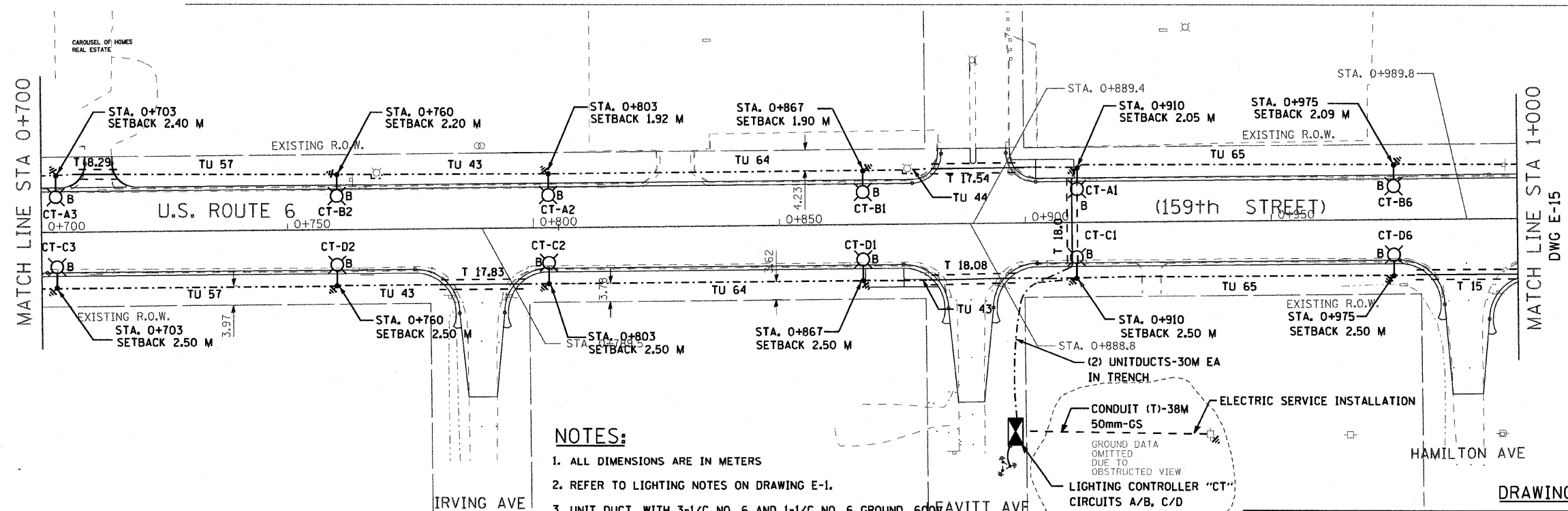
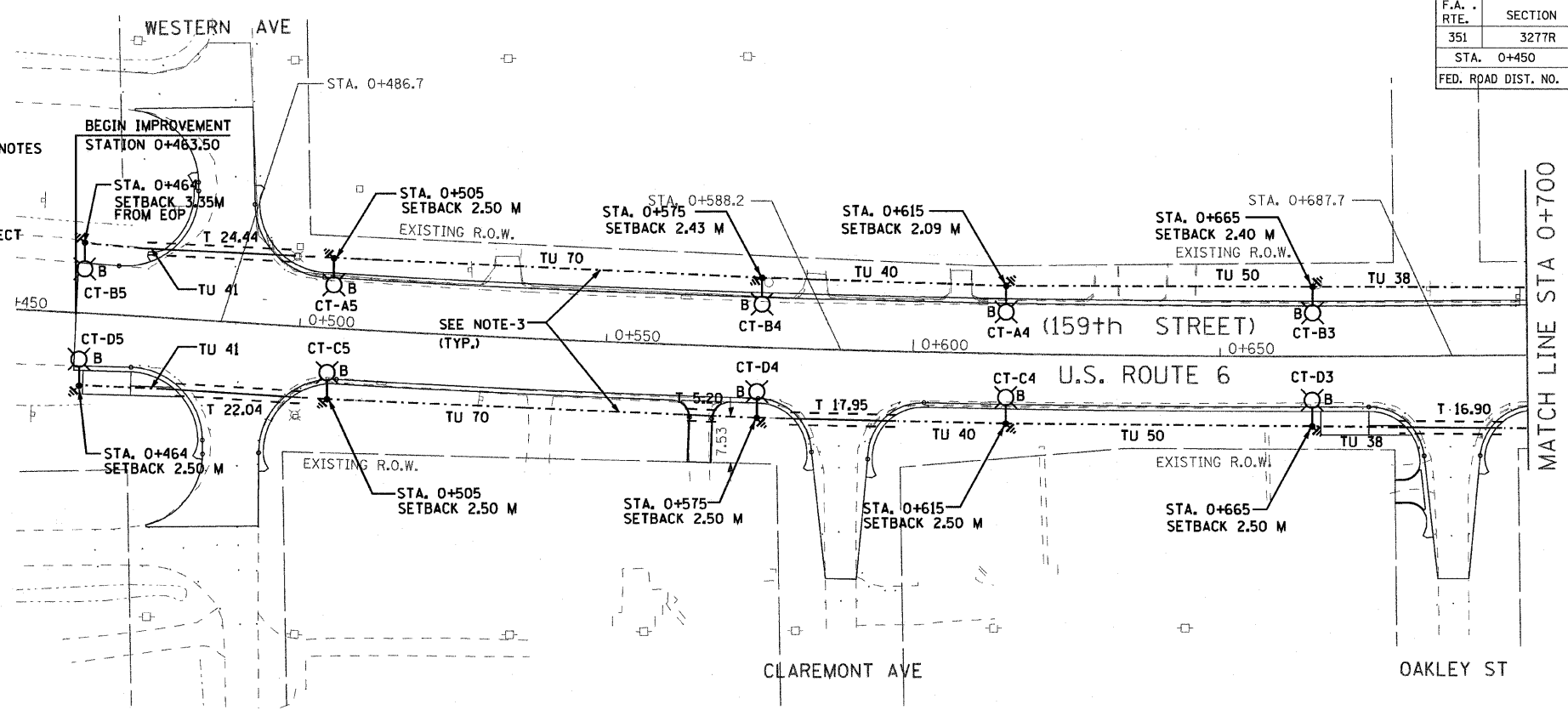

NOTES:

1. ALL DIMENSIONS ARE IN METERS
2. REFER TO LIGHTING NOTES ON DRAWING E-1.
3. UNIT DUCT, WITH 3-1/C NO. 6 AND 1-1/C NO. 6 GROUND, 600V (EPR-TYPE RHW), 25MM DIA., POLYETHYLENE.
4. POLES SETBACK ARE MEASURED FROM BACK OF THE CURB.

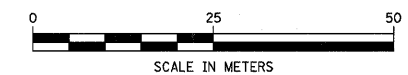

Delta Engineering, Inc.
CONSULTING ENGINEERS, CHICAGO, ILLINOIS

REVISIONS	
NAME	DATE

ILLINOIS DEPARTMENT OF TRANSPORTATION
US RTE 6 FROM I-294 TO IL RTE 1
PROPOSED LIGHTING PLAN
AND POLE LOCATIONS
FROM STA. 0+450 TO STA. 1+000

SCALE AS NOTED
DATE 01/28/09

DRAWN BY S.S./W.S.
CHECKED BY C.K./H.S.

DRAWING No. E-14

F.A. RTE.	SECTION	COUNTY	TOTAL SHEETS	SHEET NO.
351	327TR	COOK	541	345
STA. 1+000		TO STA. 1+600		
FED. ROAD DIST. NO. ILLINOIS FED. AID PROJECT				

CONTRACT NO. 60774

LEGEND

- CH-AX
B
PROPOSED ALUMINUM LIGHT POLE (14.5 M M.H., 2.5M MAST ARM), FOUNDATION & 310W HPS LUMINAIRE. 'CH' DENOTES CONTROLLER NO. 'A' DENOTES CIRCUIT NUMBER, 'X' DENOTES POLE NO. 'B' DENOTES BREAKAWAY DEVICE AT THE POLE BASE.
- UNDER GROUND SERVICE 50mm GALVANIZED STEEL
- ⊠
EXISTING CONTROLLER TO BE REMOVED AT COMPLETION OF PROJECT
- ⊠
PROPOSED CONTROLLER
- GS
GALVANIZED STEEL
- TU XX
TU DENOTES UNIT DUCT IN TRENCH, SIZES AS NOTED ON PLANS, XX-DENOTES LENGTH IN METERS.
- ⊥
GROUND ROD, 16MM DIA, X 3.0M LONG
- T XX
GALVANIZED STEEL CONDUIT IN TRENCH (T UNDER DRIVEWAYS/PAVEMENT 50MM, XX DENOTES LENGTH IN METERS.
- ⊥
GROUND FIELD FOR CONTROLLERS. 2/0 AWG BARE COPPER WIRE
- ⊥
STEEL COMBINATION MAST ARM ASSEMBLY AND POLE (BY TRAFFIC SIGNAL CONTRACTOR, SEE NOTE-4)

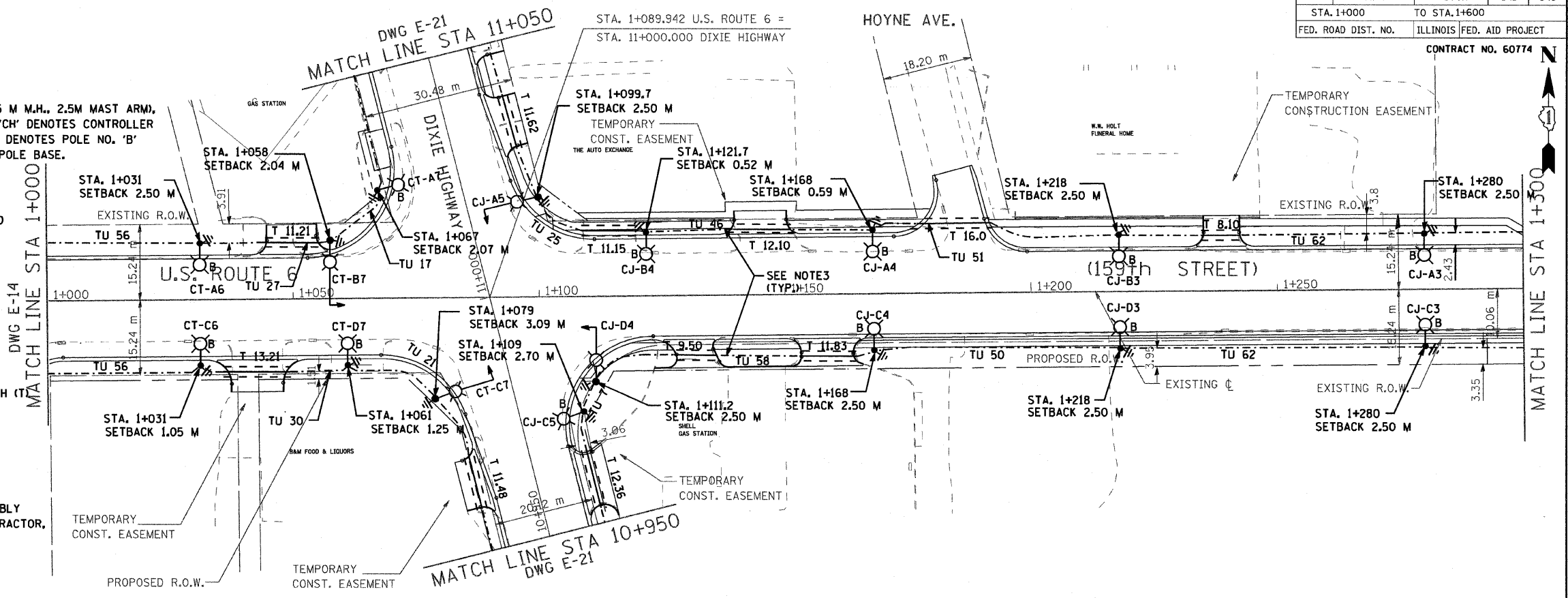

NOTES:

1. ALL DIMENSIONS ARE IN METERS
2. REFER TO LIGHTING NOTES ON DRAWING E-1.
3. UNIT DUCT, WITH 3-1/2 NO. 6 AND 1-1/2 NO. 6 GROUND, 600V (EPR-TYPE RHW), 25MM DIA., POLYETHYLENE UNLESS OTHERWISE NOTED.
4. LUMINAIRES ON THE COMBINATION MAST ARM ASSEMBLY SHALL BE FURNISHED, INSTALLED AND WIRED BY THE LIGHTING CONTRACTOR.
5. POLES SETBACK ARE MEASURED FROM BACK OF THE CURB.

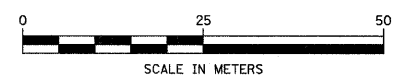
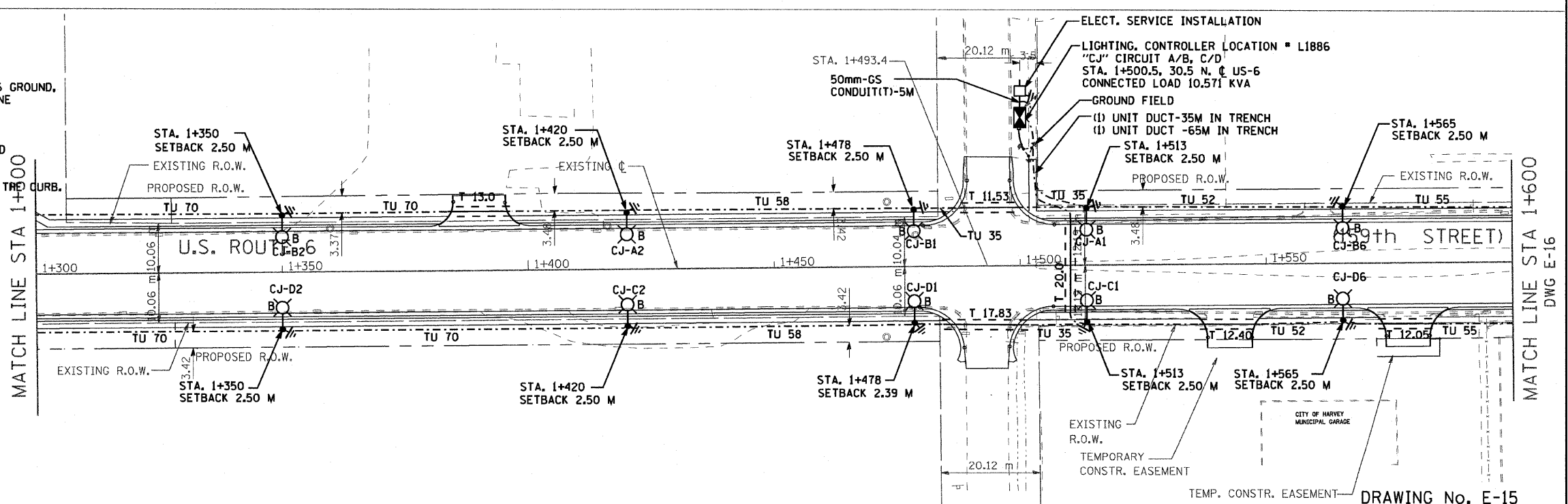

Delta Engineering, Inc.
CONSULTING ENGINEERS, CHICAGO, ILLINOIS

REVISIONS	
NAME	DATE

ILLINOIS DEPARTMENT OF TRANSPORTATION
US RTE 6 FROM I-294 TO IL RTE 1
PROPOSED LIGHTING PLAN
AND POLES LOCATIONS
FROM STA. 1+000 TO STA. 1+600

SCALE AS NOTED
DATE 01/28/09

DRAWN BY S.S./W.S.
CHECKED BY C.K./H.S.

F.A. RTE.	SECTION	COUNTY	TOTAL SHEETS	SHEET NO.
351	3277R	COOK	541	346
STA. 1+600		TO STA. 2+150		
FED. ROAD DIST. NO.		ILLINOIS FED. AID PROJECT		CONTRACT NO. 60774

LEGEND

- CH-AX
B
PROPOSED ALUMINUM LIGHT POLE (14.5 M M.H., 2.5M MAST ARM), FOUNDATION & 310W HPS LUMINAIRE. 'CH' DENOTES CONTROLLER NO. 'A' DENOTES CIRCUIT NUMBER. 'X' DENOTES POLE NO. 'B' DENOTES BREAKAWAY DEVICE AT THE POLE BASE.
- UNDER GROUND SERVICE 50mm GALVANIZED STEEL
- ⊠ EXISTING CONTROLLER TO BE REMOVED AT COMPLETION OF PROJECT
- ⊠ PROPOSED CONTROLLER
- GS GALVANIZED STEEL
- TU XX TU DENOTES UNIT DUCT IN TRENCH, SIZES AS NOTED ON PLANS. XX-DENOTES LENGTH IN METERS.
- ⏏ GROUND ROD, 16MM DIA. X 3.0M LONG
- T XX GALVANIZED STEEL CONDUIT IN TRENCH (T) UNDER DRIVEWAYS/PAVEMENT 50MM, XX DENOTES LENGTH IN METERS.
- ⏏ GROUND FIELD FOR CONTROLLERS. 2/0 AWG BARE COPPER WIRE
- ⊠ STEEL COMBINATION MAST ARM ASSEMBLY AND POLE (BY TRAFFIC SIGNAL CONTRACTOR, SEE NOTE-4)

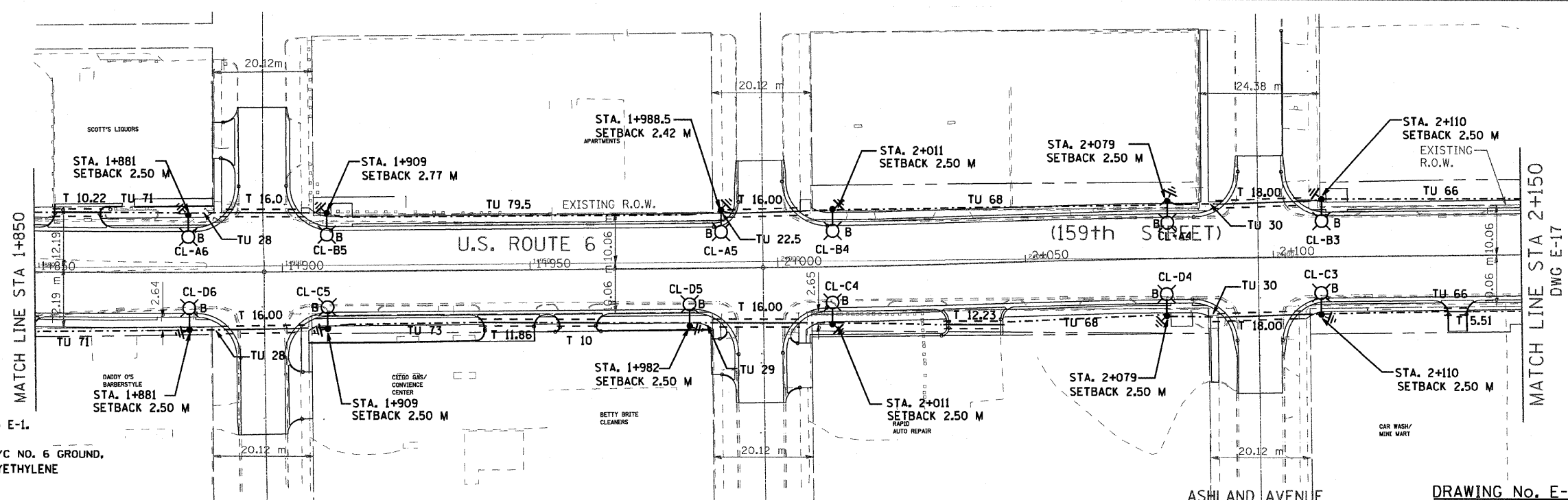
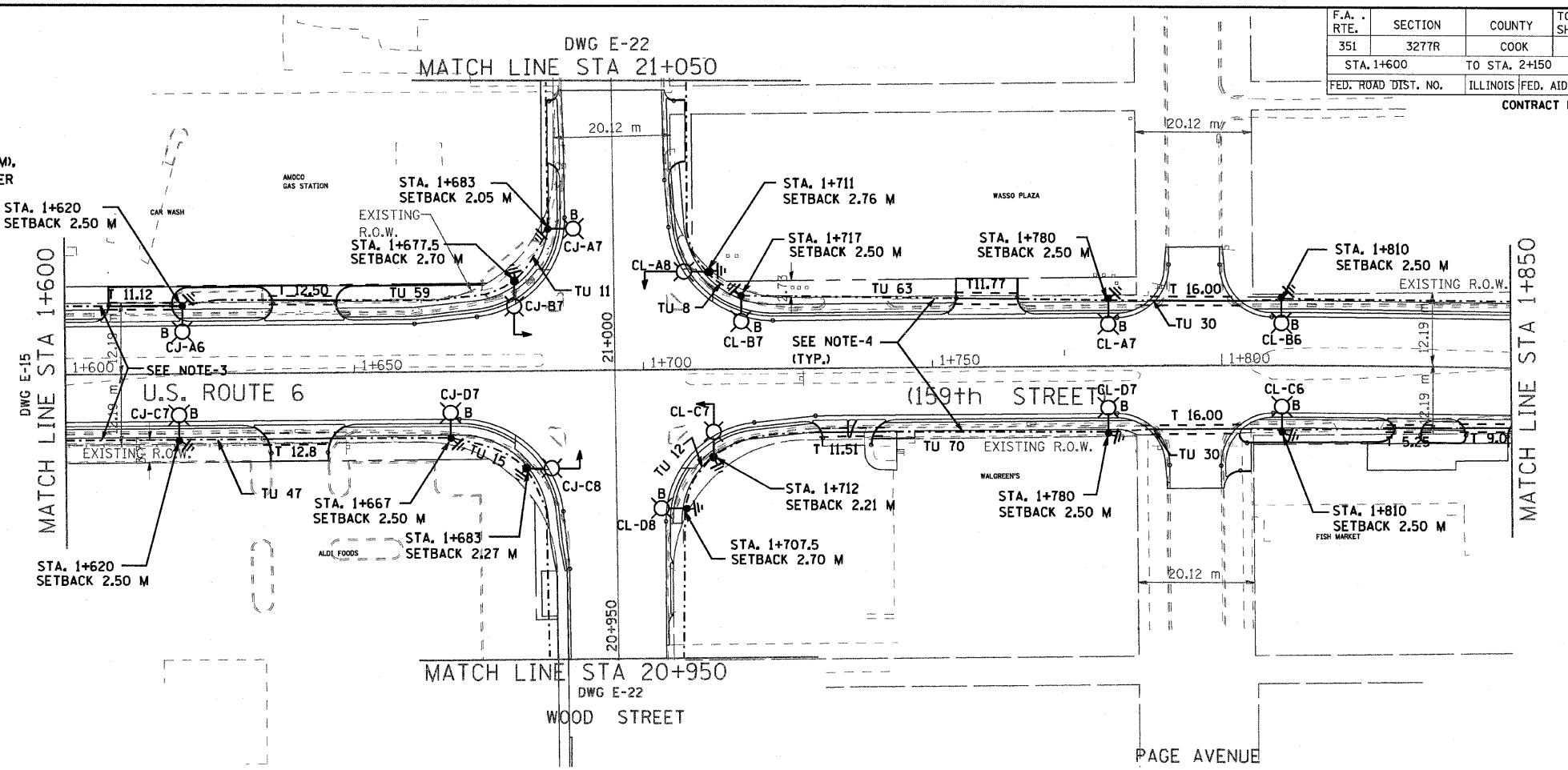

NOTES:

1. ALL DIMENSIONS ARE IN METERS.
2. REFER TO LIGHTING NOTES ON DRAWING E-1.
3. UNIT DUCT, WITH 3-1/2 NO. 6 AND 1-1/2 NO. 6 GROUND, 600V (EPR-TYPE RHW), 25MM DIA., POLYETHYLENE UNLESS OTHERWISE NOTED.
4. UNIT DUCT, WITH 3-1/2 NO. 4 AND 1-1/2 NO. 6 GROUND 600V (EPR-TYPE RHW), 30MM DIA., POLYETHYLENE (CKTS. CL-A/B & CL-C/D ONLY)
5. LUMINAIRES ON THE COMBINATION MAST ARM ASSEMBLY SHALL BE FURNISHED, INSTALLED AND WIRED BY THE LIGHTING CONTRACTOR.
6. POLES SETBACK ARE MEASURED FROM BACK OF THE CURB.

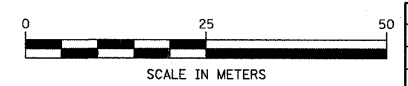

REVISIONS	
NAME	DATE

DRAWING No. E-16

ILLINOIS DEPARTMENT OF TRANSPORTATION

US RTE 6 FROM I-294 TO IL RTE 1
PROPOSED LIGHTING PLAN
AND POLES LOCATIONS
FROM STA. 1+600 TO STA. 2+150

SCALE AS NOTED
DATE 01/28/09

DRAWN BY S.S./W.S.
CHECKED BY C.K./H.S.

F.A. RTE.	SECTION	COUNTY	TOTAL SHEETS	SHEET NO.
351	327TR	COOK	541	347
STA. 2+150		TO STA. 2+700		
FED. ROAD DIST. NO.		ILLINOIS FED. AID PROJECT		
CONTRACT NO. 60774				

LEGEND

- P XX GALVANIZED STEEL CONDUIT PUSHED (P) UNDER DRIVEWAYS/PAVEMENT 65MM, XX DENOTES LENGTH IN METERS.
- PROPOSED ALUMINUM LIGHT POLE (14.5 M M.H., 2.5M MAST ARM), FOUNDATION & 310W HPS LUMINAIRE. 'CH' DENOTES CONTROLLER NO. 'A' DENOTES CIRCUIT NUMBER. 'X' DENOTES POLE NO. 'B' DENOTES BREAKAWAY DEVICE AT THE POLE BASE.
- UNDER GROUND SERVICE 50mm GALVANIZED STEEL
- EXISTING CONTROLLER TO BE REMOVED AT COMPLETION OF PROJECT
- PROPOSED CONTROLLER
- GS GALVANIZED STEEL
- TU XX DENOTES UNIT DUCT IN TRENCH, SIZES AS NOTED ON PLANS, XX-DENOTES LENGTH IN METERS.
- GROUND ROD, 16MM DIA, X 3.0M LONG
- T XX GALVANIZED STEEL CONDUIT IN TRENCH (T) UNDER DRIVEWAYS/PAVEMENT 50MM, XX DENOTES LENGTH IN METERS.
- GROUND FIELD FOR CONTROLLERS. 2/0 AWG BARE COPPER WIRE

NOTES:

1. ALL DIMENSIONS ARE IN METERS.
2. REFER TO LIGHTING NOTES ON DRAWING E-1.
3. UNIT DUCT, WITH 3-1/C NO. 6 AND 1-1/C NO. 6 GROUND, 600V (EPR-TYPE RHW), 25MM DIA., POLYETHYLENE UNLESS OTHERWISE NOTED.
4. UNIT DUCT, WITH 3-1/C NO. 4 AND 1-1/C NO. 6 GROUND, 600V (EPR-TYPE RHW), 30MM DIA., POLYETHYLENE (CKTS. CL-A/B & CL-C/D ONLY).
5. POLES SETBACK ARE MEASURED FROM BACK OF THE CURB.

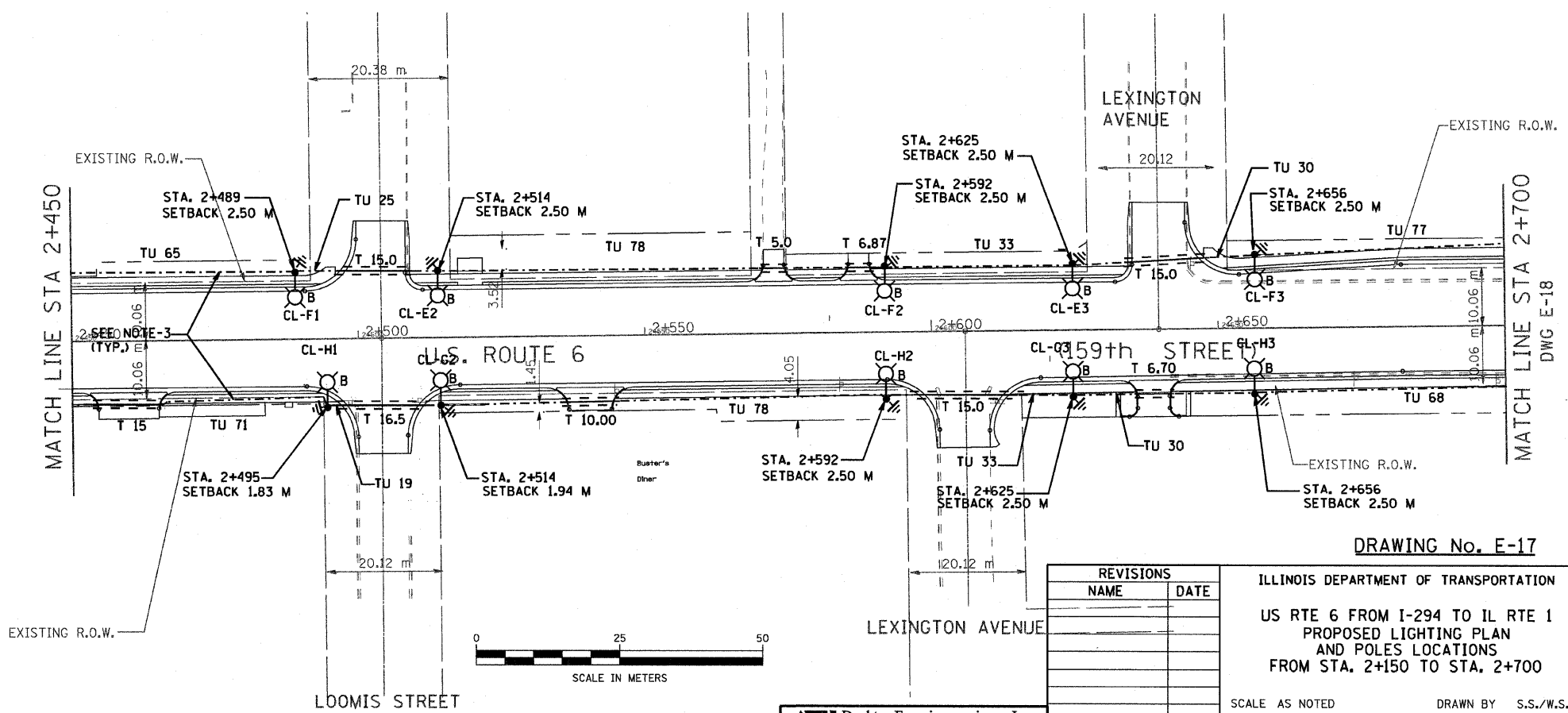
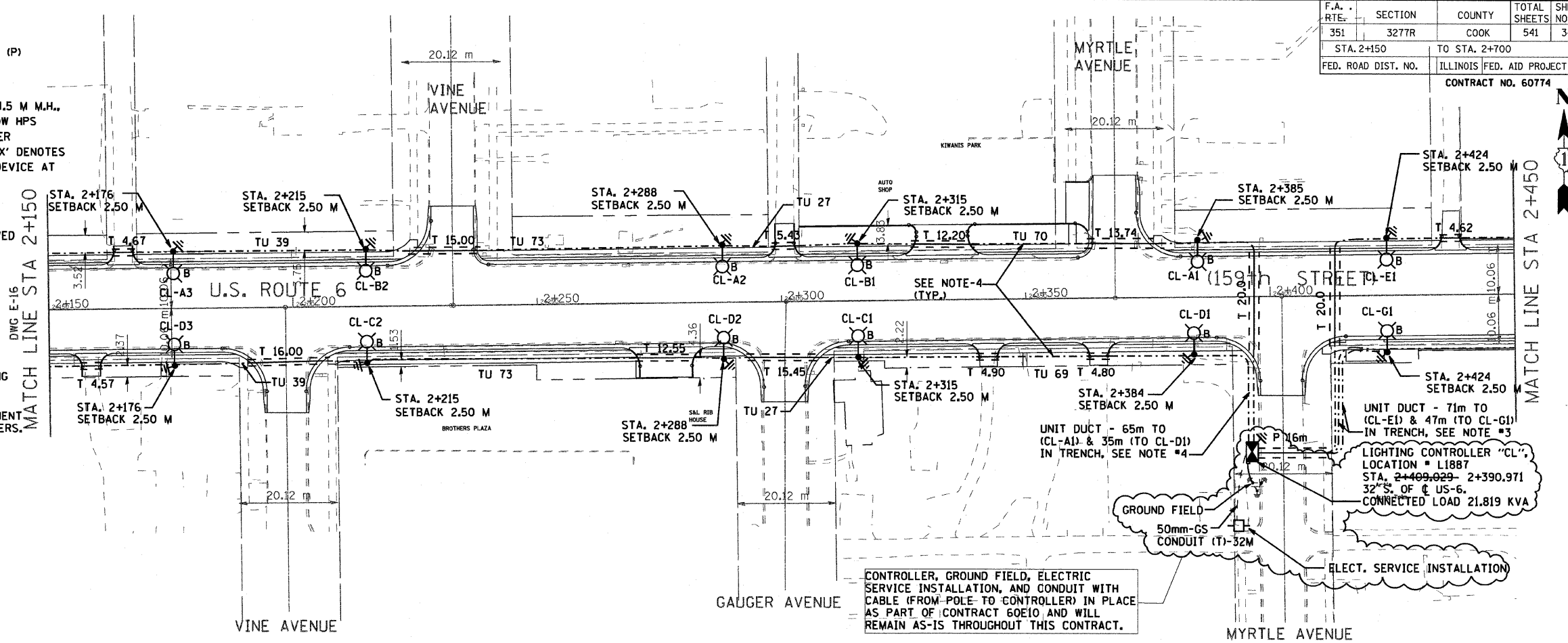

REVISIONS	
NAME	DATE

ILLINOIS DEPARTMENT OF TRANSPORTATION
 US RTE 6 FROM I-294 TO IL RTE 1
 PROPOSED LIGHTING PLAN
 AND POLES LOCATIONS
 FROM STA. 2+150 TO STA. 2+700

SCALE AS NOTED
 DATE 01/28/09

DRAWN BY S.S./W.S.
 CHECKED BY C.K./H.S.

F.A. RTE.	SECTION	COUNTY	TOTAL SHEETS	SHEET NO.
351	327TR	COOK	541	348
STA. 2+700		TO STA. 3+250		
FED. ROAD DIST. NO.		ILLINOIS FED. AID PROJECT		
CONTRACT NO. 60774				

LEGEND

- TI XX GALVANIZED STEEL CONDUIT IN TRENCH (T) UNDER DRIVEWAYS/PAVEMENT 65MM, XX DENOTES LENGTH IN METERS.
- CH-AX PROPOSED ALUMINUM LIGHT POLE (14.5 M M.H., 2.5M MAST ARM), FOUNDATION & 310W HPS LUMINAIRE. 'CH' DENOTES CONTROLLER NO. 'A' DENOTES CIRCUIT NUMBER. 'X' DENOTES POLE NO. 'B' DENOTES BREAKAWAY DEVICE AT THE POLE BASE.
- UNDER GROUND SERVICE 50mm GALVANIZED STEEL
- EXISTING CONTROLLER TO BE REMOVED AT COMPLETION OF PROJECT
- PROPOSED CONTROLLER
- GS GALVANIZED STEEL
- TU XX TU DENOTES UNIT DUCT IN TRENCH, SIZES AS NOTED ON PLANS, XX-DENOTES LENGTH IN METERS.
- GROUND ROD, 16MM DIA, X 3.0M LONG
- T XX GALVANIZED STEEL CONDUIT IN TRENCH (T) UNDER DRIVEWAYS/PAVEMENT 50MM, XX DENOTES LENGTH IN METERS.
- TEMPORARY WOOD POLE TO BE REMOVED
- GROUND FIELD FOR CONTROLLERS. 2/0 AWG BARE COPPER WIRE
- STEEL COMBINATION MAST ARM ASSEMBLY AND POLE (BY TRAFFIC SIGNAL CONTRACTOR)

NOTES:

1. ALL DIMENSIONS ARE IN METERS.
2. REFER TO LIGHTING NOTES ON DRAWING E-1.
3. UNIT DUCT, WITH 3-1/C NO. 6 AND 1-1/C NO. 6 GROUND, 600V (EPR-TYPE RHW), 25MM DIA., POLYETHYLENE UNLESS OTHERWISE NOTED.
4. UNIT DUCT, WITH 3-1/C NO. 2 AND 1-1/C NO. 4 GROUND, 600V (EPR-TYPE RHW), 40MM DIA., POLYETHYLENE UNLESS OTHERWISE NOTED. (CKT CM-A/B & CM-C/D)
5. FOR UNDERPASS AND ROADWAY LIGHTING BETWEEN EAST END OF PARK AVENUE AND STATION 2+950 - SEE DWGS E-11 & E-12.
6. FOR LOCATION OF MAIN JUNCTION BOXES FEEDING UNDERPASS LIGHTS, SEE DWG. E-12.
7. LUMINAIRES ON THE COMBINATION MAST ARM ASSEMBLY SHALL BE FURNISHED, INSTALLED AND WIRED BY THE LIGHTING CONTRACTOR.
8. POLES SETBACK ARE MEASURED FROM BACK OF THE CURB.

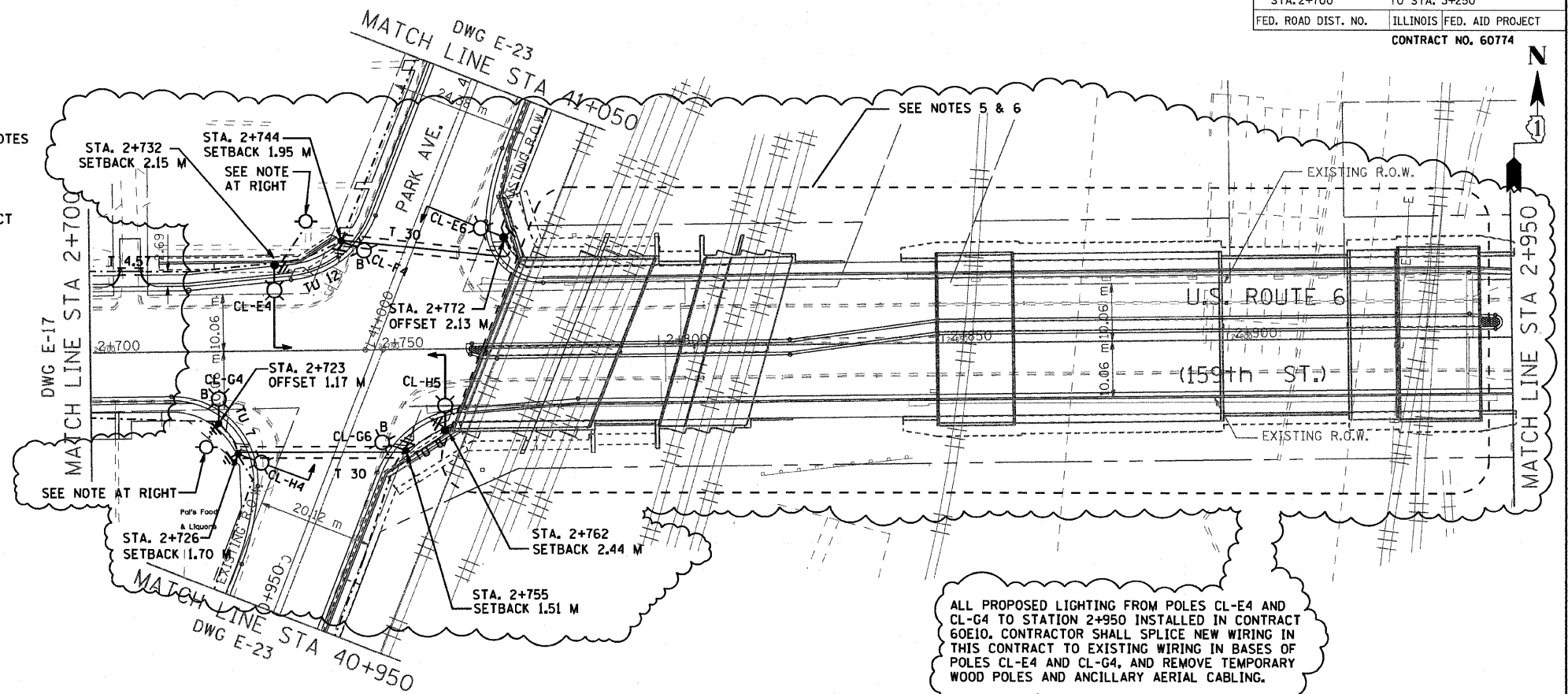

ALL PROPOSED LIGHTING FROM POLES CL-E4 AND CL-G4 TO STATION 2+950 INSTALLED IN CONTRACT 60E10. CONTRACTOR SHALL SPLICE NEW WIRING IN THIS CONTRACT TO EXISTING WIRING IN BASES OF POLES CL-E4 AND CL-G4, AND REMOVE TEMPORARY WOOD POLES AND ANCILLARY AERIAL CABLING.

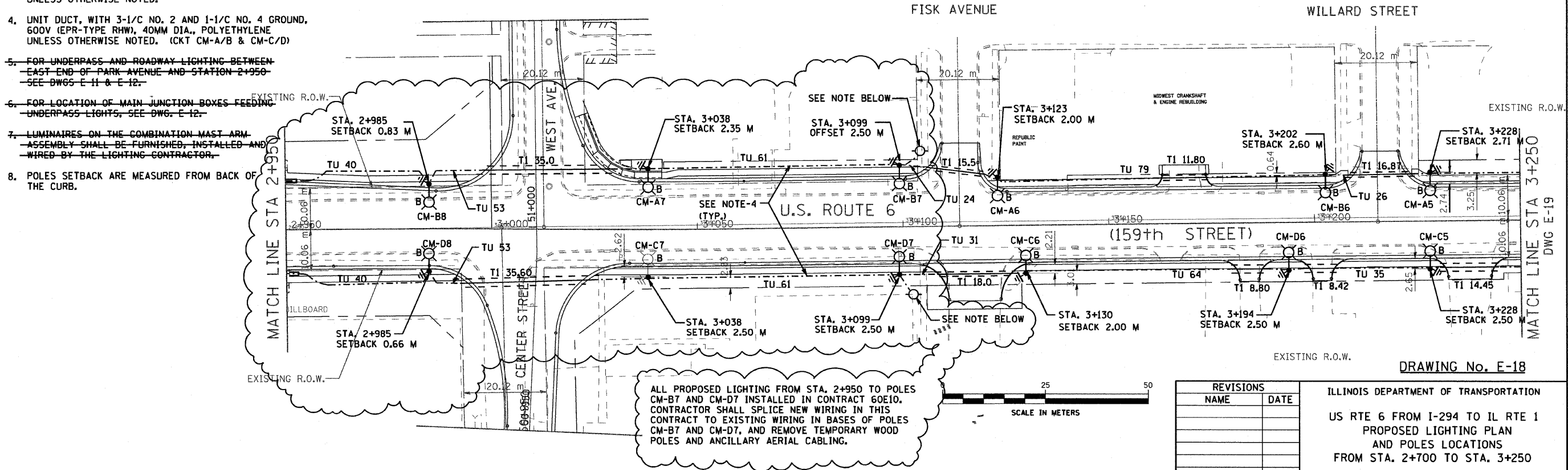

ALL PROPOSED LIGHTING FROM STA. 2+950 TO POLES CM-B7 AND CM-D7 INSTALLED IN CONTRACT 60E10. CONTRACTOR SHALL SPLICE NEW WIRING IN THIS CONTRACT TO EXISTING WIRING IN BASES OF POLES CM-B7 AND CM-D7, AND REMOVE TEMPORARY WOOD POLES AND ANCILLARY AERIAL CABLING.

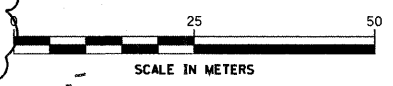

REVISIONS	
NAME	DATE

DRAWING No. E-18

ILLINOIS DEPARTMENT OF TRANSPORTATION

US RTE 6 FROM I-294 TO IL RTE 1
PROPOSED LIGHTING PLAN
AND POLES LOCATIONS
FROM STA. 2+700 TO STA. 3+250

SCALE AS NOTED DRAWN BY S.S./W.S.
DATE 01/28/09 CHECKED BY C.K./H.S.

LEGEND

- T1 XX GALVANIZED STEEL CONDUIT IN TRENCH (T) UNDER DRIVEWAYS/PAVEMENT 65MM, XX DENOTES LENGTH IN METERS.
- CH-AX PROPOSED ALUMINUM LIGHT POLE (14.5 M M.H., 2.5M MAST ARM), FOUNDATION & 310W HPS LUMINAIRE. 'CH' DENOTES CONTROLLER NO. 'A' DENOTES CIRCUIT NUMBER. 'X' DENOTES POLE NO. 'B' DENOTES BREAKAWAY DEVICE AT THE POLE BASE.
- UNDER GROUND SERVICE 50mm GALVANIZED STEEL
- EXISTING CONTROLLER TO BE REMOVED AT COMPLETION OF PROJECT
- PROPOSED CONTROLLER
- GS GALVANIZED STEEL
- TU XX TU DENOTES UNIT DUCT IN TRENCH, SIZES AS NOTED ON PLANS, XX-DENOTES LENGTH IN METERS.
- GROUND ROD, 16MM DIA, X 3.0M LONG
- T XX GALVANIZED STEEL CONDUIT IN TRENCH (T) UNDER DRIVEWAYS/PAVEMENT 50MM, XX DENOTES LENGTH IN METERS.
- GROUND FIELD FOR CONTROLLERS. 2/0 AWG BARE COPPER WIRE
- STEEL COMBINATION MAST ARM ASSEMBLY AND POLE. SEE DWG E-14. (BY TRAFFIC SIGNAL CONTRACTOR)

NOTES:

1. ALL DIMENSIONS ARE IN METERS.
2. REFER TO LIGHTING NOTES ON DRAWING E-1.
3. UNIT DUCT, WITH 3-1/2 NO. 6 AND 1-1/2 NO. 6 GROUND, 600V (EPR-TYPE RHW), 25MM DIA., POLYETHYLENE UNLESS OTHERWISE NOTED.
4. UNIT DUCT, WITH 3-1/2 NO. 2 AND 1-1/2 NO. 4 GROUND, 600V (EPR-TYPE RHW), 40MM DIA., POLYETHYLENE UNLESS OTHERWISE NOTED. (CKT CM-A/B & CM-C/D)
5. LUMINAIRE ON THE COMBINATION MAST ARM ASSEMBLY SHALL BE FURNISHED, INSTALLED AND WIRED BY THE LIGHTING CONTRACTOR.
6. POLES SETBACK ARE MEASURED FROM BACK OF THE CURB.
7. 65MM GALVANIZED STEEL CONDUIT USED IN CIRCUITS "A", "B", "C" AND "D", 50MM GALVANIZED STEEL CONDUIT USED IN CIRCUITS "E", "F", "G" AND "H".

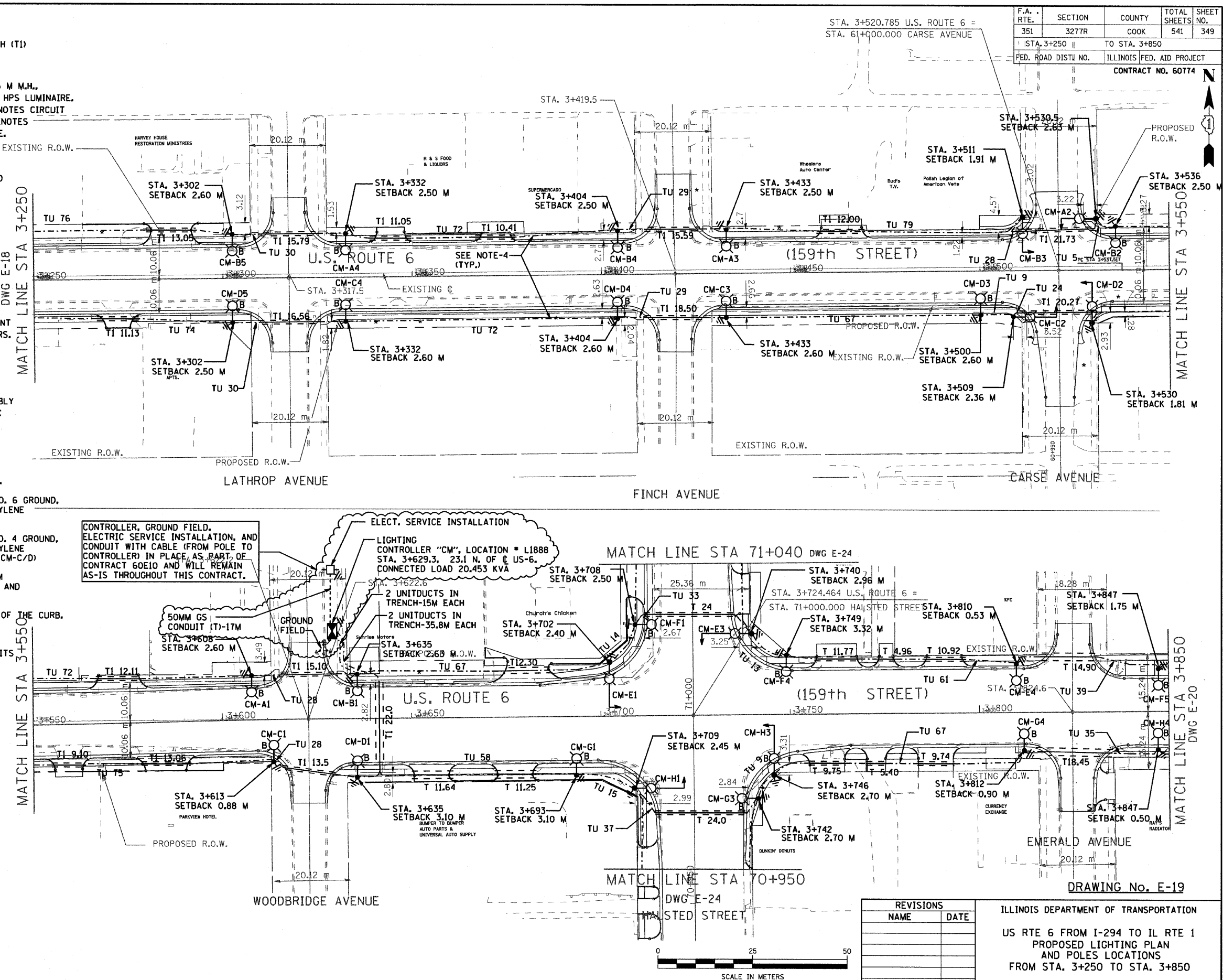

CONTROLLER, GROUND FIELD, ELECTRIC SERVICE INSTALLATION, LIGHTING CONTROLLER "CM", LOCATION = L1888 STA. 3+629.3, 23.1 N. OF U.S. 6. CONNECTED LOAD 20.453 KVA

2 UNITDUCTS IN TRENCH-15M EACH
2 UNITDUCTS IN TRENCH-35.8M EACH

50MM GS CONDUIT (T)-17M
GROUND FIELD

F.A. RTE.	SECTION	COUNTY	TOTAL SHEETS	SHEET NO.
351	3277R	COOK	541	349
STA. 3+250		TO STA. 3+850		
FED. ROAD DIST. NO.		ILLINOIS FED. AID PROJECT		
CONTRACT NO. 60774				

REVISIONS	
NAME	DATE

ILLINOIS DEPARTMENT OF TRANSPORTATION

US RTE 6 FROM I-294 TO IL RTE 1
PROPOSED LIGHTING PLAN
AND POLES LOCATIONS
FROM STA. 3+250 TO STA. 3+850

SCALE AS NOTED
DATE 01/28/09



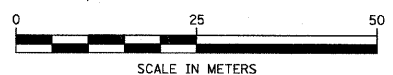

DRAWN BY S.S./W.S.
CHECKED BY C.K./H.S.

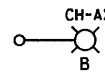

DRAWING No. E-19

F.A. RTE.	SECTION	COUNTY	TOTAL SHEETS	SHEET NO.
351	3277R	COOK	541	350
STA. 3+850		TO STA. 3+973		
FED. ROAD DIST. NO.		ILLINOIS FED. AID PROJECT		
CONTRACT NO. 60774				

LEGEND

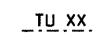
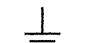
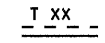
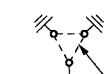
-  PROPOSED ALUMINUM LIGHT POLE (14.5 M M.H., 2.5M MAST ARM), FOUNDATION & 310W HPS LUMINAIRE. 'CH' DENOTES CONTROLLER NO. 'A' DENOTES CIRCUIT NUMBER. 'X' DENOTES POLE NO. 'B' DENOTES BREAKAWAY DEVICE AT THE POLE BASE.
-  UNDER GROUND SERVICE 50mm GALVANIZED STEEL
-  EXISTING CONTROLLER TO BE REMOVED AT COMPLETION OF PROJECT
-  PROPOSED CONTROLLER
- GS GALVANIZED STEEL
-  TU DENOTES UNIT DUCT IN TRENCH, SIZES AS NOTED ON PLANS, XX-DENOTES LENGTH IN METERS.
-  GROUND ROD, 16MM DIA, X 3.0M LONG
-  GALVANIZED STEEL CONDUIT IN TRENCH (T) UNDER DRIVEWAYS/PAVEMENT 50MM, XX DENOTES LENGTH IN METERS.
-  GROUND FIELD FOR CONTROLLERS. 2/0 AWG BARE COPPER WIRE

NOTES:

1. ALL DIMENSIONS ARE IN METERS.
2. REFER TO LIGHTING NOTES ON DRAWING ON E-1.
3. UNIT DUCT, WITH 3-1/C NO. 6 AND 1-1/C NO. 6 GROUND, 600V (EPR-TYPE RHW), 25MM DIA., POLYETHYLENE UNLESS OTHERWISE NOTED.
4. POLES SETBACK ARE MEASURED FROM BACK OF THE CURB.

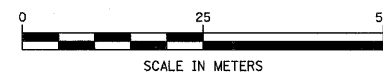
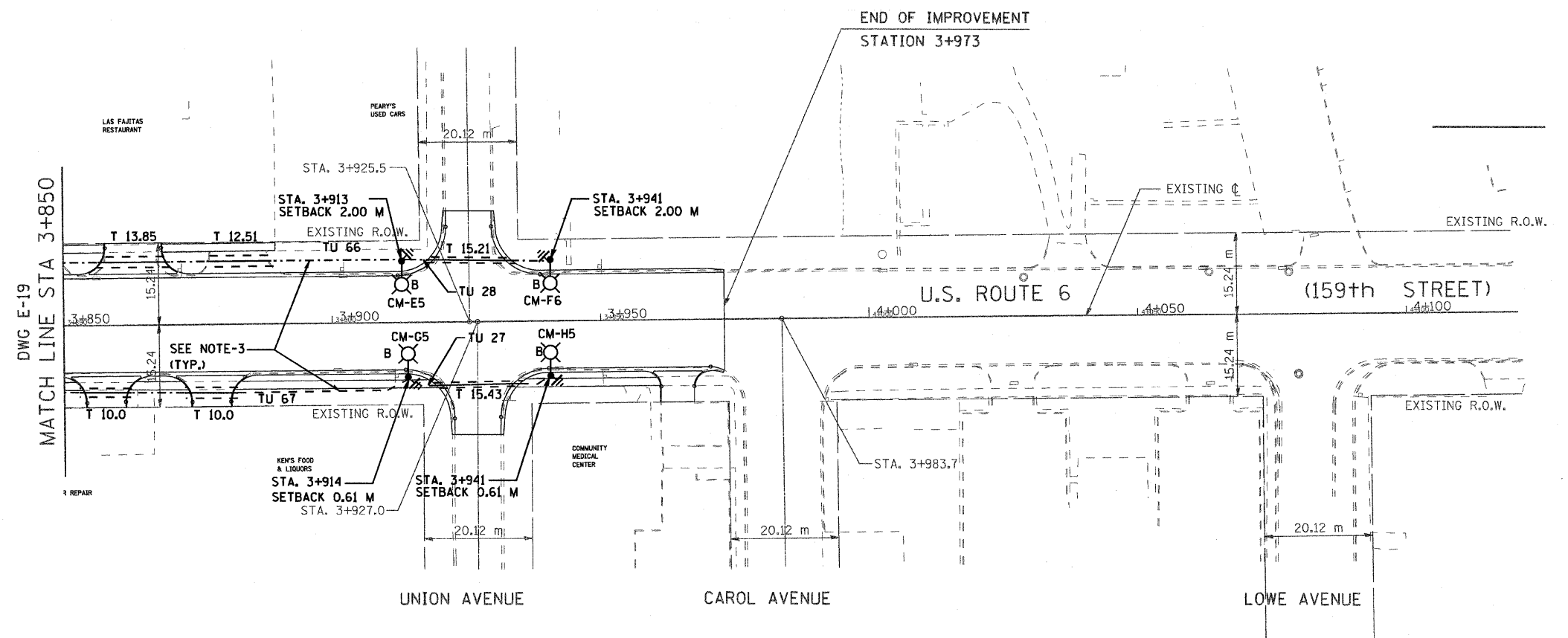

Delta Engineering, Inc.
CONSULTING ENGINEERS, CHICAGO, ILLINOIS.

REVISIONS	
NAME	DATE

DRAWING No. E-20

ILLINOIS DEPARTMENT OF TRANSPORTATION
 US RTE 6 FROM I-294 TO IL RTE 1
 PROPOSED LIGHTING PLAN
 AND POLES LOCATIONS
 FROM STA. 3+850 TO STA. 3+973
 SCALE AS NOTED DRAWN BY S.S./W.S.
 DATE 01/28/09 CHECKED BY C.K./H.S.

F.A. RTE.	SECTION	COUNTY	TOTAL SHEETS	SHEET NO.
351	3277R	COOK	541	351
STA. 10+785		TO STA. 11+100		
FED. ROAD DIST. NO.		ILLINOIS FED. AID PROJECT		
CONTRACT NO. 60774				



LEGEND

- PROPOSED ALUMINUM LIGHT POLE (14.5 M M.H., 2.5M MAST ARM), FOUNDATION & 310W HPS LUMINAIRE. 'CH' DENOTES CONTROLLER NO. 'A' DENOTES CIRCUIT NUMBER. 'X' DENOTES POLE NO. 'B' DENOTES BREAKAWAY DEVICE AT THE POLE BASE.
- UNDER GROUND SERVICE 50mm GALVANIZED STEEL
- EXISTING CONTROLLER TO BE REMOVED AT COMPLETION OF PROJECT
- PROPOSED CONTROLLER
- GALVANIZED STEEL
- TU DENOTES UNIT DUCT IN TRENCH, SIZES AS NOTED ON PLANS, XX-DENOTES LENGTH IN METERS.
- GROUND ROD, 16MM DIA, X 3.0M LONG
- T DENOTES GALVANIZED STEEL CONDUIT IN TRENCH (T) UNDER DRIVEWAYS/PAVEMENT 50MM, XX DENOTES LENGTH IN METERS.
- GROUND FIELD FOR CONTROLLERS. 2/0 AWG BARE COPPER WIRE
- EXISTING LIGHTING POLE TO REMAIN

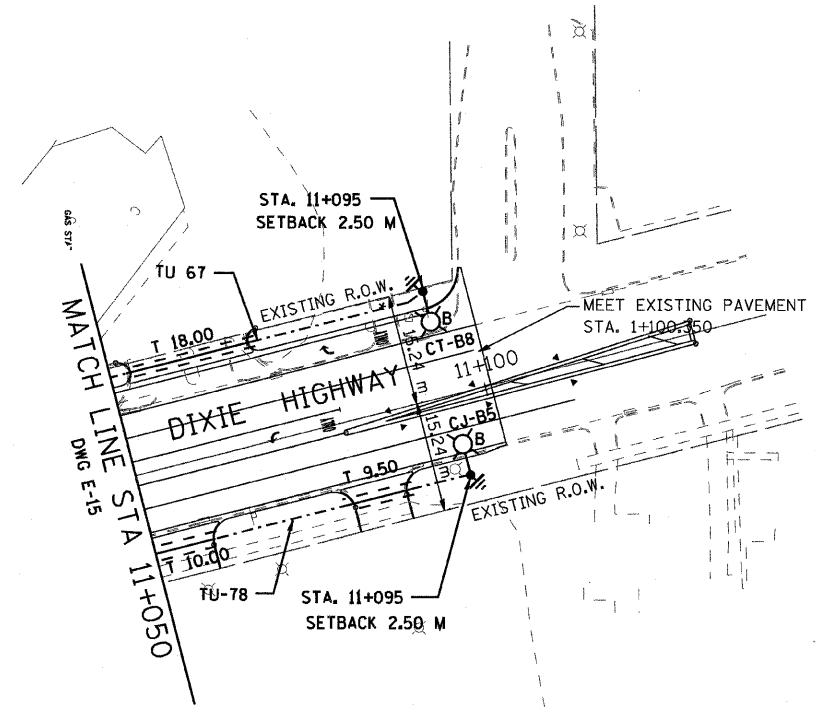
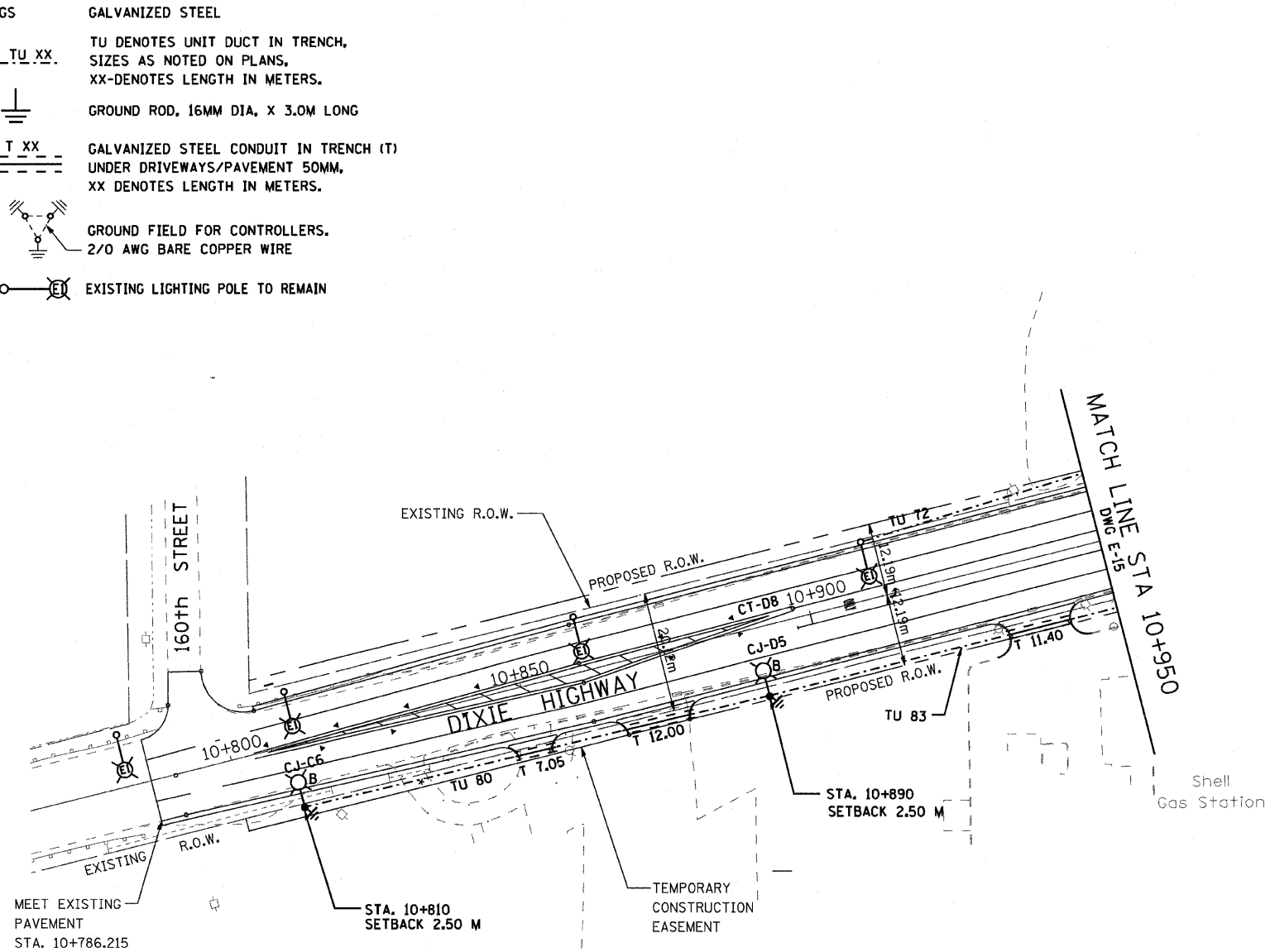

- NOTES:**
1. ALL DIMENSIONS ARE IN METERS.
 2. REFER TO LIGHTING NOTES ON DRAWING ON E-1.
 3. UNIT DUCT, WITH 3-1/2" NO. 6 AND 1-1/2" NO. 6 GROUND, 600V (EPR-TYPE RHW), 25MM DIA., POLYETHYLENE UNLESS OTHERWISE NOTED.
 4. POLES SETBACK ARE MEASURED FROM BACK OF THE CURB.

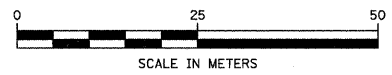

Delta Engineering, Inc.
CONSULTING ENGINEERS, CHICAGO, ILLINOIS

DRAWING No. E-21

REVISIONS	
NAME	DATE









ILLINOIS DEPARTMENT OF TRANSPORTATION
US RTE 6 FROM I-294 TO IL RTE 1
PROPOSED LIGHTING PLAN
AND POLE LOCATIONS
STA. 10+785 TO STA. 11+100

SCALE AS NOTED
DATE 01/28/09

DRAWN BY S.S./W.S.
CHECKED BY C.K./H.S.

F.A. RTE.	SECTION	COUNTY	TOTAL SHEETS	SHEET NO.
351	327TR	COOK	541	352
STA. 20+850		TO STA. 21+100		
FED. ROAD DIST. NO.		ILLINOIS FED. AID PROJECT		CONTRACT NO. 60774

LEGEND

-  GALVANIZED STEEL CONDUIT PUSHED (P)
UNDER DRIVEWAYS/PAVEMENT 65MM,
XX DENOTES LENGTH IN METERS.
-  PROPOSED ALUMINUM LIGHT POLE (14.5 M M.H.,
2.5M MAST ARM, FOUNDATION & 310W HPS LUMINAIRE.
'CH' DENOTES CONTROLLER NO. 'A' DENOTES CIRCUIT
NUMBER. 'X' DENOTES POLE NO. 'B' DENOTES
BREAKAWAY DEVICE AT THE POLE BASE.
-  UNDER GROUND SERVICE 50mm
GALVANIZED STEEL
-  EXISTING CONTROLLER TO BE REMOVED
AT COMPLETION OF PROJECT
-  PROPOSED CONTROLLER
- GS GALVANIZED STEEL
-  TU XX
TU DENOTES UNIT DUCT IN TRENCH,
SIZES AS NOTED ON PLANS,
XX-DENOTES LENGTH IN METERS.
-  GROUND ROD, 16MM DIA, X 3.0M LONG
-  T XX
GALVANIZED STEEL CONDUIT IN TRENCH (T)
UNDER DRIVEWAYS/PAVEMENT 50MM,
XX DENOTES LENGTH IN METERS.
-  GROUND FIELD FOR CONTROLLERS,
2/0 AWG BARE COPPER WIRE

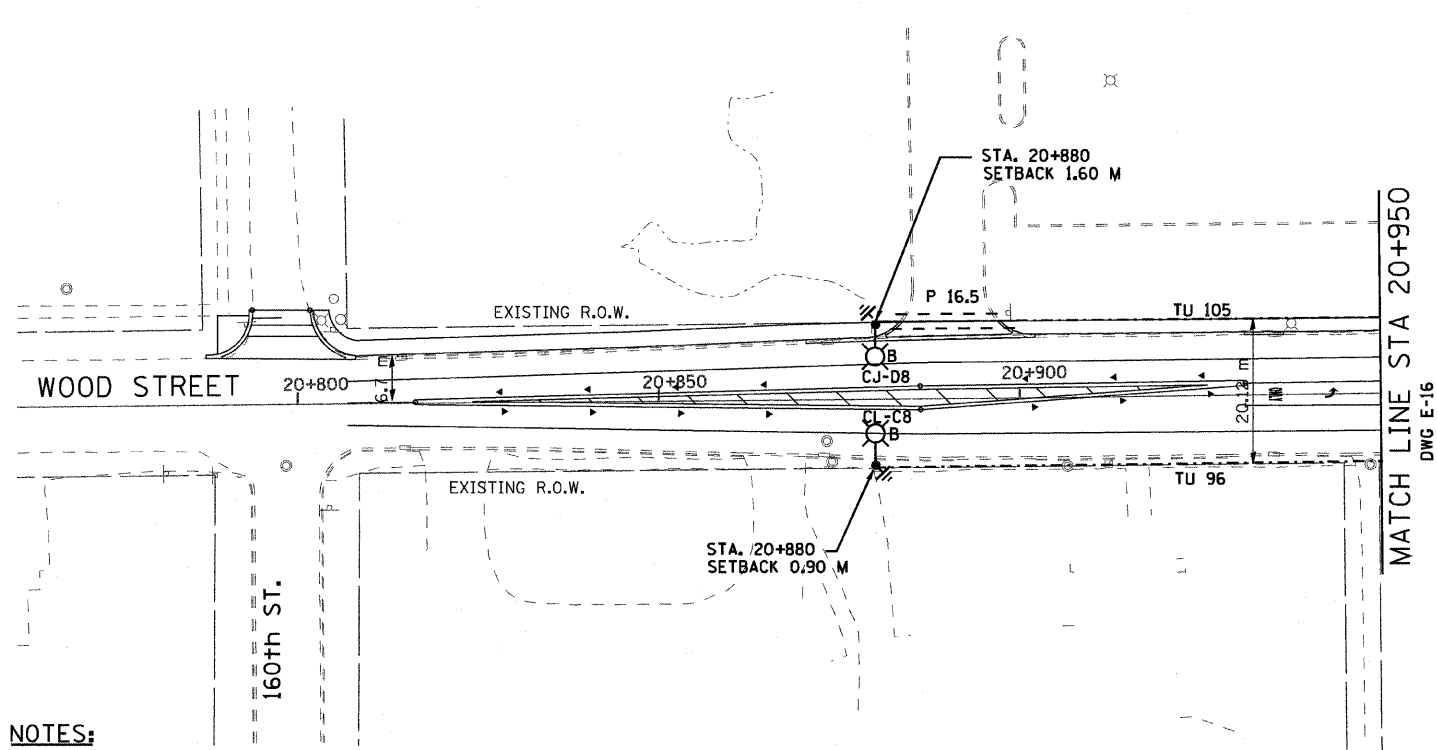
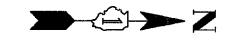

AMOCO
Gas Station

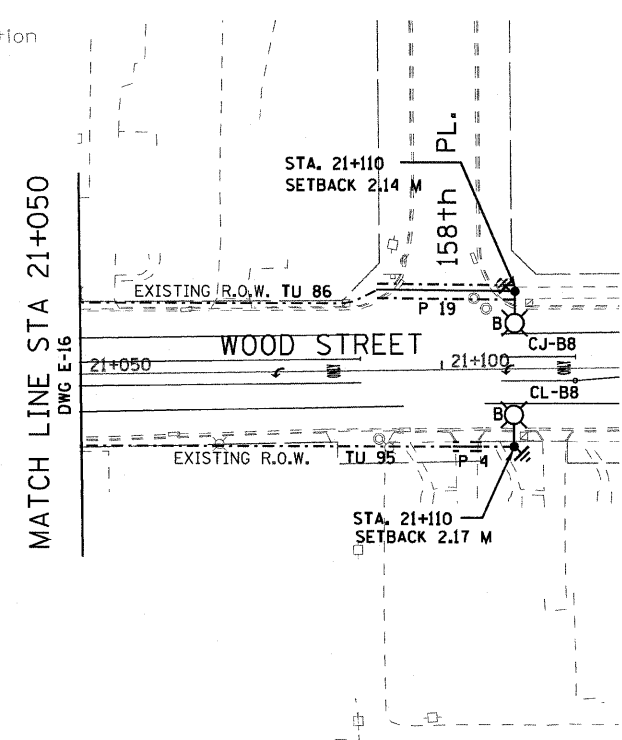

NOTES:

1. ALL DIMENSIONS ARE IN METERS.
2. REFER TO LIGHTING NOTES ON DRAWING ON E-1.
3. UNIT DUCT, WITH 3-1/C NO. 6 AND 1-1/C NO. 6 GROUND, 600V (EPR-TYPE RHW), 25MM DIA., POLYETHYLENE UNLESS OTHERWISE NOTED.
4. POLES SETBACK ARE MEASURED FROM BACK OF THE CURB.

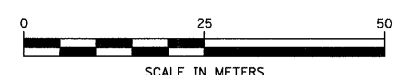

Delta Engineering, Inc.
CONSULTING ENGINEERS, CHICAGO ILLINOIS.

REVISIONS	
NAME	DATE

ILLINOIS DEPARTMENT OF TRANSPORTATION
US RTE 6 FROM I-294 TO IL RTE 1
PROPOSED LIGHTING PLAN
AND POLE LOCATIONS
STA. 20+850 TO STA. 21+100







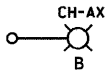
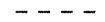

SCALE AS NOTED
DATE 01/28/09

DRAWN BY S.S./W.S.
CHECKED BY C.K./H.S.

DRAWING No. E-22

F.A. RTE.	SECTION	COUNTY	TOTAL SHEETS	SHEET NO.
351	3277R	COOK	541	353
STA. 70+880		TO STA. 71+200		
FED. ROAD DIST. NO.		ILLINOIS FED. AID PROJECT		
CONTRACT NO. 60774				

LEGENDS

- 
 PROPOSED ALUMINUM LIGHT POLE (14.5 M M.H., 2.5M MAST ARM), FOUNDATION & 310W HPS LUMINAIRE. 'CH' DENOTES CONTROLLER NO., 'A' DENOTES CIRCUIT NUMBER, 'X' DENOTES POLE NO., 'B' DENOTES BREAKAWAY DEVICE AT THE POLE BASE.
- 
 UNDER GROUND SERVICE 50mm GALVANIZED STEEL
- 
 EXISTING CONTROLLER TO BE REMOVED AT COMPLETION OF PROJECT
- 
 PROPOSED CONTROLLER
- 
 GALVANIZED STEEL
- 
 TU DENOTES UNIT DUCT IN TRENCH, SIZES AS NOTED ON PLANS, XX-DENOTES LENGTH IN METERS.
- 
 GROUND ROD, 16MM DIA, X 3.0M LONG
- 
 GALVANIZED STEEL CONDUIT IN TRENCH (T) UNDER DRIVEWAYS/PAVEMENT 50MM, XX DENOTES LENGTH IN METERS.
- 
 GROUND FIELD FOR CONTROLLERS. 2/0 AWG BARE COPPER WIRE

NOTES:

1. ALL DIMENSIONS ARE IN METERS.
2. REFER TO LIGHTING NOTES ON DRAWING ON E-1.
3. UNIT DUCT, WITH 3-1/2 NO. 6 AND 1-1/2 NO. 6 GROUND, 600V (EPR-TYPE RHW), 25MM DIA., POLYETHYLENE UNLESS OTHERWISE NOTED.
4. POLES SETBACK ARE MEASURED FROM BACK OF THE CURB.

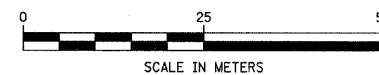
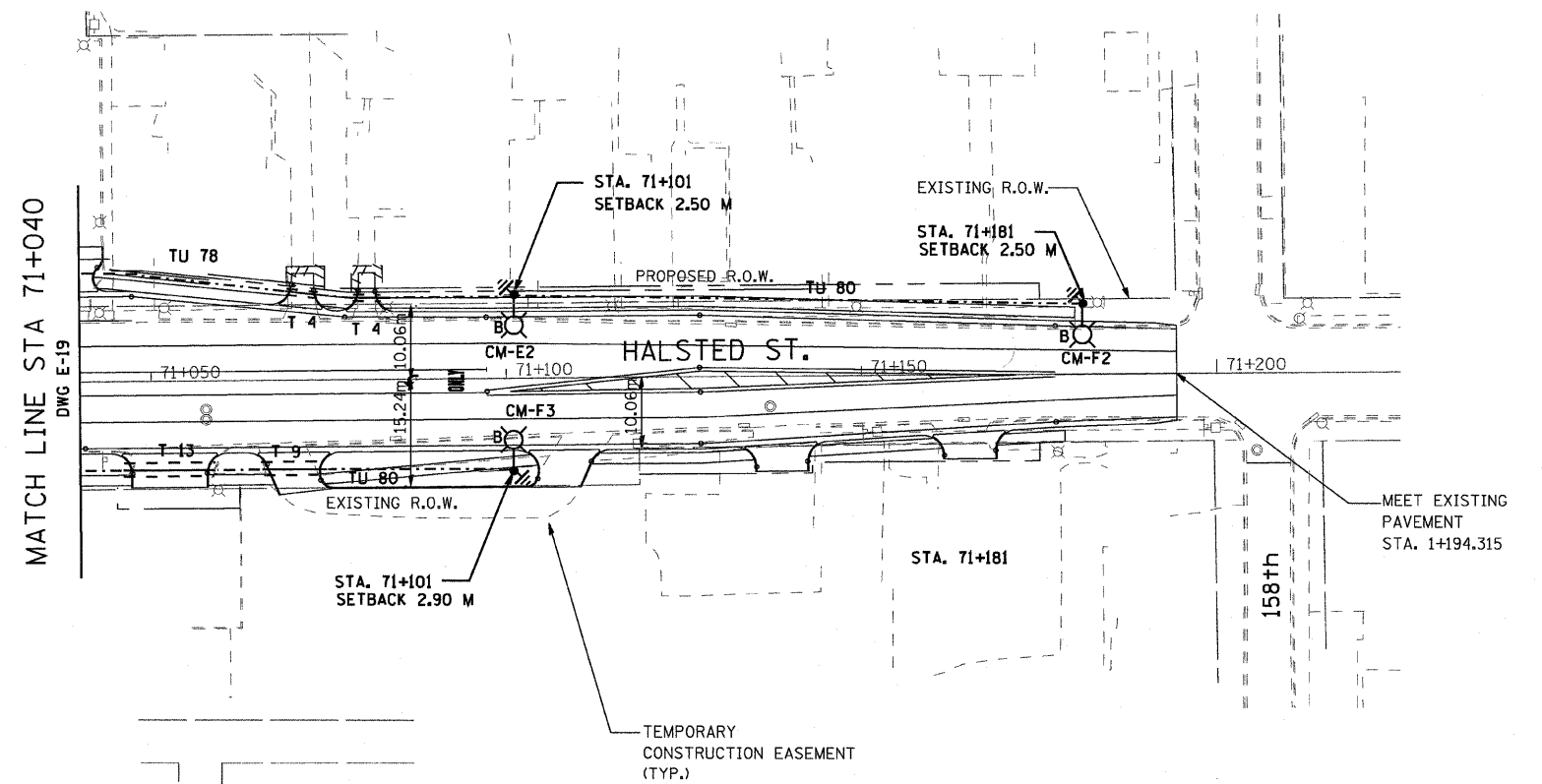
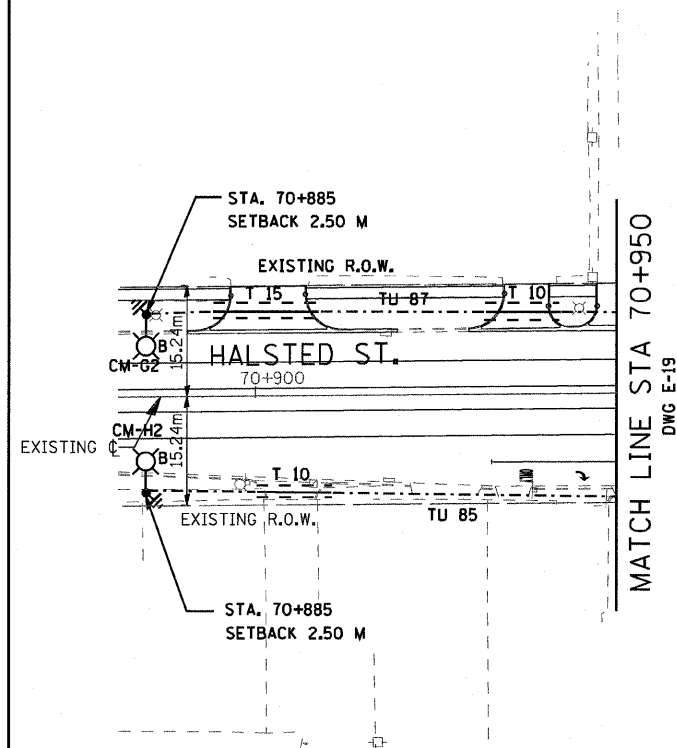

Delta Engineering, Inc.
CONSULTING ENGINEERS, CHICAGO ILLINOIS.

DRAWING No. E-24

REVISIONS	
NAME	DATE

ILLINOIS DEPARTMENT OF TRANSPORTATION
US RTE 6 FROM I-294 TO IL RTE 1
PROPOSED LIGHTING PLAN
AND POLE LOCATIONS
STA. 70+880 TO STA. 71+200
SCALE AS NOTED DRAWN BY S.S./W.S.
DATE 01/28/09 CHECKED BY C.K./H.S.

F.A. RTE.	SECTION	COUNTY	TOTAL SHEETS NO.	SHEET NO.
351	3277R	COOK	541	354
STA.		TO STA.		
FED. ROAD DIST. NO.		ILLINOIS FED. AID PROJECT		
		CONTRACT NO. 60774		

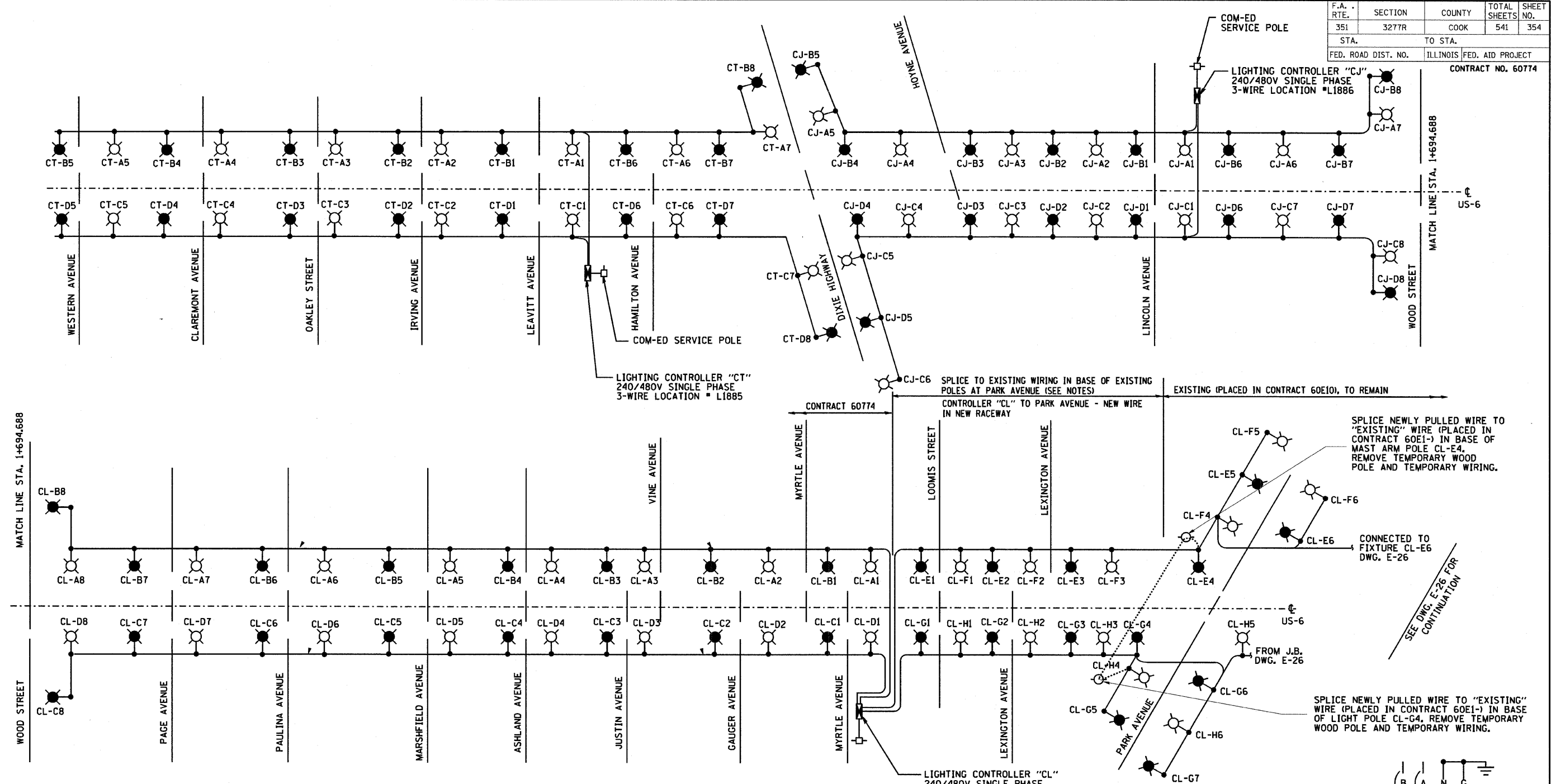

LOAD TABULATION FOR LIGHTING CONTROLLER "CT"

CIRCUIT	LAMP LOAD	TOTAL LOAD	AMPS
A (240V)	7 @ 310 W HPS	2387	9.95
B (240V)	8 @ 310 W HPS	2728	11.37
C (240V)	7 @ 310 W HPS	2387	9.95
D (240V)	8 @ 310 W HPS	2728	11.37
(480V)	TOTAL VA	10230	21.31

LOAD TABULATION FOR LIGHTING CONTROLLER "CL"

CIRCUIT	LAMP LOAD	TOTAL LOAD	AMPS
A (240V)	8 @ 310 W HPS	2728	11.37
B (240V)	8 @ 310 W HPS	2728	11.37
C (240V)	8 @ 310 W HPS	2728	11.37
D (240V)	8 @ 310 W HPS	2728	11.37
E (240V)	6 @ 310 W HPS 5 @ 70 W HPS	2471	10.29
F (240V)	7 @ 310 W HPS 5 @ 70 W HPS	2812	11.71
G (240V)	7 @ 310 W HPS 5 @ 70 W HPS	2812	11.71
H (240V)	7 @ 310 W HPS 5 @ 70 W HPS	2812	11.71
(480V)	TOTAL VA	21819	45.45

LOAD TABULATION FOR LIGHTING CONTROLLER "CJ"

CIRCUIT	LAMP LOAD	TOTAL LOAD	AMPS
A (240V)	7 @ 310 W HPS	2387	9.95
B (240V)	8 @ 310 W HPS	2728	11.37
C (240V)	8 @ 310 W HPS	2728	11.37
D (240V)	8 @ 310 W HPS	2728	11.37
(480V)	TOTAL VA	10571	22.02

LEGEND:

- ⊠ 310 HPS M-C 111 LUMINAIRE ON RED CABLE
- ⊠ 310 HPS M-C 111 LUMINAIRE ON BLACK CABLE
- PROPOSED LIGHTING CONTROLLER
- ⊕ ComEd SERVICE POLE
- TEMPORARY WOOD POLE (TO BE REMOVED)

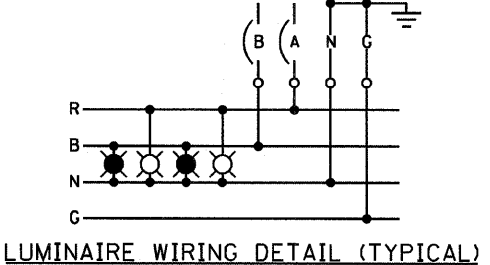

DRAWING No. E-25

REVISIONS	
NAME	DATE

ILLINOIS DEPARTMENT OF TRANSPORTATION
 US RTE 6 FROM I-294 TO IL RTE 1
 SINGLE LINE DIAGRAM
 PROPOSED LIGHTING
 SHEET '1' OF '2'
 SCALE AS NOTED
 DATE 01/28/09
 DRAWN BY S.S./W.S.
 CHECKED BY C.K./H.S.

F.A. RTE.	SECTION	COUNTY	TOTAL SHEETS NO.	SHEET NO.
351	3277R	COOK	541	355
STA. 3+450		TO STA.		
FED. ROAD DIST. NO.		ILLINOIS	FED. AID PROJECT	
		CONTRACT NO. 60774		

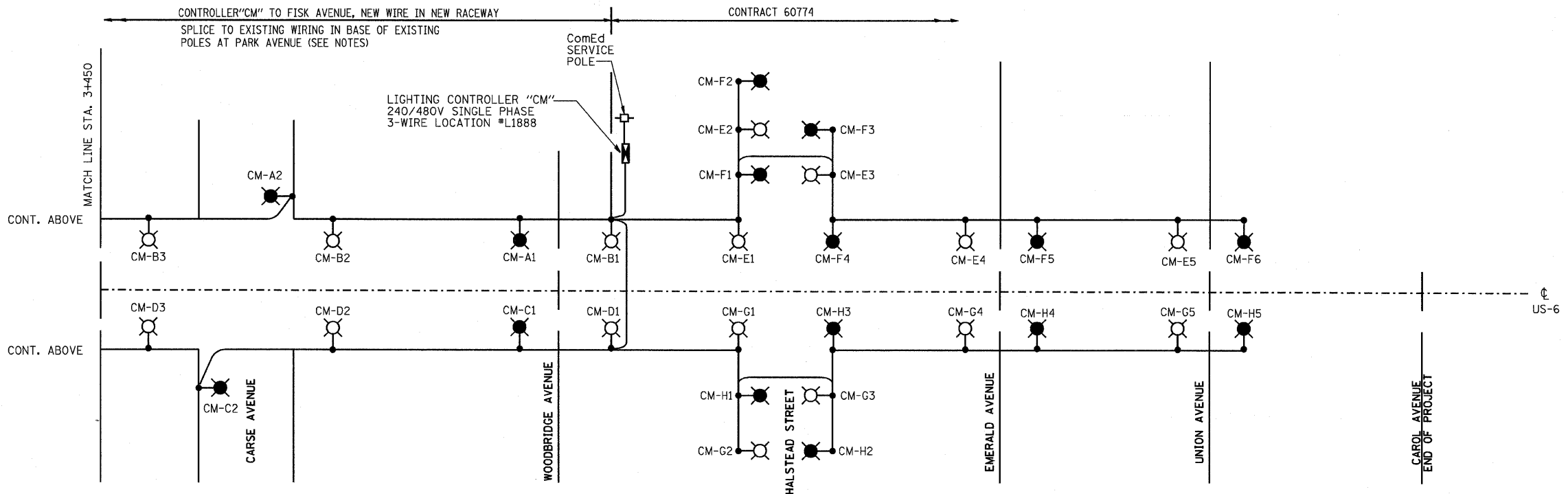
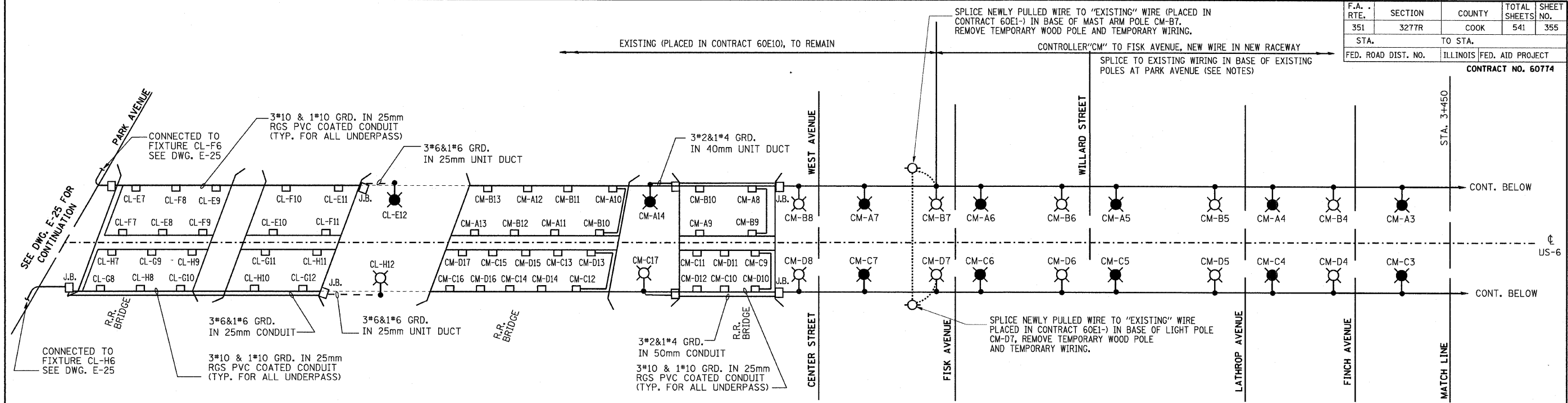

LOAD TABULATION FOR LIGHTING CONTROLLER "CM"

CIRCUIT	LAMP LOAD	TOTAL LOAD	AMPS
A (240V)	8 @ 310 W HPS	3238	13.50
	6 @ 70 W HPS		
B (240V)	8 @ 310 W HPS	3238	13.50
	6 @ 70 W HPS		
C (240V)	8 @ 310 W HPS	3408	14.20
	6 @ 70 W HPS		
D (240V)	8 @ 310 W HPS	3408	14.20
	6 @ 70 W HPS		
E (240V)	5 @ 310 W HPS	1705	7.10
F (240V)	6 @ 310 W HPS	2046	8.53
G (240V)	5 @ 310 W HPS	1705	7.10
H (240V)	5 @ 310 W HPS	1705	7.10
(480V)	TOTAL VA	20453	42.61

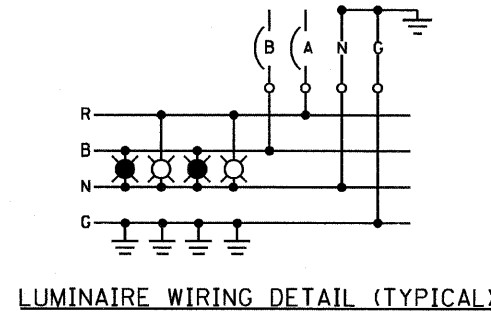

- LEGEND:
- 310 HPS M-C 111 LUMINAIRE ON RED CABLE
 - 310 HPS M-C 111 LUMINAIRE ON BLACK CABLE
 - PROPOSED LIGHTING CONTROLLER
 - ComEd SERVICE POLE
 - TEMPORARY WOOD POLE (TO BE REMOVED)

REVISIONS	
NAME	DATE

DRAWING No. E-26

ILLINOIS DEPARTMENT OF TRANSPORTATION

US RTE 6 FROM I-294 TO IL RTE 1

SINGLE LINE DIAGRAM
PROPOSED LIGHTING
SHEET '2' OF '2'

SCALE AS NOTED

DATE 01/28/09

DRAWN BY S.S./W.S.

CHECKED BY C.K./H.S.

F.A. RTE.	SECTION	COUNTY	TOTAL SHEETS NO.	SHEET NO.
351	3277R	COOK	541	356
STA.		TO STA.		
FED. ROAD DIST. NO.		ILLINOIS FED. AID PROJECT		
CONTRACT NO. 60774				

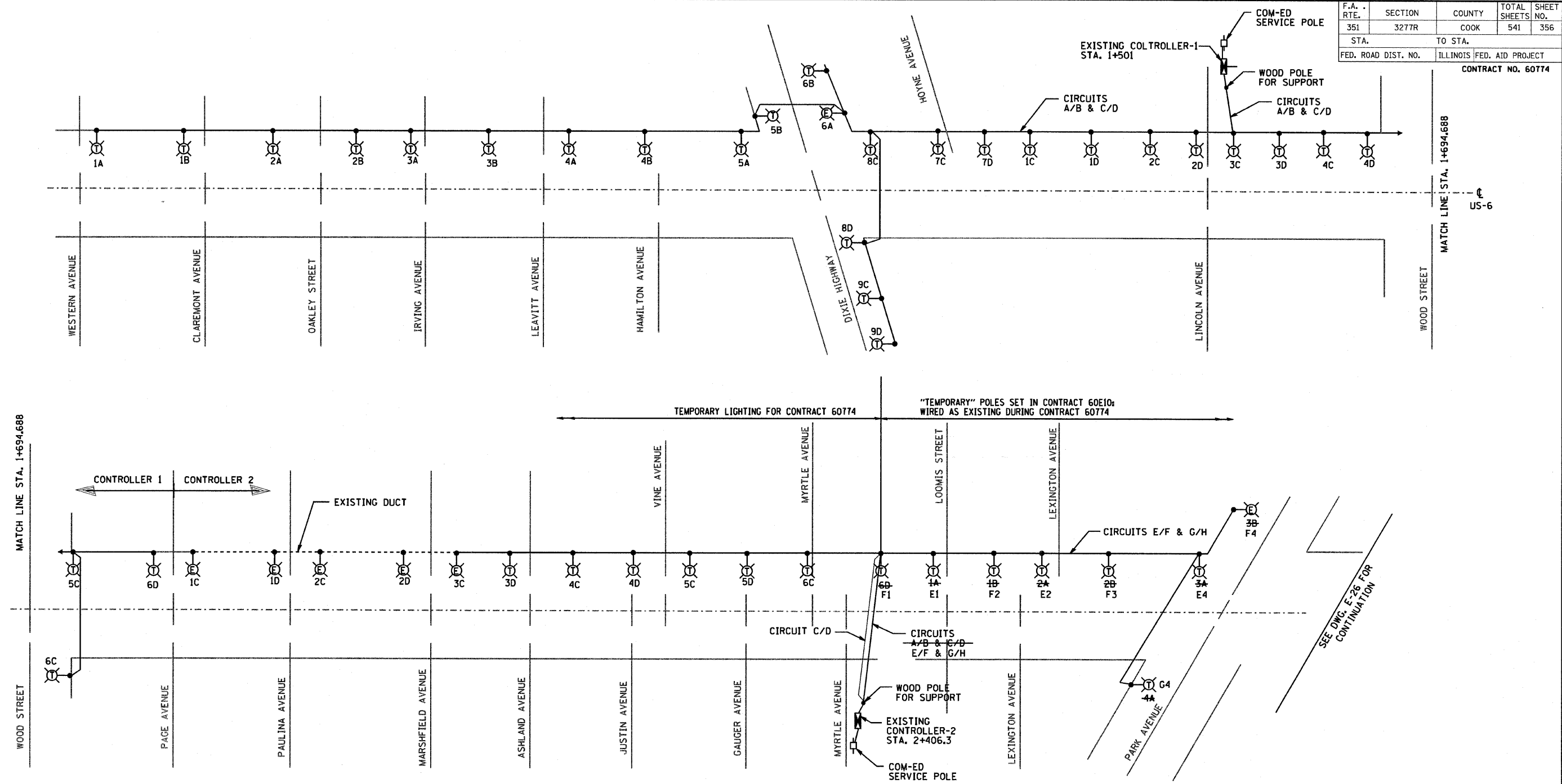

LOAD TABLE

CONTROLLER 1		
CIRCUIT NO.	LOAD	CURRENT
A	2740W	11.41A
B	2800W	11.66A
C	4640W	19.33
D	4165W	17.35A

CONTROLLER 2		
CIRCUIT NO.	LOAD	CURRENT
A	1900W	7.91A
B	1425W	5.93A
C	2520W	10.5A
D	3105W	12.93A

LEGEND:

- LIGHT POLE, WOOD, WITH 14.5 M MAST ARM
- EXISTING LIGHT POLE
- EXISTING LIGHTING CONTROLLER
- ComEd SERVICE POLE
- LIGHT POLE, WOOD, FOR SUPPORT

REVISIONS	
NAME	DATE

DRAWING No. E-27

ILLINOIS DEPARTMENT OF TRANSPORTATION
US RTE 6 FROM I-294 TO IL RTE 1
SINGLE LINE DIAGRAM
TEMPORARY LIGHTING
SHEET '1' OF '2'

DRAWN BY S.S./W.S.
CHECKED BY C.K./H.S.

DATE 01/28/09

F.A. RTE.	SECTION	COUNTY	TOTAL SHEETS	SHEET NO.
351	3277R	COOK	541	357
STA.		TO STA.		
FED. ROAD DIST. NO.		ILLINOIS FED. AID PROJECT		

CONTRACT NO. 60774

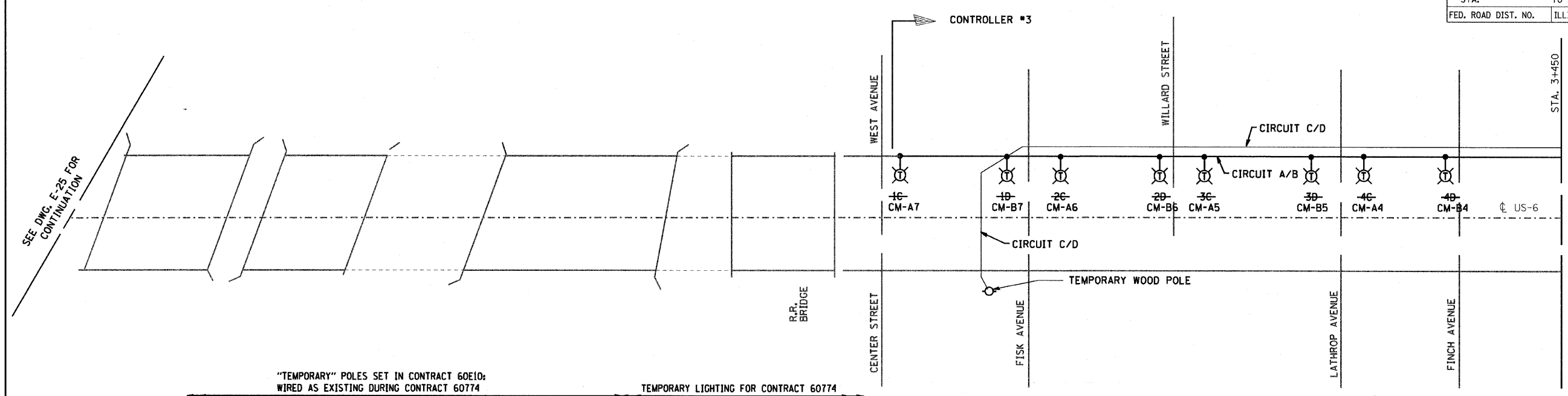

"TEMPORARY" POLES SET IN CONTRACT 60E10; WIRED AS EXISTING DURING CONTRACT 60774

TEMPORARY LIGHTING FOR CONTRACT 60774

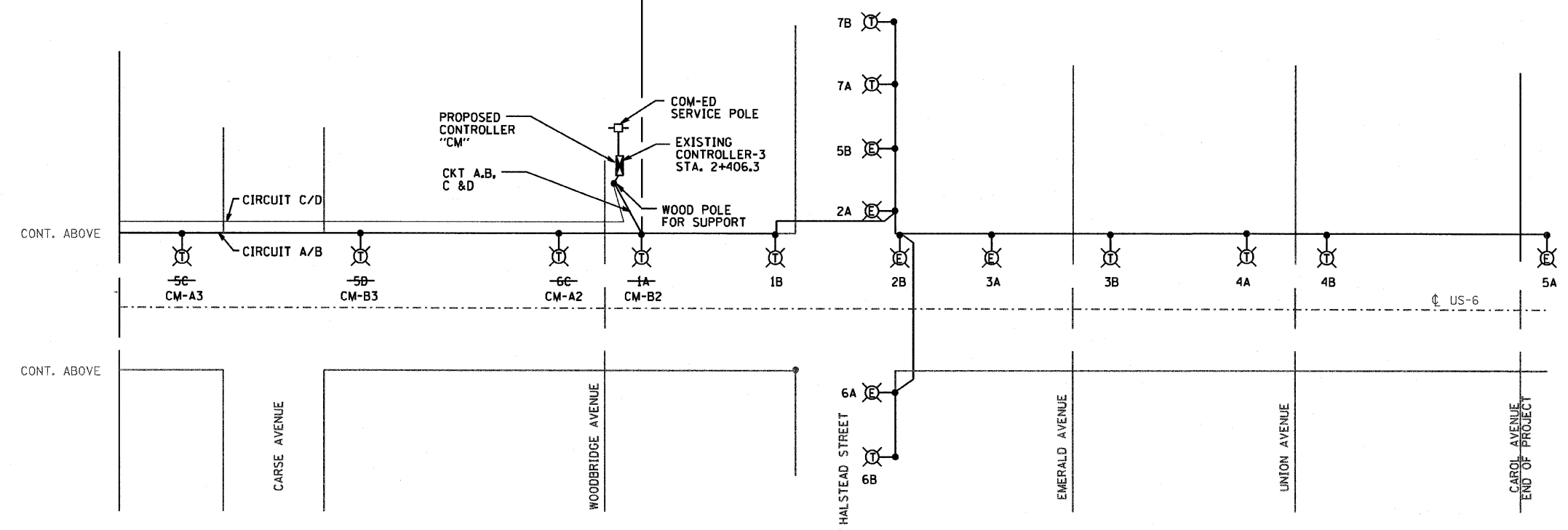

LOAD TABLE

CONTROLLER 3		
CIRCUIT NO.	LOAD	CURRENT
A	2410W	10.75A
B	3105W	9.89A
C	2500W	10.04A
D	2375W	12.43A

- LEGEND:
- LIGHT POLE, WOOD, WITH 14.5M MAST ARM
 - EXISTING LIGHT POLE
 - EXISTING LIGHTING CONTROLLER
 - ComEd SERVICE POLE
 - LIGHT POLE, WOOD, FOR SUPPORT
 - TEMPORARY WOOD POLE TO BE REMOVED

REVISIONS	
NAME	DATE

DRAWING No. E-28

ILLINOIS DEPARTMENT OF TRANSPORTATION

US RTE 6 FROM I-294 TO IL RTE 1

SINGLE LINE DIAGRAM
TEMPORARY LIGHTING
SHEET '2' OF '2'

DRAWN BY S.S./W.S.
CHECKED BY C.K./H.S.

DATE 01/28/09

F.A. RTE.	SECTION	COUNTY	TOTAL SHEETS	SHEET NO.
351	3277R	COOK	541	358
STA.		TO STA.		
FED. ROAD DIST. NO.	ILLINOIS	FED. AID PROJECT		CONTRACT NO. 60774

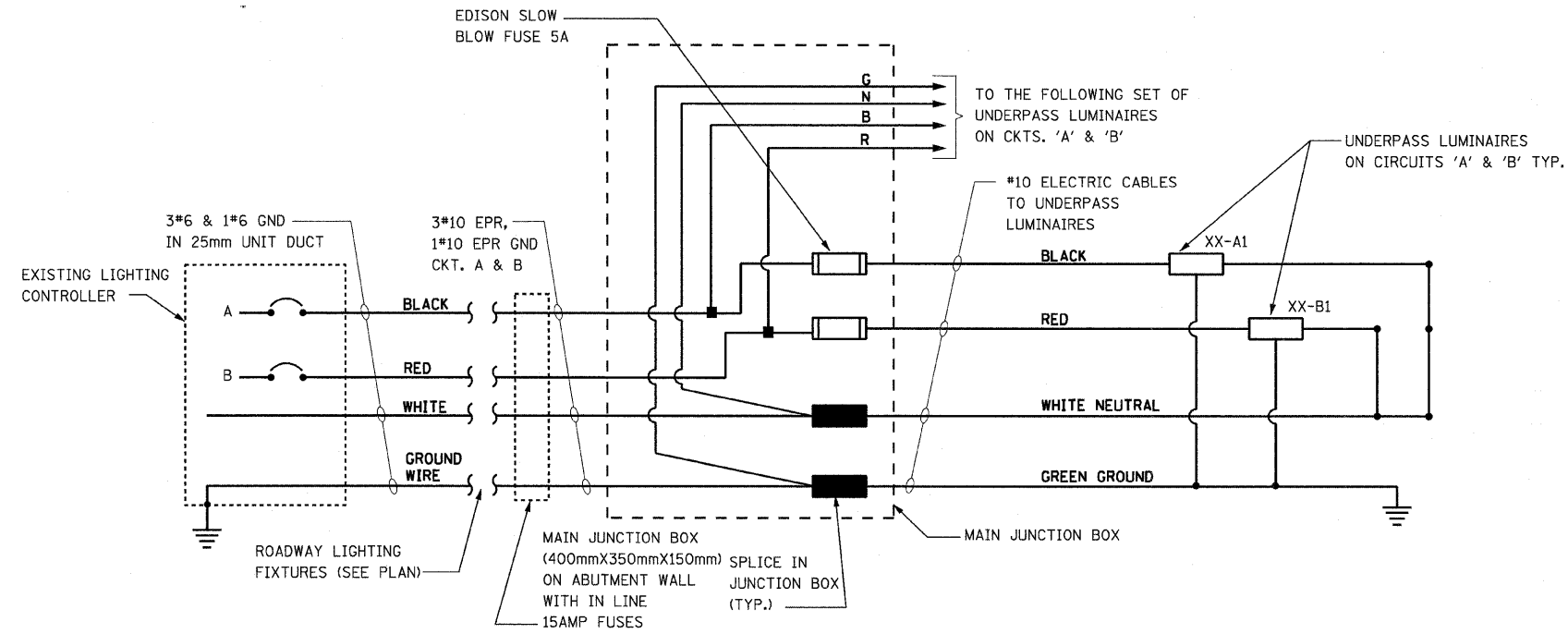

UNDERPASS LIGHTING SCHEMATIC DIAGRAM

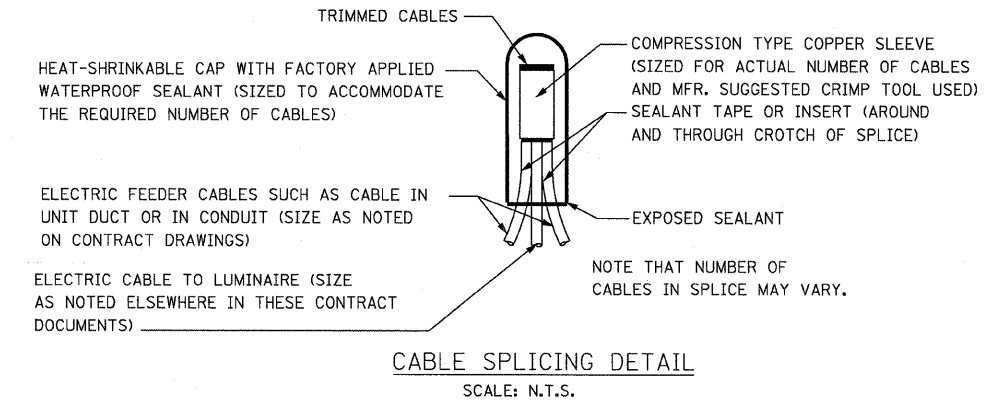

CABLE SPLICING DETAIL
SCALE: N.T.S.

DRAWING No. E-29

REVISIONS	
NAME	DATE

ILLINOIS DEPARTMENT OF TRANSPORTATION
US RTE 6 FROM I-294 TO IL RTE 1
UNDERPASS LIGHTING SCHEMATIC &
CABLE SPLICING DETAIL

SCALE AS NOTED
DATE 01/28/09
DRAWN BY S.S./W.S.
CHECKED BY C.K./H.S.

F.A.U. RTE.	SECTION	COUNTY	TOTAL SHEETS	SHEET NO.
351	3277R	COOK	541	359
STA.		TO STA.		
FED. ROAD DIST. NO.		ILLINOIS FED. AID PROJECT		

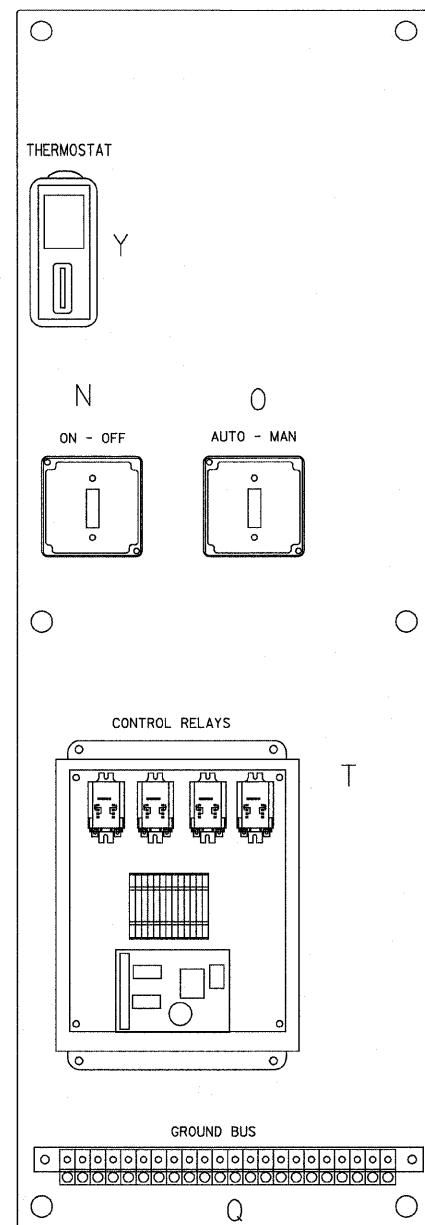

LEFT SIDE PANEL

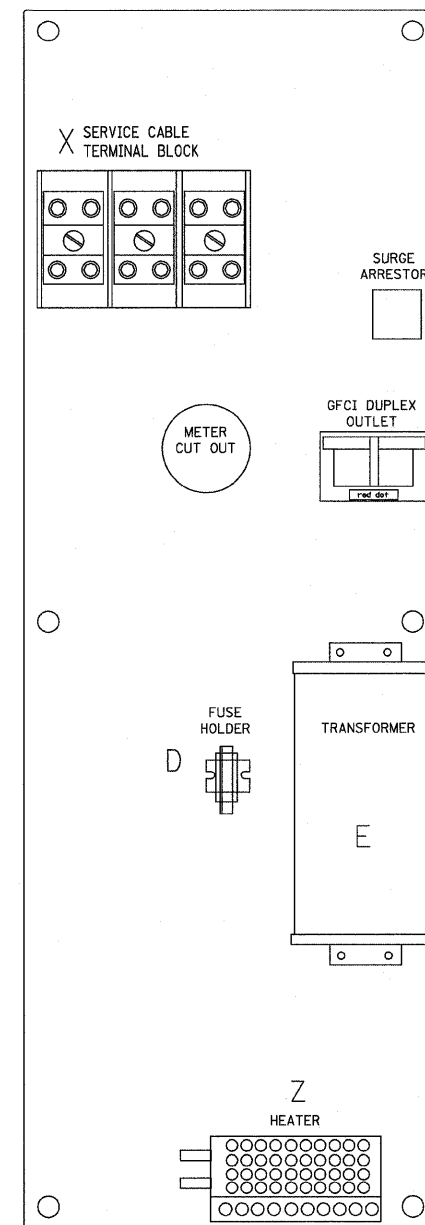
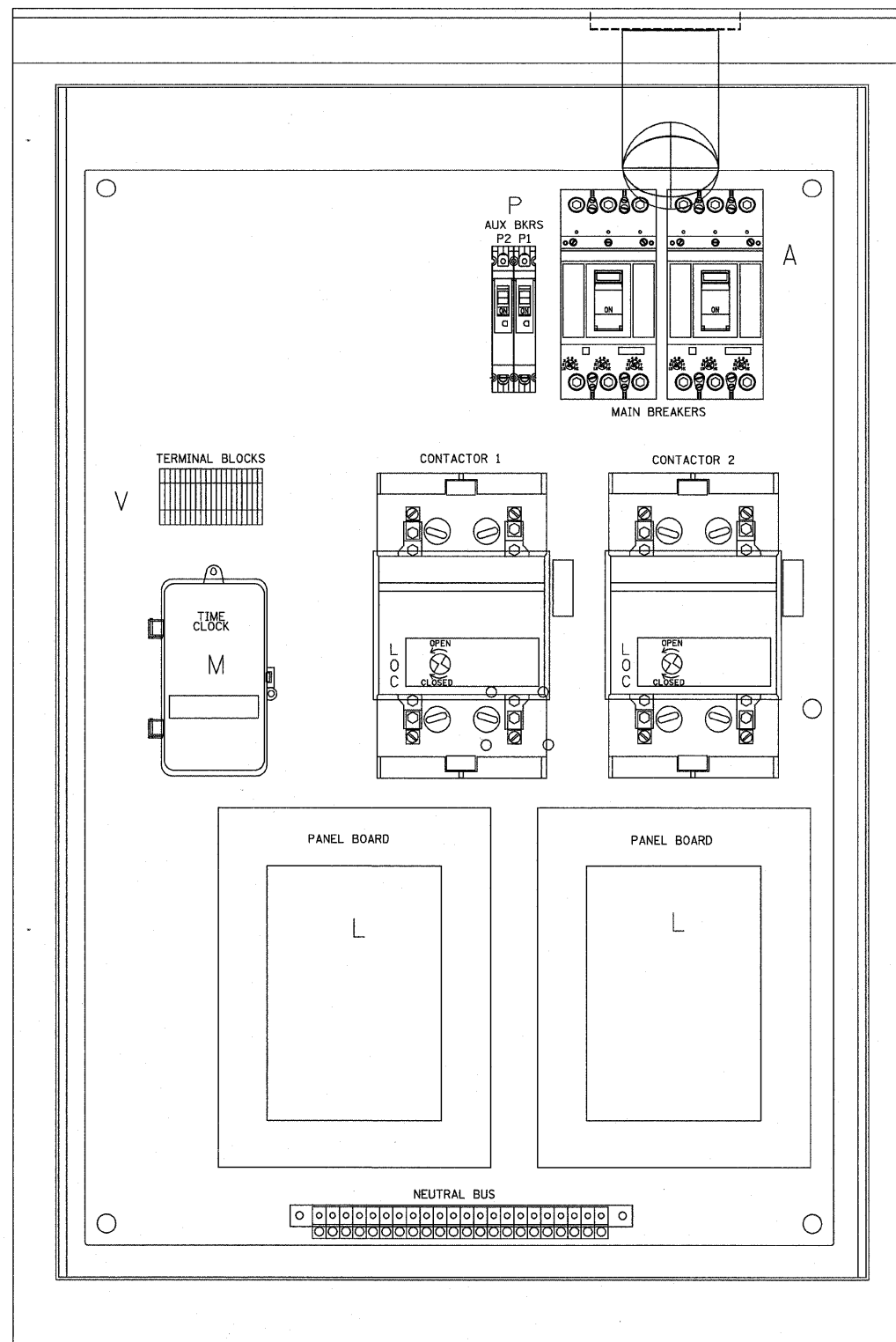

RIGHT SIDE PANEL

BILL OF MATERIALS

ITEM #	QTY	DESCRIPTION
A	2	FXD62B175 BREAKERS 2 POLE 175 AMP WITH AUX CONTACT
CLC2	2	MECHANICAL CONTRACTOR 8903PBV10X11V39 2 POLE 200 AMP 240V COIL WITH AUX CONTACTS
D	1	SECTIONAL FUSE HOLDER
E	1	1.5 KVA 277V-240/120 TRASFORMER
G	1	15 AMP GFCI
H	2	DOOR SWITCH
I	1	LIGHT FIXTURE
J	1	METER FITTING 1 PHASE 3 WIRE 200 AMP
K	1	SURGE ARRESTOR
L	2	PANEL BOARD 480/240V 1 PHASE, 250 AMP COPPER BUS
M	1	2 CHANNEL DIGITAL TIME CLOCK
N	1	MOMENTARY SWITCH ON - OF
O	1	DPDT 20 AMP AUTO-MANUAL
P1	1	BREAKER 1P 15A
P2	1	BREAKER 1P 15A
Q	2	COPPER GROUND AND NEUTRAL BUS 1 X 16 X 1/4
T	1	CONTROL RELAY ASSEMBLY 240V COILS WITH DPDT 25 AMP RELAYS (R1,R2,R3,R4), MOMENTARY CONTACT ADAPTER, QTY 12 TERMINAL BLOCKS
V	20	TERMINAL BLOCKS
X	1	620 AMP SPLICE BLOCK
Y	1	CHROMALOX WR 80, 40-80 DEG THERMOSTAT
Z	1	HEATREX 276-10 375 WATT HEATER

*

PLOT DATE = 4/18/2007
 FILE NAME = K:\data\be200.dgn
 PLOT SCALE = 40:1
 USER NAME = bboard

E-200

REVISIONS	
NAME	DATE
	12/18/02

ILLINOIS DEPARTMENT OF TRANSPORTATION

LIGHTING CONTROLLER
 DUPLEX TYPE
 SHT 1 OF 4

SCALE: VERT. NONE
 HORIZ.

DRAWN BY CADD

CHECKED BY

E-200 (BE-200)

F.A.U. RTE.	SECTION	COUNTY	TOTAL SHEETS	SHEET NO.
351	3277R	COOK	541	360
STA.	TO STA.			
FED. ROAD DIST. NO.	ILLINOIS	FED. AID PROJECT		

DEVICE SCHEDULE

ITEM	QUANT.	DESCRIPTION
(A)	2	CIRCUIT BREAKER, MOLDED CASE, THERMAL MAGNETIC, 2-POLE, 600V, A.C., 225A. FRAME, 175A. NON-INTERCHANGABLE TRIP, BOLT-ON TYPE; INTERRUPTING CAPACITY OF NOT LESS THAN 22,000 RMS SYMMETRICAL AMPERES AT 480V.
(B)	2	LIGHTING CONTACTOR (REMOTE CONTROL SWITCH) MECHANICALLY HELD, ASCO 920, MOUNTED ON SUB PANEL 200A., 2P., 600V. WITH 240V. COIL.
(C)	2	PANEL BOARD (INTERIOR ONLY) 480/240V. SINGLE PHASE WITH 200A. COPPER MAINS AND EIGHT IP-70A BOLT-ON BRANCH BREAKERS EACH RATED 277V. WITH INTERRUPTING CAPACITY OF NOT LESS THAN 14,000 RMS SYMMETRICAL AMPERES AT 277V.
(D)	1	TIME CLOCK: 240V, 60 HZ. MICROPROCESSOR BASED 2-CHANNEL CONTROLLER WITH ASTRONOMIC FUNCTIONS. RATED FOR -30 DEGREES C. TO +70 DEGREES C.
(E)	2	CIRCUIT BREAKER, MOLDED CASE, THERMAL MAGNETIC, 1-POLE, 277V., BOLT-ON TYPE, 15A WITH AN INTERRUPTING RATING OF NOT LESS THAN 14,000 RMS SYMMETRICAL AMPERES AT 277V.
(F)	1	CONTROL SWITCH, MOMENTARY CONTACT, SPDT, 20A., 240V.
(G)	1	CONTROL SWITCH, TOGGLE TYPE, SPDT, 20A., 240V. PREMIUM SPEC. GRADE
(H)	1	SOCKET FOR ELECTRIC UTILITY COMPANY METER.
(I)	1	STEP DOWN TRANSFORMER 240V.-120V., 1KVA.
(J)	2	FUSE HOLDER 15A., 250V., 5A. FUSE
(K)	1	20A. SPST MICRO SWITCH (MOUNT WITH ACTUATOR TO SWITCH WHEN DOOR OPENED)
(L)	1	60 WATT LIGHT FIXTURE, VAPOR TIGHT, WITH GLOBE AND GUARD AND MOUNTING BOX.
(M)	1	GFI RECEPTACLE, 120V., 20A., PREMIUM SPEC. GRADE. NEMA REFERENCE 5-15R IN WEATHER-PROOF BOX WITH FLAP-TYPE COVER.

NOTES:

- ALL CONTROL CABINET ITEMS SHALL HAVE SUITABLE IDENTIFICATION. OPEN CIRCUIT BREAKERS, CONTACTORS AND OTHER OPEN DEVICES SHALL HAVE PERMANENT SELF STICKING TAGS. DEVICES IN ENCLOSURES SHALL HAVE ENGRAVED 2-COLOR LAMINATED PLASTIC NAMEPLATES ATTACHED TO ENCLOSURES WITH SCREWS. NAMEPLATES SHALL BE ENGRAVED TO CORRESPOND TO DESIGNATIONS ON THE DRAWINGS. INTERNAL CABINET WIRING SHALL BE IDENTIFIED AS INDICATED OR AS DIRECTED BY THE ENGINEER BY MEANS OF SELF-STICKING TAGS APPLIED AT EACH CONNECTED END. IDENTIFICATION SHALL BE MADE BY THE CABINET MANUFACTURER.
- ALL WIRING WITHIN THE CABINET SHALL BE COLOR CODED AS INDICATED.
R = RED BL = BLUE W = WHITE
B = BLACK Y = YELLOW G = GREEN
- PROVIDE SEALING GROMMETS FOR ALL OPEN WIRING EXTENDED FROM DEVICES IN BOXES OR CABINETS WITHIN THE CONTROL CABINET.
- ALL 120 VOLT SYSTEM AND ALL CONTROL WIRING SHALL BE #12AWG STRANDED UNLESS OTHERWISE INDICATED.
- ALL WIRING SHALL BE NEATLY DRESSED AND SUPPORTED.
- THE CONTROLLER SHALL BE CONSTRUCTED TO U.L. STD. 508 AND BEAR THE U.L. LABEL "ENCLOSED INDUSTRIAL CONTROL PANEL"
- SEE CABINET AND FOUNDATION DETAIL SHEET FOR SCHEMATIC DIAGRAM AND DEVICE LAYOUT.
- CONTROL RELAYS CAN BE ELIMINATED IF THE CONTROL TIME CLOCK OUTPUT CONTACTS ARE RATED FOR CONTACTOR INRUSH CURRENT.

E-200

ILLINOIS DEPARTMENT OF TRANSPORTATION
CONTROL CABINET, DUPLEX TYPE
WIRING DETAIL
SHEET 2 OF 4

REVISIONS	
NAME	DATE
G. BRATKIV	06-30-86
M. BURNS	07-25-91
S. MANLEY	10-11-93

SCALE: VERT.
HORIZ.
DATE: 2/15/2006

DRAWN BY
CHECKED BY
E-200 (BE-200)

REVISION DATE: 12/18/02

SEE SHEET 2 OF 2
FOR PANEL LAYOUT

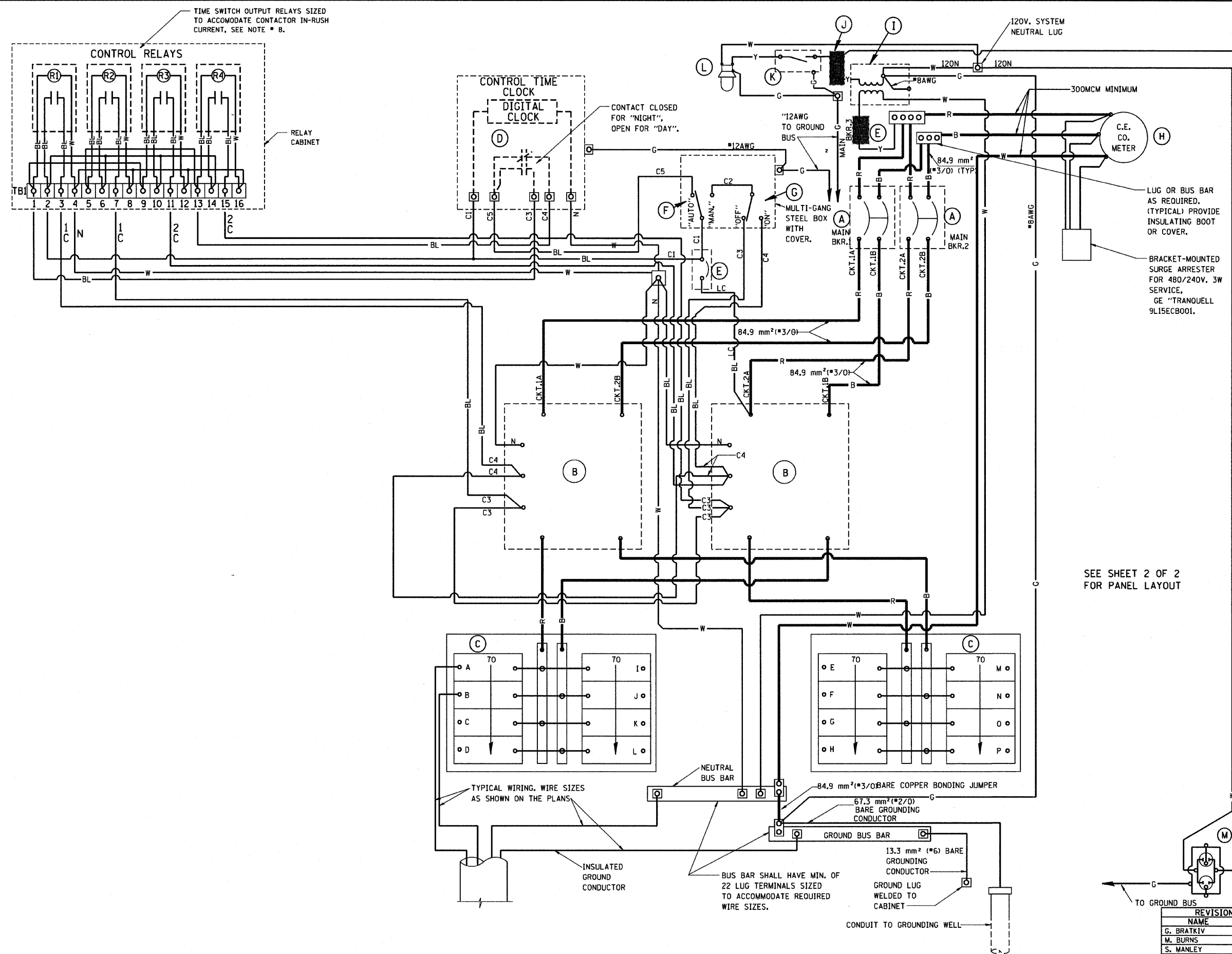

TIME SWITCH OUTPUT RELAYS SIZED TO ACCOMMODATE CONTACTOR IN-RUSH CURRENT, SEE NOTE # 8.

CONTROL RELAYS

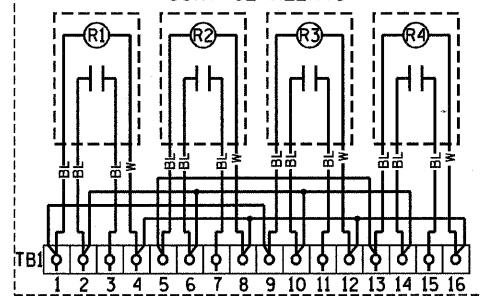

CONTROL TIME CLOCK

DIGITAL CLOCK

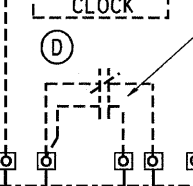

CONTACT CLOSED FOR "NIGHT", OPEN FOR "DAY".

"12AWG TO GROUND BUS"

"MULTI-GANG STEEL BOX WITH COVER"

"AUTO" "MAN" "OFF" "ON"

"MAIN BKR. 1" "MAIN BKR. 2" "MAIN BKR. 3"

"CKT. 1A" "CKT. 1B" "CKT. 2A" "CKT. 2B"

"84.9 mm² (#3/0)"

"84.9 mm² (#3/0)"

"84.9 mm² (#3/0)"

"84.9 mm² (#3/0)"

"84.9 mm² (#3/0)"

"84.9 mm² (#3/0)"

"84.9 mm² (#3/0)"

"84.9 mm² (#3/0)"

"84.9 mm² (#3/0)"

"84.9 mm² (#3/0)"

"84.9 mm² (#3/0)"

"84.9 mm² (#3/0)"

"84.9 mm² (#3/0)"

"84.9 mm² (#3/0)"

"84.9 mm² (#3/0)"

"84.9 mm² (#3/0)"

"84.9 mm² (#3/0)"

"84.9 mm² (#3/0)"

"84.9 mm² (#3/0)"

"84.9 mm² (#3/0)"

"84.9 mm² (#3/0)"

"84.9 mm² (#3/0)"

"84.9 mm² (#3/0)"

PLOT DATE: 2/15/2006
FILE NAME: \\adiv\csc\user200\dgn
SCALE: 4:1
USER: NAME: gplundmck

TYPICAL WIRING. WIRE SIZES AS SHOWN ON THE PLANS

INSULATED GROUND CONDUCTOR

BUS BAR SHALL HAVE MIN. OF 22 LUG TERMINALS SIZED TO ACCOMMODATE REQUIRED WIRE SIZES.

84.9 mm² (#3/0) BARE COPPER BONDING JUMPER

67.3 mm² (#2/0) BARE GROUNDING CONDUCTOR

GROUND BUS BAR

13.3 mm² (#6) BARE GROUNDING CONDUCTOR

GROUND LUG WELDED TO CABINET

CONDUIT TO GROUNDING WELL

F.A.A. RTE.	SECTION	COUNTY	TOTAL SHEETS	SHEET NO.
351	3277R	COOK	541	361
STA.		TO STA.		
FED. ROAD DIST. NO.		ILLINOIS FED. AID PROJECT		

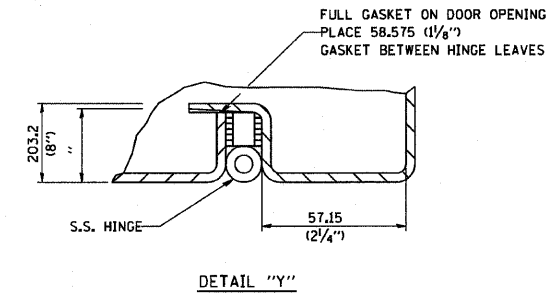

DETAIL "Y"

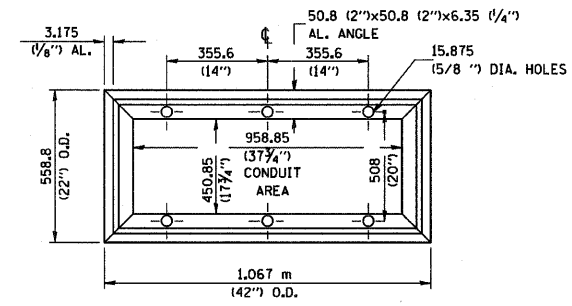

BASE MTG. DETAIL

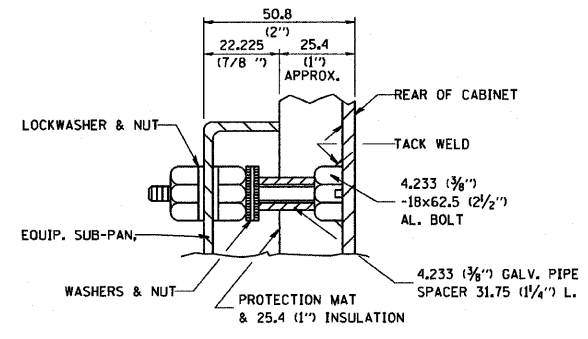

DETAIL "X"

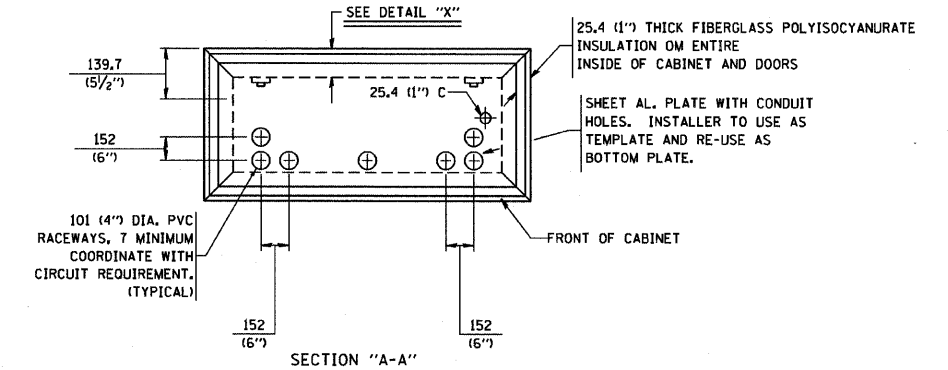

SECTION "A-A"

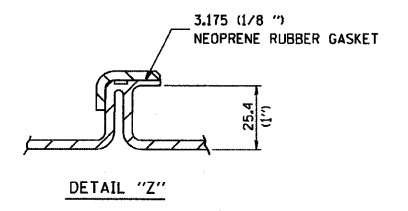

DETAIL "Z"

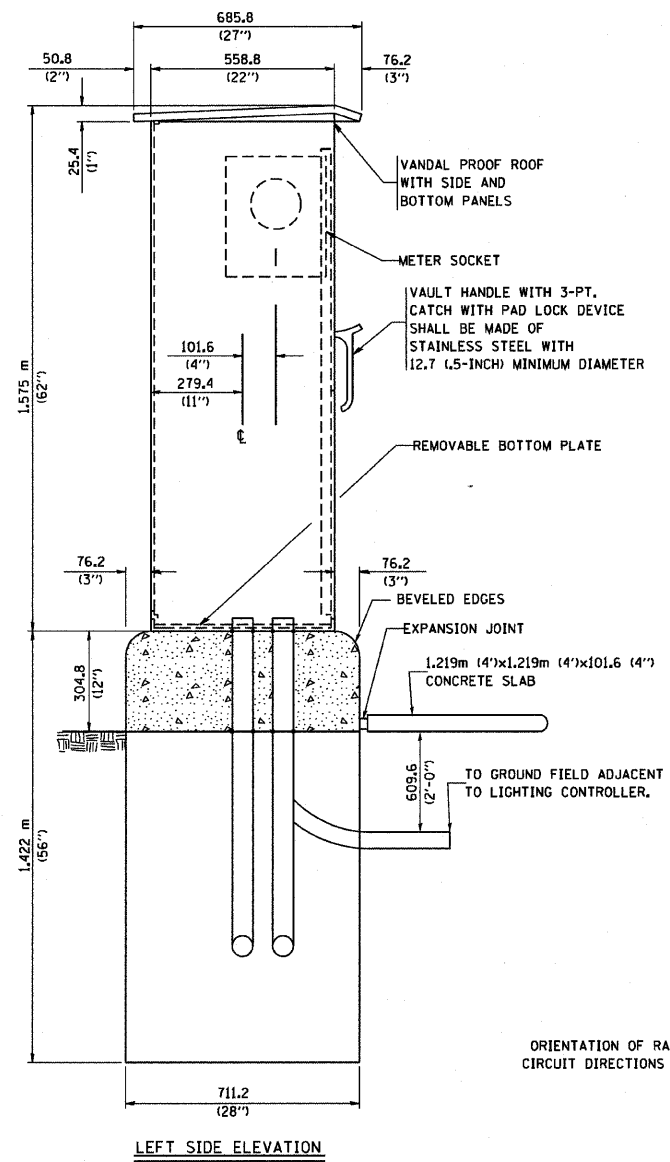

LEFT SIDE ELEVATION

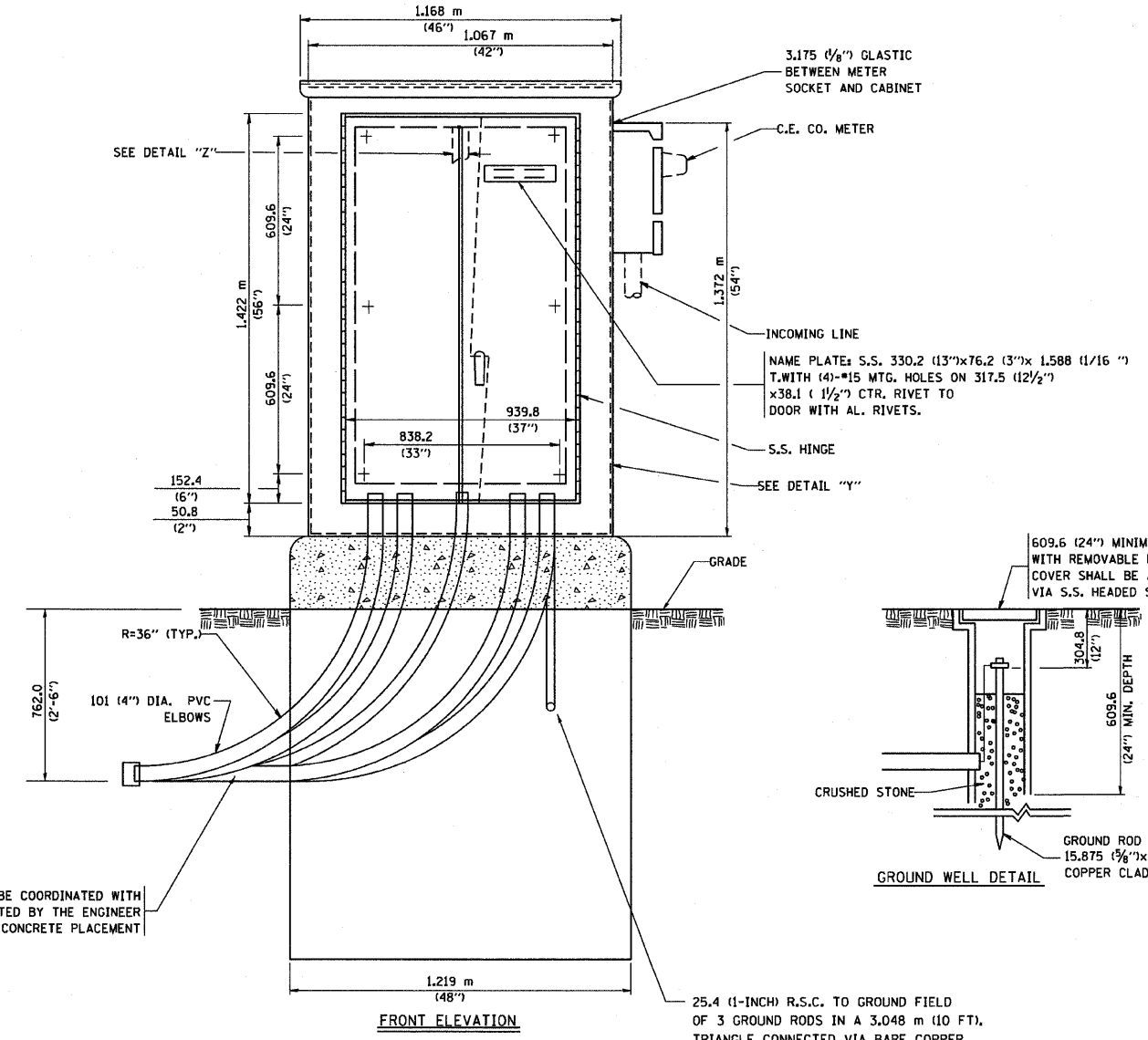

FRONT ELEVATION

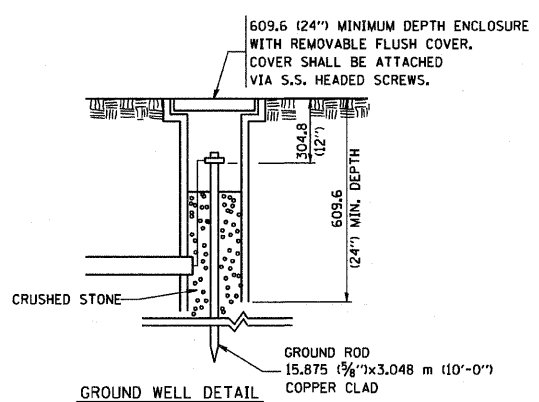

GROUND WELL DETAIL

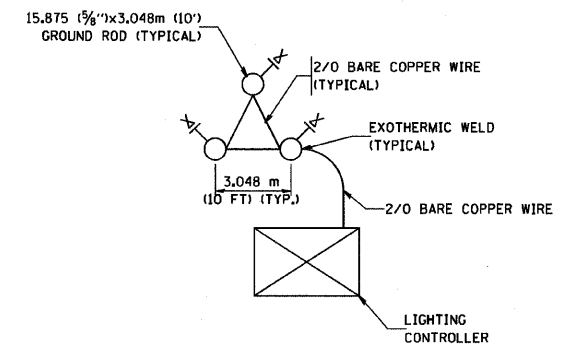

GROUND FIELD DETAIL (N.T.S.)

THE CONTRACTOR SHALL VERIFY EXACT LOCATION WITH THE ENGINEER

ORIENTATION OF RACEWAYS SHALL BE COORDINATED WITH CIRCUIT DIRECTIONS AND BE INSPECTED BY THE ENGINEER PRIOR TO CONCRETE PLACEMENT

25.4 (1-INCH) R.S.C. TO GROUND FIELD OF 3 GROUND RODS IN A 3.048 m (10 FT.) TRIANGLE CONNECTED VIA BARE COPPER WIRE. VERIFY EXACT LOCATION OF GROUND FIELD WITH THE ENGINEER. NO GROUND WELL SHALL BE PLACED IN CONCRETE PAD IN FRONT OF CONTROLLER.

REVISIONS	
NAME	DATE

ILLINOIS DEPARTMENT OF TRANSPORTATION
 LIGHTING CONTROLLER,
 DUPLEX TYPE
 SHT 3 OF 4

SCALE: VERT. HORIZ.
 DATE: 4/26/2006

DRAWN BY C.A.D.
 CHECKED BY
 E-200 (BE-200)
 REVISION DATE: 04/26/06

PLOT DATE = 4/26/2006
 FILE NAME = c:\projects\states\be200.dgn
 USER = jg
 USER NAME = jg

F.A.U. RTE.	SECTION	COUNTY	TOTAL SHEETS	SHEET NO.
351	3277R	COOK	541	362
STA.		TO STA.		
FED. ROAD DIST. NO.		ILLINOIS FED. AID PROJECT		

NOTES

1. CABINET SHALL BE FABRICATED FROM 3.175 (0.125-INCH) SHEET ALUMINUM
* 3003H14, FORMED AND ARC WELDED ASSEMBLY.
2. ALL SCREWS AND HARDWARE SHALL BE PLATED, GALVANIZED, OR MADE OF BRASS, ALUMINUM OR STAINLESS STEEL.
3. NAME PLATE SHALL HAVE ENGRAVED 19.05 (0.75-INCH) HIGH LETTERS FILLED IN BLACK: "STATE OF ILLINOIS LIGHTING CONTROLS" UNLESS OTHERWISE SPECIFIED.
4. ONE INCH THICK POLYISOCYANURATE INSULATION SHALL BE INSTALL AND PERMANENTLY CEMENTED ON ALL SIDES OF THE CABINET AND DOORS.
5. CABINET SHALL BE PRIMED AND PAINTED AS SPECIFIED.
6. ELECTRIC UTILITY METER BOX SHALL BE MOUNTED ON THE SIDE OF CONTROL CABINET AS SHOWN ON THE PANEL LAYOUT DIAGRAM.
7. THE COMPLETED CONTROLLER SHALL BE U.L. LISTED AS AN INDUSTRIAL CONTROL PANEL UNDER UL508.
8. METAL MOUNTING PANEL SHALL BE *10 GAUGE GALVANIZED SHEET STEEL FLANGED BACK 0.75-INCHES I.D. ON 4 SIDES.
9. CIRCUIT BREAKERS AND CONTACTORS AND OTHER COMPONENTS SHALL BE MOUNTED ON 3.175 (0.125-INCH) THICK GLASTIC INSULATION BACK PANEL.
10. ALL DEVICES SHALL BE FRONT REMOVABLE.
11. TIME CLOCK CHANNEL 1 N.O. CONTACT IS CLOSED NIGHT AND OPEN DAY
12. SET "ON TIME" TO 30 MINUTES AFTER ASTRONOMICAL SUNSET.
13. BUS BAR SHALL HAVE 22 LUG TERMINALS SIZED TO ACCOMMODATE REQUIRED WIRE SIZES. NEUTRAL BUS SHALL BE PAINTED WHITE. GROUND BUS SHALL BE PAINTED GREEN.
14. ALL LUGS SHALL BE OF COPPER SCREWS AND CONNECTORS, SPRING HELD.
15. ALL WIRING TERMINATIONS SHALL BE RATED NOT LESS THAN 75 DEGREE CENTIGRADE
16. ALL CONTROL WIRING SHALL BE 600V MACHINE TOOL WIRE TYPE MTW.
17. ALL POWER WIRING SHALL BE 600V TYPE RHH/RHW.
18. ALL WIRING WITHIN THE CABINET SHALL BE COLOR CODED AS INDICATED:
 R - RED Y - YELLOW
 B - BLACK W - WHITE
 BL- BLUE G - GREEN
19. ALL DIMENSIONS ARE IN MILIMETERS (INCHES) UNLESS OTHERWISE INDICATED
20. SCHEMATIC SHOWN WITH BREAKER OPEN, CONTACTOR OPEN, CABINET DOOR CLOSED, CLOCK NOT ACTIVE
21. A LAMINATED COPY OF THE CIRCUIT SCHEMATIC AND SCADA I/O DIAGRAM SHALL BE ATTACHED TO THE INSIDE OF THE CONTROLLER

E-200

REVISIONS	
NAME	DATE

ILLINOIS DEPARTMENT OF TRANSPORTATION

LIGHTING CONTROLLER
 DUPLEX TYPE
 SHT 4 OF 4

SCALE: VERT.
 HORIZ.
 DATE: 2/15/2006

DRAWN BY CADD
 CHECKED BY

E-200 (BE-200)
 REVISION DATE: 12/18/02

F.A.U. RTE.	SECTION	COUNTY	TOTAL SHEETS	SHEET NO.
351	3277R	COOK	541	363
STA.		TO STA.		
FED. ROAD DIST. NO.		ILLINOIS FED. AID PROJECT		

APPLICATION

THIS DETAIL APPLIES FOR LOW VOLTAGE ELECTRIC SERVICE (660 V OR LESS) FROM AN OVERHEAD UTILITY SUPPLY TO SEPERATLY-MOUNTED SERVICE EQUIPMENT.

NOTES

- SERVICE VOLTAGE SHALL BE AS INDICATED ELSEWHERE IN THE DRAWINGS.
- UNLESS OTHERWISE INDICATED, ITEMS AND WORK SHALL BE INCLUDED AND PAID AS PART OF THE ELECTRIC UTILITY SERVICE INSTALLATION PAY ITEM.
- CONDUIT AND CONNECTOR DIAMETER SHALL MATCH THE DIAMETER OF THE SERVICE CONDUCTOR RACEWAY AS INDICATED ON THE PLANS.
- PVC COATED RACEWAYS AND ACCESSORIES SHALL BE CAREFULLY INSTALLED WITH MFR RECOMMENDED TOOLS AND PROCEDURES TO AVOID DAMAGE. ANY DAMAGE SHALL BE REPAIRED WITH COMPATIBLE PVC TOUCH-UP MATERIAL TO THE SATISFACTION OF THE ENGINEER OR THE DAMAGED MATERIAL SHALL BE REPLACED AT NO ADDITIONAL COST.
- THE CONTRACTOR SHALL OBTAIN INSPECTION AND APPROVAL BY THE ENGINEER OF SERVICE RISER GROUND ELECTRODE, RISER ELBOW, NIPPLE AND CONNECTION TO SERVICE CONDUCTOR RACEWAY EXTENSION BEFORE BACKFILL AND SHALL ALSO OBTAIN INSPECTION OF SERVICE RISER AND SEALING BUSHING BEFORE UTILITY "U" GUARD INSTALLATION AND SERVICE CONNECTION.
- THE HORIZONTAL ELECTRIC SERVICE CONDUCTOR RACEWAY SHALL BE AS INDICATED AND SHALL BE MEASURED SEPARATELY FOR PAYMENT. WHEN THE RACEWAY IS PVC-COATED RIGID GALVANIZED STEEL, THE COUPLING SHALL BE THE SAME. WHEN THE RACEWAY IS PVC CONDUIT (IN CONCRETE), THE COUPLING SHALL BE A METALIC TO NON METALIC ADAPTER. WHEN THE RACEWAY IS ENCASED IN CONCRETE, THE CONCRETE SHALL EXTEND TO COVER THE COUPLING.
- PLANS AND DETAILS INDICATE THE GENERAL NATURE AND REQUIREMENTS. THEY DO NOT SHOW EVERY ACCESSORY AND ATTACHMENT, AND THEY DO NOT RELIEVE THE CONTRACTOR OF THE REQUIREMENTS OF THE SPECIFICATIONS AND SPECIAL PROVISIONS TO ASCERTAIN UTILITY REQUIREMENTS AND TO COORDINATE ACCORDINGLY, FURNISHING ALL ITEMS AND WORK NOT PROVIDED BY THE UTILITY, BUT NECESSARY FOR A COMPLETE SERVICE INSTALLATION IS REQUIRED AND SHALL BE INCLUDED IN THE ELECTRIC UTILITY SERVICE INSTALLATION PAY ITEM.

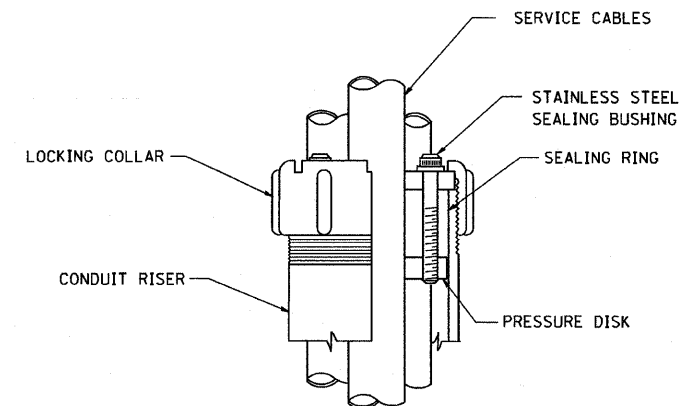

SEALING BUSHING DETAIL

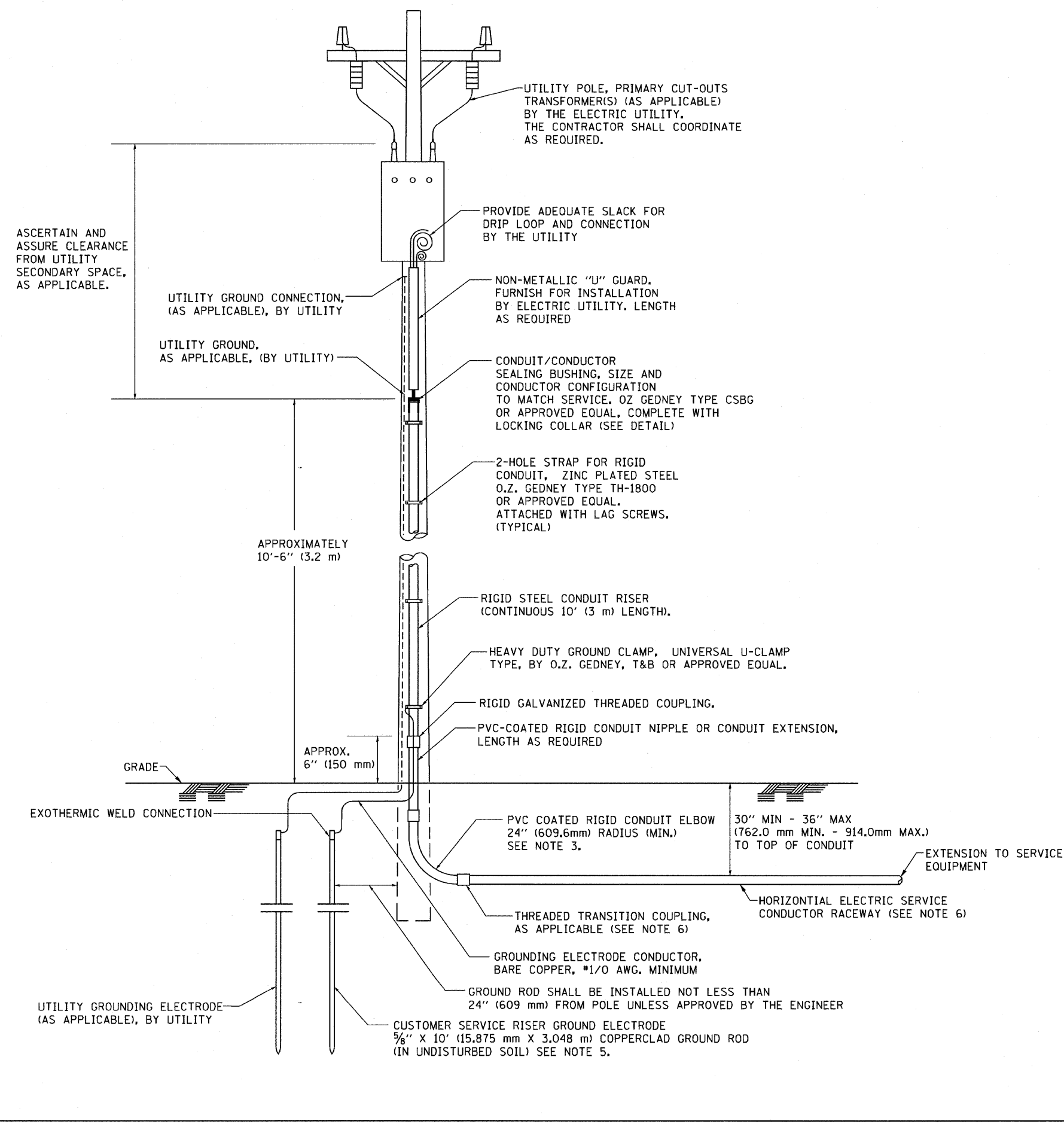

PLOT DATE = 1/9/2007
 FILE NAME = c:\projects\adnet\adnet28.dgn
 USER NAME = 08/08/07 / JN.
 USER NAME =

BE-220

REVISIONS	
NAME	DATE

ILLINOIS DEPARTMENT OF TRANSPORTATION

**ELECTRIC SERVICE INSTALLATION
AERIAL, REMOTE DISCONNECT
BE - 220**

SCALE: NONE
DATE: 1/9/2007

DRAWN BY
CHECKED BY MEA

F.A.U. RT.	SECTION	COUNTY	TOTAL SHEETS	SHEET NO.
351	3277R	COOK	541	364
STA.		TO STA.		
FED. ROAD DIST. NO.		ILLINOIS FED. AID PROJECT		

LIGHT POLE FOUNDATION DEPTH TABLE
40 FT. (12.192 m) TO 47.5 FT. (14.478 m) MOUNTING HEIGHT

SOIL CONDITIONS	DESIGN DEPTH "D" OF FOUNDATION	
	SINGLE ARM POLE	TWIN ARM POLE
SOFT CLAY O _u = 0.375 TON/SO. FT.	13'-0" (3.96 m)	15'-0" (4.57 m)
MEDIUM CLAY O _u = 0.75 TON/SO. FT.	9'-6" (2.93 m)	10'-9" (3.23 m)
STIFF CLAY O _u = 1.50 TON/SO. FT.	7'-0" (2.13 m)	8'-0" (2.44 m)
LOOSE SAND φ = 34°	9'-0" (2.74 m)	10'-0" (3.05 m)
MEDIUM SAND φ = 37.5°	8'-3" (2.52 m)	9'-0" (2.74 m)
DENSE SAND φ = 40°	7'-9" (2.36 m)	9'-0" (2.74 m)

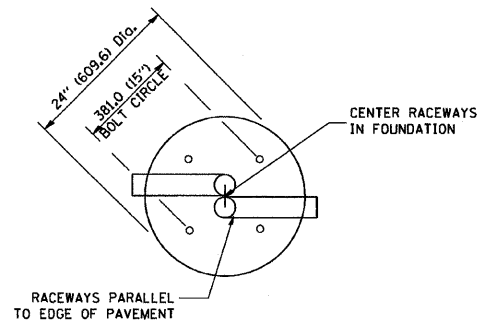

TOP VIEW

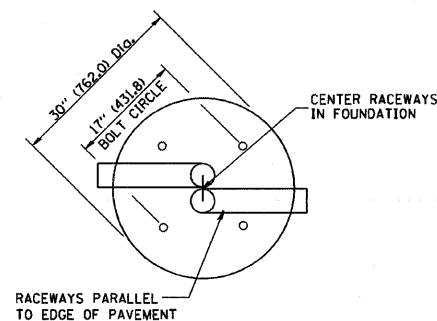

TOP VIEW

NOTES

- ALL DIMENSIONS ARE IN INCHES (MILLIMETERS) UNLESS OTHERWISE SHOWN.
- THE ANCHOR RODS AND RACEWAYS SHALL BE PROPERLY SECURED IN PLACE BEFORE THE CONCRETE IS PLACED.
- THE FOUNDATION SHALL NOT PROTRUDE MORE THAN 100MM (4 IN.) ABOVE THE FINISHED GRADE WITHIN A 60 IN. (1.5 m) CHORD ACROSS THE FOUNDATION, WITH ANCHOR RODS INCLUDED, IN ACCORDANCE WITH AASHTO GUIDELINES. IF THE FOUNDATION HEIGHT, INCLUDING ANCHOR RODS, EXTENDS BEYOND THESE SPECIFIED LIMITS, THE FOUNDATION SHALL BE REPLACED AT THE CONTRACTOR'S EXPENSE. SEE FOUNDATION EXTENSION DETAIL.
- THE HOLE FOR THE FOUNDATION SHALL BE MADE BY DRILLING WITH AN AUGER, OF THE SAME DIAMETER AS THE FOUNDATION. IF SOIL CONDITIONS REQUIRE THE USE OF A LINER TO FORM THE HOLE, THE LINER SHALL BE WITHDRAWN AS THE CONCRETE IS DEPOSITED.
- THE TOP OF THE FOUNDATION SHALL BE CONSTRUCTED LEVEL. A LINER OR FORM SHALL BE USED TO PRODUCE A UNIFORM SMOOTH SIDE TO THE TOP OF THE FOUNDATION. FOUNDATION TOP SHALL BE CHAMFERED 3/4-IN. (20 mm).
- THE CONCRETE SHALL BE CLASS SI. CONCRETE SHALL CURE ACCORDING TO ARTICLE 1020.13 BEFORE LIGHT POLES ARE INSTALLED.
- THE ANCHOR ROD SHALL BE A HOOK ROD TYPE. COLD BENDING OF THE ANCHOR ROD WILL NOT BE ALLOWED. THE RADIUS OF THE HOOK BEND SHALL NOT BE LESS THAN 4 TIMES THE NOMINAL DIAMETER OF THE ANCHOR ROD. A TACK WELDED ANCHOR ROD MAY BE SUBSTITUTED WITH THE APPROVAL OF THE ENGINEER.
- THE ANCHOR RODS SHALL BE ACCORDING TO ASTM F1554 GRADE 725 (GRADE 105). NUTS SHALL BE HEXAGON NUTS ACCORDING TO ASTM A 194 2H OR ASTM A 563 DH, AND WASHERS SHALL BE ACCORDING TO ASTM F 436.
- ANCHOR RODS, NUTS AND WASHERS SHALL BE COMPLETELY GALVANIZED BY EITHER THE HOT-DIPPED PROCESS CONFORMING WITH AASHTO M 232, THE MECHANICAL PLATING METHOD CONFORMING TO AASHTO M 298, CLASS 50 WITH A MAXIMUM COATING THICKNESS OF 150 UMG MILS) OR THE ELECTROLYTIC PROCESS ACCORDING TO ASTM F 1136.
- THE ANCHOR RODS SHALL BE THREADED A MINIMUM OF 6 INCHES (150 mm) WITH A MINIMUM OF 3 INCHES (75 mm) OF THREADED ANCHOR ROD EMBEDDED IN THE FOUNDATION.
- ANCHOR RODS SHALL PROJECT 2 3/4" (69.9 mm) ABOVE THE TOP OF THE FOUNDATION. IF BREAKAWAY COUPLINGS ARE SPECIFIED, THE CONTRACTOR SHALL CAREFULLY COORDINATE THE ANCHOR ROD PROJECTION WITH THE INSTALLATION REQUIREMENTS OF THE BREAKAWAY COUPLINGS.
- THE CONTRACTOR SHALL USE A #3 SPIRAL AT 6" (152.4 mm) PITCH OR MAY SUBSTITUTE #3 TIES AT 12" (304.8 mm) O.C. WITH THE APPROVAL OF THE ENGINEER.
- THE CABLE TRENCHES AND FOUNDATION SHALL BE BACK FILLED AND COMPACTED AS SPECIFIED BEFORE THE LIGHT POLE IS ERECTED.
- THE RACEWAYS SHALL PROJECT 1" (25.4 mm) ABOVE THE TOP OF THE FOUNDATION.

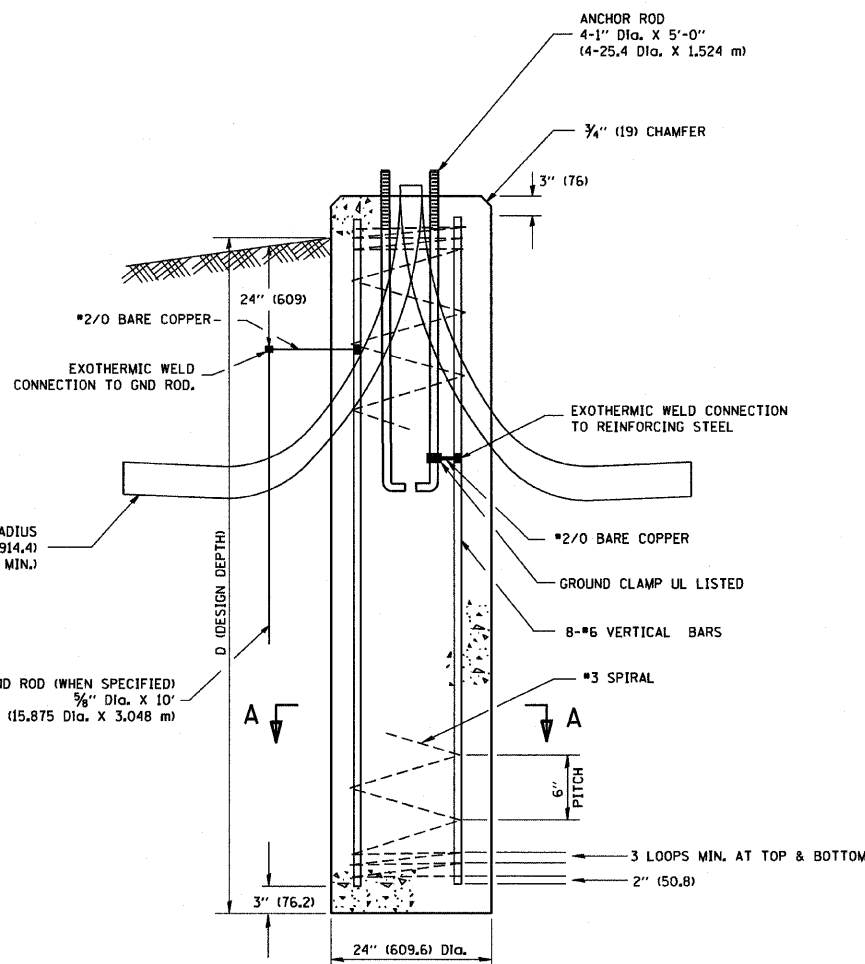

FOUNDATION DETAIL

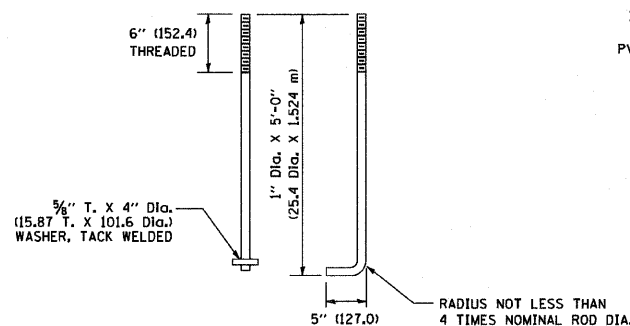

ANCHOR ROD DETAIL

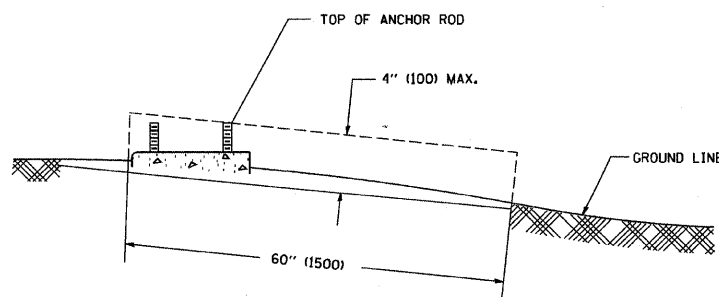

FOUNDATION EXTENSION DETAIL

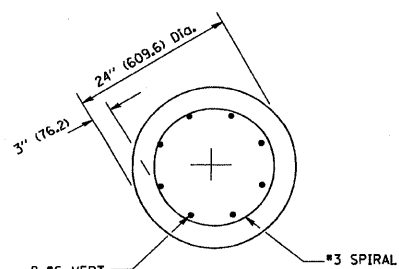

SECTION A-A

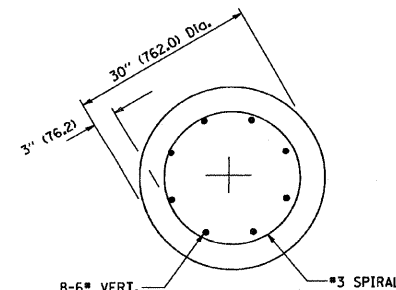

SECTION A-A

REVISIONS	
NAME	DATE
	04/22/02

ILLINOIS DEPARTMENT OF TRANSPORTATION
LIGHT POLE FOUNDATION
40' (12.192 m) TO 47 1/2' (14.478 m) M.H.
15" (381) BOLT CIRCLE

SCALE: NONE

DRAWN BY
CHECKED BY
BE301

F.A.U. RTE.	SECTION	COUNTY	TOTAL SHEETS	SHEET NO.
351	3277R	COOK	541	365
STA.		TO STA.		
FED. ROAD DIST. NO.		ILLINOIS FED. AID PROJECT		

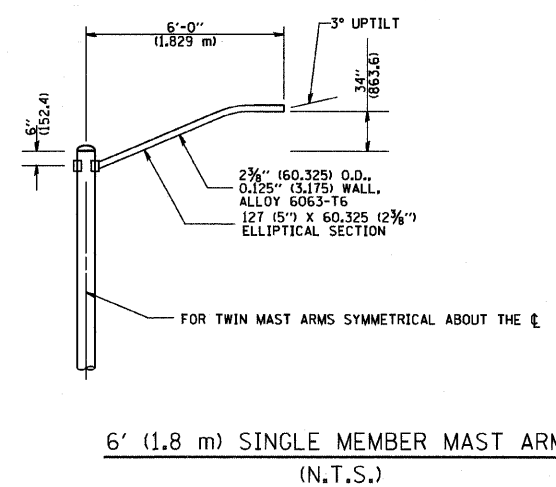
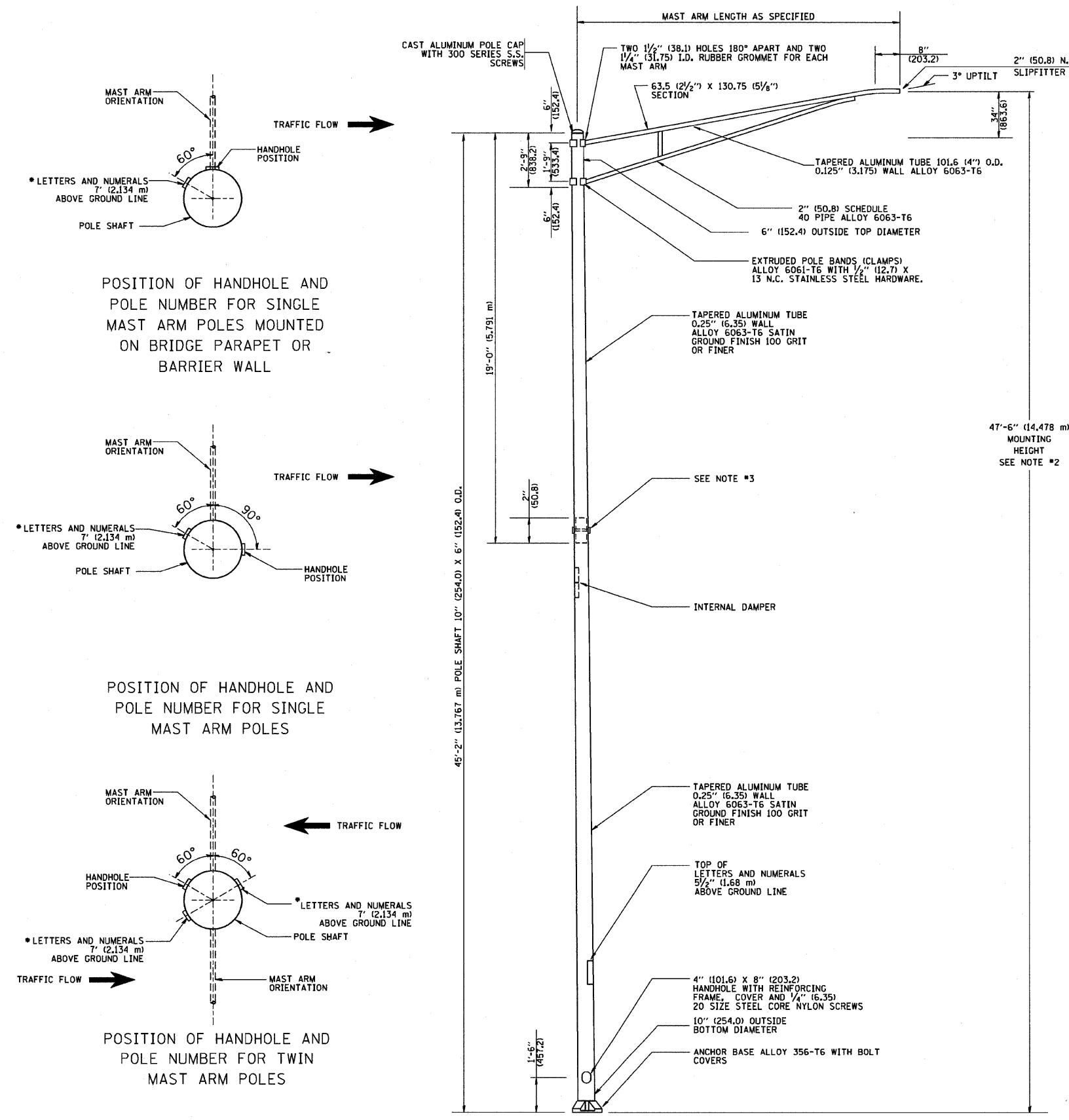

- NOTES:
1. ALL DIMENSIONS ARE IN INCHES (MILLIMETERS) UNLESS OTHERWISE SHOWN.
 2. MOUNTING HEIGHT IS DEFINED AS THE DISTANCE FROM THE CENTERLINE OF THE TENON TO THE BOTTOM OF THE ANCHOR BASE.
 3. TWO PIECE SHAFT WILL BE MATCHED MARKED AND INTERCHANGEABLE BETWEEN DIFFERENT UNITS. FIELD DRILLING OF THE HOLES WILL NOT BE ALLOWED.
 4. THE LIGHT POLE WILL MEET AASHTO DESIGN CRITERIA AS SPECIFIED.
 5. THE INSTALLING CONTRACTOR WILL PROVIDE A UL LISTED GROUNDING CONNECTOR, BURNDY K2C23, T&B SP4DL OR APPROVED EQUAL.
 6. LIGHT POLES WILL NOT BE INSTALLED WITHOUT MAST ARMS AND LUMINAIRES.
 7. LIGHT POLES WILL BE SET PLUMB ON THE FOUNDATION WITHOUT THE USE OF LEVELING NUTS, WASHERS OR SHIMS.
 8. LIGHTING UNIT IDENTIFICATION NUMBERS SHALL BE INSTALLED BEFORE THE LIGHTING UNIT IS ENERGIZED.

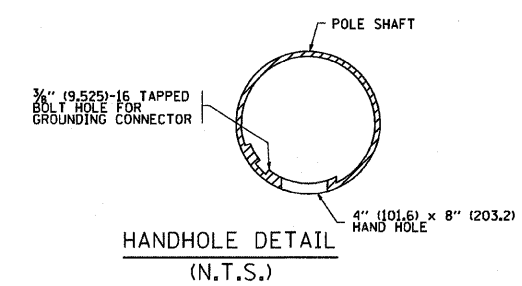
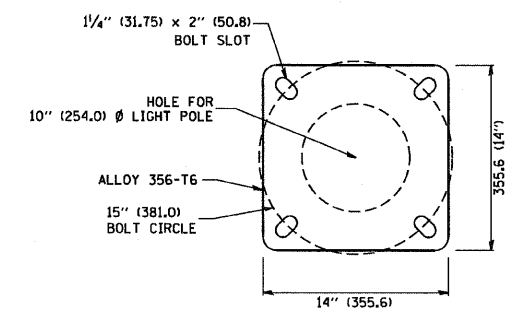
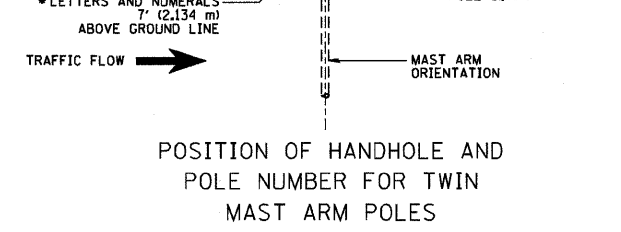
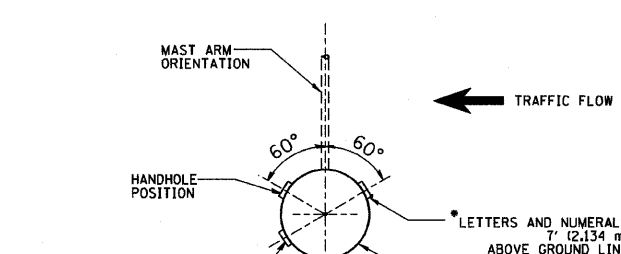
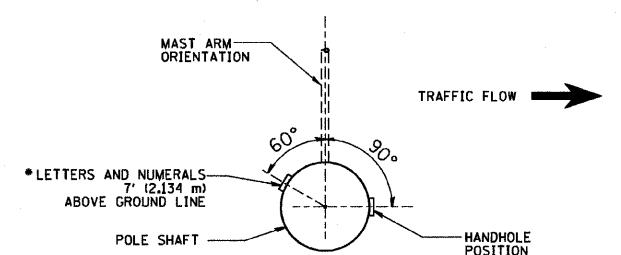
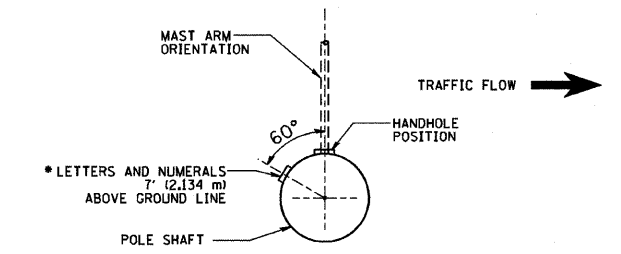

REVISIONS	
NAME	DATE
R. TOMSONS	9-6-00
R. TOMSONS	8-12-03

ILLINOIS DEPARTMENT OF TRANSPORTATION

ALUMINUM LIGHT POLE

47'-6" (14.478 m)

MOUNTING HEIGHT

SCALE: NONE

DATE: 11/10/2007

DRAWN BY

CHECKED BY

BE-400

REVISION DATE: 09/02/03

PLOT DATE: 1/10/2007
 FILE NAME: c:\projects\adits\adits\adits.dgn
 USER: R. TOMSONS
 SCALE: 1/8" = 1'-0"
 USER: R. TOMSONS

BE-400

F.A.J. RTE.	SECTION	COUNTY	TOTAL SHEETS	SHEET NO.
351	3277R	COOK	541	366
STA.		TO STA.		
FED. ROAD DIST. NO.		ILLINOIS FED. AID PROJECT		

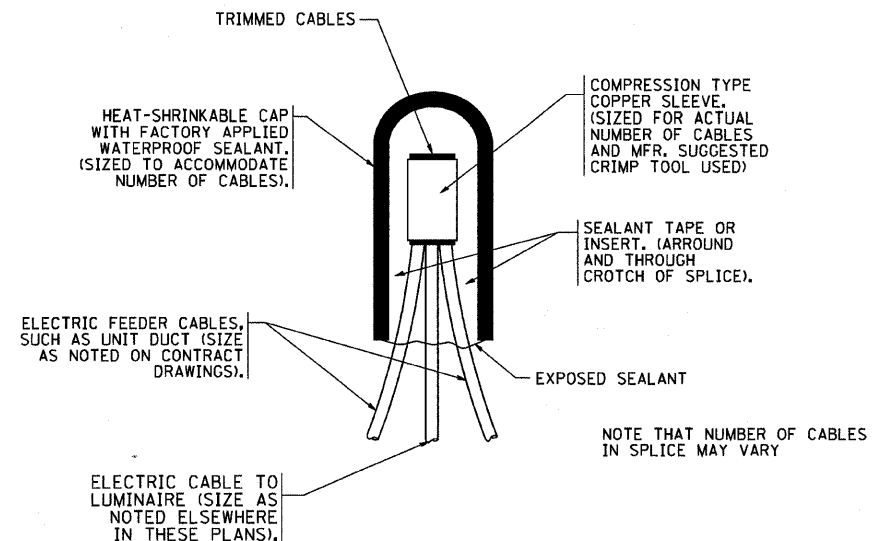

TYPICAL SPLICE DETAIL

N.T.S.

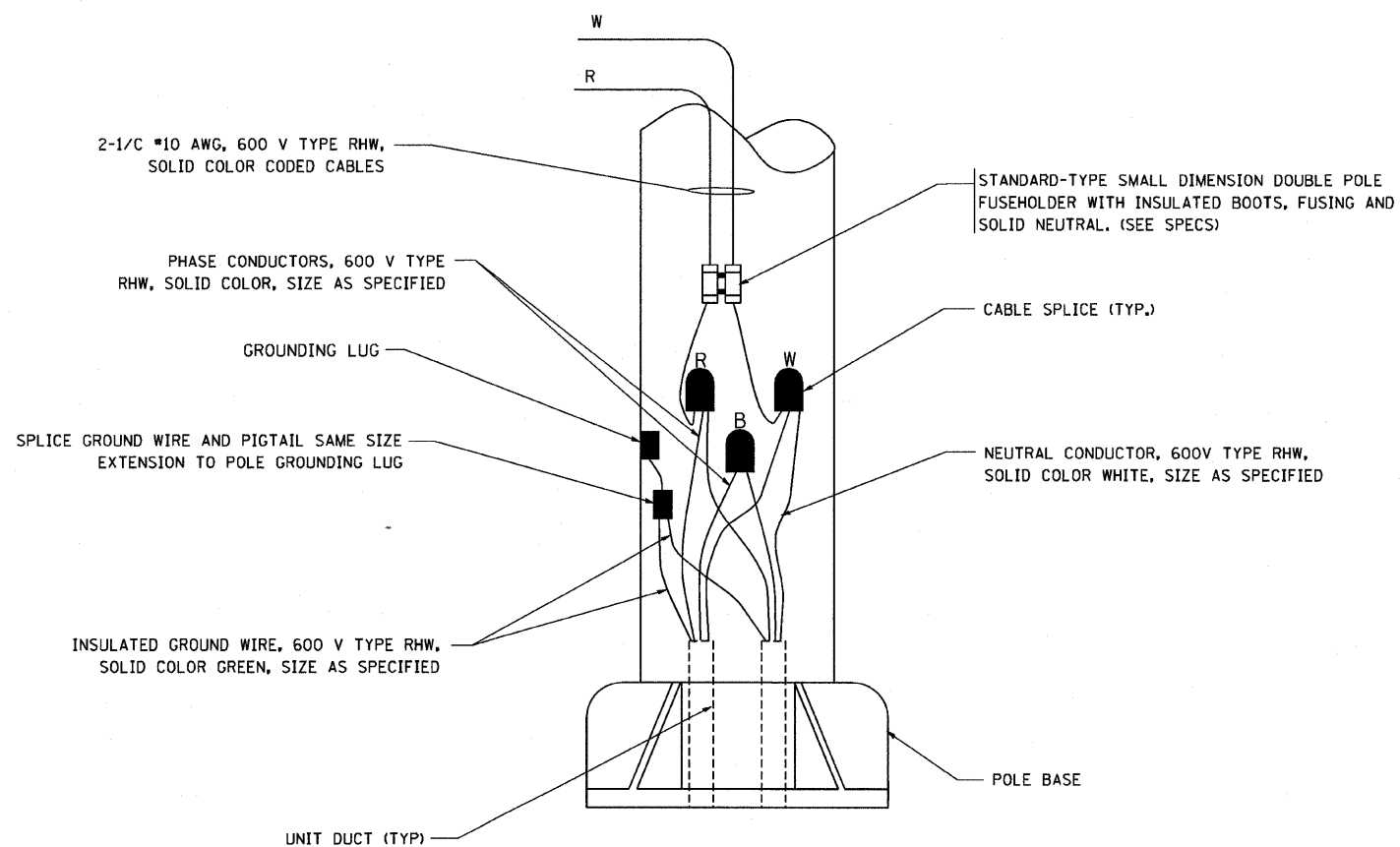

POLE WIRING DETAIL

N.T.S.

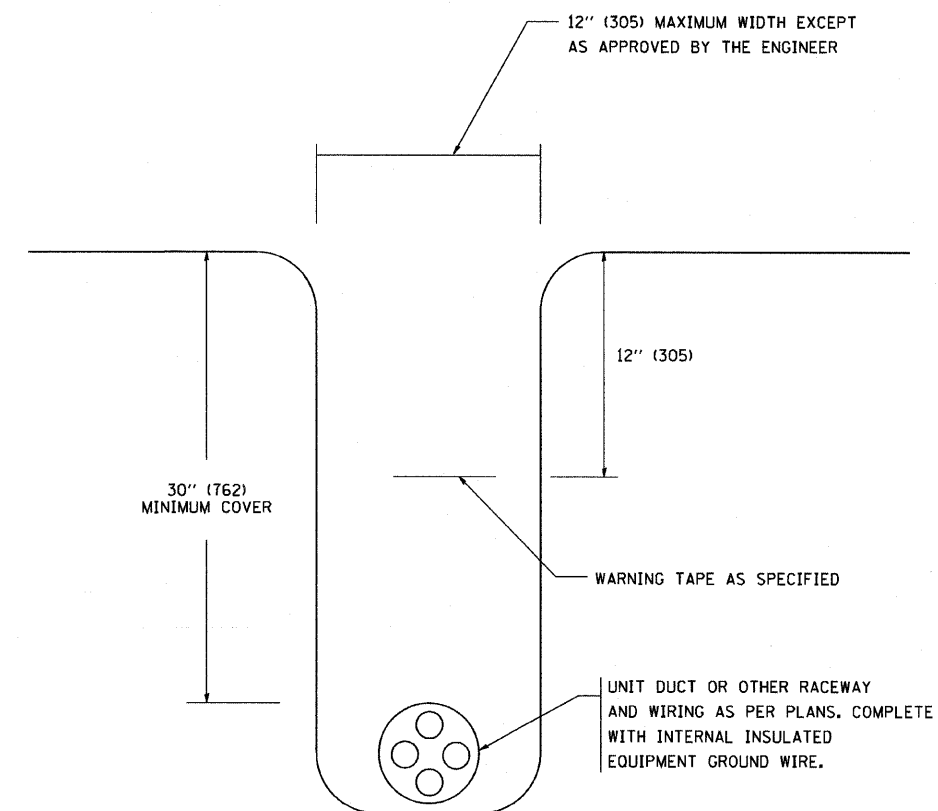

TYPICAL WIRING IN TRENCH DETAIL

N.T.S.

PLOT DATE = 4/18/2007
 FILE NAME = K:\projects\104702.dgn
 PLOT SCALE = 50/1000 = 1/20
 USER NAME = bboard

REVISIONS	
NAME	DATE
	08/08/03

ILLINOIS DEPARTMENT OF TRANSPORTATION

MISC. ELECTRICAL DETAILS
 SHEET A

SCALE: VERT. NONE
 HORIZ.

DRAWN BY
 CHECKED BY
 BE-702

F.A.D. RTE.	SECTION	COUNTY	TOTAL SHEETS	SHEET NO.
351	3277R	COOK	541	367
STA.		TO STA.		
FED. ROAD DIST. NO.		ILLINOIS FED. AID PROJECT		

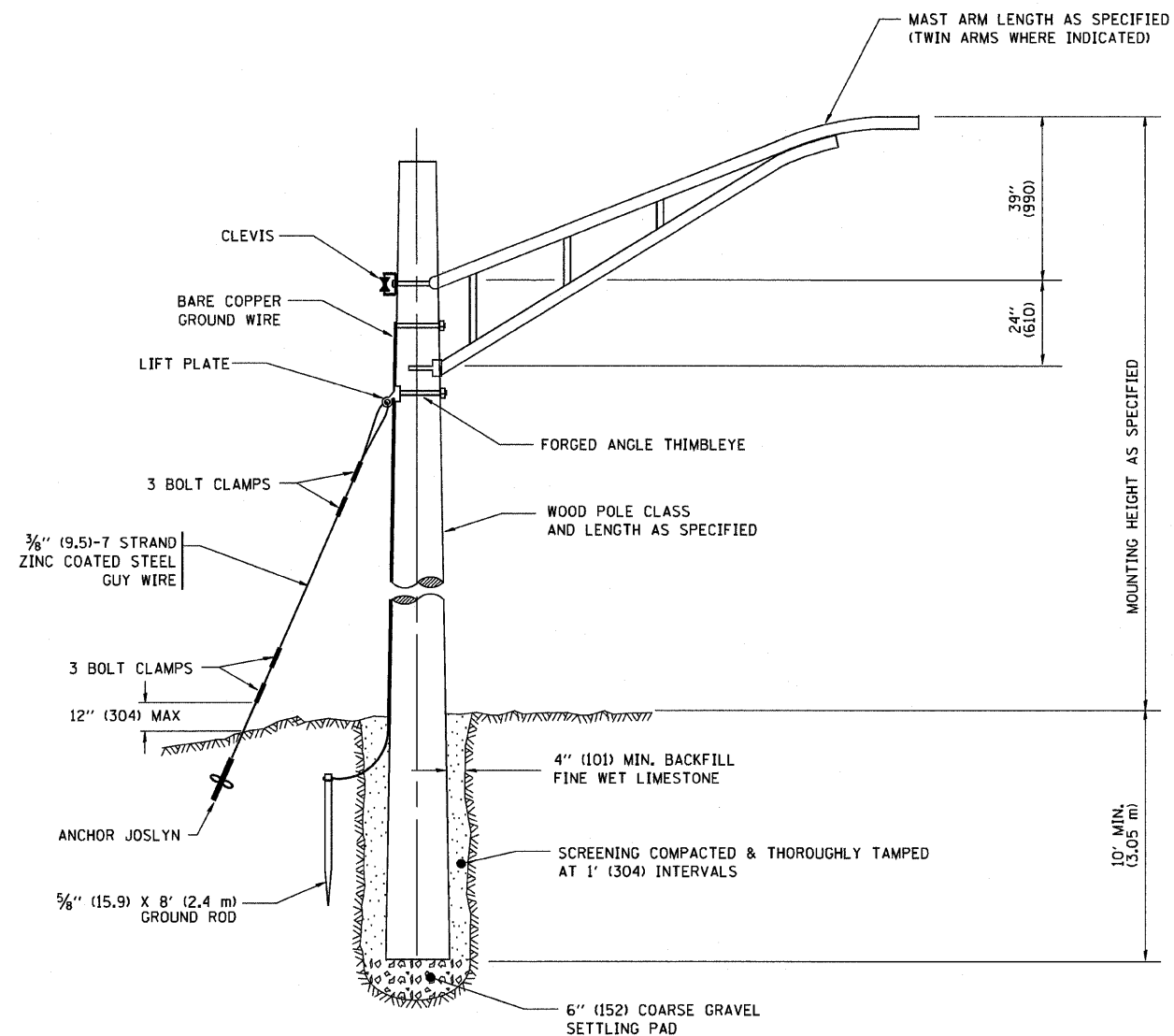

TEMPORARY LIGHT POLE DETAIL

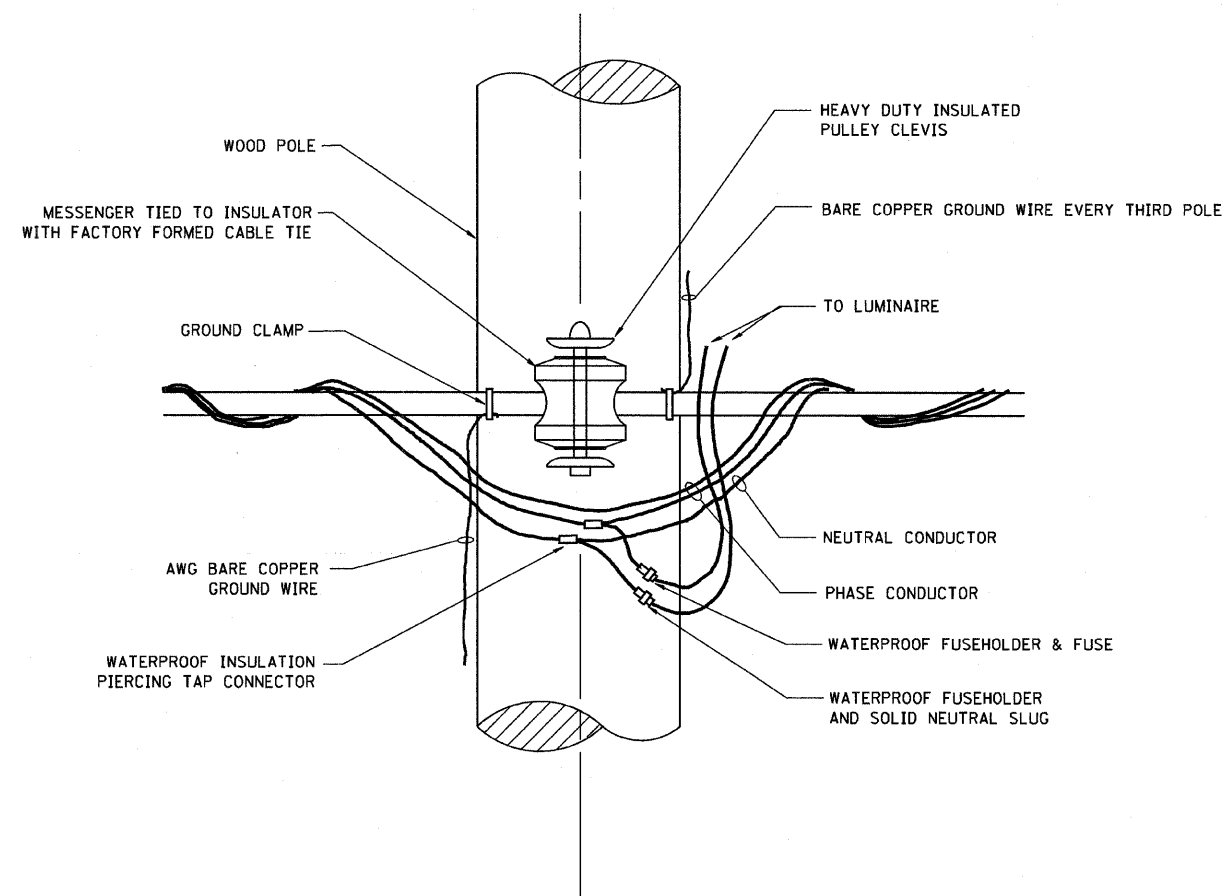

TEMPORARY LIGHT POLE ATTACHMENT DETAIL

NOTES:

1. ALL DIMENSIONS IN INCHES (MILLIMETERS) UNLESS OTHERWISE INDICATED

PLOT DATE = 4/18/2007
 FILE NAME = K:\dashed\be808.dgn
 LOT SIZE = 50000 / IN.
 USER NAME = bboard

REVISIONS	
NAME	DATE
	08/08/03

ILLINOIS DEPARTMENT OF TRANSPORTATION

TEMPORARY LIGHT POLE
 DETAILS

SCALE: VERT. NONE
 HORIZ.

DRAWN BY
 CHECKED BY
 BE-800

F.A.U. RTE.	SECTION	COUNTY	TOTAL SHEETS	SHEET NO.
351	3277R	COOK	541	368
STA.		TO STA.		
FED. ROAD DIST. NO.		ILLINOIS FED. AID PROJECT		

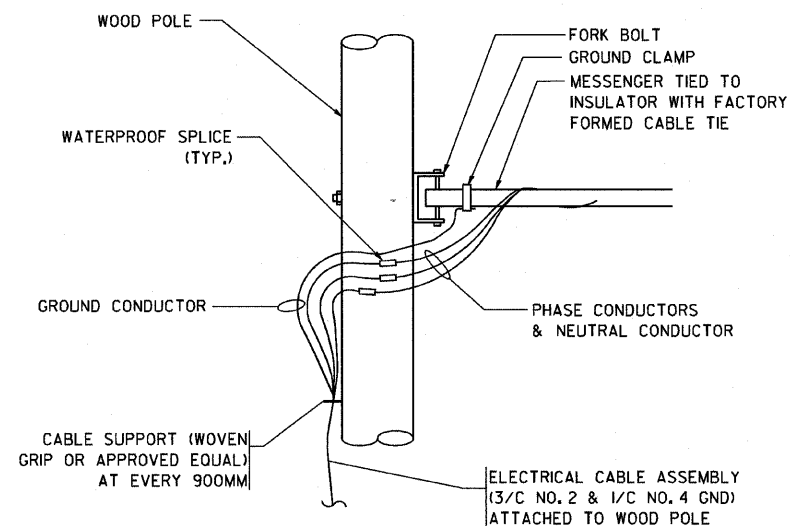

AERIAL CABLE CONNECTION DETAIL
N.T.S.

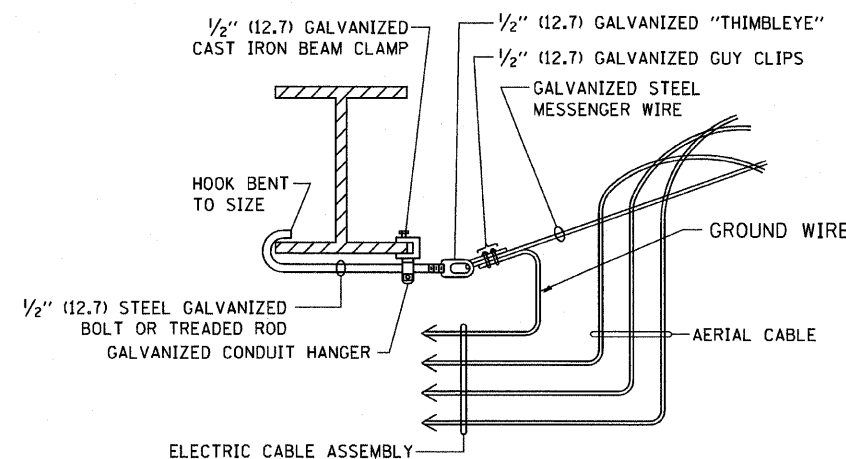

AERIAL CABLE ATTACHED TO STRUCTURE
NOT TO SCALE

NOTES:

1. ALL DIMENSIONS IN INCHES (MILLIMETERS) UNLESS OTHERWISE INDICATED.
2. SEE PROPOSED LIGHTING PLAN FOR CONDUIT, CABLE AND ROUTING.
3. THE CONTRACTOR SHALL PROVIDE INTERMEDIATE SUPPORTS TO MAINTAIN MINIMUM CLEARANCES. REFER TO AERIAL AERIAL CABLE ATTACHED TO STRUCTURE DETAIL.
4. COST OF SPLICES AND MOUNTING HARDWARE SHALL BE INCLUDED IN THE UNIT PRICE FOR AERIAL CABLE.

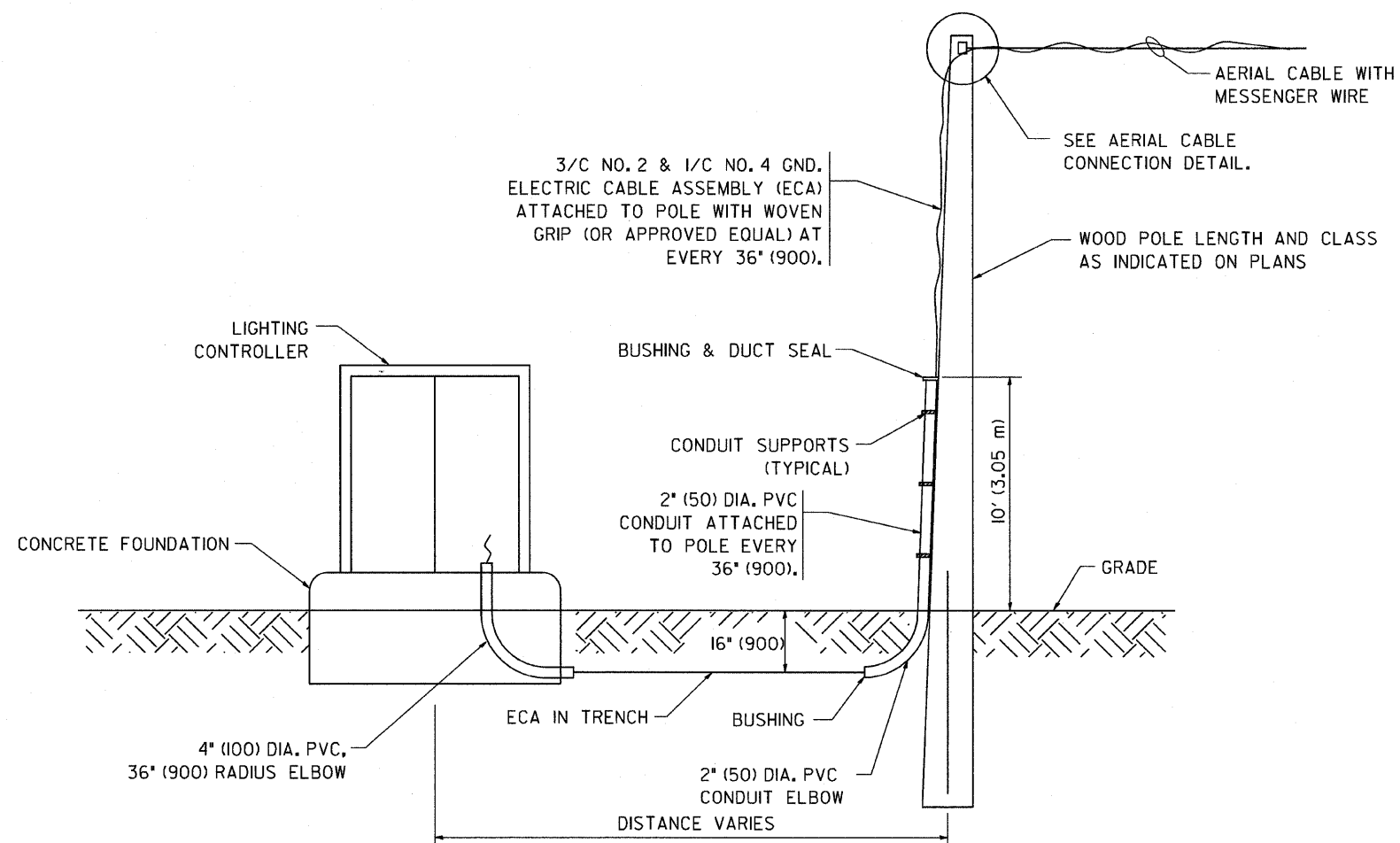

WOOD POLE TO LIGHTING CONTROLLER WIRING CONNECTION DETAIL
N.T.S.

REVISIONS	
NAME	DATE
	08/08/03

ILLINOIS DEPARTMENT OF TRANSPORTATION

TEMPORARY AERIAL CABLE INSTALLATION

SCALE: VERT. NONE
HORIZ.

DRAWN BY
CHECKED BY
BE-801

F.A.P. RTE.	SECTION	COUNTY	TOTAL SHEETS	SHEET NO.
351	3277R	COOK	541	369
STA.		TO STA.		
FED. ROAD DIST. NO.	ILLINOIS	FED. AID PROJECT		

CONTRACT NO. 60774

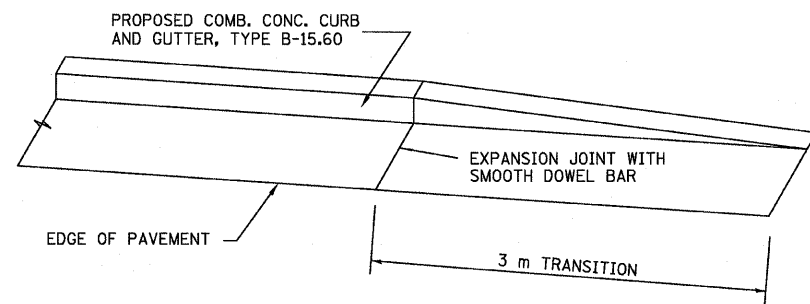

CURB TRANSITION

NOTE: TRANSITION CURB SHALL BE PAID FOR AS COMB. CONC. CURB & GUTTER, TYPE B-15.60

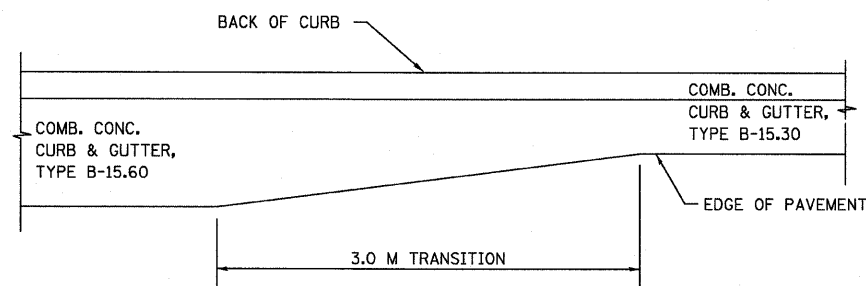

TRANSITION FROM B-15.60 TO B-15.30

NOTE: THE TRANSITION SHALL BE PAID FOR AT THE CONTRACT UNIT PRICE PER METER FOF COMB. CONC. CURB & GUTTER, TYPE B-15.60

REVISIONS	
NAME	DATE

ILLINOIS DEPARTMENT OF TRANSPORTATION
US RTE 6 FROM I-294 TO IL RTE 1
CONSTRUCTION DETAILS

DATE 01/28/09
DRAWN BY VAP
CHECKED BY JRP

F.A.U. RTE.	SECTION	COUNTY	TOTAL SHEETS	SHEET NO.
351	3277R	COOK	541	370
STA.		TO STA.		
FED. ROAD DIST. NO. 1		ILLINOIS FED. AID PROJECT		

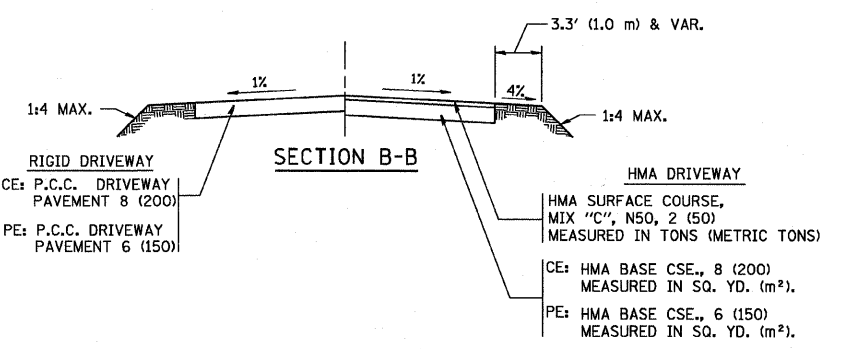
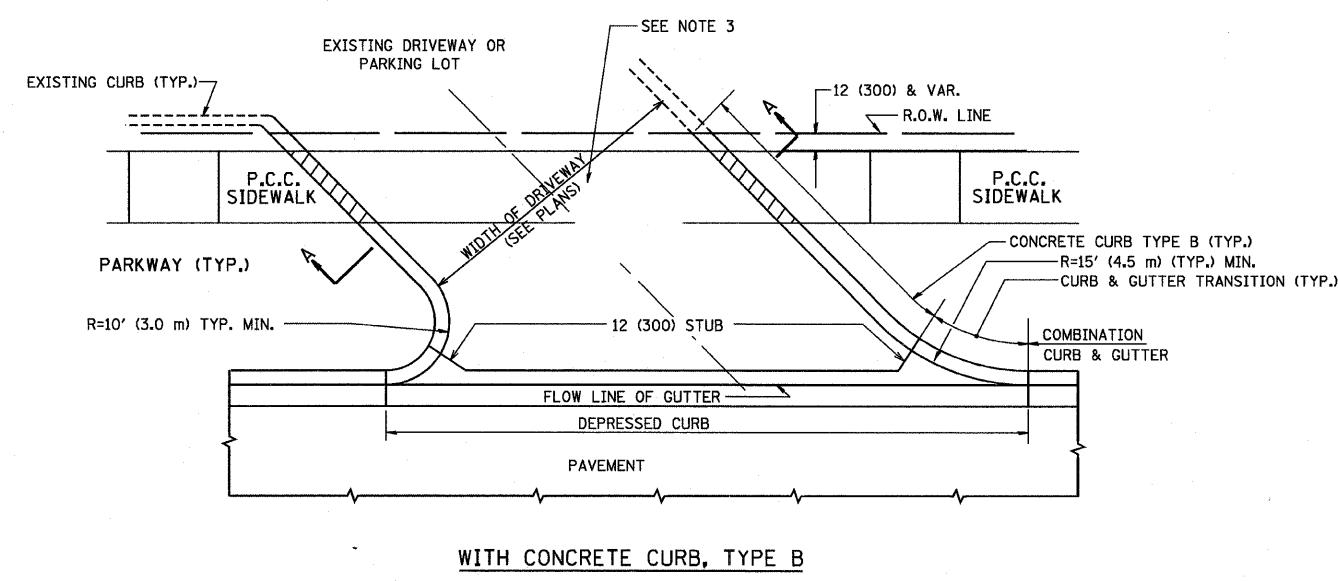
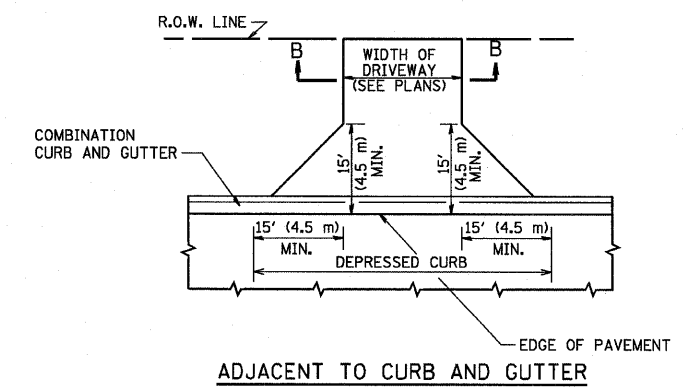
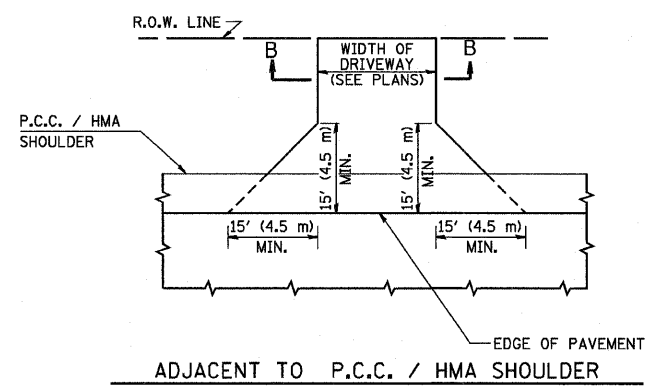
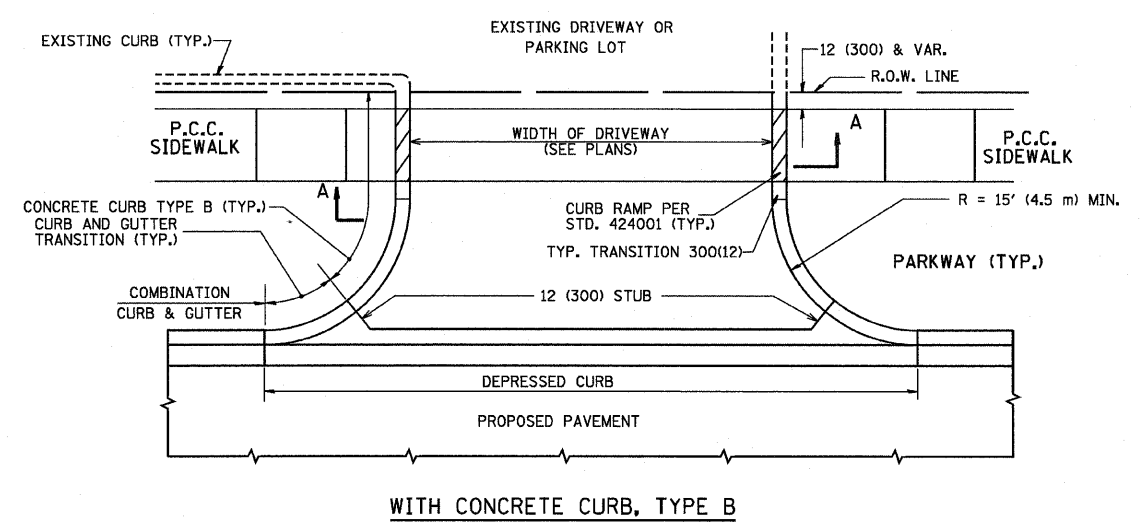

GENERAL NOTES:

DRIVEWAY SLOPES, LOCATIONS, & GEOMETRIC LAYOUT SHALL BE IN ACCORDANCE WITH THE LATEST EDITION OF THE "HANDBOOK FOR POLICY ON PERMITS FOR ACCESS DRIVEWAYS TO STATE HIGHWAYS". FOR FURTHER LAYOUT REQUIREMENTS, REFER TO ILLUSTRATIONS IN THE PERMIT HANDBOOK. DRIVEWAYS SHALL BE REPLACED IN KIND, UNLESS OTHERWISE NOTED ON THE PLANS.

COMMERCIAL DRIVEWAYS SHALL BE CONSTRUCTED WITH CONCRETE CURB, TYPE B RETURNS EXCEPT WHEN THE SIDEWALK EDGE IS 4 FEET (1.2 METERS) OR LESS FROM THE BACK OF CURB, CONSTRUCT A FLARE DRIVEWAY WITHOUT CURB.

THE RESIDENT ENGINEER SHALL CONTACT THE TRAFFIC PERMIT OFFICE AT 847/ 705-4131 FOR ANY QUESTIONS ON DRIVEWAYS SHOWN IN THE PLANS; SPECIFICALLY IN REFERENCE TO ADDITIONAL AND/OR RELOCATION/REMOVAL OF A DRIVEWAY.

COMBINATION CONCRETE CURB & GUTTER SHALL BE MEASURED STRAIGHT ACROSS THE DRIVEWAY. NO ADDITIONAL COMPENSATION WILL BE ALLOWED FOR THE CURB & GUTTER TRANSITION.

1 (25) PREFORMED EXPANSION JOINT FILLER WILL NOT BE PAID SEPARATELY, BUT SHALL BE CONSIDERED INCLUDED IN THE COST OF THE P.C.C. DRIVEWAY PAVEMENT OR P.C.C. SIDEWALK.

WHEN THE P.C.C. SIDEWALK EXTENDS THROUGH THE DRIVEWAY, THE THICKNESS OF THE SIDEWALK IN THE DRIVEWAY AREA SHALL BE THE SAME AS THE DRIVEWAY THICKNESS. SIDEWALK WILL BE PAID FOR AS P.C.C. SIDEWALK OF THE THICKNESS SPECIFIED. SIDEWALK CROSS SLOPE THRU DRIVEWAY AREA TO BE A MAXIMUM OF 1:50.

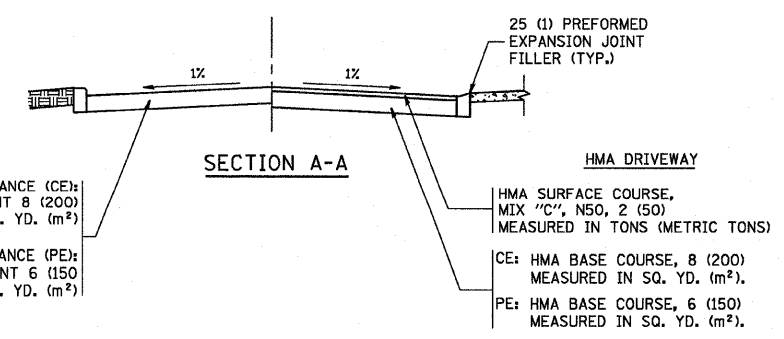

ALL DIMENSIONS ARE IN INCHES (MILLIMETERS) UNLESS OTHERWISE NOTED

REVISIONS	
NAME	DATE
R. SHAH	11-04-95
J. POLLASTRINI	08-12-96
J. POLLASTRINI	12-14-96
A. ABBAS	03-21-97
T. HOLTZ	04-08-97
M. GOMEZ	04-06-01
P. LOFLEUR	04-15-03
R. BORO	01-01-07
R. BORO	06-11-08

ILLINOIS DEPARTMENT OF TRANSPORTATION

DRIVEWAY DETAILS

DISTANCE BETWEEN R.O.W. AND FACE OF CURB & EDGE OF SHOULDER >= 15' (4.5 m)

SCALE: VERT. NONE HORIZ.

DRAWN BY

CHECKED BY

PLOT DATE = 6/12/2008
 FILE NAME = c:\pcc\projects\driveway\24-36\bd01.dgn
 PLOT SCALE = 4.5/1000 / IN.
 USER NAME = baurdl

F.A.J. RT.	SECTION	COUNTY	TOTAL SHEETS	SHEET NO.
351	3277R	COOK	541	371
STA.		TO STA.		
FED. ROAD DIST. NO. 1		ILLINOIS FED. AID PROJECT		

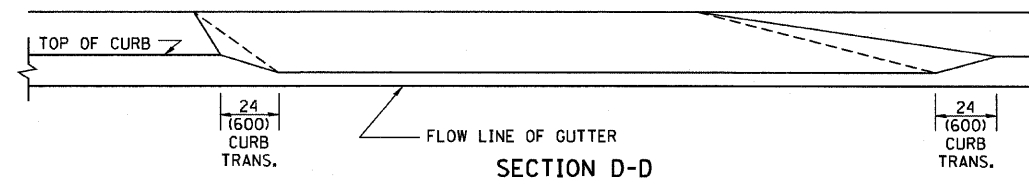
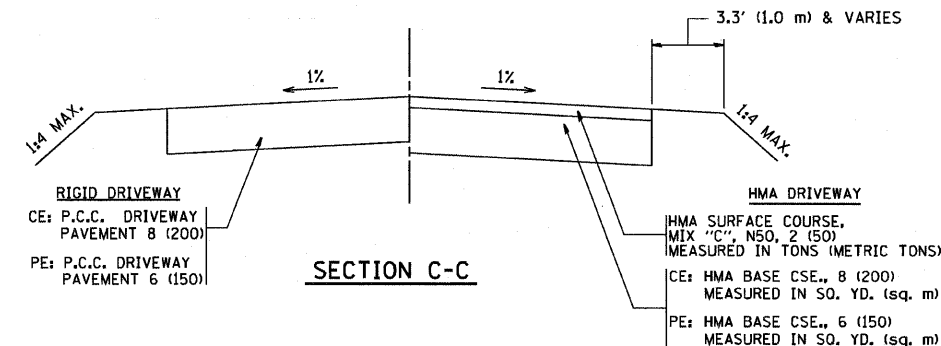
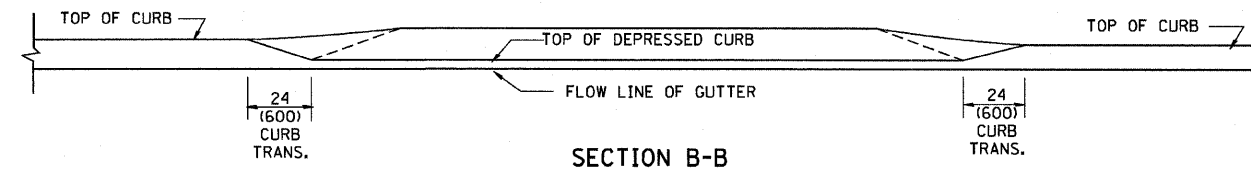
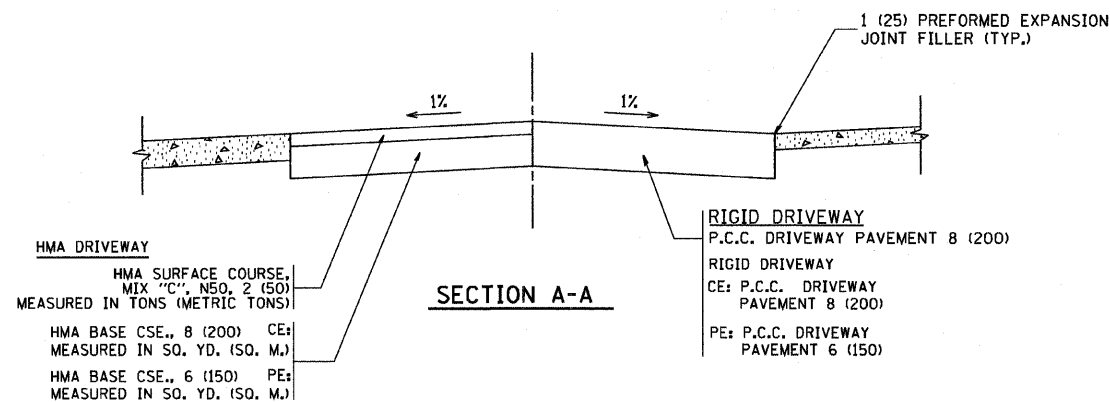
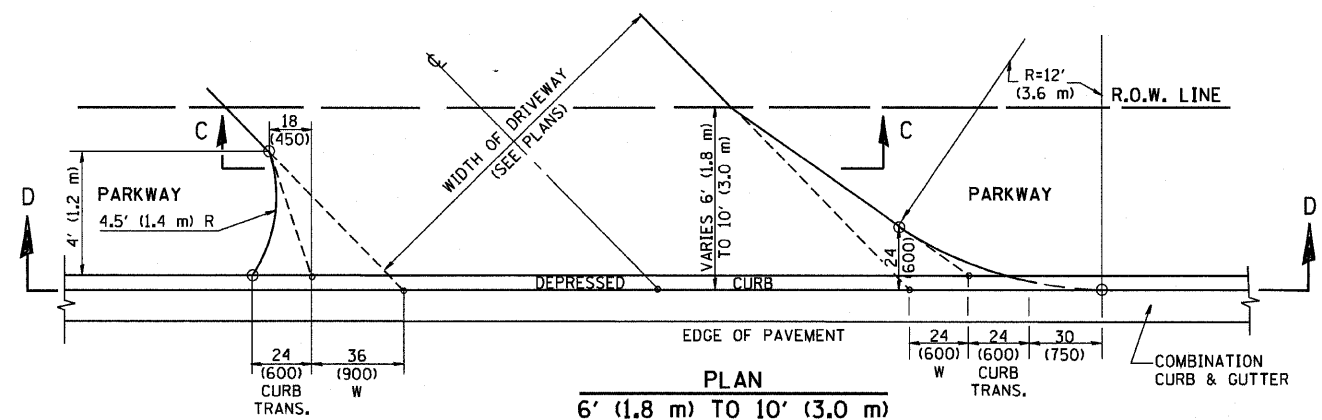
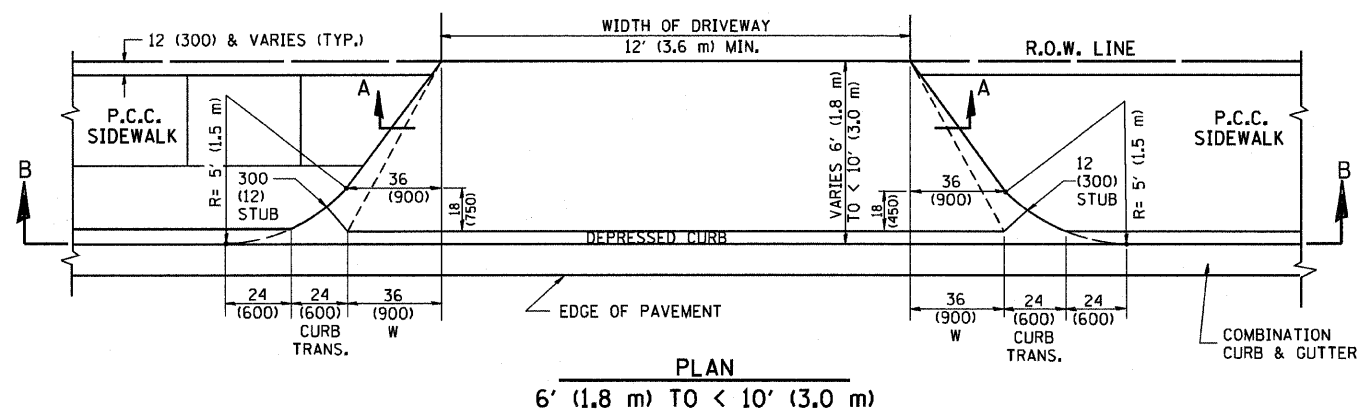
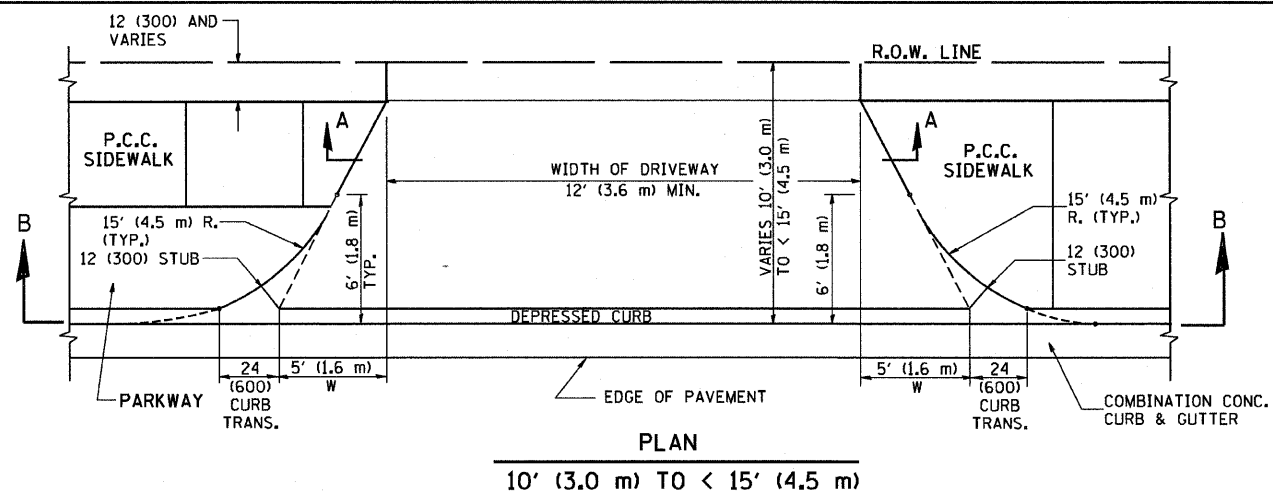

GENERAL NOTES

DRIVEWAY SLOPES, LOCATIONS, & GEOMETRIC LAYOUT SHALL BE IN ACCORDANCE WITH THE LATEST EDITION OF THE "HANDBOOK FOR POLICY ON PERMITS FOR ACCESS DRIVEWAYS TO STATE HIGHWAYS". FOR FURTHER LAYOUT REQUIREMENTS, REFER TO ILLUSTRATION 10 IN THE PERMIT HANDBOOK. WHERE SIDEWALKS EXIST, DRIVEWAYS SHALL BE REPLACED WITH RIGID PAVEMENT. WHERE NO SIDEWALKS EXIST, DRIVEWAYS SHALL BE REPLACED IN KIND. SIDEWALK CROSS SLOPE THRU DRIVEWAY AREA TO BE A MAXIMUM OF 1:50.

WHEN THE DISTANCE BETWEEN R.O.W. AND THE BACK OF CURB IS EQUAL TO OR LESS THAN 8' (2.4 m), THE P.C.C. SIDEWALK SHALL EXTEND TO THE BACK OF CURB.

THE RESIDENT ENGINEER SHALL CONTACT THE TRAFFIC PERMIT OFFICE AT 847/705-4131 FOR ANY QUESTIONS ON DRIVEWAYS SHOWN IN THE PLANS; SPECIFICALLY IN REFERENCE TO ADDITIONAL AND/OR RELOCATION/REMOVAL OF A DRIVEWAY.

COMBINATION CONCRETE CURB & GUTTER SHALL BE MEASURED STRAIGHT ACROSS THE DRIVEWAY. NO ADDITIONAL COMPENSATION WILL BE ALLOWED FOR THE CURB & GUTTER TRANSITION.

THE 1 (25) PREFORMED EXPANSION JOINT FILLER WILL NOT BE PAID SEPARATELY, BUT SHALL BE CONSIDERED INCLUDED IN THE COST OF THE P.C.C. DRIVEWAY PAVEMENT OR P.C.C. SIDEWALK.

"W" VARIES FROM 36 (900) TO 5' (1.5 m) PROPORTIONAL TO THE LENGTH (L), FROM 6' (1.8 m) TO 10' (3 m).

ALL DIMENSIONS ARE IN INCHES (MILLIMETERS) UNLESS OTHERWISE NOTED.

ILLINOIS DEPARTMENT OF TRANSPORTATION

DRIVEWAY DETAILS
DISTANCE BETWEEN ROW AND FACE OF CURB < 15' (4.5 m)

REVISIONS	
NAME	DATE
R. SHAH	11/06/95
J. POLLASTRINI	08/12/96
J. POLLASTRINI	12/14/96
A. ABBAS	03/21/97
T. HOLTZ	04/08/97
M. GOMEZ	04/06/01
P. LAFLEUR	04/15/03
R. BORO	01/01/07

SCALE: VERT. NONE
HORIZ.

DRAWN BY
CHECKED BY

F.A.U. RTE.	SECTION	COUNTY	TOTAL SHEETS	SHEET NO.
351	3277R	COOK	541	372
STA.		TO STA.		
FED. ROAD DIST. NO.	ILLINOIS	FED. AID PROJECT		

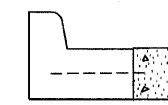
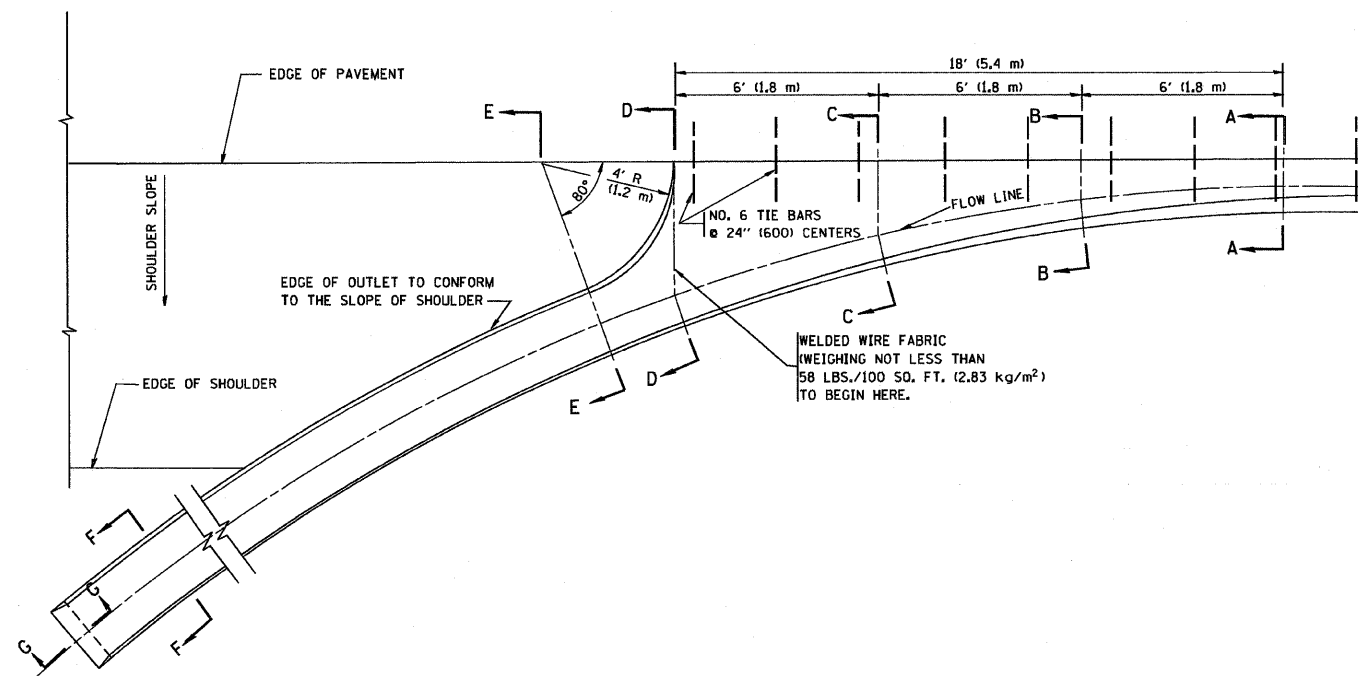

A-A *

* DIMENSIONS OF THE CURB & GUTTER AT SECTION A-A ARE SHOWN ON STATE STANDARD 606001. FOR DETAILS OF OUTLET FOR CONCRETE CURB & GUTTER, TYPE B-6.24 (B-15.60) SEE STATE STANDARD 606006.

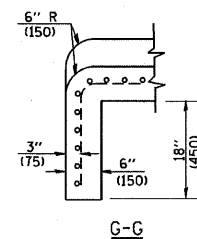
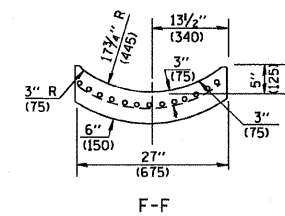
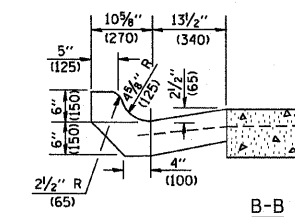
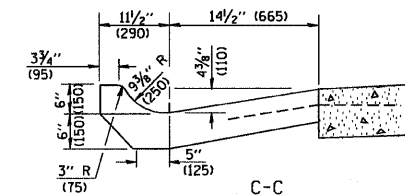
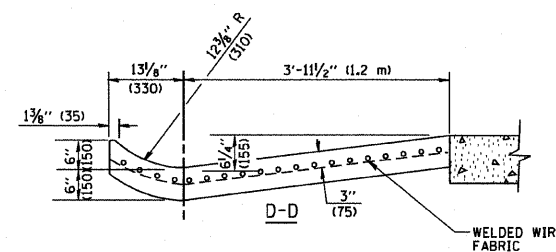
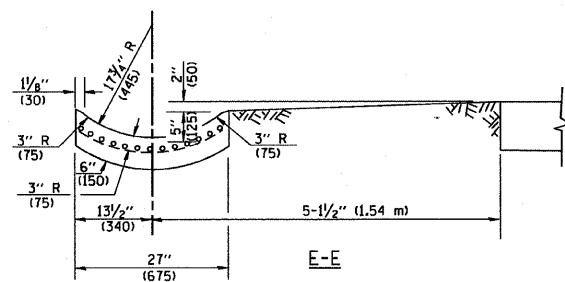

GENERAL NOTES

GUTTER OUTLET SHALL BE TIED TO THE PAVEMENT IN ACCORDANCE WITH DETAILS FOR LONGITUDINAL CONSTRUCTION JOINT SHOWN ON STANDARD 420001.

TIE BARS SHALL BE NO. 20 (NO.6) AT 24" (600) CENTERS UNLESS OTHERWISE SHOWN.

IF THE AVERAGE GRADE OF PAVEMENT FOR THE DISTANCE FROM SECTION A-A TO D-D EXCEEDS 2%, THIS DISTANCE SHALL BE INCREASED 6' (1.8 m) FOR EACH 1% INCREASE IN GRADE.

QUANTITIES

FOR SECTION A-A TO E-E AND CURTAIN WALL =
 1.25 CU. YDS. (0.96 m³) CLASS SI CONCRETE (OUTLET) FOR 9" (225) PAV'T.
 1.27 CU. YDS. (0.96 m³) CLASS SI CONCRETE (OUTLET) FOR 10" (250) PAV'T.
 FOR SECTION F-F =
 0.045 CU. YDS. (0.03 m³) CLASS SI CONCRETE PER FT. (M).

ALL DIMENSIONS ARE IN INCHES (MILLIMETERS) UNLESS OTHERWISE SHOWN.

REVISIONS	
NAME	DATE
M. DE YONG	8/4/86
R. SHAH	09/09/94
R. SHAH	10/25/94
E. GOMEZ	12/21/00

ILLINOIS DEPARTMENT OF TRANSPORTATION

OUTLET FOR CONCRETE CURB AND GUTTER

SCALE: VERT. NONE
 HORIZ.

DRAWN BY
 CHECKED BY

F.A.U. R/E.	SECTION	COUNTY	TOTAL SHEETS	SHEET NO.
351	3277R	COOK	541	373
STA.		TO STA.		
FED. ROAD DIST. NO.		ILLINOIS FED. AID PROJECT		

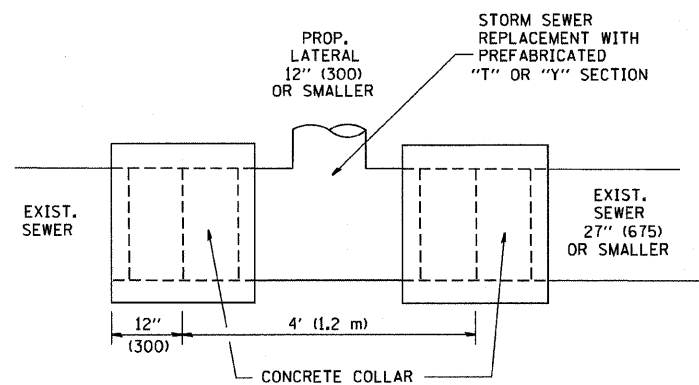

DETAIL "A"

LATERAL CONNECTION TO EXISTING SEWER OF 27" (675) OR SMALLER

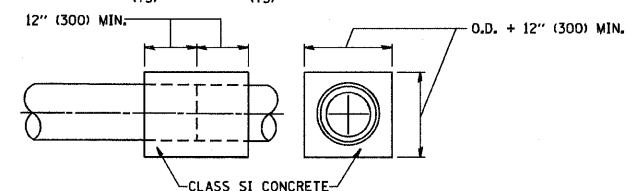
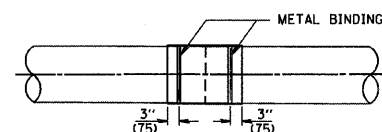
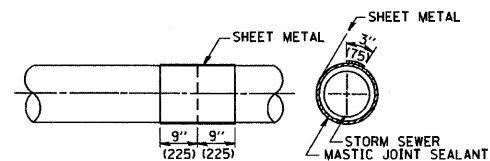
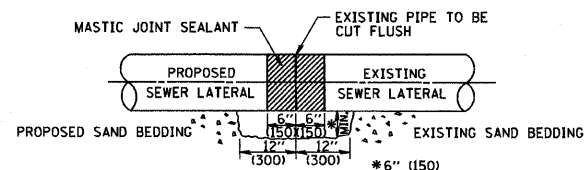

DETAIL "B"

CLASS SI CONCRETE COLLAR

CONSTRUCTION SEQUENCE

- CUT THE EXISTING END OF THE PIPE SO AS TO PRESENT A FLUSH BUTT JOINT. BRUSH AND CLEAN ALL PIPES.
- APPLY THE MASTIC JOINT SEALANT TO THE FIRST 6" (150) OF EACH PIPE.
- BUTT THE PIPES TOGETHER LEAVING A MINIMUM OF 12" x 6" (300 x 150) DEEP EXCAVATION UNDER AND AROUND EACH PIPE END.
- CUT A PIECE OF SHEET METAL GAGE NO. 19 1.1 (0.0418) 18" (450) WIDE BY THE OUTSIDE CIRCUMFERENCE OF THE PIPE PLUS 3" (75) LONG.
- WRAP THE SHEET METAL AROUND THE PIPES, 9" (225) ON EACH SIDE OF THE JOINT, STARTING AT THE TOP OF THE PIPE.
- LAP THE SHEET METAL AT LEAST 3" (75) AT THE TOP OF THE PIPE AND PLACE THE MASTIC JOINT SEALANT BETWEEN THE LAP.
- PLACE TWO METAL BANDS AROUND THE SHEET METAL AND TIGHTEN.
- WIPE OFF ANY EXCESS MASTIC JOINT SEALANT THAT OOOZES OUT FROM BETWEEN THE SHEET METAL AND THE PIPES.
- PLACE CLASS SI CONCRETE AROUND THE JOINT.

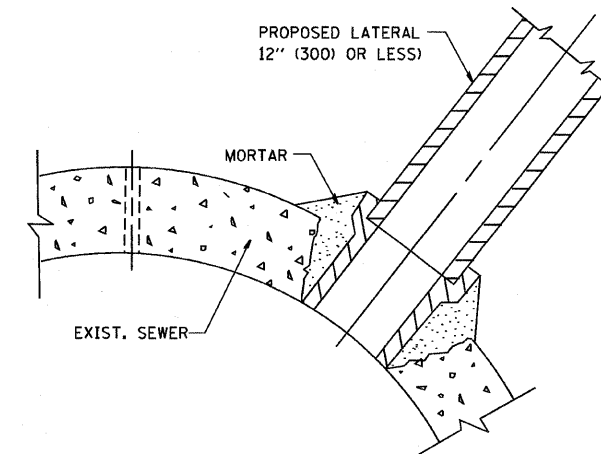

DETAIL "C"

PROPOSED LATERAL CONNECTION TO EXISTING SEWER OF 30" (750) OR LARGER

NOTES

MATERIAL

MATERIAL USED FOR THE TEE OR WYE SECTION SHALL BE COMPATIBLE WITH THE EXISTING STORM SEWER OR THE PROPOSED STORM SEWER.

CONSTRUCTION METHODS

- THIS WORK SHALL BE CONSTRUCTED IN CONFORMANCE WITH THE APPLICABLE PORTIONS OF SECTION 550 OF THE STANDARD SPECIFICATIONS.
- CONNECTION TO AN EXISTING STORM SEWER SHALL BE BY EITHER OF THE FOLLOWING METHODS:
 - PROPOSED STORM SEWER CONNECTION TO EXISTING SEWER OF 27" (675) OR SMALLER SEE DETAIL "A" AND "B".
 - PROPOSED STORM SEWER CONNECTION TO EXISTING SEWER OF 30" (750) OR LARGER SEE DETAIL "C".

IF THE EXISTING SEWER PIPE IS CRACKED, BROKEN OR OTHERWISE DAMAGED BY THE CONTRACTOR IN MAKING THE CIRCULAR OPENING, THE CONTRACTOR SHALL REPLACE THAT SECTION OF PIPE WITH PIPE EQUAL AND SIMILAR IN ALL RESPECTS TO THE PIPE IN THE EXISTING SEWER, IN A CAREFUL WORKMANLIKE MANNER, WITHOUT EXTRA COMPENSATION.

GENERAL

CARE MUST BE TAKEN TO PREVENT DEBRIS FROM ENTERING THE SEWER. ALL DEBRIS WHICH ENTERS THE SEWER MUST BE REMOVED. THE SEWER MUST BE LEFT CLEAN AND UNOBSTRUCTED UPON COMPLETION OF THE CONTRACT.

CARE MUST BE TAKEN TO PREVENT ANY PART OF THE NEW PIPE CONNECTION FROM PROJECTING INTO THE EXISTING SEWER.

BASIS OF PAYMENT

TEE OR WYE CONNECTIONS SHALL BE PAID FOR AT THE CONTRACT UNIT PRICE EACH FOR STORM SEWER TEE OR WYE OF THE TYPE AND SIZE SPECIFIED IN THE PLANS, THIS PRICE SHALL INCLUDE ALL EXCAVATION OF THE TRENCH, REMOVAL OF THE EXISTING STORM SEWER, FURNISHING AND INSTALLING THE SPECIFIED TEE OR WYE SECTION, FURNISHING AND INSTALLING THE REQUIRED CONCRETE COLLAR, AND ALL OTHER MATERIAL NECESSARY TO COMPLETE THIS WORK AS SHOWN AND SPECIFIED.

REMOVAL AND REINSTALLATION OF EXISTING STORM SEWER ADJACENT TO THE PROPOSED TEE OR WYE SECTION, FOR THE PURPOSE OF FACILITATING THE INSTALLATION OF THE TEE OR WYE SECTION, WILL NOT BE PAID FOR SEPARATELY BUT SHALL BE INCLUDED IN THE UNIT PRICE BID FOR THE WORK.

TRENCH BACKFILL, EXCAVATION IN ROCK AND REMOVAL AND REPLACEMENT OF UNSUITABLE MATERIAL BELOW PLAN BEDDING GRADE WILL BE PAID FOR SEPARATELY.

CONCRETE COLLAR FOR CONNECTING A PROPOSED STORM SEWER TO AN EXISTING STORM SEWER WILL NOT BE PAID FOR SEPARATELY BUT SHALL BE INCLUDED IN THE COST OF THE PROPOSED STORM SEWER.

ALL DIMENSIONS ARE IN INCHES (MILLIMETERS) UNLESS OTHERWISE SHOWN.

REVISIONS	
NAME	DATE
M. DE YONG	07/25/90
M. DE YONG	02/05/92
M. DE YONG	05/08/92
R. SHAH	09/09/94
R. SHAH	10/25/94
R. SHAH	06/12/96

ILLINOIS DEPARTMENT OF TRANSPORTATION

DETAIL OF STORM SEWER CONNECTION TO EXISTING SEWER

SCALE: VERT. NONE
HORIZ.

DRAWN BY
CHECKED BY

BD500-01 (BD-7)

F.A.J. RTE.	SECTION	COUNTY	TOTAL SHEETS	SHEET NO.
351	3277R	COOK	541	374
STA.		TO STA.		
FED. ROAD DIST. NO. 1		ILLINOIS	FED. AID PROJECT	

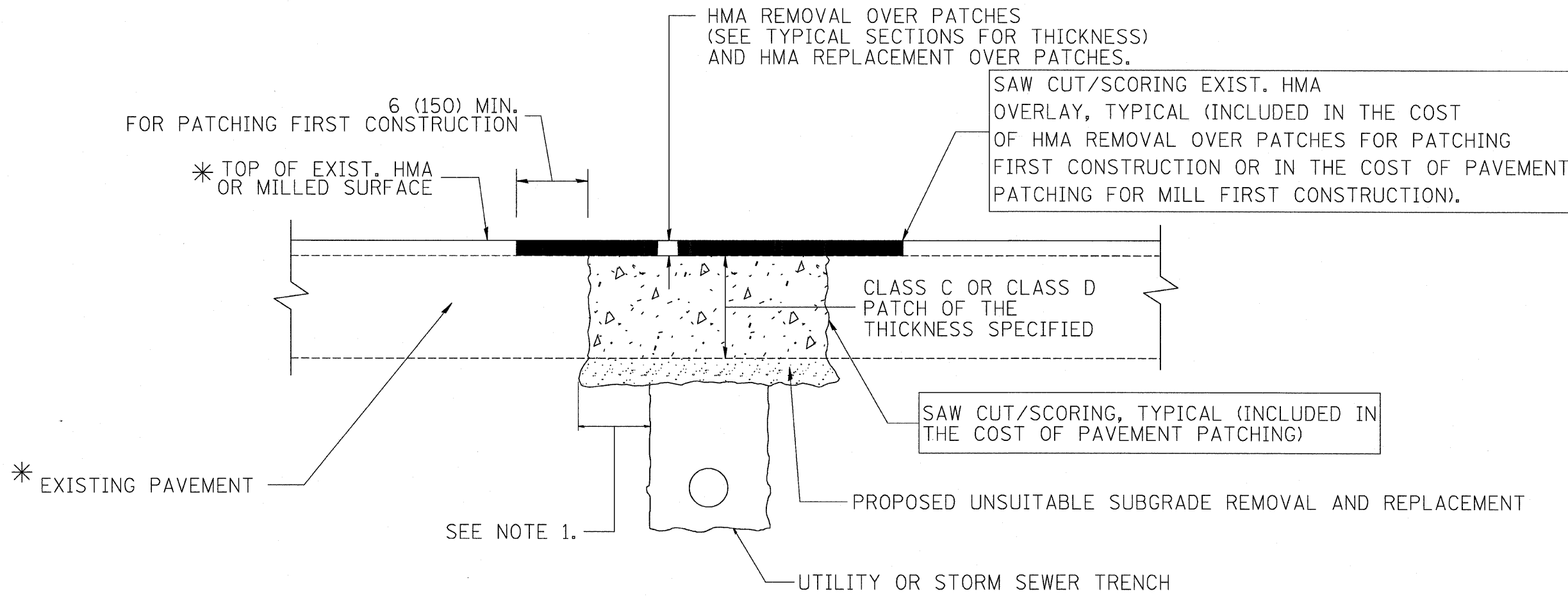

* SEE TYPICAL SECTIONS FOR THICKNESS AND MATERIALS

NOTES:

1. THE WIDTH OF THE FULL DEPTH PATCH OVER A TRENCH SHALL BE 12 (300) WIDER ON EACH SIDE OF THE TRENCH.
2. FOR METHOD OF MEASUREMENT AND BASIS OF PAYMENT, SEE RECURRING SPECIAL PROVISION "PATCHING WITH HOT-MIX ASPHALT OVERLAY REMOVAL".

SEQUENCE OF CONSTRUCTION (PATCHING FIRST)

1. REMOVE THE EXISTING HMA MATERIAL OVER THE AREA TO BE PATCHED.
2. REMOVE AND REPLACE WITH CLASS C OR D PATCH.
3. REPLACE HMA MATERIAL OVER THE AREA TO BE PATCHED.

SEQUENCE OF CONSTRUCTION (MILLING FIRST)

1. MILL HMA FIRST IF THERE IS AT LEAST 4 1/2 INCHES OR MORE OF HMA MATERIAL ON TOP OF THE EXISTING PAVEMENT OR IF THE PAVEMENT IS FULL DEPTH HMA. A MINIMUM OF 2 INCHES OF HMA MATERIAL SHALL BE IN PLACE AFTER MILLING.
2. REMOVE AND REPLACE WITH FULL DEPTH CLASS D PATCHES TO TOP OF MILLED SURFACE.

ALL DIMENSIONS ARE IN INCHES (MILLIMETERS) UNLESS OTHERWISE SHOWN.

REVISIONS	
NAME	DATE
R. SHAH	01/14/95
R. SHAH	03/23/95
R. SHAH	04/24/95
A. HOUSEH	03/15/96
A. ABBAS	03/21/97
A. ABBAS	01/20/98
ART ABBAS	04/27/98
R. BORO	01/01/07
R. BORO	09/04/07
K. ENG	10/27/08

ILLINOIS DEPARTMENT OF TRANSPORTATION

PAVEMENT PATCHING FOR HMA SURFACED PAVEMENT

SCALE: VERT. NONE
HORIZ.

DRAWN BY
CHECKED BY
BD400-04 (BD-22)

F.A.U. RTE.	SECTION	COUNTY	TOTAL SHEETS	SHEET NO.
351	3277R	COOK	541	375
STA.		TO STA.		
FED. ROAD DIST. NO. 1		ILLINOIS FED. AID PROJECT		

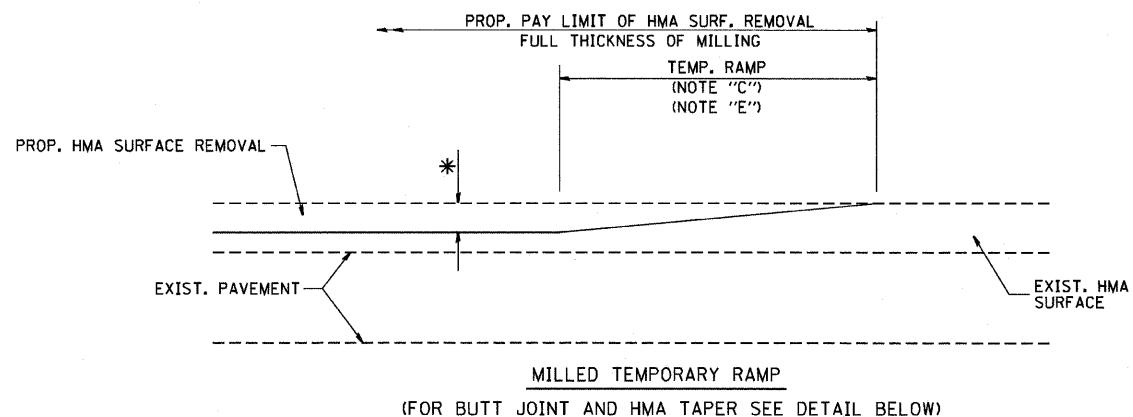

OPTION 1

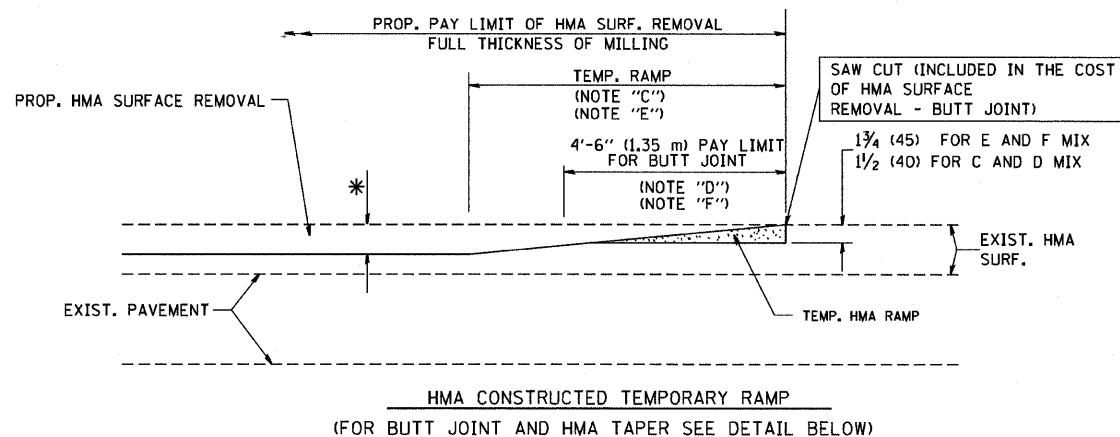

OPTION 2
TYPICAL TEMPORARY RAMP

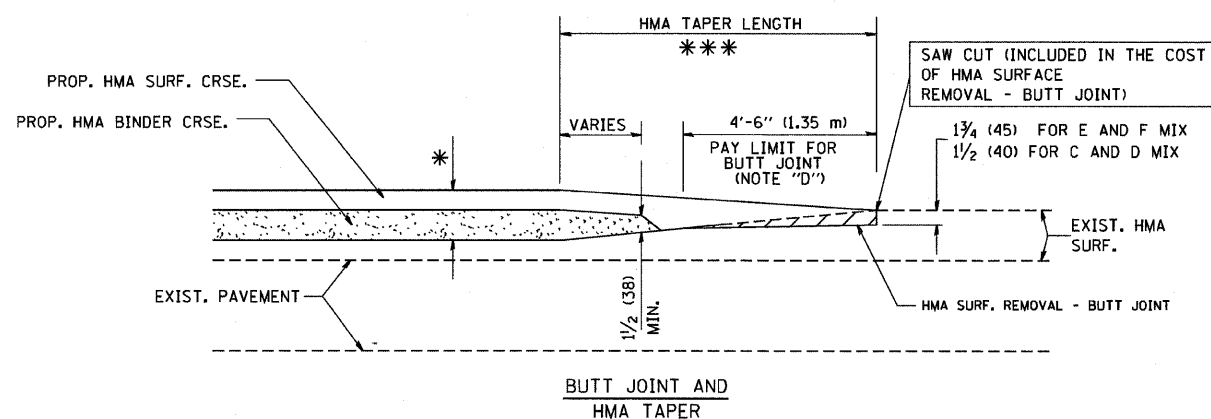

TYPICAL BUTT JOINT AND HMA TAPER
FOR MILLING AND RESURFACING

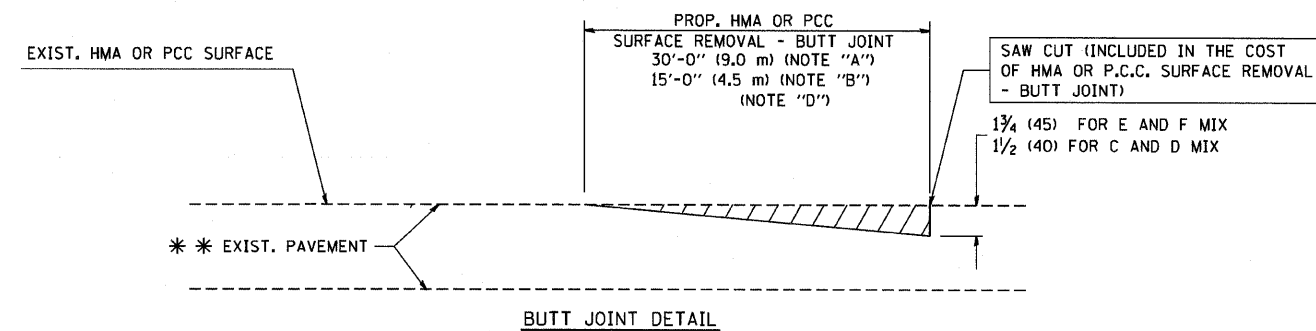

BUTT JOINT DETAIL

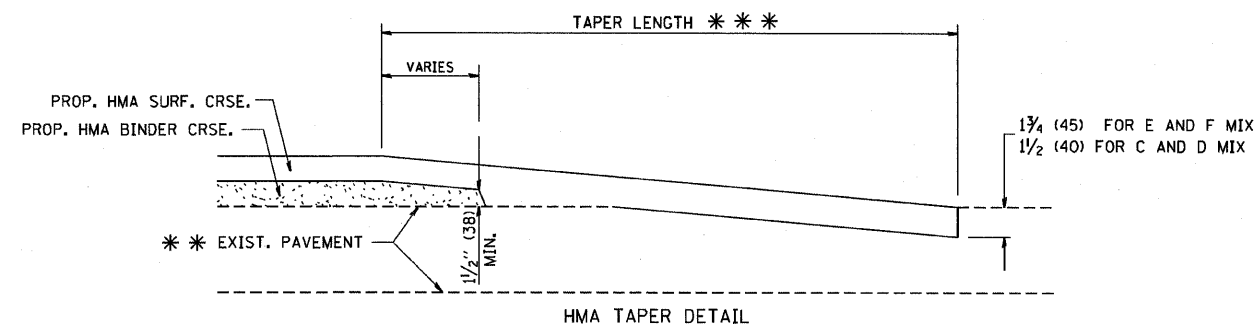

HMA TAPER DETAIL

TYPICAL BUTT JOINT AND HMA TAPER
FOR RESURFACING ONLY

*** PC CONCRETE, HMA OR HMA RESURFACED PAVEMENT.

NOTES

- A: MAINLINE ROADWAYS AND MAJOR SIDE ROADS.
- B: MINOR SIDE ROADS.
- C: THE TEMP. RAMP SHALL BE CONSTRUCTED IMMEDIATELY UPON REMOVAL OF THE EXISTING HMA SURFACE.
- D: THE BUTT JOINT SHALL BE CONSTRUCTED IMMEDIATELY PRIOR TO PLACING THE PROPOSED HMA COURSES.
- E: TAPER THE TEMP. RAMP AT A RATE OF 3'-0" (900 mm) PER 1 INCH (25 mm) OF MILLING THICKNESS.
- F: INSTALLATION AND REMOVAL OF THE 4'-6" (1.35 m) TEMP. RAMP IS INCLUDED IN COST OF HMA SURFACE REMOVAL - BUTT JOINT
- G: SEE ARTICLE 406.08 AND 406.14 OF THE STANDARD SPECIFICATIONS FOR "HMA AND/OR PCC SURFACE REMOVAL, BUTT JOINT".
- * SEE TYPICAL SECTIONS FOR MILLING THICKNESS.

*** 20'-0" (6.1 m) PER 1 (25) RESURFACING (NOTE "A")
10'-0" (3.0 m) PER 1 (25) RESURFACING (NOTE "B")

ALL DIMENSIONS ARE IN INCHES (MILLIMETERS) UNLESS OTHERWISE SHOWN.

BASIS OF PAYMENT:

THE BUTT JOINT WILL BE PAID FOR AT THE CONTRACT UNIT PRICE PER SQUARE YARD (SQUARE METER) FOR "HOT-MIX ASPHALT SURFACE REMOVAL - BUTT JOINT" OR FOR "PORTLAND CEMENT CONCRETE SURFACE REMOVAL - BUTT JOINT".

REVISIONS	
NAME	DATE
M. DE YONG	6-13-90
M. DE YONG	7-3-90
M. DE YONG	3-27-92
R. SHAH	09/09/94
R. SHAH	10/25/94
A. ABBAS	03/21/97
M. GOMEZ	04/06/01
R. BORO	01/01/07

ILLINOIS DEPARTMENT OF TRANSPORTATION

BUTT JOINT AND
HMA TAPER
DETAILS

SCALE: VERT. NONE
HORIZ.

DRAWN BY
CHECKED BY

BD400-05 (VI=BD32)

F.A.J. RTE.	SECTION	COUNTY	TOTAL SHEETS	SHEET NO.
351	3277R	COOK	541	376
STA.		TO STA.		
FED. ROAD DIST. NO.		ILLINOIS FED. AID PROJECT		

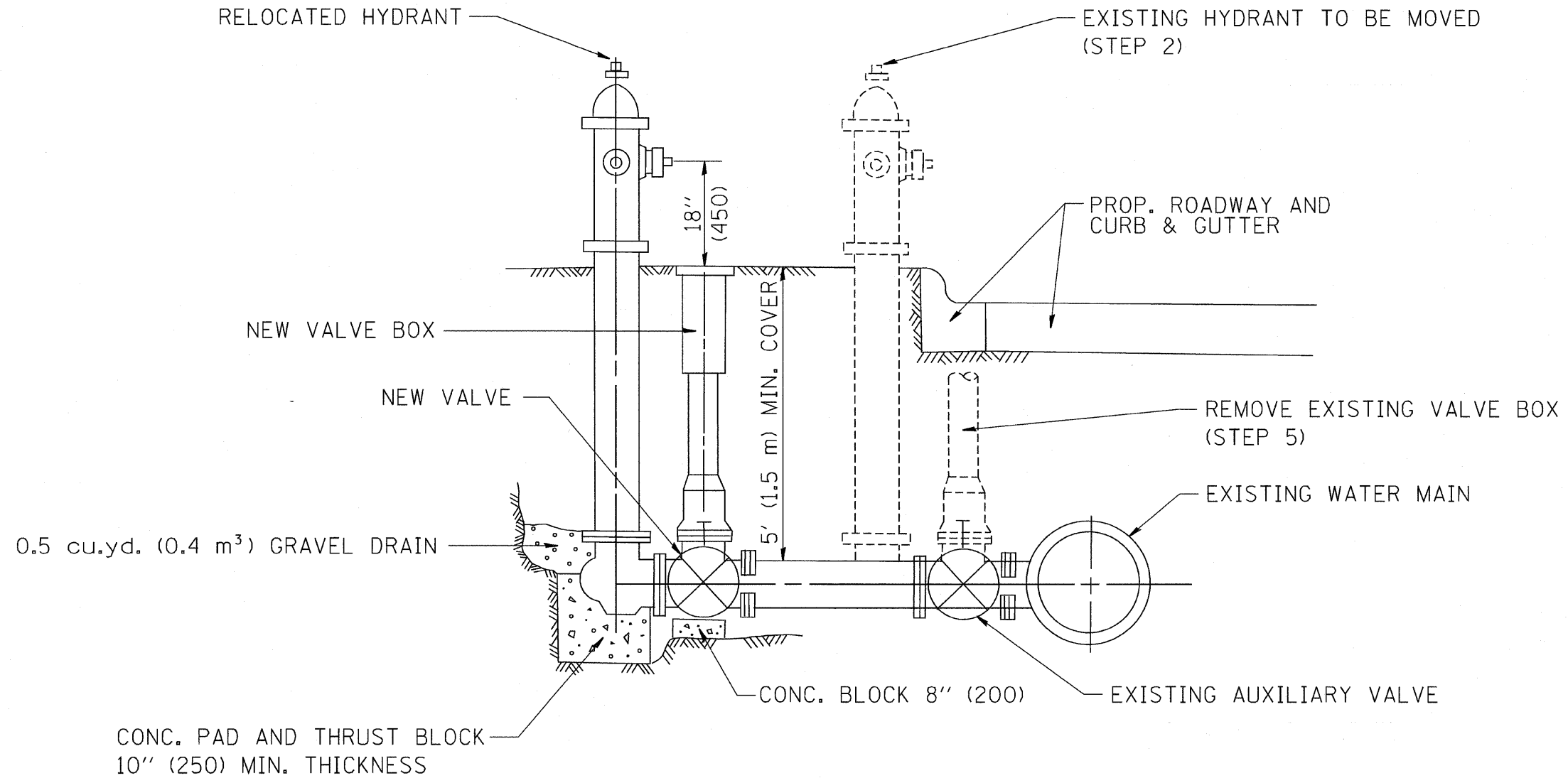

SEQUENCE OF CONSTRUCTION:

1. CLOSE EXISTING VALVE.
2. REMOVE EXISTING HYDRANT.
3. INSTALL HYDRANT EXTENSION AND NEW VALVE.
4. RELOCATE EXISTING HYDRANT.
5. OPEN EXISTING VALVE, REMOVE BOX.
6. BACKFILL.
7. FLUSH AND TEST FOR CHLORIDE RESIDUAL AND PROVIDE TEST.

ALL WORK TO BE DONE IN ACCORDANCE WITH ARTICLE 564 OF THE STANDARD SPECIFICATIONS. NEW VALVE AND BOX SHALL BE SAME MAKE AND MODEL AS EXISTING.

FIRE HYDRANT TO BE MOVED

ALL DIMENSIONS ARE IN INCHES (MILLIMETERS) UNLESS OTHERWISE SHOWN.

REVISIONS	
NAME	DATE
R. SHAH	09/09/94
R. SHAH	10/25/94

ILLINOIS DEPARTMENT OF TRANSPORTATION

FIRE HYDRANT TO BE MOVED

SCALE: VERT. NONE
HORIZ.

DRAWN BY
CHECKED BY

F.A.U. RTR.	SECTION	COUNTY	TOTAL SHEETS	SHEET NO.
351	3277R	COOK	541	377
STA.		TO STA.		
FED. ROAD DIST. NO.		ILLINOIS FED. AID PROJECT		

GENERAL NOTES

ALTERNATE MATERIAL FOR THE WALLS MAY BE CONCRETE MASONRY UNITS, PRECAST REINFORCED CONCRETE SECTIONS OR CAST-IN-PLACE CONCRETE. THE CAST IRON STEPS AS DETAILED HEREON ARE TYPICAL. STEPS OF OTHER DESIGN AND MATERIAL THAT CONFORM TO THE MINIMUM REQUIREMENTS OF THE STEPS SHOWN MAY BE USED WHEN APPROVED BY THE ENGINEER.

CAST IRON STEPS SHALL BE GRAY IRON CONFORMING TO THE REQUIREMENTS OF ARTICLE 1006.14 OF THE STANDARD SPECIFICATIONS.

STEPS SHALL BE EMBEDDED INTO THE WALL A MINIMUM OF THREE (3) INCHES. STEPS SHALL NOT BE EXTENDED ON THE OUTSIDE.

STEPS SHALL BE OMITTED FOR WORK IN COOK COUNTY WHEN THE DEPTH OF THE MANHOLE IS TEN (10') OR LESS.

IN ADDITION TO THE REQUIREMENTS OF ARTICLE 612.13 OF THE STANDARD SPECIFICATIONS, THE CONTRACT UNIT PRICE FOR MANHOLES, TYPE A, 7'-DIAMETER SHALL INCLUDE THE SAND CUSHION WHEN REQUIRED, FURNISHING AND INSTALLING STEPS WHEN REQUIRED, FURNISHING AND COMPACTING THE SPECIFIED BACKFILL MATERIAL, AND FURNISHING AND INSTALLING FLAT SLAB TOP.

PRECAST FLAT SLAB TOP SHALL CONFORM TO ARTICLES 505.01 THRU 505.05 OF THE STANDARD SPECIFICATIONS EXCEPT THAT THE CONCRETE STRENGTH SHALL BE 4,000 PSI AFTER 28 DAYS. REINFORCEMENT BARS AND WELDED WIRE FABRIC SHALL CONFORM TO THE REQUIREMENTS OF ARTICLE 1006.10. ONLY GRADE 60 REINFORCEMENT BARS WILL BE PERMITTED.

BOTTOM SLAB SHALL BE REINFORCED BY EITHER REINFORCEMENT BARS OR WELDED WIRE FABRIC. THE MINIMUM REINFORCEMENT SHALL BE 0.46 SQUARE INCH PER LINEAR FOOT IN BOTH DIRECTIONS.

JOINT CONFIGURATION AND DIMENSIONS OF FLAT SLAB TOP SHALL MATCH AND FIT THE RISER JOINT DETAIL.

LIFTING DEVICES SHALL BE APPROVED BY THE ENGINEER.

ALTERNATE MATERIALS FOR RISERS	T (MIN.)
CONCRETE MASONRY UNITS	5"
PRECAST REINFORCED CONCRETE SECTIONS	4"
CAST-IN-PLACE CONCRETE	6"

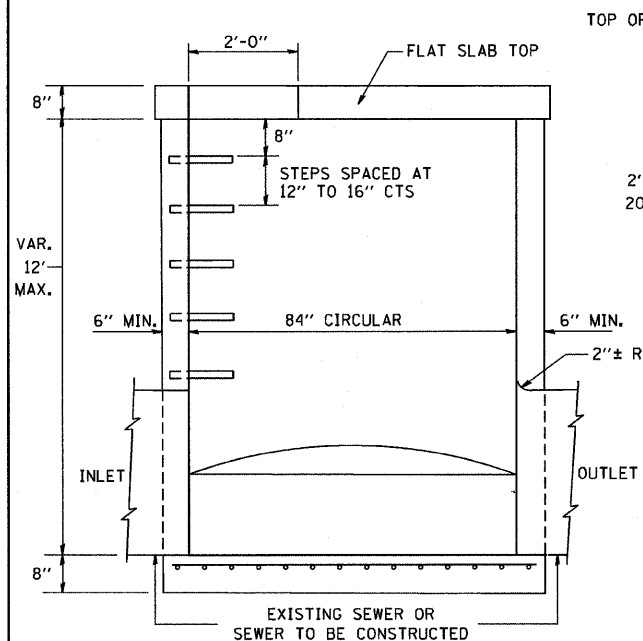

ELEVATION

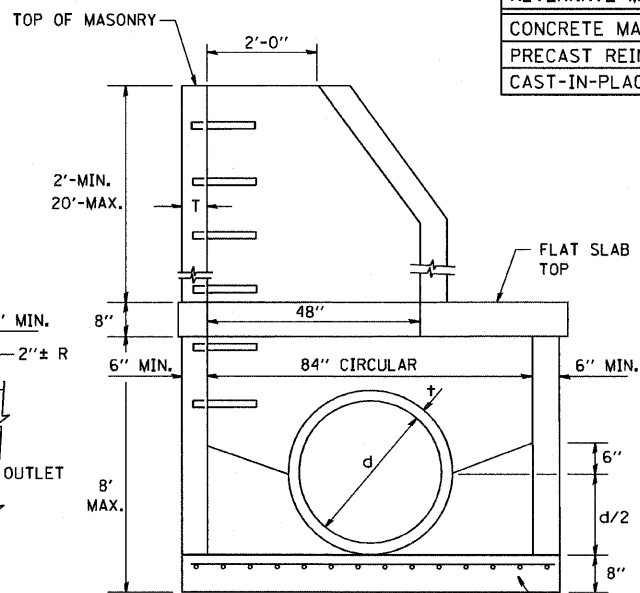

ELEVATION

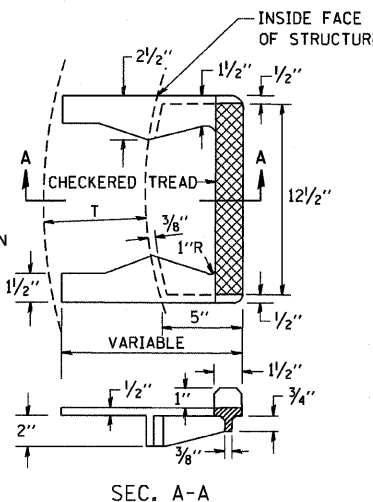
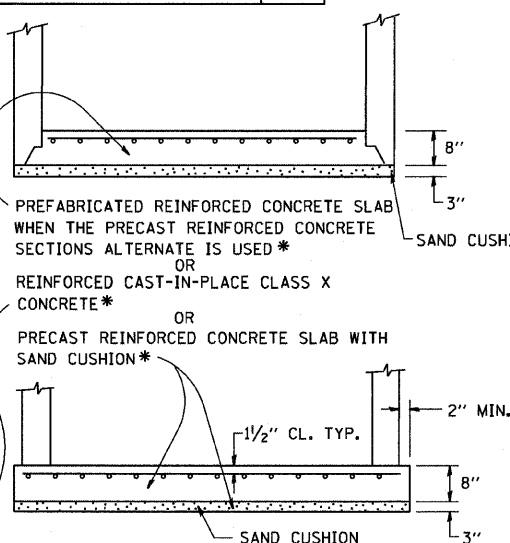

CAST IRON STEPS

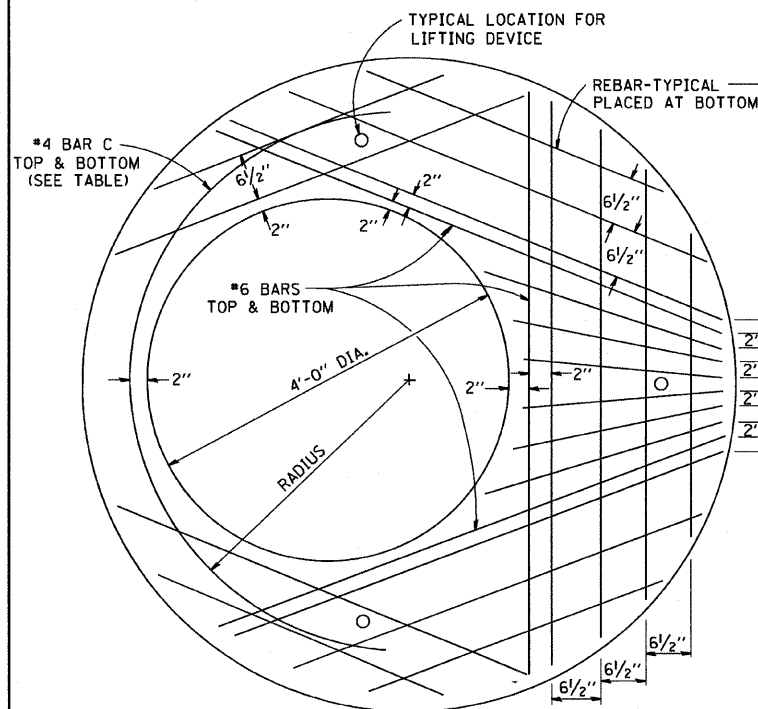

PLAN

SHOWING REBAR REINFORCEMENT

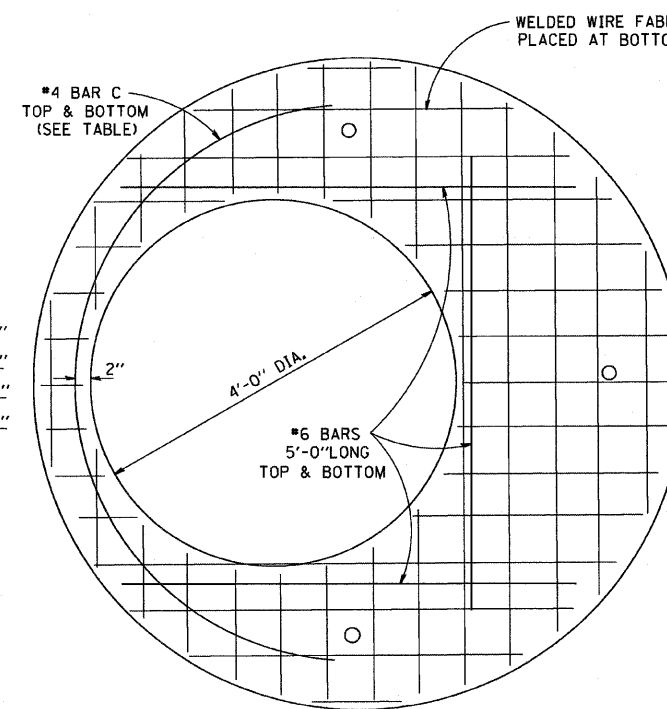
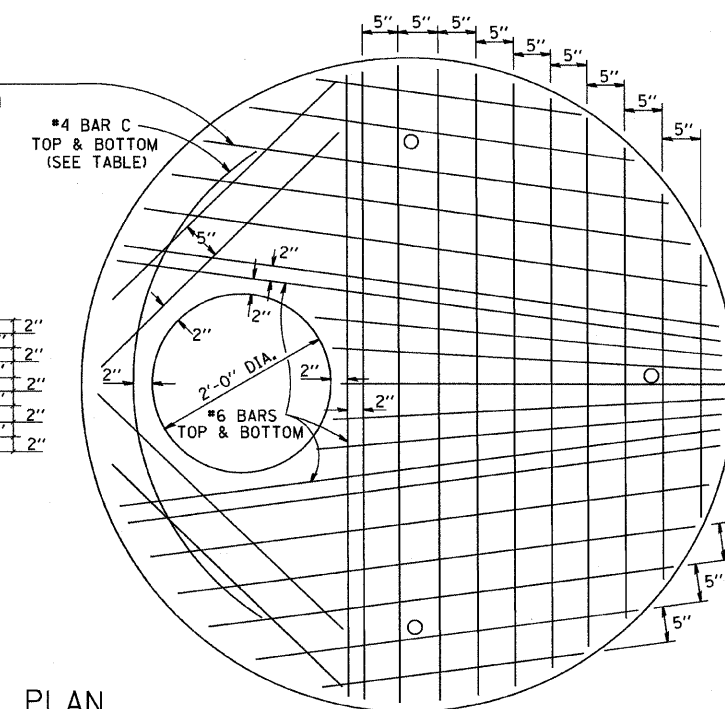

PLAN

SHOWING WELDED WIRE FABRIC REINFORCEMENT

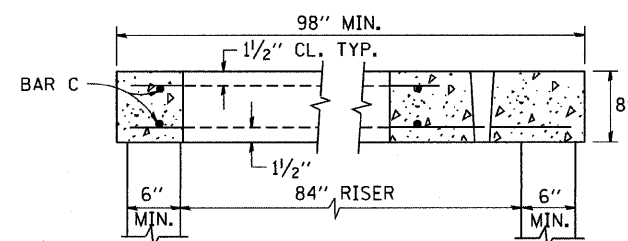
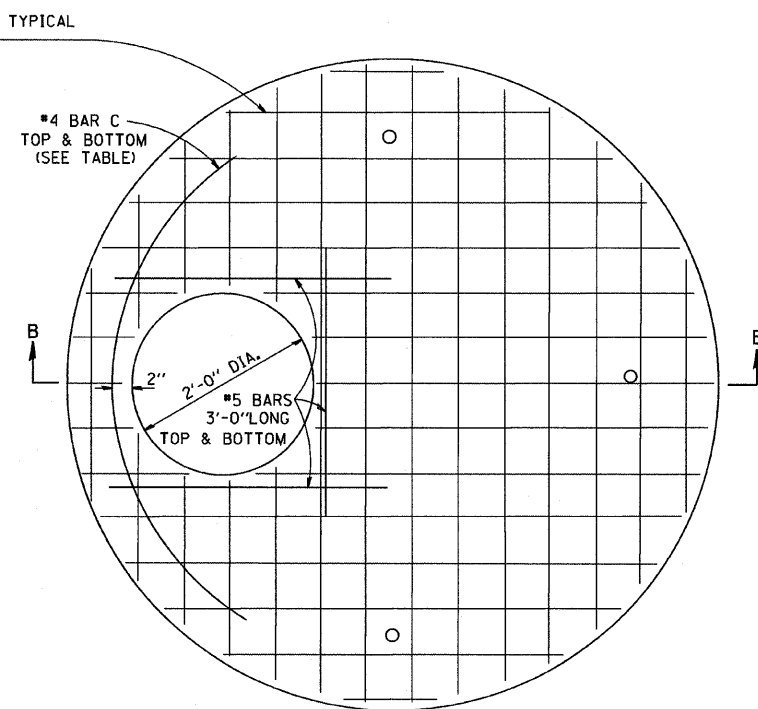

SECTION B-B

TABLE

DIAMETER OF OPENING	REINFORCEMENT OR "A" WWF EACH DIRECTION	BAR SIZE	BAR C		
			SIZE	LENGTH	RADIUS
2'-0"	1.06 SQ. IN./LIN. FT.	#6	#4	6'-0"	38"
4'-0"	0.82 SQ. IN./LIN. FT.	#6	#4	9'-0"	38"

NOTE: THIS STRUCTURE SHOULD BE USED WITH PIPES SIZE 54" DIA. OR SMALLER.

REVISIONS	
NAME	DATE
	10/18/02

ILLINOIS DEPARTMENT OF TRANSPORTATION

**MANHOLE TYPE A
7 FOOT DIAMETER**

SCALE: VERT. NONE
HORIZ.

DRAWN BY

CHECKED BY

BD600-11 (BD-37)



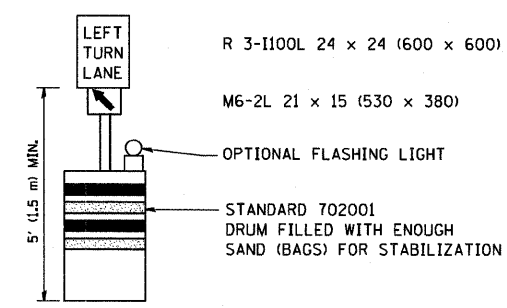
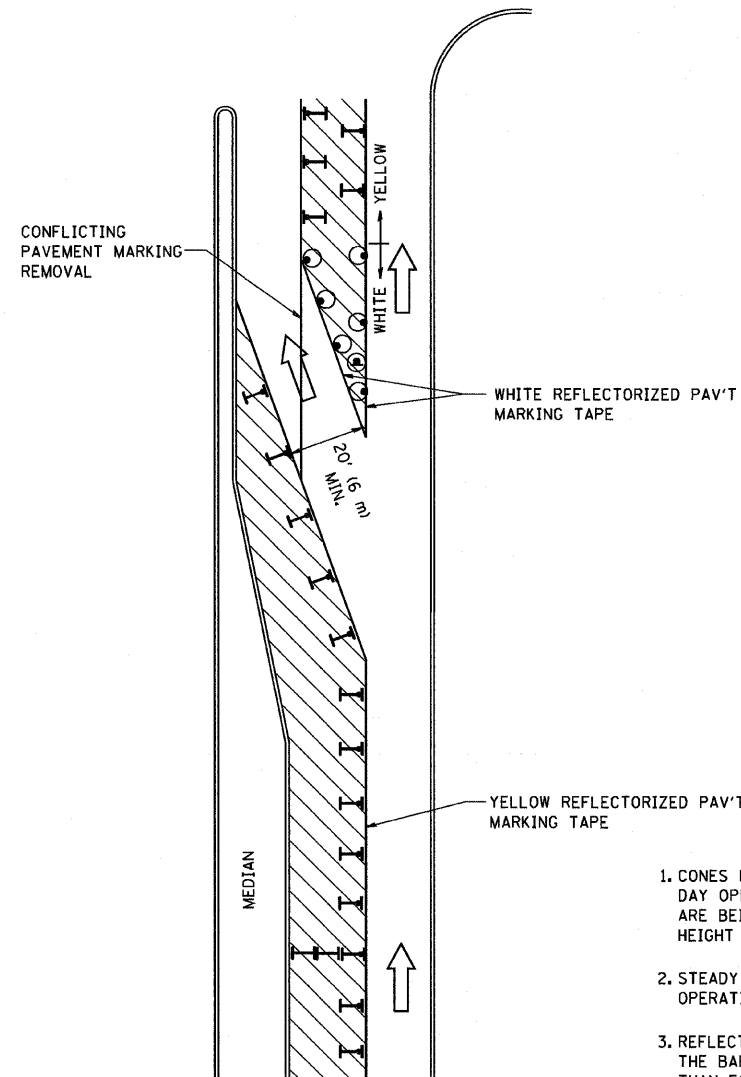

F.A.J. RTE.	SECTION	COUNTY	TOTAL SHEETS	SHEET NO.
351	3277R	COOK	541	378
STA.		TO STA.		
FED. ROAD DIST. NO.	ILLINOIS	FED. AID PROJECT		

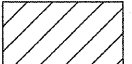
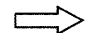

GENERAL NOTES

1. CONES MAY BE SUBSTITUTED FOR BARRICADES OR DRUMS AT HALF THE SPACING DURING DAY OPERATIONS. CONES SHALL BE A MINIMUM OF 28 (710) IN HEIGHT. WHEN CONES ARE BEING USED, THE "LEFT TURN LANE" SIGN MAY BE SKID MOUNTED AT A MINIMUM HEIGHT OF 5' (1.5 m).
2. STEADY BURNING LIGHTS WILL NOT BE REQUIRED ON BARRICADES OR DRUMS FOR DAY OPERATIONS. ALL LIGHTS SHALL BE MONODIRECTIONAL.
3. REFLECTORIZED TEMPORARY PAVEMENT MARKING TAPE SHALL BE PLACED THROUGHOUT THE BARRICADED AREA OF EACH TURN BAY WHERE THE CLOSURE TIME IS GREATER THAN FOURTEEN DAYS.
4. THIS APPLICATION ALSO APPLIES WHEN WORK IS BEING PERFORMED IN THE RIGHT LANE(S) AND THE RIGHT TURN BAY IS TO REMAIN OPEN. UNDER THIS CONDITION, "RIGHT TURN LANE" R3-100 24 x 24 (600 x 600) AND M6-2R 21 x 15 (530 x 380) SHALL BE USED.
5. THESE CONTROLS SHALL SUPPLEMENT MAINLINE TRAFFIC CONTROL FOR LANE CLOSURES.
6. LONGITUDINAL DIMENSIONS MAY BE ADJUSTED TO FIT FIELD CONDITIONS.
7. FORM BT 725 IS REQUIRED.
8. TRAFFIC CONTROL AND PROTECTION AT TURN BAYS (TO REMAIN OPEN TO TRAFFIC) SHALL BE INCLUDED IN THE COST SPECIFIED TRAFFIC CONTROL STANDARDS OR ITEMS.

LEGEND

-  WORK AREA
-  LANE OPEN TO TRAFFIC
-  TYPE I OR II BARRICADE WITH STEADY BURN LIGHT
-  DRUM WITH STEADY BURN LIGHT
-  DRUM WITH SIGN (WITH OPTIONAL FLASHING LIGHT) SEE DETAIL
-  TYPE I OR II CHECK BARRICADE WITH FLASHING LIGHT

All dimensions are in inches (millimeters) unless otherwise shown.

REVISIONS	
NAME	DATE
T. RAMMACHER	09/08/94
A. HOUSEH	11/07/95
A. HOUSEH	10/12/96
T. RAMMACHER	01/06/00

ILLINOIS DEPARTMENT OF TRANSPORTATION
**TRAFFIC CONTROL AND PROTECTION
 AT TURN BAYS
 (TO REMAIN OPEN TO TRAFFIC)**

SCALE: NONE

DRAWN BY
 CHECKED BY LHA
 TC-14

F.A.U. RTE.	SECTION	COUNTY	TOTAL SHEETS	SHEET NO.
351	3277R	COOK	541	379
STA.		TO STA.		
FED. ROAD DIST. NO.	ILLINOIS	FED. AID PROJECT		

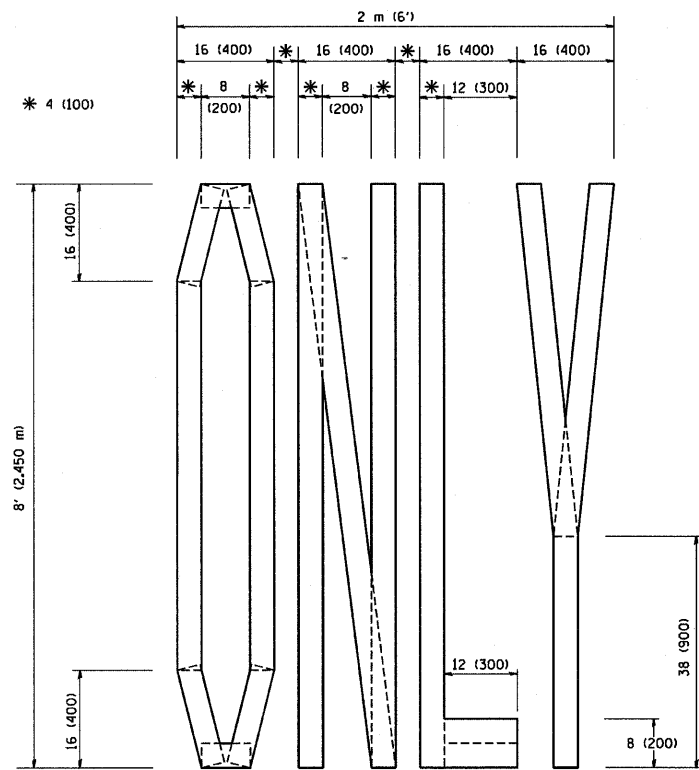

QUANTITY
 4 (100) LINE = 64.1 ft. (19.7 m)
 21.1 sq. ft. (1.97 sq. m)

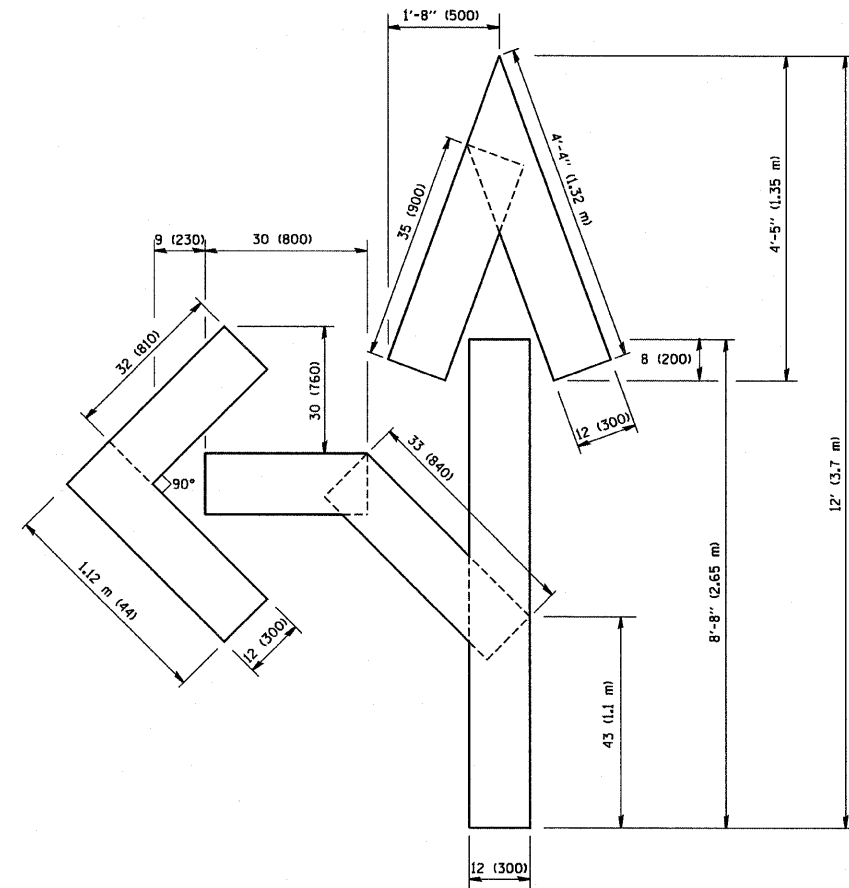

QUANTITY
 4 (100) LINE = 82.5 ft. (25.3 m)
 27.5 sq. ft. (2.53 sq. m)

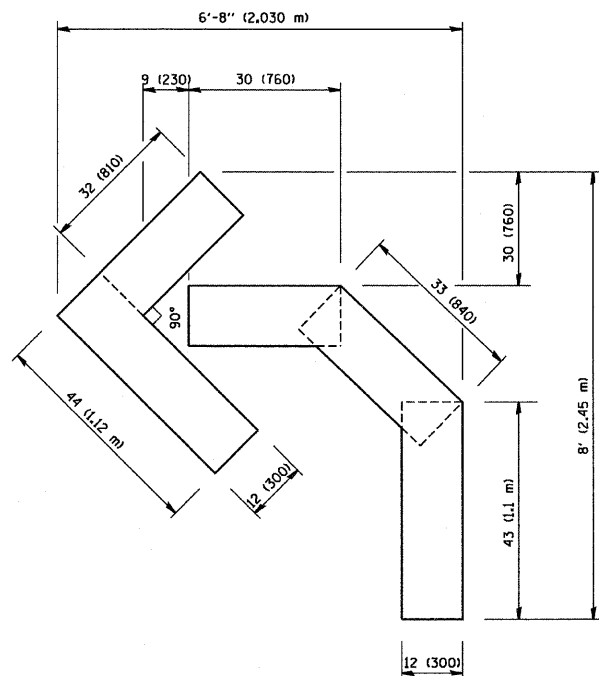

QUANTITY
 4 (100) LINE = 45.5 ft. (13.9 m)
 15.2 sq. ft. (1.39 sq. m)

All dimensions are in inches (millimeters) unless otherwise shown.

REVISIONS	
NAME	DATE
T. RAMMACHER	09/18/94
J. OBERLE	06/01/96
T. RAMMACHER	06/05/96
T. RAMMACHER	11/04/97
T. RAMMACHER	03/02/98
E. GOMEZ	08/28/00

ILLINOIS DEPARTMENT OF TRANSPORTATION

PAVEMENT MARKING
 LETTERS AND SYMBOLS
 FOR TRAFFIC STAGING

SCALE: NONE

DRAWN BY CADD
 CHECKED BY

PLOT DATE = 3/7/2007
 FILE NAME = K:\dashed\kvd6dgn
 USER NAME = sburndi

F.A.U. RTE.	SECTION	COUNTY	TOTAL SHEETS	SHEET NO.
351	3277R	COOK	541	380
STA.		TO STA.		
FED. ROAD DIST. NO.	ILLINOIS	FED. AID PROJECT		



3.0" RADIUS, 0.5" BORDER, WHITE ON GREEN; REFLECTORIZED
 "DRIVEWAY" D; "ENTRANCE" D; STANDARD ARROW CUSTOM 12.0" x 5.0"

NOTES:

1. HALF OF THE SIGNS WILL REQUIRE A LEFT HAND FACING ARROW.
2. TWO SIGNS SHALL BE USED AT EACH COMMERCIAL ENTRANCE PLACED BACK-TO-BACK: ONE WITH A RIGHT HAND ARROW (SHOWN) SHALL BE PLACED ON THE NEAR RIGHT SIDE THE DRIVEWAY AND ONE WITH A LEFT HAND ARROW SHALL BE PLACED ON THE FAR LEFT SIDE OF THE DRIVEWAY.
3. SIGNS TO BE PAID FOR AS ITEM "TEMPORARY INFORMATION SIGNING".

PLOT DATE = 3/9/2007
 FILE NAME = K:\asist\1\25.dgn
 USER NAME = bshard

REVISIONS	
NAME	DATE
C. JUCIUS	02/15/07

ILLINOIS DEPARTMENT OF TRANSPORTATION

**DRIVEWAY ENTRANCE
SIGNING**

SCALE: NONE
DATE

DRAWN BY R.H.
CHECKED BY

F.A.U. RTE.	SECTION	COUNTY	TOTAL SHEETS	SHEET NO.
351	3277R	COOK	541	381
STA.		TO STA.		
FED. ROAD DIST. NO.		ILLINOIS	FED. AID PROJECT	

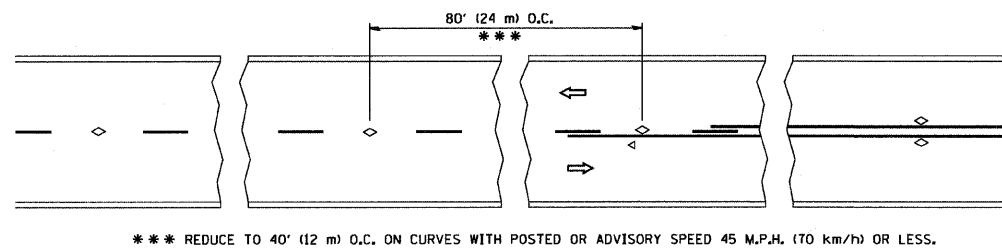

TWO-LANE/TWO-WAY

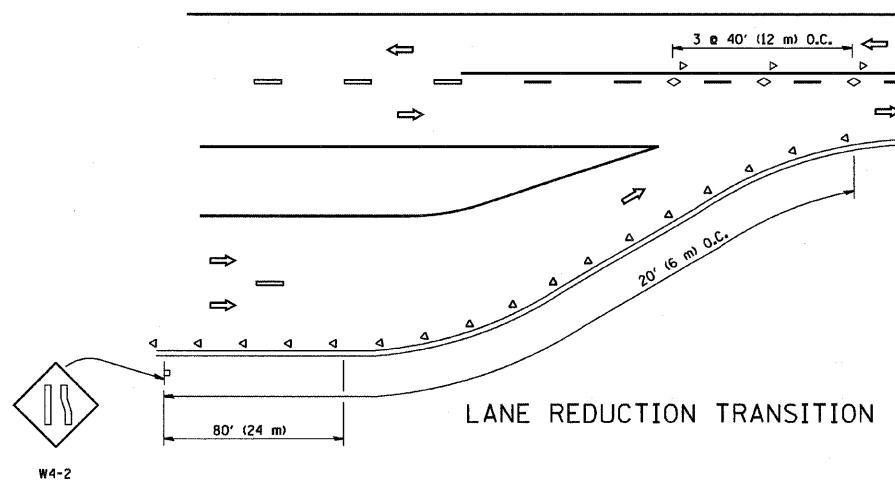

LANE REDUCTION TRANSITION

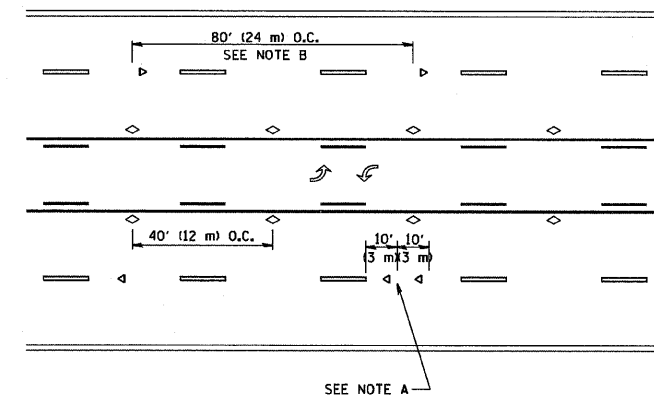

TWO-WAY LEFT TURN

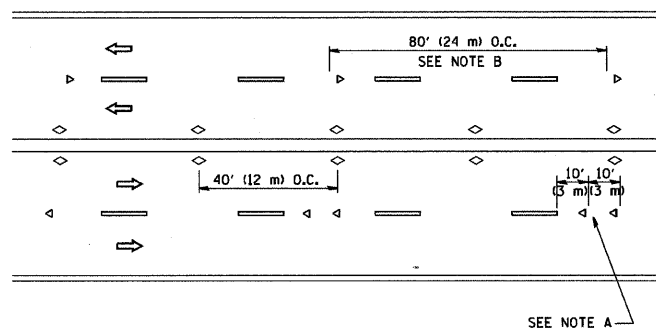

MULTI-LANE/UNDIVIDED

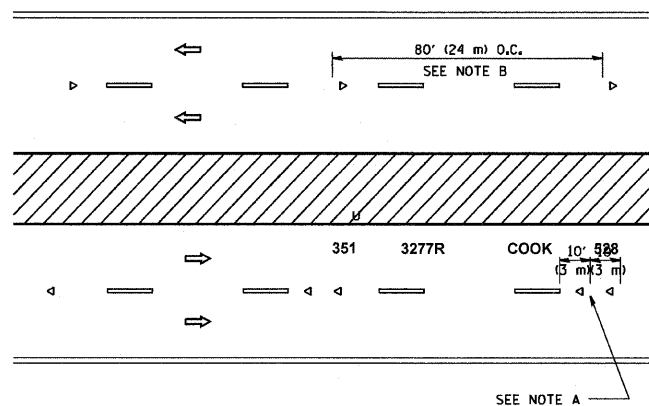

MULTI-LANE/DIVIDED

GENERAL NOTES

1. MARKERS USED WITH DASHED LINES SHALL BE CENTERED IN THE GAP BETWEEN SEGMENTS.
2. MARKERS USED ADJACENT TO SOLID LINES SHALL BE OFFSET 2 TO 3 (50 TO 75) TOWARD TRAFFIC AS SHOWN.
3. MARKERS THROUGH TANGENTS LESS THAN 500' (150 m) IN LENGTH BETWEEN CURVES SHALL BE INSTALLED AT THE LESSER OF THE TWO CURVE SPACINGS.

SYMBOLS

- YELLOW STRIPE
- WHITE STRIPE
- ◁ ONE-WAY AMBER MARKER
- ◁ ONE-WAY CRYSTAL MARKER (W/O)
- ◇ TWO-WAY AMBER MARKER

LANE MARKER NOTES

- B. REDUCE TO 40' (12 m) O.C. ON CURVES WHERE ADVISORY SPEEDS ARE 10 M.P.H (20 km/h) LOWER THAN POSTED SPEEDS.
- A. USE DOUBLE LANE LINE MARKERS SPACED AS SHOWN.

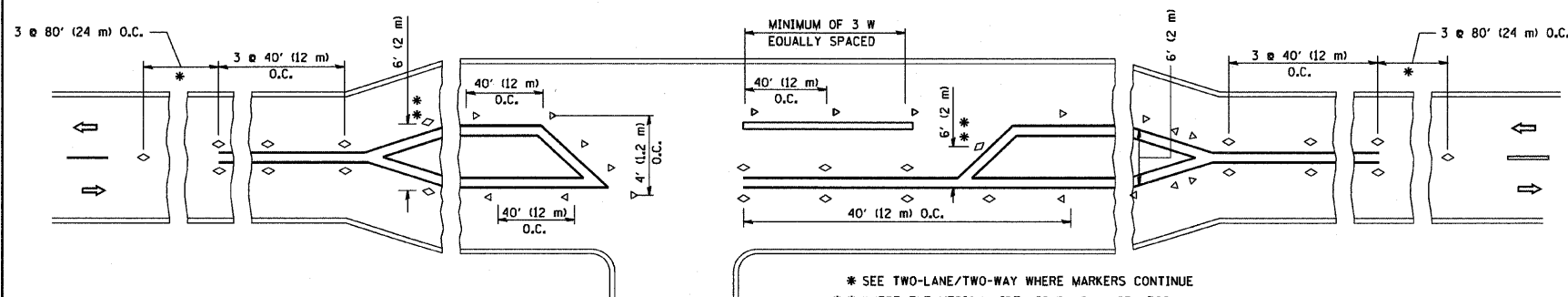

LEFT TURN

- * SEE TWO-LANE/TWO-WAY WHERE MARKERS CONTINUE
- ** WHERE THE MEDIAN WIDTH IS 6' (2 m) OR LESS USE TWO-WAY MARKERS.

All dimensions are in inches (millimeters) unless otherwise shown.

REVISIONS	
NAME	DATE
T. RAMMACHER	09-19-94
T. RAMMACHER	03-12-99
T. RAMMACHER	01-06-00

ILLINOIS DEPARTMENT OF TRANSPORTATION
 TYPICAL APPLICATIONS
 RAISED REFLECTIVE PAVEMENT
 MARKERS (SNOW-PLOW RESISTANT)

SCALE: NONE

DRAWN BY CADD
 CHECKED BY
 TC-11

F.A.U. RTE.	SECTION	COUNTY	TOTAL SHEETS	SHEET NO.
351	3277R	COOK	541	382
STA.		TO STA.		
FED. ROAD DIST. NO.		ILLINOIS FED. AID PROJECT		

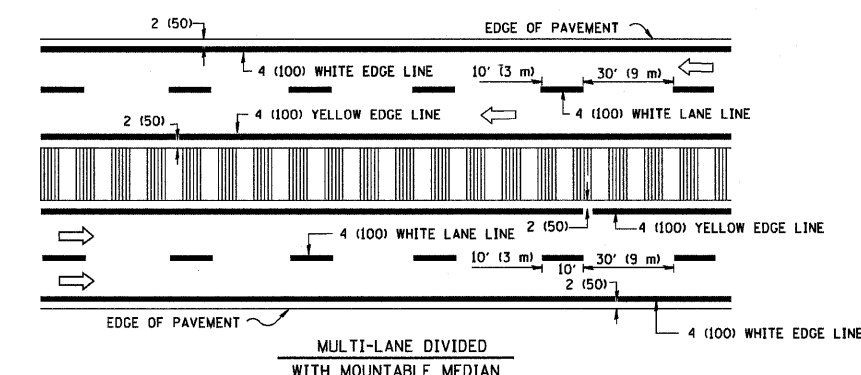
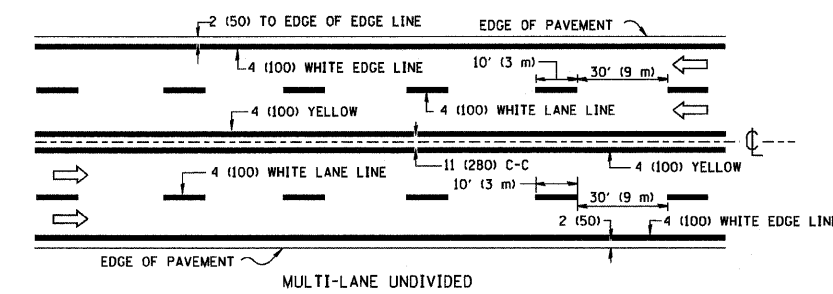
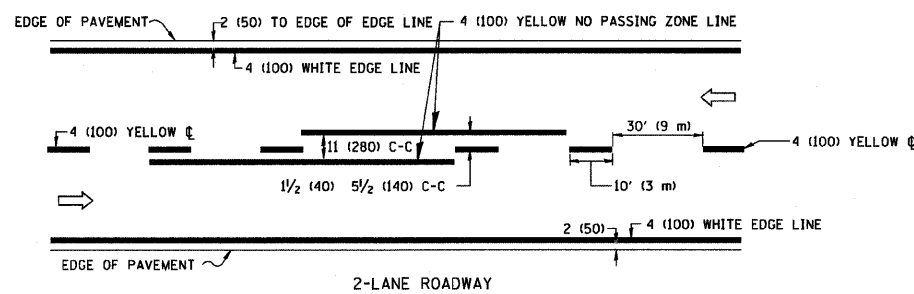

NOTE: MEDIANS WITH BARRIER CURB DO NOT REQUIRE AN EDGE LINE

TYPICAL LANE AND EDGE LINE MARKING

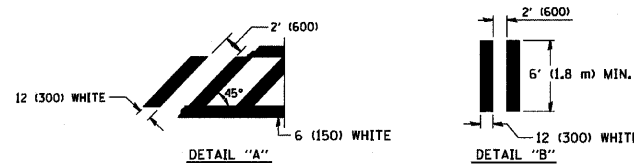
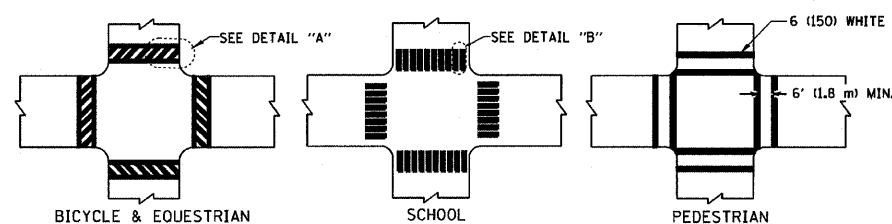

TYPICAL CROSSWALK MARKING

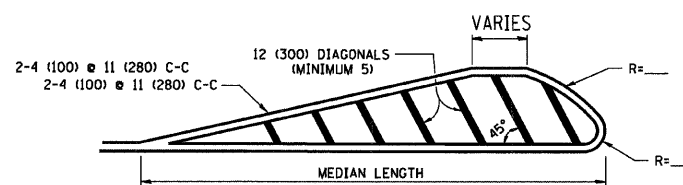
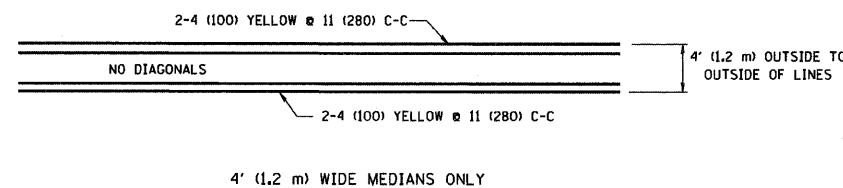

FOR MEDIAN LENGTHS WHERE DIAGONAL SPACING CANNOT BE ATTAINED, USE 5 (FIVE) EQUALLY SPACED DIAGONAL LINES.

DIAGONAL LINE SPACING: 50' (15 m) C-C (LESS THAN 30MPH (50 km/h))
75' (25 m) C-C 30MPH (50 km/h) TO 45MPH (70 km/h)
150' (45 m) C-C (MORE THAN 45MPH (70 km/h))

MEDIANS OVER 4' (1.2 m) WIDE

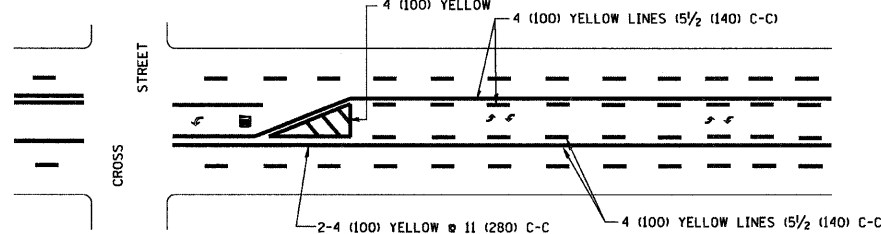

A MINIMUM OF TWO PAIRS OF TURN ARROWS SHALL BE USED, WHITE IN COLOR. ADDITIONAL PAIRS SHALL BE PLACED AT 200' (60 m) TO 300' (90 m) INTERVALS.

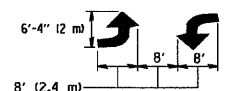

MEDIAN WITH TWO-WAY LEFT TURN LANE

TYPICAL PAINTED MEDIAN MARKING

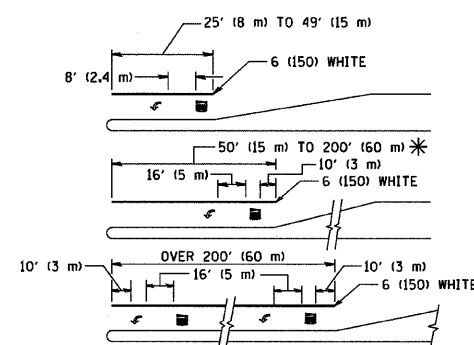

FULL SIZE LETTERS 8' (2.4 m) AND ARROWS SHALL BE USED.
AREA = 15.6 SQ. FT. (1.5 m²) ONLY AREA = 20.8 SQ. FT. (1.9 m²)

* TURN LANES IN EXCESS OF 400' (120 m) IN LENGTH MAY HAVE AN ADDITIONAL SET OF ARROW - "ONLY" INSTALLED MIDWAY BETWEEN THE OTHER TWO SETS OF ARROW - "ONLY".

TYPICAL LEFT (OR RIGHT) TURN LANE

TYPICAL TURN LANE MARKING

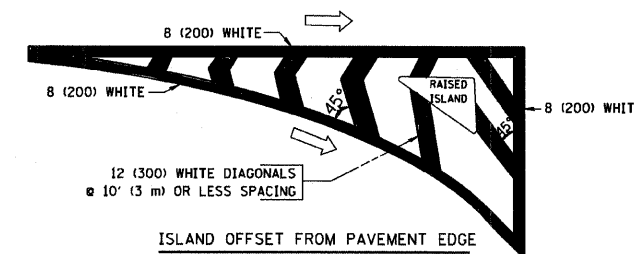

ISLAND OFFSET FROM PAVEMENT EDGE

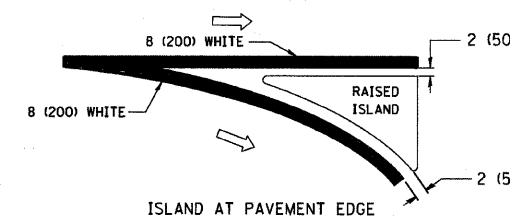

ISLAND AT PAVEMENT EDGE

TYPICAL ISLAND MARKING

TYPE OF MARKING	WIDTH OF LINE	PATTERN	COLOR	SPACING / REMARKS
CENTERLINE ON 2 LANE PAVEMENT	4 (100)	SKIP-DASH	YELLOW	10' (3 m) LINE WITH 30' (9 m) SPACE
CENTERLINE ON MULTI-LANE UNDIVIDED PAVEMENT	2 @ 4 (100)	SOLID	YELLOW	11 (280) C-C
NO PASSING ZONE LINES FOR ONE DIRECTION FOR BOTH DIRECTIONS	4 (100) 2 @ 4 (100)	SOLID SOLID	YELLOW YELLOW	5/2 (140) C-C FROM SKIP-DASH CENTERLINE 11 (280) C-C OMIT SKIP-DASH CENTERLINE BETWEEN
LANE LINES	4 (100) 5 (125) ON FREEWAYS	SKIP-DASH SKIP-DASH	WHITE WHITE	10' (3 m) LINE WITH 30' (9 m) SPACE
DOTTED LINES (EXTENSIONS OF CENTER, LANE OR TURN LANE MARKINGS)	SAME AS LINE BEING EXTENDED	SKIP-DASH	SAME AS LINE BEING EXTENDED	2' (600) LINE WITH 6' (1.8 m) SPACE
EDGE LINES	4 (100)	SOLID	YELLOW-LEFT WHITE-RIGHT	OUTLINE MOUNTABLE MEDIANS IN YELLOW; EDGE LINES ARE NOT USED NEXT TO BARRIER CURB
TURN LANE MARKINGS	6 (150) LINE; FULL SIZE LETTERS & SYMBOLS (8' (2.4m))	SOLID	WHITE	SEE TYPICAL TURN LANE MARKING DETAIL
TWO WAY LEFT TURN MARKING	2 @ 4 (100) EACH DIRECTION 8' (2.4m) LEFT ARROW	SKIP-DASH AND SOLID IN PAIRS	YELLOW WHITE	10' (3 m) LINE WITH 30' (9 m) SPACE FOR SKIP-DASH; 5/2 (140) C-C BETWEEN SOLID LINE AND SKIP-DASH LINE SEE TYPICAL TWO-WAY LEFT TURN MARKING DETAIL
CROSSWALK LINES (PEDESTRIAN) A. DIAGONALS (BIKE & EQUESTRIAN) B. LONGITUDINAL BARS (SCHOOL)	2 @ 6 (150) 12 (300) @ 45° 12 (300) @ 90°	SOLID SOLID SOLID	WHITE WHITE WHITE	NOT LESS THAN 6' (1.8 m) APART 2' (600) APART 2' (600) APART SEE TYPICAL CROSSWALK MARKING DETAILS.
STOP LINES	24 (600)	SOLID	WHITE	PLACE 4' (1.2 m) IN ADVANCE OF AND PARALLEL TO CROSSWALK, IF PRESENT. OTHERWISE, PLACE AT DESIRED STOPPING POINT, PARALLEL TO CROSSROAD CENTERLINE, WHERE POSSIBLE
PAINTED MEDIANS	2 @ 4 (100) WITH 12 (300) DIAGONALS @ 45° NO DIAGONALS USED FOR 4' (1.2 m) WIDE MEDIANS	SOLID	YELLOW; TWO WAY TRAFFIC WHITE; ONE WAY TRAFFIC	11 (280) C-C FOR THE DOUBLE LINE SEE TYPICAL PAINTED MEDIAN MARKING.
GORE MARKING AND CHANNELIZING LINES	8 (200) WITH 12 (300) DIAGONALS @ 45°	SOLID	WHITE	DIAGONALS: 15' (4.5 m) C-C (LESS THAN 30MPH (50 km/h)) 20' (6 m) C-C 30MPH (50 km/h) TO 45MPH (70 km/h) 30' (9 m) C-C (OVER 45MPH (70 km/h))
RAILROAD CROSSING	24 (600) TRANSVERSE LINES; "RR" IS 6' (1.8 m) LETTERS; 16 (400) LINE FOR "X"	SOLID	WHITE	SEE STATE STANDARD 780001 AREA OF: "R"=3.6 SQ. FT. (0.33 m ²) EACH "X"=54.0 SQ. FT. (5.0 m ²)
SHOULDER DIAGONALS	12 (300) @ 45°	SOLID	WHITE - RIGHT YELLOW - LEFT	50' (15 m) C-C (LESS THAN 30MPH (50 km/h)) 75' (25 m) C-C (30 MPH (50 km/h) TO 45MPH (70 km/h)) 150' (45 m) C-C (OVER 45MPH (70 km/h))

FOR FURTHER DETAILS ON PAVEMENT MARKING REFER TO STANDARD SPECIFICATIONS FOR ROAD AND BRIDGE CONSTRUCTION AND STATE STANDARD 780001.

All dimensions are in inches (millimeters) unless otherwise shown.

REVISIONS	
NAME	DATE
EVERS	03-19-90
T. RAMMACHER	10-27-94
ALEX HOUSEH	10-09-96
ALEX HOUSEH	10-17-96
T. RAMMACHER	01-06-00

ILLINOIS DEPARTMENT OF TRANSPORTATION

DISTRICT ONE
TYPICAL PAVEMENT
MARKINGS

SCALE: NONE

DRAWN BY CADD

CHECKED BY

TC-13

F.A.P. RTE.	SECTION	COUNTY	TOTAL SHEETS	SHEET NO.
351	3277R	COOK	541	383
STA.		TO STA.		
FED. ROAD DIST. NO.		ILLINOIS FED. AID PROJECT		
CONTRACT NO. 60774				

DATE _____
 BY _____
 SURVEYED _____
 PLOTTED _____
 NOTE BOOK _____
 AREAS CHECKED _____

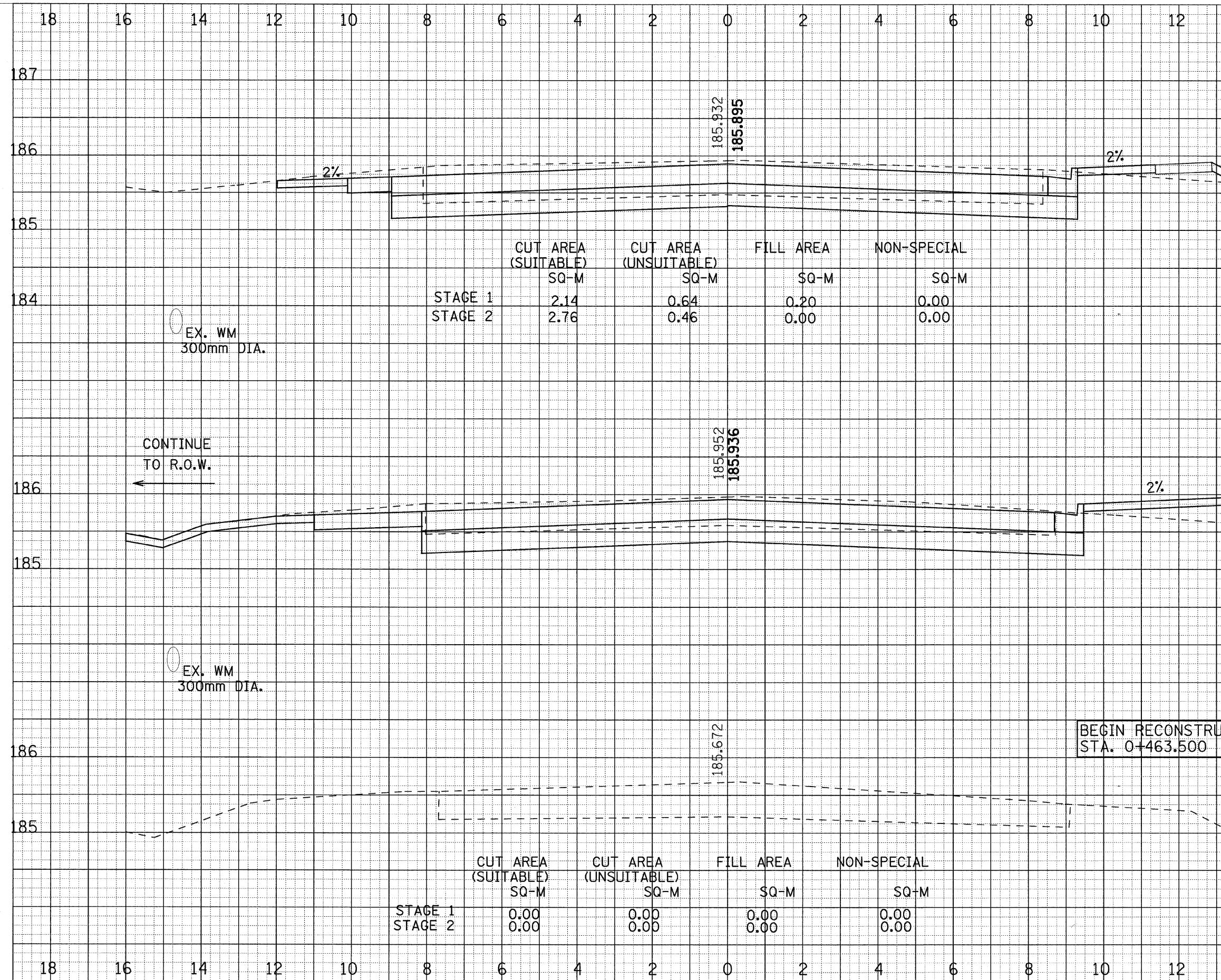

	CUT AREA (SUITABLE) SQ-M	CUT AREA (UNSUITABLE) SQ-M	FILL AREA SQ-M	NON-SPECIAL SQ-M
STAGE 1	2.14	0.64	0.20	0.00
STAGE 2	2.76	0.46	0.00	0.00

EX. WM
300mm DIA.

CONTINUE TO R.O.W.

CONTINUE TO R.O.W.

EX. WM
300mm DIA.

BEGIN RECONSTRUCTION
STA. 0+463.500

	CUT AREA (SUITABLE) SQ-M	CUT AREA (UNSUITABLE) SQ-M	FILL AREA SQ-M	NON-SPECIAL SQ-M
STAGE 1	0.00	0.00	0.00	0.00
STAGE 2	0.00	0.00	0.00	0.00

DATE _____
 BY _____
 SURVEYED _____
 PLOTTED _____
 NOTE BOOK _____
 AREAS CHECKED _____

F.A.P. RTE.	SECTION	COUNTY	TOTAL SHEETS	SHEET NO.
351	3277R	COOK	541	384
STA.		TO STA.		
FED. ROAD DIST. NO.		ILLINOIS	FED. AID PROJECT	
		CONTRACT NO. 60774		

FINAL SURVEY
 SURVEY PLOTTED
 NOTE BOOK NO. _____
 AREAS CHECKED

ORIGINAL SURVEY
 SURVEY PLOTTED
 NOTE BOOK NO. _____
 AREAS CHECKED

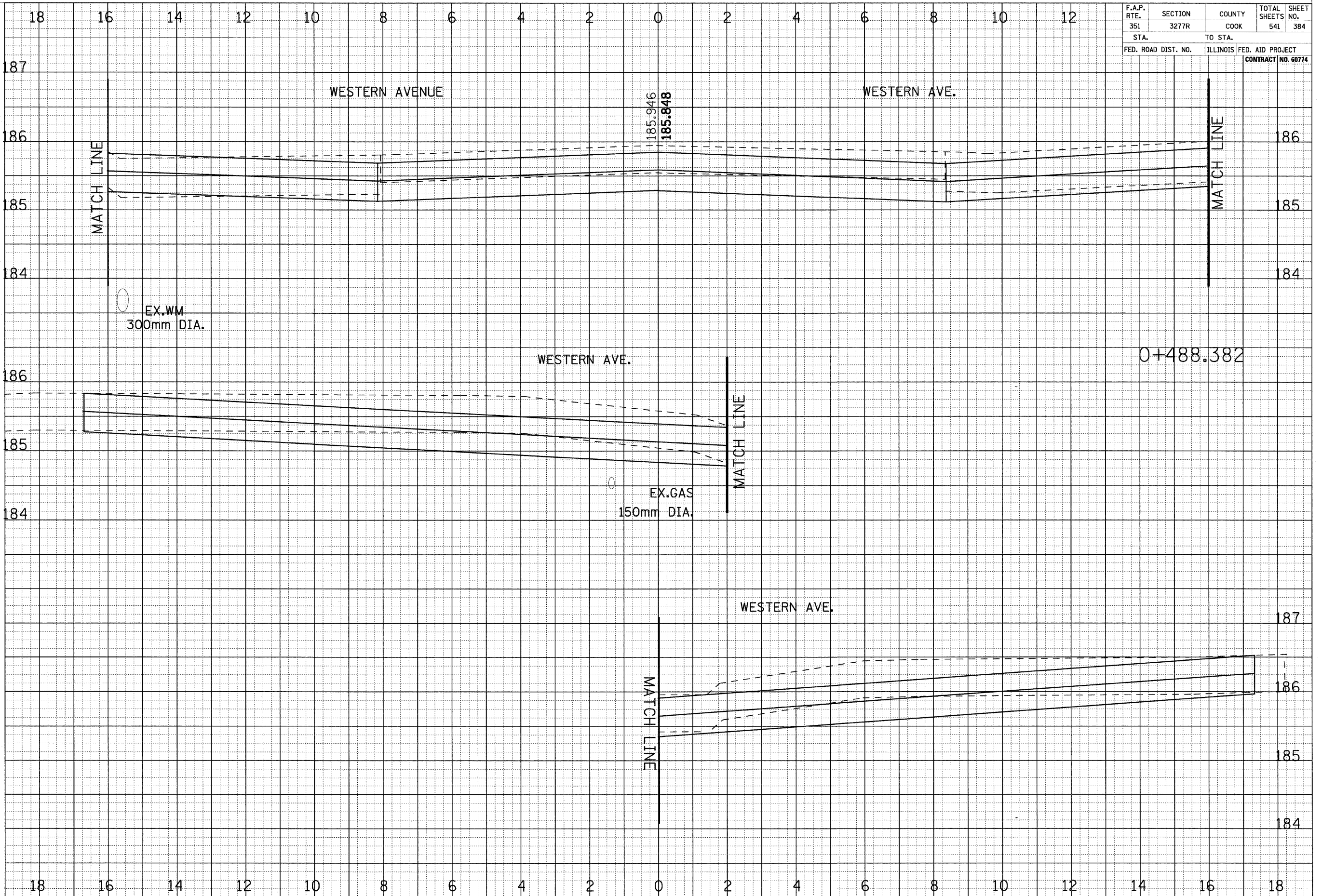

CROSS SECTIONS - US ROUTE 6

F.A.P. RTE.	SECTION	COUNTY	TOTAL SHEETS	SHEET NO.
351	3277R	COOK	541	385
STA.		TO STA.		
FED. ROAD DIST. NO.		ILLINOIS FED. AID PROJECT		
CONTRACT NO. 60774				

DATE _____ BY _____

FINAL SURVEYED SURVEY PLOTTED SURVEY PLOTTED SURVEY PLOTTED SURVEY PLOTTED SURVEY PLOTTED

NOTE BOOK NO. _____ AREAS CHECKED _____

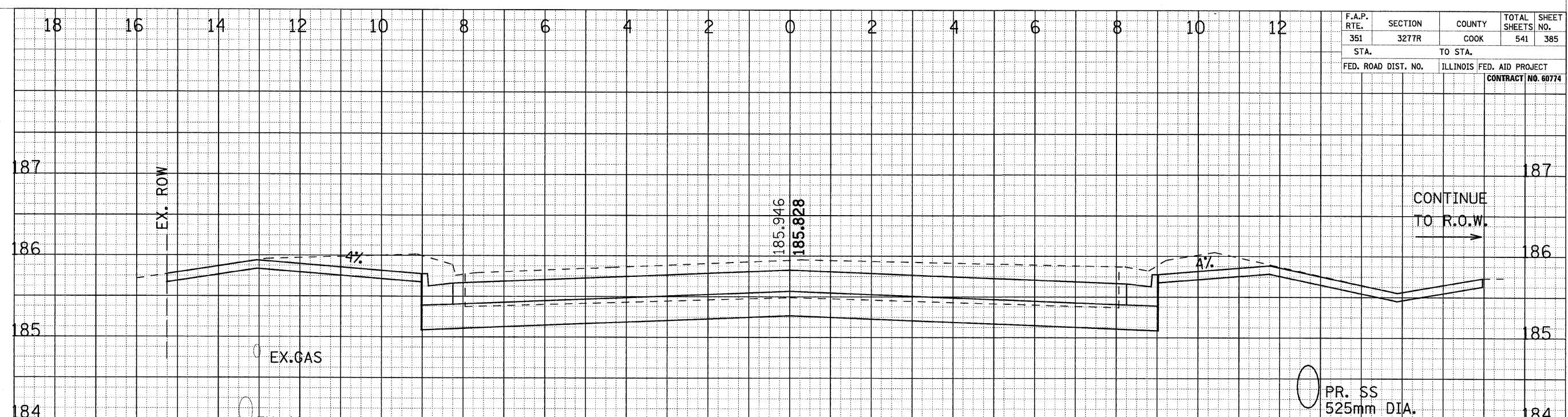

	CUT AREA (SUITABLE) SQ-M	CUT AREA (UNSUITABLE) SQ-M	FILL AREA SQ-M	NON-SPECIAL SQ-M
STAGE 1	3.59	0.78	0.00	0.00
STAGE 2	3.15	0.38	0.00	0.00

0+525.000

DATE _____ BY _____

ORIGINAL SURVEYED SURVEY PLOTTED SURVEY PLOTTED SURVEY PLOTTED SURVEY PLOTTED

NOTE BOOK NO. _____ AREAS CHECKED _____

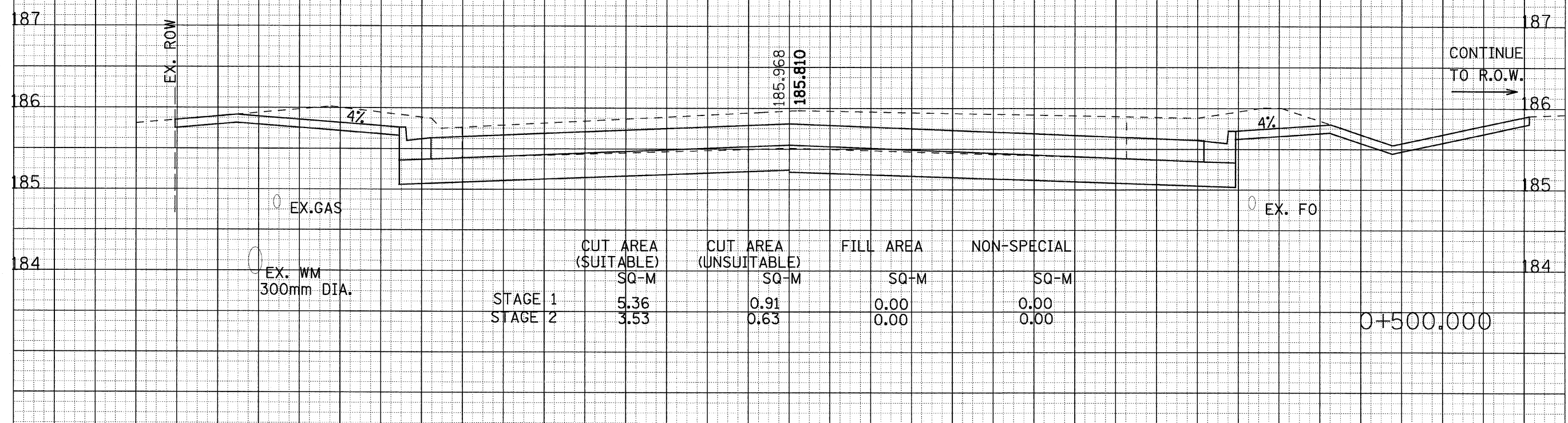

	CUT AREA (SUITABLE) SQ-M	CUT AREA (UNSUITABLE) SQ-M	FILL AREA SQ-M	NON-SPECIAL SQ-M
STAGE 1	5.36	0.91	0.00	0.00
STAGE 2	3.53	0.63	0.00	0.00

0+500.000

F.A.P. RTE. 351	SECTION 3277R	COUNTY COOK	TOTAL SHEETS 541	SHEET NO. 386
STA.		TO STA.		
FED. ROAD DIST. NO.		ILLINOIS FED. AID PROJECT		
CONTRACT NO. 60774				

DATE	BY
SURVEYED	PLOTTED
NOTE BOOK	AREAS CHECKED
NO.	

DATE	BY
SURVEYED	PLOTTED
NOTE BOOK	AREAS CHECKED
NO.	

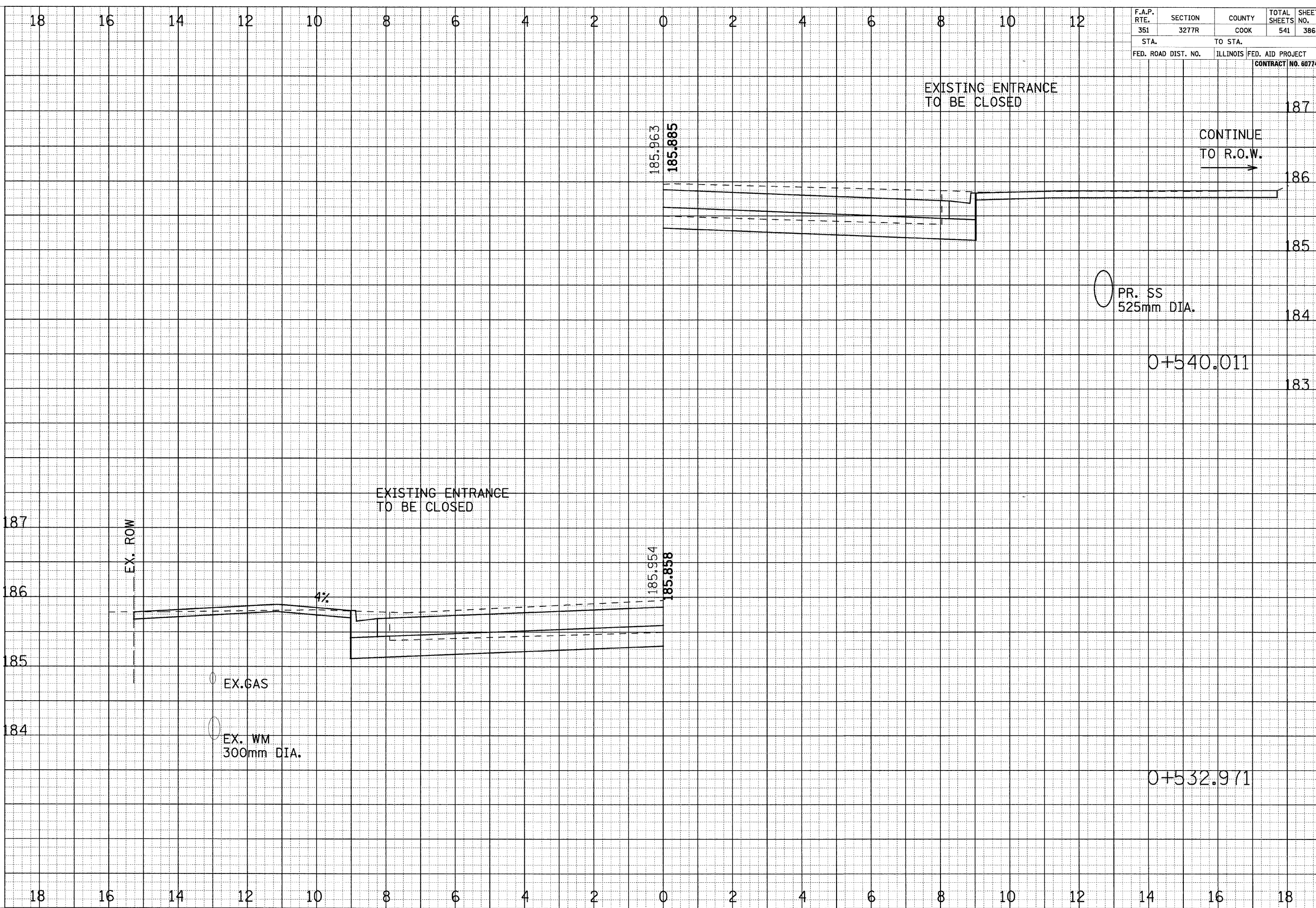

CROSS SECTIONS - US ROUTE 6

F.A.P. RTE. 351	SECTION 3277R	COUNTY COOK	TOTAL SHEETS 541	SHEET NO. 387
STA. FED. ROAD DIST. NO.		TO STA. ILLINOIS FED. AID PROJECT CONTRACT NO. 60774		

FINAL SURVEY	SURVEYED	DATE
NOTE BOOK NO.	PLOTTED	BY
	TEMP. AREAS CHECKED	

ORIGINAL SURVEY	SURVEYED	DATE
NOTE BOOK NO.	PLOTTED	BY
	TEMP. AREAS CHECKED	

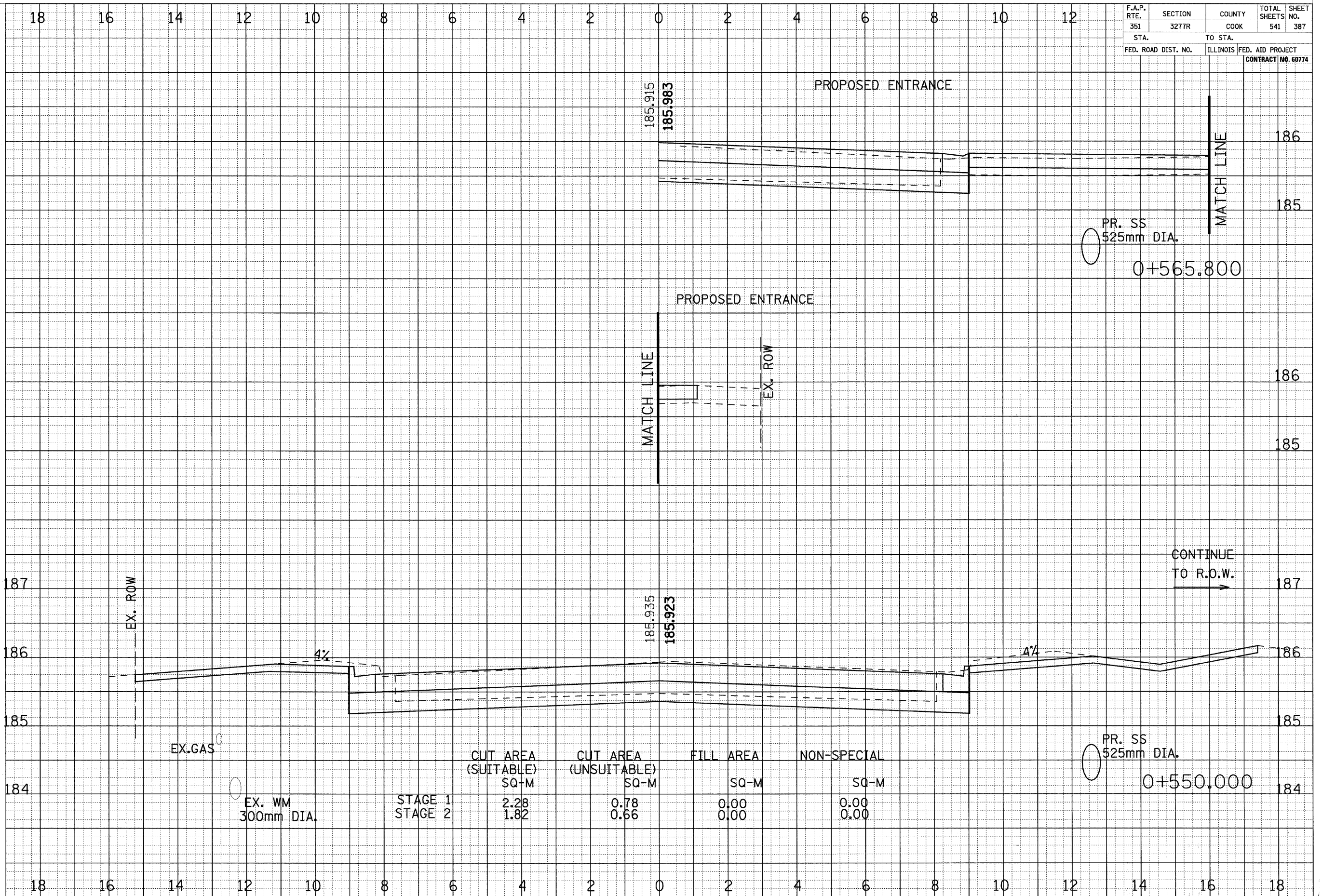

	CUT AREA (SUITABLE) SQ-M	CUT AREA (UNSUITABLE) SQ-M	FILL AREA SQ-M	NON-SPECIAL SQ-M
STAGE 1	2.28	0.78	0.00	0.00
STAGE 2	1.82	0.66	0.00	0.00

CROSS SECTIONS - US ROUTE 6

F.A.P. RTE. 351	SECTION 3277R	COUNTY COOK	TOTAL SHEETS 541	SHEET NO. 388
STA.		TO STA.		
FED. ROAD DIST. NO.		ILLINOIS FED. AID PROJECT		
CONTRACT NO. 60774				

DATE _____ BY _____

FINAL SURVEY SURVEYED PLOTTED
NOTE BOOK IS DATE AREAS CHECKED

DATE _____ BY _____

ORIGINAL SURVEY SURVEYED PLOTTED
NOTE BOOK IS DATE AREAS CHECKED

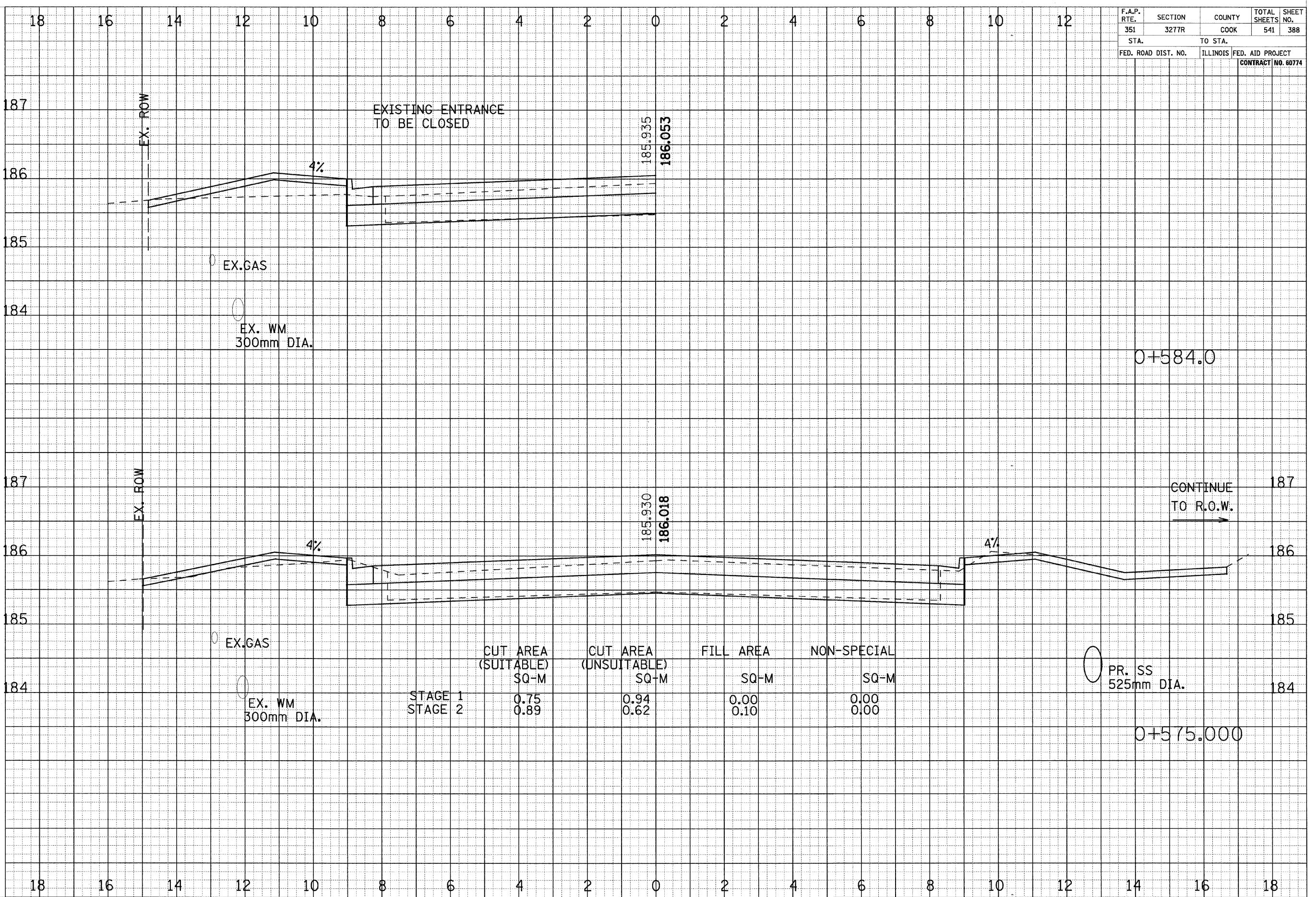

	CUT AREA (SUITABLE) SQ-M	CUT AREA (UNSUITABLE) SQ-M	FILL AREA SQ-M	NON-SPECIAL SQ-M
STAGE 1	0.75	0.94	0.00	0.00
STAGE 2	0.89	0.62	0.10	0.00

CROSS SECTIONS - US ROUTE 6

F.A.P. RTE. 351	SECTION 3277R	COUNTY COOK	TOTAL SHEETS 541	SHEET NO. 389
STA.		TO STA.		
FED. ROAD DIST. NO.		ILLINOIS FED. AID PROJECT		
CONTRACT NO. 60774				

FINAL SURVEY	SURVEYED	DATE
NOTE BOOK NO.	PLOTTED	BY
AREAS CHECKED	DATE	

ORIGINAL SURVEY	SURVEYED	DATE
NOTE BOOK NO.	PLOTTED	BY
AREAS CHECKED	DATE	

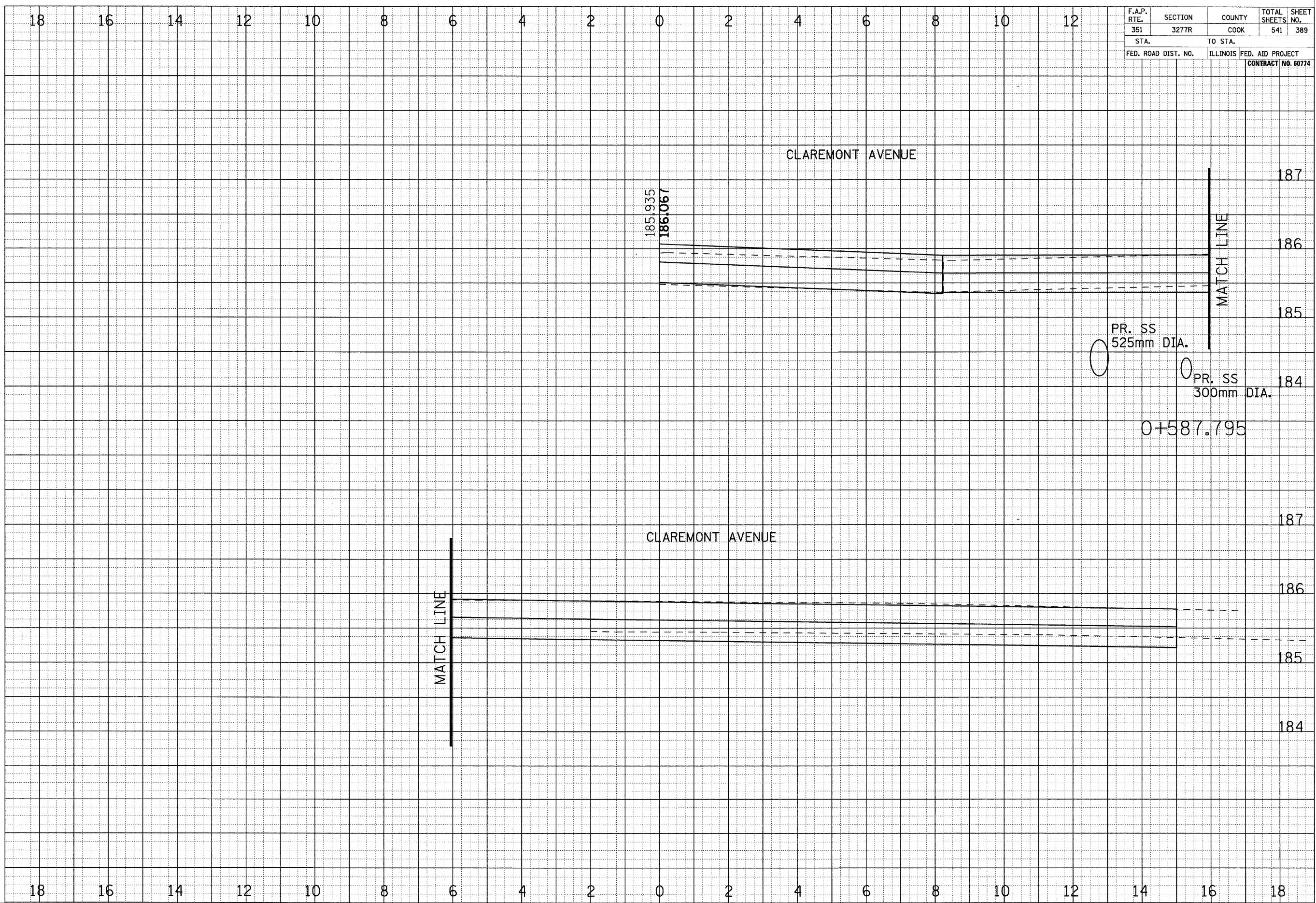

CROSS SECTIONS - US ROUTE 6

F.A.P. RTE. 351	SECTION 3277R	COUNTY COOK	TOTAL SHEETS 541	SHEET NO. 390
STA.		TO STA.		
FED. ROAD DIST. NO.		ILLINOIS FED. AID PROJECT		
CONTRACT NO. 60774				

DATE _____ BY _____

FINAL SURVEY SURVEYED PLOTTED
NOTE BOOK TEMPLATE
NO. _____ AREAS CHECKED _____

DATE _____ BY _____

ORIGINAL SURVEY SURVEYED PLOTTED
NOTE BOOK TEMPLATE
NO. _____ AREAS CHECKED _____

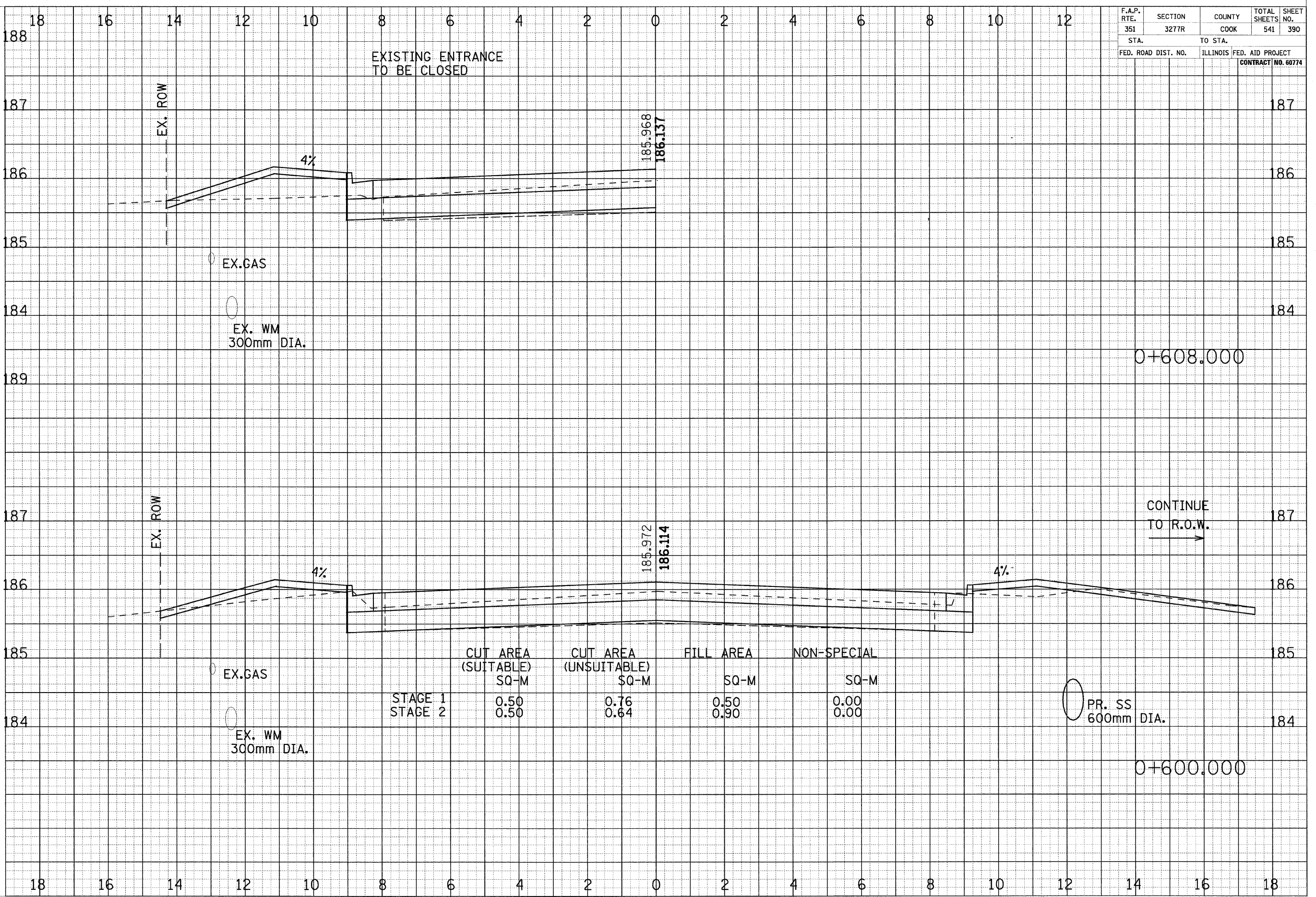

CROSS SECTIONS - US ROUTE 6

F.A.P. RTE. 351	SECTION 3277R	COUNTY COOK	TOTAL SHEETS 541	SHEET NO. 391
STA. FED. ROAD DIST. NO.		TO STA. ILLINOIS FED. AID PROJECT CONTRACT NO. 60774		

FINAL SURVEY
NO. _____

DATE _____ BY _____

SURVEYED PLOTTED
NOTE BOOK TEMPLATE AREAS CHECKED

ORIGINAL SURVEY
NO. _____

DATE _____ BY _____

SURVEYED PLOTTED
NOTE BOOK TEMPLATE AREAS CHECKED

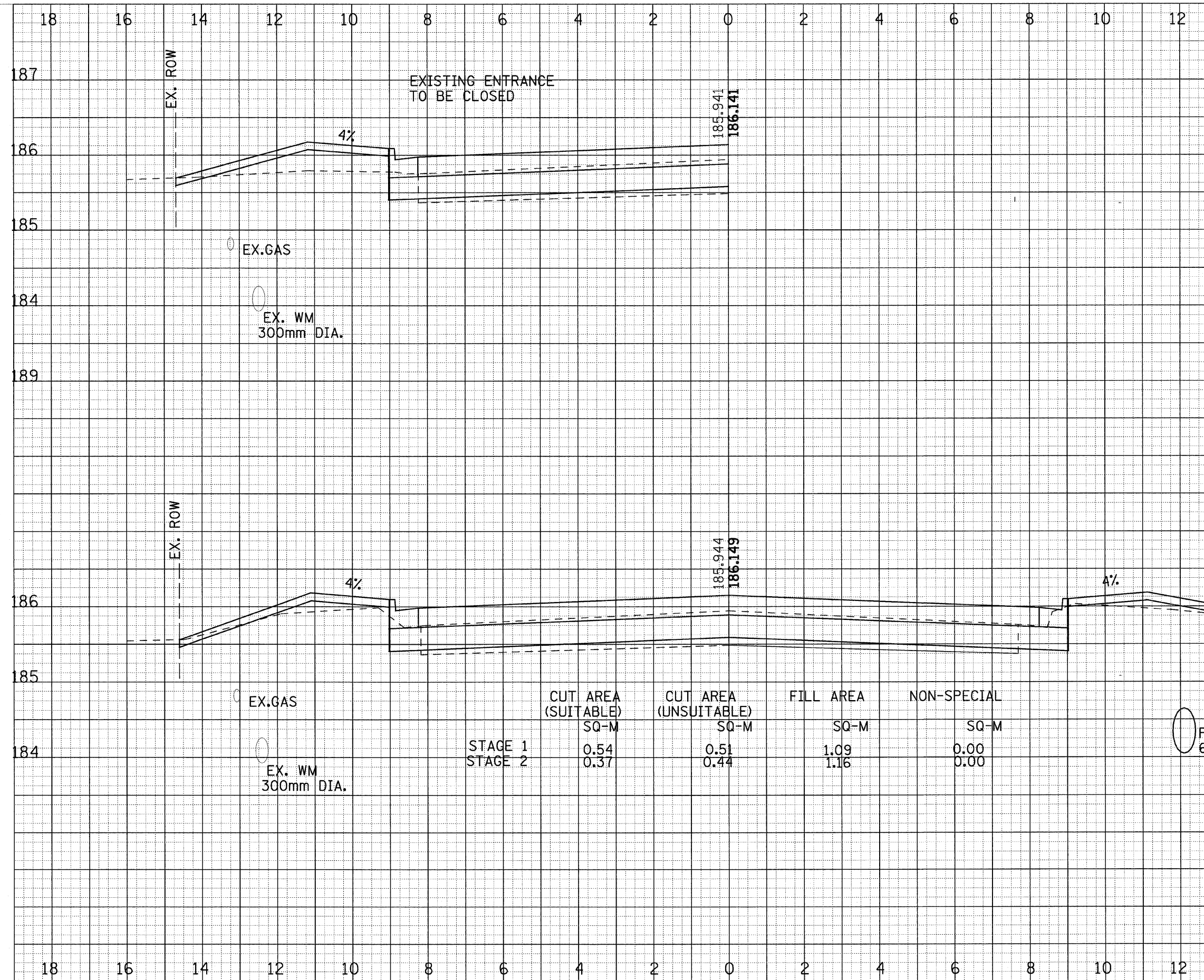

	CUT AREA (SUITABLE) SQ-M	CUT AREA (UNSUITABLE) SQ-M	FILL AREA SQ-M	NON-SPECIAL SQ-M
STAGE 1	0.54	0.51	1.09	0.00
STAGE 2	0.37	0.44	1.16	0.00

CROSS SECTIONS - US ROUTE 6

F.A.P. RTE. 351	SECTION 3277R	COUNTY COOK	TOTAL SHEETS 541	SHEET NO. 392
STA.		TO STA.		
FED. ROAD DIST. NO.		ILLINOIS FED. AID PROJECT		
CONTRACT NO. 60774				

DATE _____ BY _____
 SURVEYED _____ PLOTTED _____
 NOTE BOOK _____ REVISION _____
 NO. _____ AREAS CHECKED _____

DATE _____ BY _____
 SURVEYED _____ PLOTTED _____
 NOTE BOOK _____ REVISION _____
 NO. _____ AREAS CHECKED _____

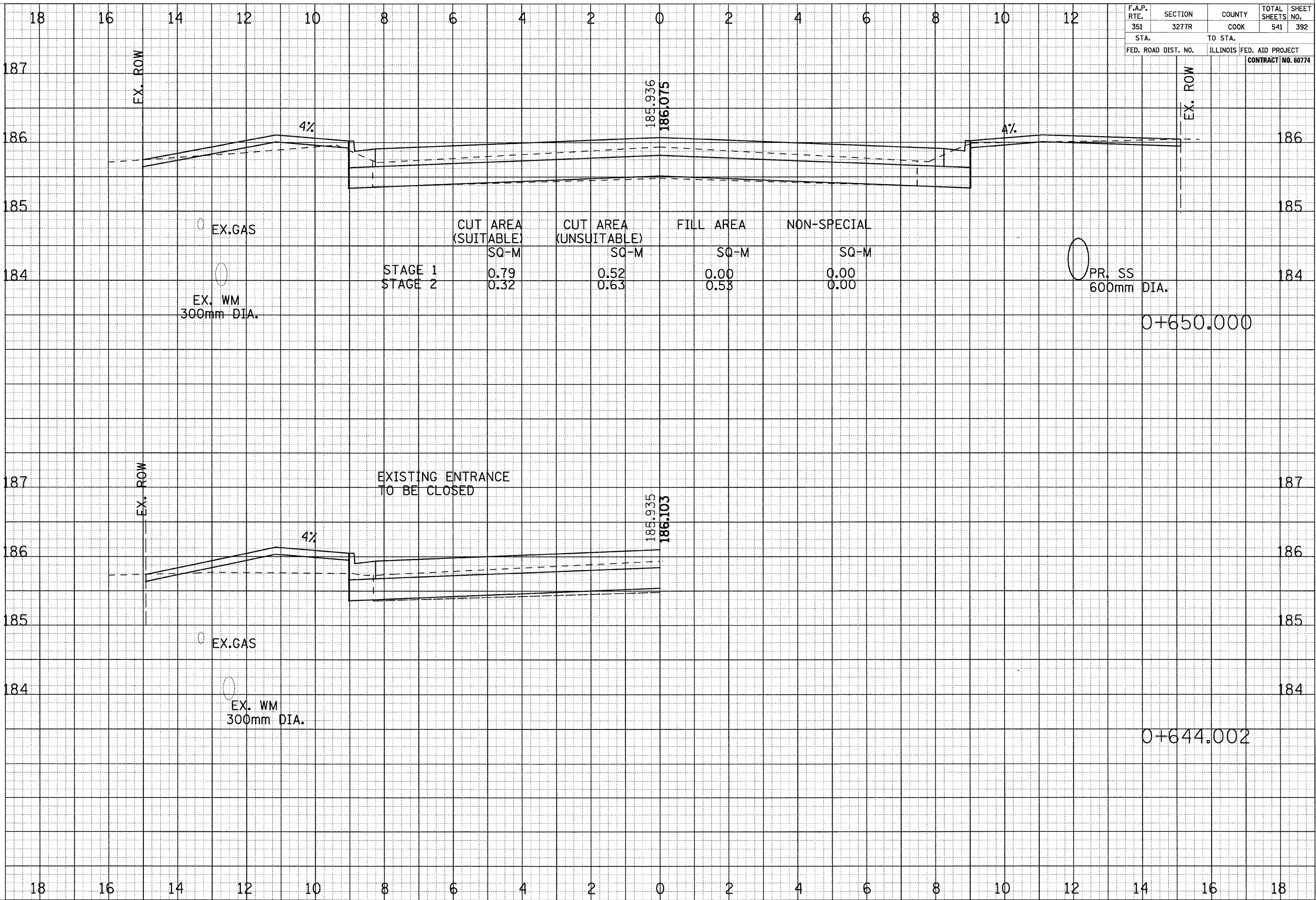

CROSS SECTIONS - US ROUTE 6

F.A.P. RTE. 351	SECTION 3277R	COUNTY COOK	TOTAL SHEETS 541	SHEET NO. 393
STA.		TO STA.		
FED. ROAD DIST. NO.		ILLINOIS	FED. AID PROJECT	
CONTRACT NO. 60774				

DATE	BY
ORIGINAL SURVEY NO.	SURVEYED
NOTE BOOK NO.	PLOTTED
	REPLATE
	AREAS CHECKED

DATE	BY
ORIGINAL SURVEY NO.	SURVEYED
NOTE BOOK NO.	PLOTTED
	REPLATE
	AREAS CHECKED

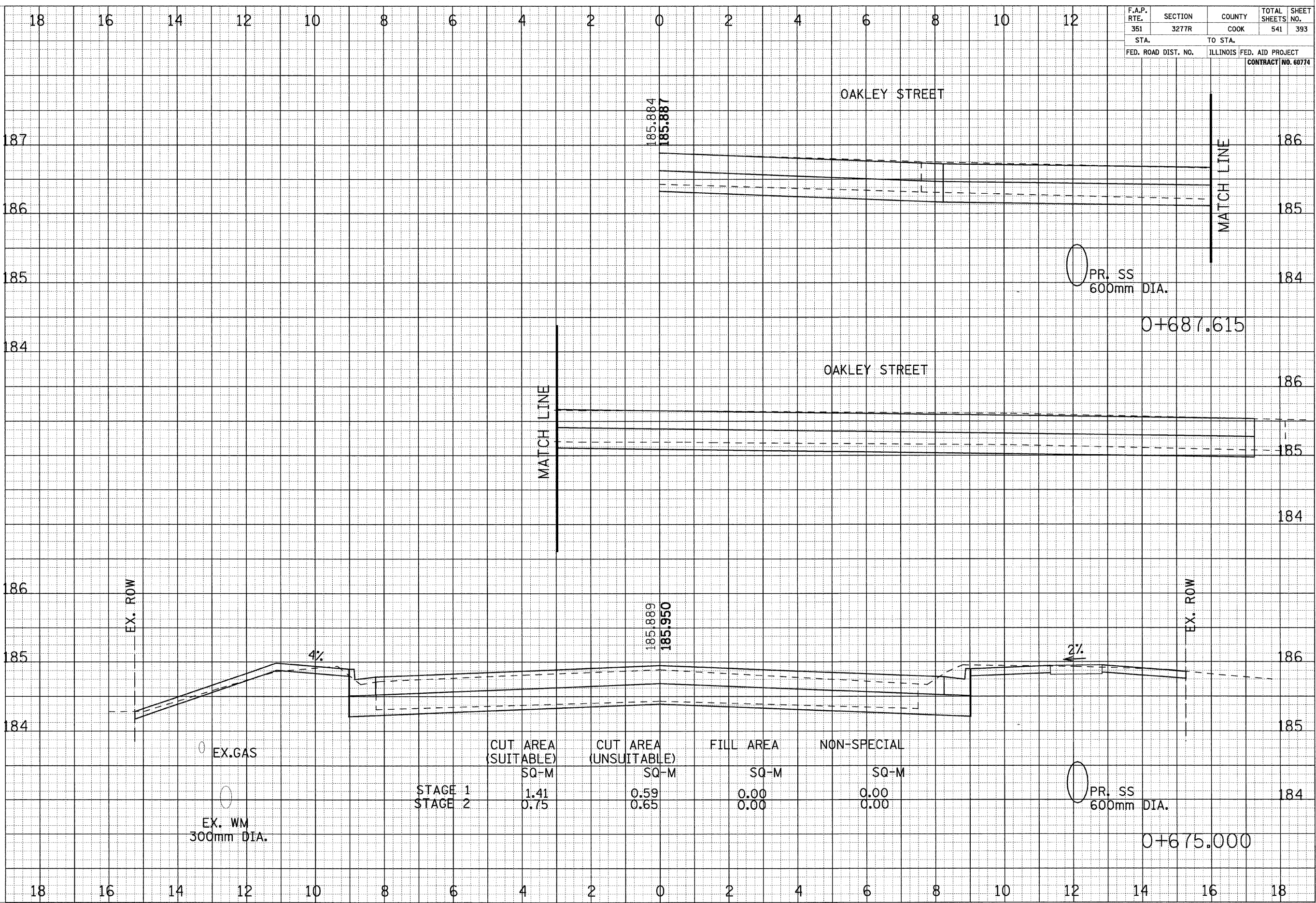

	CUT AREA (SUITABLE) SQ-M	CUT AREA (UNSUITABLE) SQ-M	FILL AREA SQ-M	NON-SPECIAL SQ-M
STAGE 1	1.41	0.59	0.00	0.00
STAGE 2	0.75	0.65	0.00	0.00

CROSS SECTIONS - US ROUTE 6

F.A.P. RTE.	SECTION	COUNTY	TOTAL SHEETS	SHEET NO.
351	3277R	COOK	541	394
STA.		TO STA.		
FED. ROAD DIST. NO.		ILLINOIS	FED. AID PROJECT	
CONTRACT NO. 60774				

DATE _____
 BY _____
 SURVEYED _____
 PLOTTED _____
 NOTE BOOK _____
 AREAS CHECKED _____

DATE _____
 BY _____
 SURVEYED _____
 PLOTTED _____
 NOTE BOOK _____
 AREAS CHECKED _____

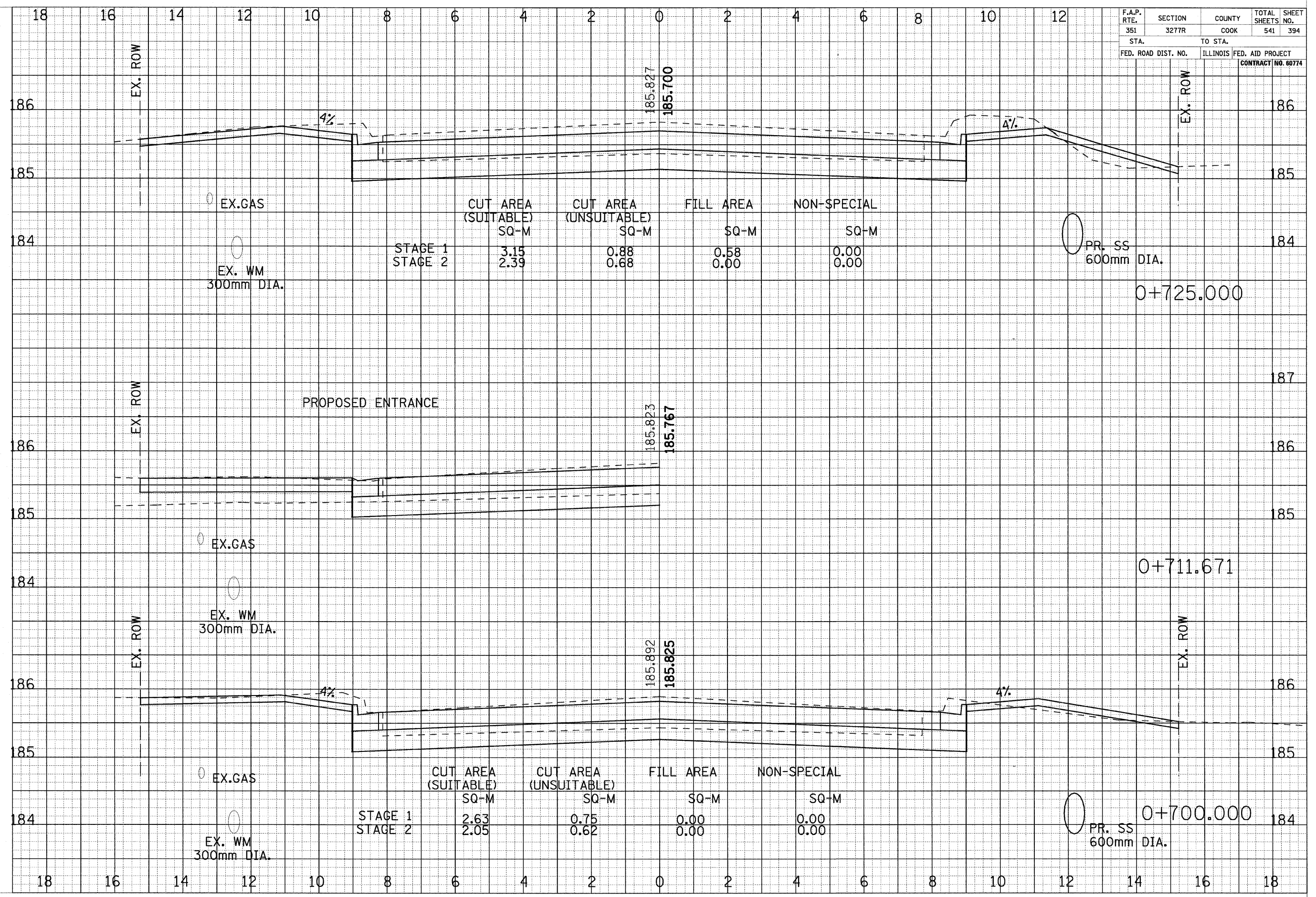

CROSS SECTIONS - US ROUTE 6

F.A.P. RTE.	SECTION	COUNTY	TOTAL SHEETS	SHEET NO.
351	3277R	COOK	541	395
STA.		TO STA.		
FED. ROAD DIST. NO.		ILLINOIS FED. AID PROJECT		
CONTRACT NO. 60774				

FINAL SURVEY PLOTTED
 SURVEY PLOTTED
 NOTE BOOK NO.
 AREAS CHECKED

ORIGINAL SURVEY PLOTTED
 SURVEY PLOTTED
 NOTE BOOK NO.
 AREAS CHECKED

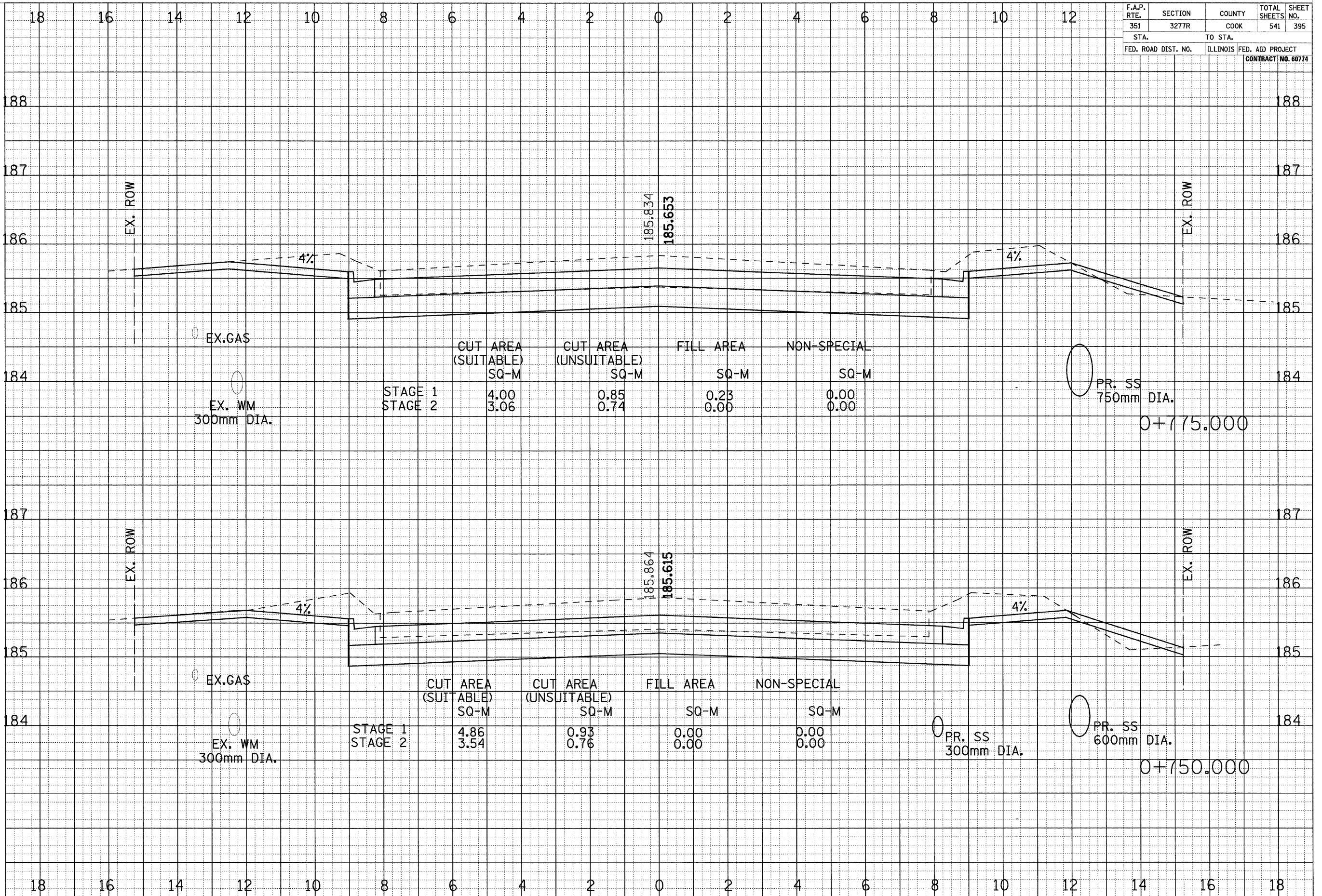

CROSS SECTIONS - US ROUTE 6

FINAL SURVEY	SURVEYED	DATE
NOTE BOOK NO.	PLOTTED	BY
AREAS CHECKED	DATE	

ORIGINAL SURVEY	SURVEYED	DATE
NOTE BOOK NO.	PLOTTED	BY
AREAS CHECKED	DATE	

F.A.P. RTE.	SECTION	COUNTY	TOTAL SHEETS	SHEET NO.
351	3277R	COOK	541	396
STA.	TO STA.			
FED. ROAD DIST. NO.	ILLINOIS FED. AID PROJECT			
CONTRACT NO. 60774				

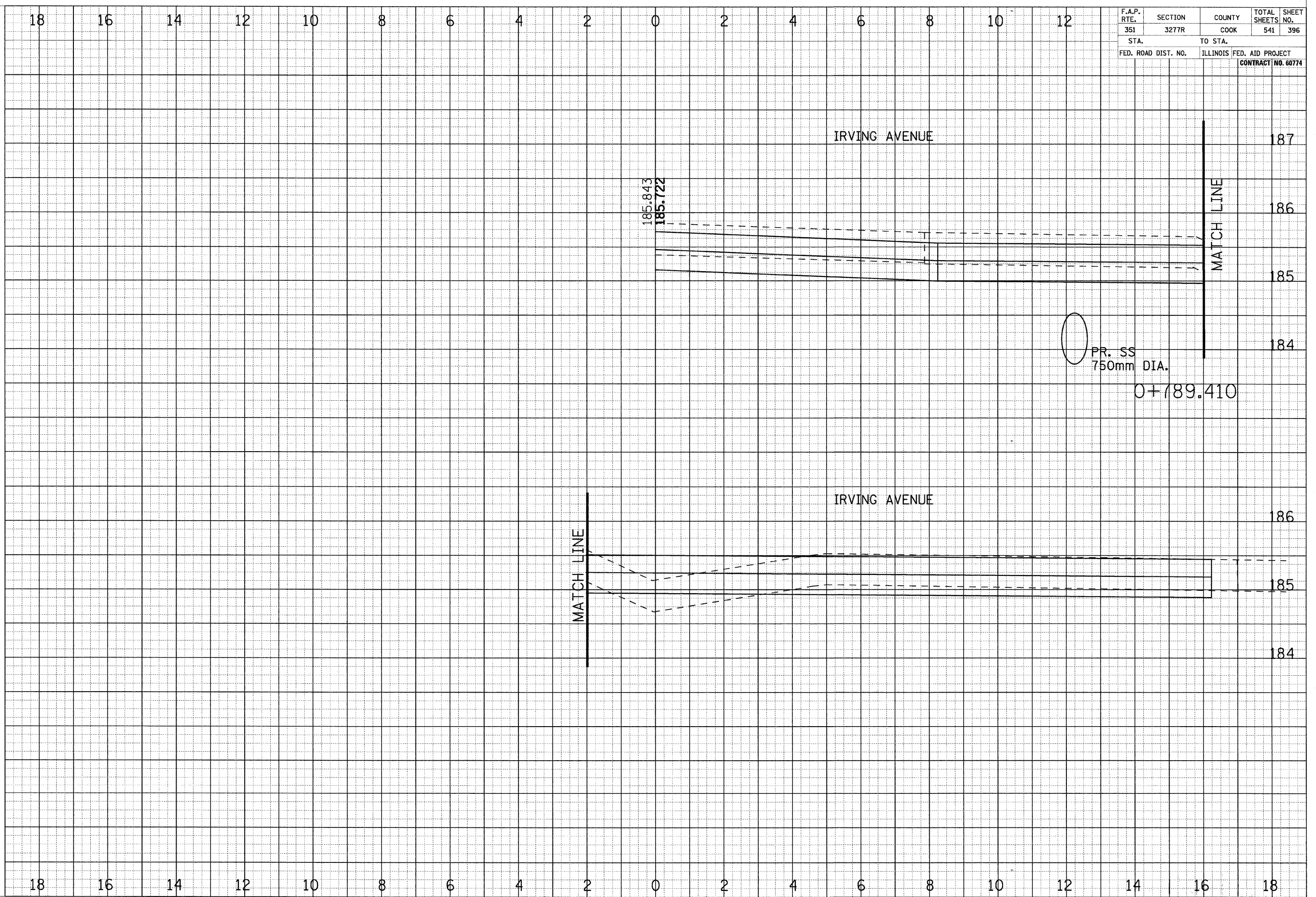

CROSS SECTIONS - US ROUTE 6

DATE _____ BY _____
 SURVEYED _____ PLOTTED _____
 SURVEY _____ PLOTTED _____
 NOTE BOOK _____
 AREAS CHECKED _____

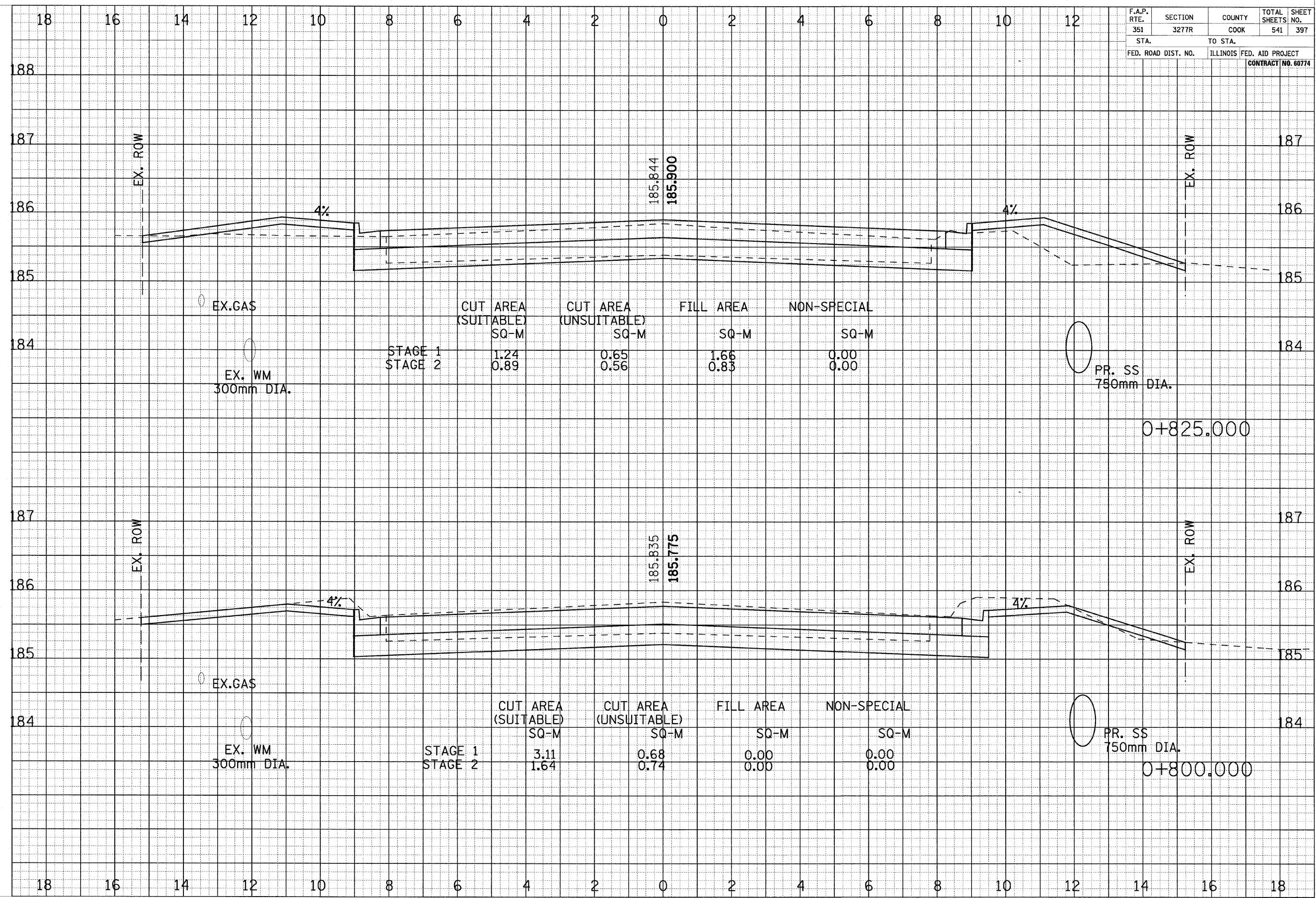

DATE _____ BY _____
 SURVEYED _____ PLOTTED _____
 SURVEY _____ PLOTTED _____
 NOTE BOOK _____
 AREAS CHECKED _____

DATE _____ BY _____
 SURVEYED _____
 PLOTTED _____
 NOTE BOOK _____
 AREAS CHECKED _____

DATE _____ BY _____
 SURVEYED _____
 PLOTTED _____
 NOTE BOOK _____
 AREAS CHECKED _____

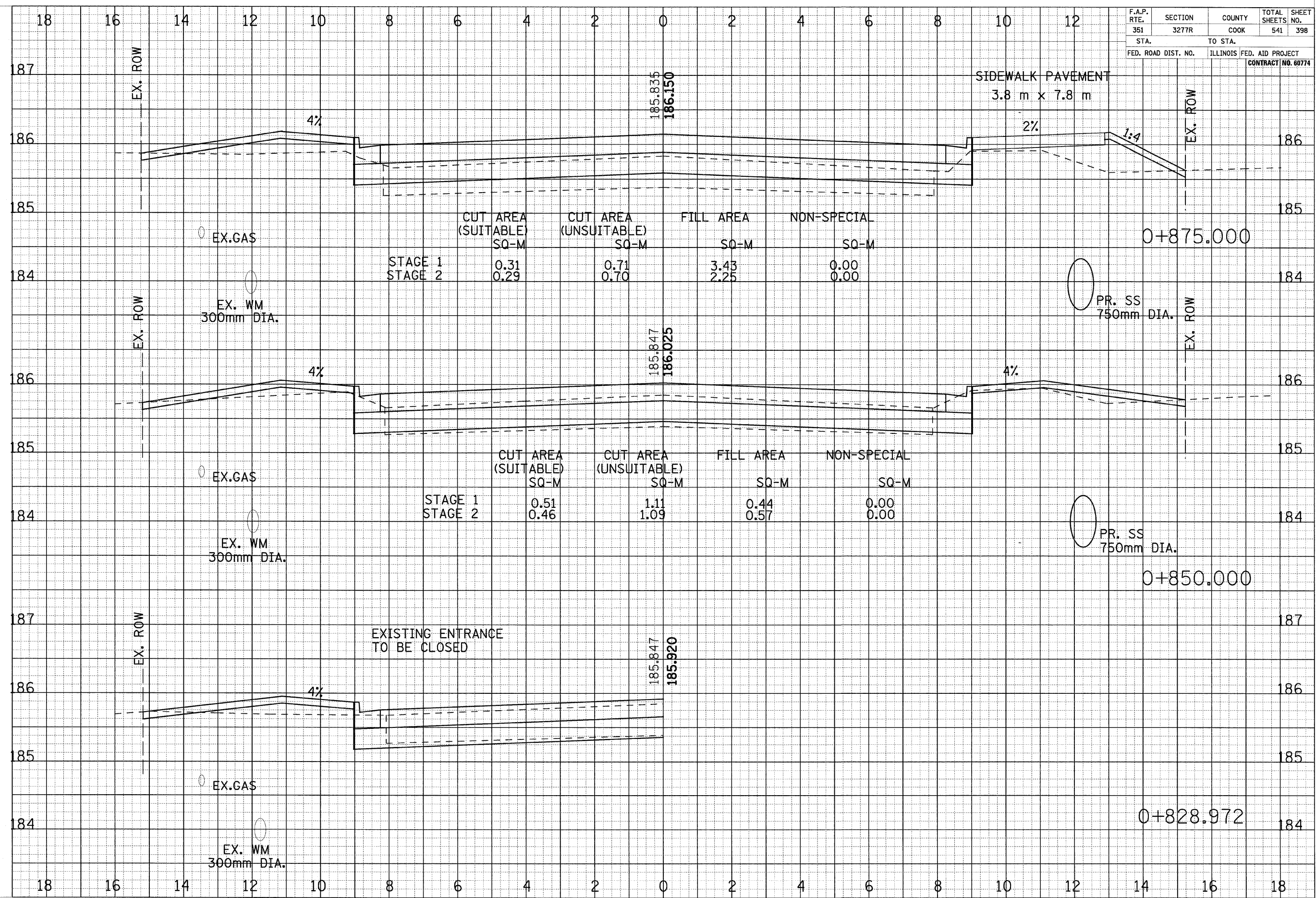

F.A.P. RTE. 351	SECTION 3277R	COUNTY COOK	TOTAL SHEETS 541	SHEET NO. 399
STA. FED. ROAD DIST. NO.		TO STA. ILLINOIS FED. AID PROJECT		
CONTRACT NO. 60774				

DATE: _____
 BY: _____
 SURVEYED _____
 PLOTTED _____
 NOTE BOOK _____
 REVISION DATE _____
 AREAS CHECKED _____

DATE: _____
 BY: _____
 SURVEYED _____
 PLOTTED _____
 NOTE BOOK _____
 REVISION DATE _____
 AREAS CHECKED _____

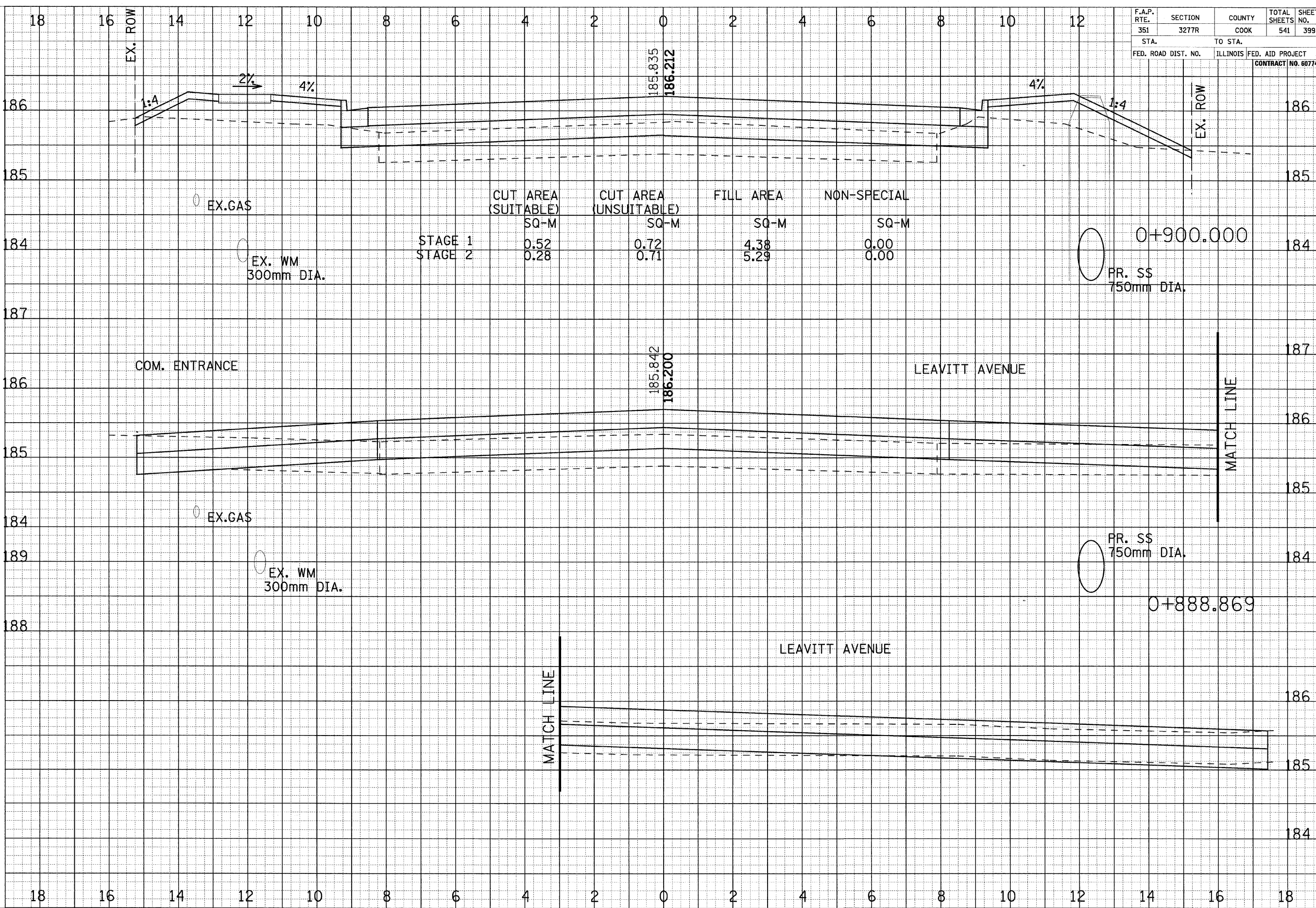

CROSS SECTIONS - US ROUTE 6

DATE _____ BY _____
 SURVEYED _____ PLOTTED _____
 NOTE BOOK _____ DATE _____
 NO. _____ AREAS CHECKED _____

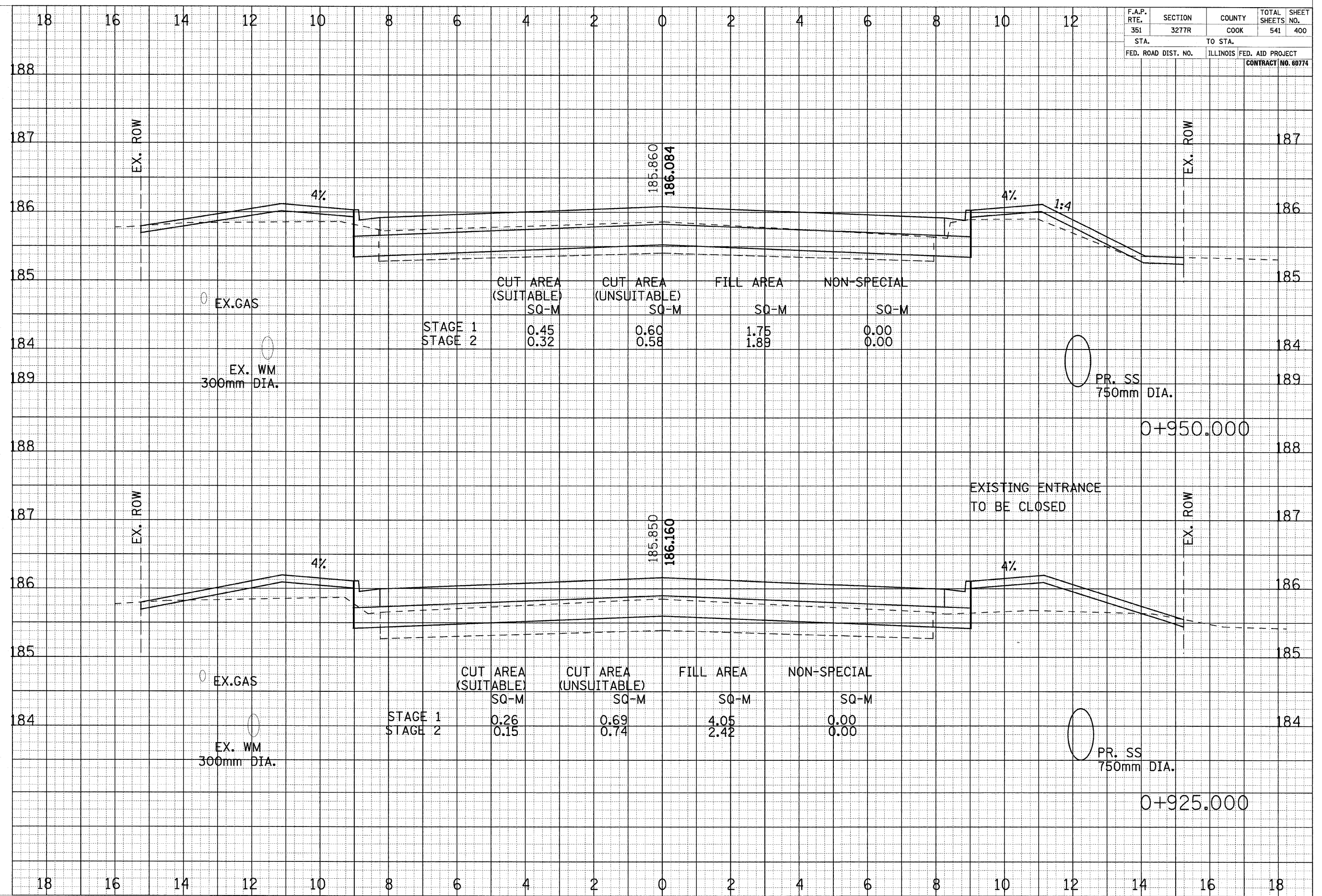

DATE _____ BY _____
 SURVEYED _____ PLOTTED _____
 NOTE BOOK _____ DATE _____
 NO. _____ AREAS CHECKED _____

	CUT AREA (SUITABLE) SQ-M	CUT AREA (UNSUITABLE) SQ-M	FILL AREA SQ-M	NON-SPECIAL SQ-M
STAGE 1	0.45	0.60	1.75	0.00
STAGE 2	0.32	0.58	1.89	0.00

	CUT AREA (SUITABLE) SQ-M	CUT AREA (UNSUITABLE) SQ-M	FILL AREA SQ-M	NON-SPECIAL SQ-M
STAGE 1	0.26	0.69	4.05	0.00
STAGE 2	0.15	0.74	2.42	0.00