

F.A.P. RTE.	SECTION	COUNTY	TOTAL SHEETS	SHEET NO.
341	N-4-C-1	KANE	32	1
FED. ROAD DIST. NO.	ILLINOIS	CONTRACT NO. 60D72		

STATE OF ILLINOIS  
DEPARTMENT OF TRANSPORTATION  
DIVISION OF HIGHWAYS

**PROPOSED  
HIGHWAY PLANS**

FAP 341 / IL. 72  
SECTION: N-4-C-1  
OVER I-90  
BRIDGE DECK OVERLAY  
KANE COUNTY  
PROJECT: *ESP-0341(046)*  
C-91-091-08  
RUTLAND TOWNSHIP  
R. 7 E.

FOR INDEX OF SHEETS, SEE SHEET NO. 2

**DESIGN DESIGNATION:**  
OTHER PRINCIPAL ARTERIAL  
POSTED SPEED : 40 M.P.H.  
2007 ADT = 13,500  
2021 ADT = 12,150

**MUNICIPALITY INVOLVED:**  
VILLAGE OF GILBERTS

D-91-091-08



LOCATION OF SECTION INDICATED THUS: - [black rectangle] -

**PROJECT:**  
F.A.P. 341 / IL. 72  
OVER I-90  
S.N. 045-0074

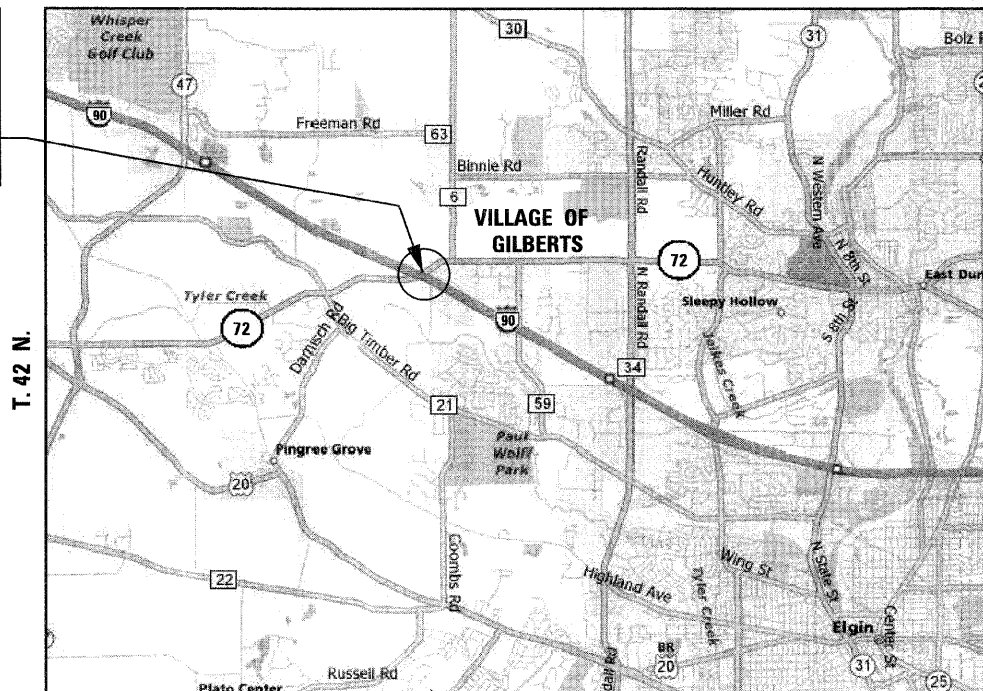

**GROSS LENGTH OF PROJECT = 393.00 FEET = 0.074 MILES**  
**NET LENGTH OF PROJECT = 393.00 FEET = 0.074 MILES**

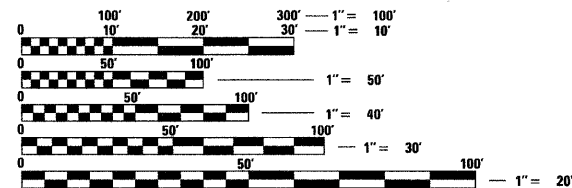

FULL SIZE PLANS HAVE BEEN PREPARED USING STANDARD ENGINEERING SCALES. REDUCED SIZED PLANS WILL NOT CONFORM TO STANDARD SCALES. IN MAKING MEASUREMENTS ON REDUCED PLANS, THE ABOVE SCALES MAY BE USED.

J.U.L.I.E.  
JOINT UTILITY LOCATING INFORMATION FOR EXCAVATORS  
1-800-892-0123  
OR 811

DISTRICT ONE - DESIGN  
PROJECT MANAGER : ISAAC KWARTENG (847) 705-4230  
PROJECT ENGINEER : RON ZENAROSA (847) 705-4212

CONTRACT NO. 60D72

STATE OF ILLINOIS  
DEPARTMENT OF TRANSPORTATION  
DIVISION OF HIGHWAYS

SUBMITTED JANUARY 14, 2009

Diana M. O'Keefe  
DEPUTY DIRECTOR OF HIGHWAYS, REGION ONE ENGINEER

March 13, 2009  
Charles G. Ingersoll  
ENGINEER OF DESIGN AND ENVIRONMENT

March 13, 2009  
Christine M. Reed  
DIRECTOR OF HIGHWAYS, CHIEF ENGINEER



Birinder S. Sachdeva January 12, 2009  
BIRINDER S. SACHDEVA, P.E. DATE  
EXPIRES: 11-30-2009



Bhadrach N. Shah 01/12/09  
BHADRACH N. SHAH, S.E., P.E. DATE  
EXPIRES: 11-30-2010

DESIGN SECTION ENGINEER :  
**CR & A**  
CHRISTIAN-ROGE & ASSOCIATES, INC.  
ENGINEERS - PLANNERS - SURVEYORS  
211 W. WACKER DRIVE CHICAGO, IL 60606  
TELEPHONE: 312 372-2023

**PRINTED BY THE AUTHORITY  
OF THE STATE OF ILLINOIS**

**INDEX OF SHEETS**

1	COVER SHEET
2	INDEX OF SHEETS, LIST OF STATE STANDARDS AND GENERAL NOTES IL 72
3	SUMMARY OF QUANTITIES IL 72
4	TYPICAL SECTIONS AND DETAILS IL 72
5	ALIGNMENT, TIES AND PAVEMENT MARKINGS IL 72
6	EXISTING CONDITIONS AND PROPOSED PLAN AND PROFILE IL 72
7	CONSTRUCTION STAGING AND MAINTENANCE OF TRAFFIC NOTES AND DETAILS IL 72
8	SUGGESTED TRAFFIC CONTROL AND STAGING PLAN IL 72
9 - 10	TEMPORARY BRIDGE TRAFFIC SIGNAL PLANS
11	TEMPORARY LIGHTING PLAN IL 72
12	TEMPORARY LIGHTING NOTES AND DETAILS IL 72
13 - 20	STRUCTURAL DRAWINGS IL 72 OVER I-90
21	BUTT JOINT AND HMA TAPER DETAIL
22	TRAFFIC CONTROL AND PROTECTION FOR SIDE ROADS, INTERSECTIONS AND DRIVEWAYS
23	TEMPORARY LIGHT POLE DETAILS
24	TEMPORARY AERIAL CABLE INSTALLATION
25	TYPICAL APPLICATIONS RAISED REFLECTIVE PAVEMENT MARKERS (SNOW-PLOW RESISTANT)
26	DISTRICT ONE TYPICAL PAVEMENT MARKINGS
27 - 28	ISTHA STANDARD - CONSTRUCTION SIGNS
29 - 31	ISTHA STANDARD - LANE CLOSURE DETAILS
32	ISTHA STANDARD - TEMPORARY GORE DETAILS AND SHOULDER CLOSURE DETAILS

**LIST OF STATE STANDARDS**

STANDARD NO.	DESCRIPTION
000001-05	STANDARD SYMBOLS, ABBREVIATIONS AND PATTERNS
701201-03	LANE CLOSURE, 2L, 2W, DAY ONLY, FOR SPEEDS > 45 MPH
701316-04	LANE CLOSURE, 2L, 2W, BRIDGE REPAIR, FOR SPEEDS > 45 MPH
701901-01	TRAFFIC CONTROL DEVICES
880001-01	SPAN WIRE MOUNTED SIGNALS AND FLASHING BEACON INSTALLATION

**GENERAL NOTES**

1. PLAN DIMENSIONS AND DETAILS RELATIVE TO EXISTING PLANS ARE SUBJECT TO ROUTINE VARIATIONS. THE CONTRACTOR SHALL FIELD VERIFY EXISTING DIMENSIONS AND DETAILS AFFECTING NEW CONSTRUCTION AND MAKE NECESSARY APPROVED ADJUSTMENTS PRIOR TO CONSTRUCTION OR ORDERING MATERIALS. SUCH VARIATIONS SHALL NOT BE CAUSE FOR ADDITIONAL COMPENSATION FOR A CHANGE IN THE SCOPE OF THE WORK, HOWEVER, THE CONTRACTOR WILL BE PAID FOR THE QUANTITY ACTUALLY FURNISHED BASED UPON THE UNIT PRICE.
2. FORTY-EIGHT HOURS BEFORE STARTING EXCAVATION, THE CONTRACTOR WILL CALL J.U.L.I.E. (1-800-892-0123) OR 811 TO HAVE THE LOCATION OF EXISTING UTILITIES STAKED.
3. THE CONTRACTOR WILL NOT BE ALLOWED TO SET UP A YARD OR FIELD OFFICE ON STATE PROPERTY WITHOUT WRITTEN PERMISSION FROM THE DEPARTMENT.
4. SAW CUTTING PRIOR TO ANY REMOVAL ITEMS NOTED ON THE PLANS OR DIRECTED BY THE ENGINEER SHALL BE CONSIDERED INCLUDED IN THE COST OF THE ITEMS BEING REMOVED.
5. DO NOT SCALE PLANS FOR CONSTRUCTION DIMENSIONS.
6. THE CONTRACTOR SHALL USE CARE IN REMOVING OR EXCAVATING NEAR ALL EXISTING ITEMS WHICH WILL REMAIN. ANY DAMAGE DONE TO EXISTING ITEMS BY THE CONTRACTOR SHALL BE REPAIRED AT THE CONTRACTOR'S EXPENSE.
7. WHEN ARTIFICIAL LIGHTING IS UTILIZED IN NIGHT OPERATIONS, THE CONTRACTOR SHALL EXERCISE THE UTMOST PRECAUTIONS IN PREVENTING ADVERSE VISIBILITY TO THE MOTORING PUBLIC AS WELL AS ADJOINING RESIDENTIAL AREAS.
8. THE CONTRACTOR SHALL OBTAIN ALL NECESSARY PERMITS, AS REQUIRED, PRIOR TO COMMENCING WITH CONSTRUCTION.
9. THE COST OF THE TOLLWAY PERMIT AND BOND AND THE COST OF THE TRAFFIC CONTROL AND PROTECTION ON I-90 (NORTHWEST TOLLWAY) TO INSTALL AND REMOVE THE PROTECTIVE SHIELDING SHALL BE INCLUDED IN THE BID PRICE FOR TRAFFIC CONTROL AND PROTECTION (EXPRESSWAYS).
10. THE CONTRACTOR SHALL CONTACT THE TRAFFIC CONTROL SUPERVISOR AT (847) 705-4470 A MINIMUM OF 72 HOURS PRIOR TO THE PLACEMENT OF ANY TEMPORARY TRAFFIC CONTROL DEVICES.
11. THE CONTRACTOR SHALL CONTACT DAN CHIARUGI, THE AREA TRAFFIC FIELD ENGINEER, AT (847) 741-9857 TWO (2) WEEKS PRIOR TO THE PLACEMENT OF PERMANENT PAVEMENT MARKINGS.
12. ALL DAMAGE TO EXISTING PAVEMENT MARKINGS OUTSIDE THE REMOVAL LINE SHOWN ON THE PLANS SHALL BE REPLACED AT THE CONTRACTOR'S EXPENSE.
13. ILLINOIS DEPARTMENT OF TRANSPORTATION SHALL COORDINATE WITH THE VILLAGE OF GILBERTS TO ENSURE APPROPRIATE SIGNAL TIMING FOR THE SATISFACTORY MOVEMENTS OF WESTBOUND RUSH HOUR AND THAT THE SUBDIVISION ENTRANCES SHALL NOT BE BLOCKED BY VEHICLES DURING HOURS OF HEAVY TRAFFIC.
14. THE COST FOR ANY TEMPORARY RAMPS SHALL BE INCLUDED IN THE CONTRACT PRICE PER SQUARE YARD FOR HOT MIX ASPHALT SURFACE REMOVAL - BUTT JOINT.

FILE NAME = 60D72 index.dgn  
PLOT DATE = 1/15/2009



**CHRISTIAN-ROGE & ASSOCIATES, INC.**  
ENGINEERS-PLANNERS-SURVEYORS  
211 WEST WACKER DRIVE  
CHICAGO, ILLINOIS 60606  
PHONE: (312)372-2023 FAX: (312)372-5274

DESIGNED -	S.J.P.	REVISED -	
DRAWN -	A.Y.	REVISED -	
CHECKED -	E.J.M.	REVISED -	
DATE -	JANUARY 15, 2009	REVISED -	

**STATE OF ILLINOIS  
DEPARTMENT OF TRANSPORTATION**

**INDEX OF SHEETS, LIST OF STATE STANDARDS AND GENERAL NOTES  
IL 72**

SCALE: NONE SHEET NO. 1 OF 1 SHEETS STA. 178+00 TO STA. 184+00

F.A.P. RTE.	SECTION	COUNTY	TOTAL SHEETS	SHEET NO.
341	N-4-C-1	KANE	32	2
			<b>CONTRACT NO. 60D72</b>	

FED. ROAD DIST. NO. 4 ILLINOIS FED. AID PROJECT

SUMMARY OF QUANTITIES			URBAN 100% FED.	CONSTRUCTION TYPE CODE
CODE NO	ITEM	UNIT	TOTAL QUANTITIES	IL 72 BRIDGE SFTY-2A
40600200	BITUMINOUS MATERIALS (PRIME COAT)	TON	1	1
40600982	HOT-MIX ASPHALT SURFACE REMOVAL - BUTT JOINT	SQ YD	27	27
40603340	HOT-MIX ASPHALT SURFACE COURSE, MIX "D", N70	TON	32	32
44000155	HOT-MIX ASPHALT SURFACE REMOVAL, 1 1/2"	SQ YD	381	381
50102400	CONCRETE REMOVAL	CU YD	65.0	65.0
<del>50157300</del>	<del>PROTECTIVE SHIELD</del>	<del>SQ YD</del>	<del>700</del>	<del>700</del>
50300255	CONCRETE SUPERSTRUCTURE	CU YD	65.0	65.0
50300260	BRIDGE DECK GROOVING	SQ YD	832	832
50300300	PROTECTIVE COAT	SQ YD	961	961
50800205	REINFORCEMENT BARS, EPOXY COATED	POUND	15,190	15,190
50800515	BAR SPLICERS	EACH	122	122
52000110	PREFORMED JOINT STRIP SEAL	FOOT	225	225
67000400	ENGINEER'S FIELD OFFICE, TYPE A	CAL MO	6	6
67100100	MOBILIZATION	L SUM	1	1
70100100	TRAFFIC CONTROL AND PROTECTION, STANDARD 701316	EACH	1	1
70100450	TRAFFIC CONTROL AND PROTECTION, STANDARD 701201	L SUM	1	1
70106800	CHANGEABLE MESSAGE SIGN	CAL MO	2	2
* 78008210	POLYUREA PAVEMENT MARKING TYPE I - LINE 4"	FOOT	1,179	1,179
* 78100100	RAISED REFLECTIVE PAVEMENT MARKER	EACH	4	4
* 78100105	RAISED REFLECTIVE PAVEMENT MARKER (BRIDGE)	EACH	6	6
78300100	PAVEMENT MARKING REMOVAL	SQ FT	393	393
78300200	RAISED REFLECTIVE PAVEMENT MARKER REMOVAL	EACH	10	10

\* SPECIALTY ITEM

SUMMARY OF QUANTITIES			URBAN 100% FED.	CONSTRUCTION TYPE CODE
CODE NO	ITEM	UNIT	TOTAL QUANTITIES	IL 72 BRIDGE SFTY-2A
80400100	ELECTRIC SERVICE INSTALLATION	EACH	1	1
80400200	ELECTRIC UTILITY SERVICE CONNECTION	L SUM	1	1
* 81800300	AERIAL CABLE, 3-1/C NO. 2 WITH MESSENGER WIRE	FOOT	1,608	1,608
* 82103400	LUMINAIRE, SODIUM VAPOR, HORIZONTAL MOUNT, PHOTO-CELL CONTROL, 400 WATT	EACH	8	8
* 83057355	LIGHT POLE, WOOD, 60 FOOT, CLASS 4, WITH 15FT MAST ARM	EACH	8	8
* 83057435	LIGHT POLE, WOOD, 80 FOOT, CLASS 3, WITH 15FT MAST ARM	EACH	2	2
* 83057430	LIGHT POLE, WOOD, 80 FOOT, CLASS 3	EACH	1	1
* 84100110	REMOVAL OF TEMPORARY LIGHTING UNITS	EACH	8	8
* X0322141	REMOVE TEMPORARY WOOD POLE	EACH	1	1
X0322467	TEMPORARY INFORMATION SIGNING FOR LANE CLOSURE	SQ FT	48	48
* X0323574	MAINTENANCE OF LIGHTING SYSTEM	CAL MO	6	6
X0325775	WET REFLECTIVE TEMPORARY TAPE, TYPE III, 4 INCH	FOOT	1,481	1,481
<del>* X0325867</del>	<del>COMBINATION POLE MOUNTED ELECTRIC SERVICE BOX</del>	<del>EACH</del>	<del>1</del>	<del>1</del>
X7011015	TRAFFIC CONTROL AND PROTECTION (EXPRESSWAYS)	L SUM	1	1
* X8900005	TEMPORARY BRIDGE TRAFFIC SIGNAL INSTALLATION	EACH	1	1
* XX006937	GROUND ROD, 5/8" DIA. x 10 FT.	EACH	2	2
Z0006229	BRIDGE DECK HYDRO-SCARIFICATION 3"	SQ YD	901	901
Z0016002	DECK SLAB REPAIR (FULL DEPTH, TYPE II)	SQ YD	44	44
X0326346	BRIDGE DECK LATEX CONCRETE OVERLAY, 3 INCHES	SQ YD	901	901
* X0326135	ELECTRIC SERVICE DISCONNECT, LIGHTING AND TRAFFIC SIGNAL	EACH	1	1

\* SPECIALTY ITEM

HOT-MIX ASPHALT MIXTURE REQUIREMENTS		
MIXTURE TYPE	AC TYPE	AIR VOIDS
PAVEMENT RESURFACING		
HOT-MIX ASPHALT SURFACE COURSE, MIX "D", N70 (IL 9.5 mm), 1 1/2"	PG 64-22	4% @ 70 Gyr.

THE UNIT WEIGHT USED TO CALCULATE HMA MIXTURE QUANTITIES IS 112 LBS/SQ YD/IN.  
 \* WHEN RAP EXCEEDS 20%, THE NEW ASPHALT BINDER IN THE MIX SHALL BE PG 58-22.

**NOTES:**

- EXISTING PAVEMENT TO BE OVERLAID WILL BE CLEANED AND PRIMED PER ARTICLE 407.06 OF THE 2007 STANDARD SPECIFICATIONS.

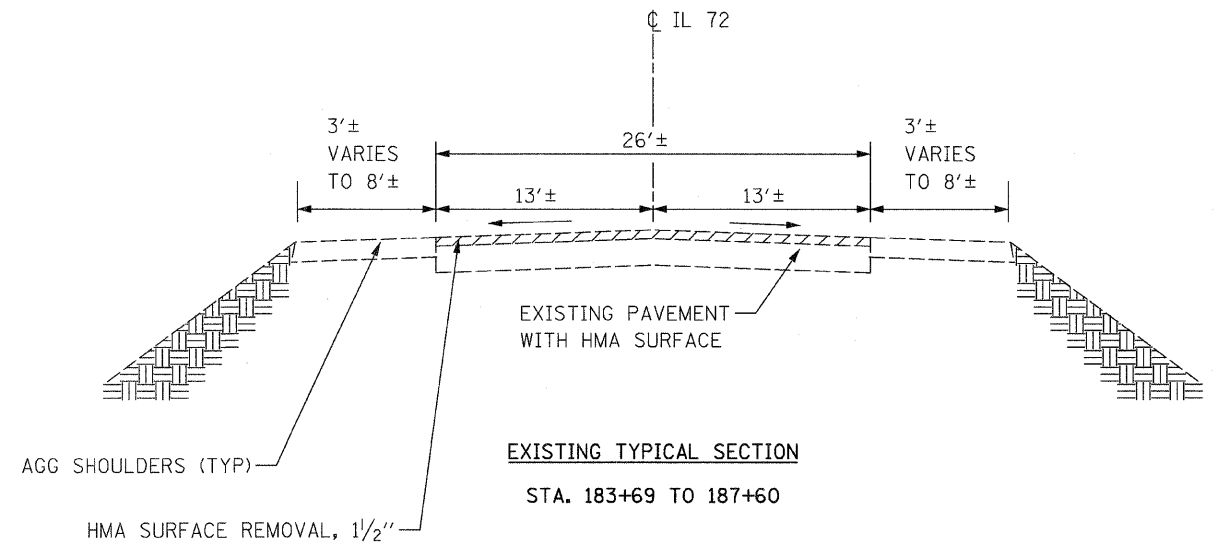

BRIDGE OMISSION:  
 STA. 184+27.70 TO STA. 187+00.01

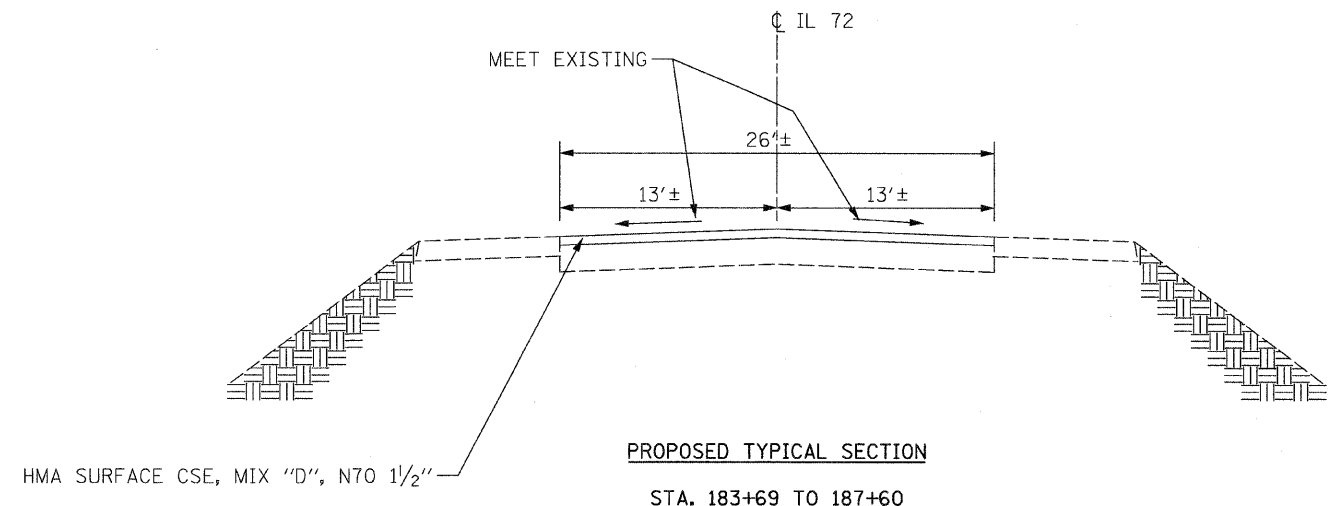

BRIDGE OMISSION:  
 STA. 184+27.70 TO STA. 187+00.01

FILE NAME = 60D72 typ.dgn  
 PLOT DATE = 1/15/2009



CHRISTIAN-ROGE & ASSOCIATES, INC.  
 ENGINEERS-PLANNERS-SURVEYORS  
 211 WEST WACKER DRIVE  
 CHICAGO, ILLINOIS 60606  
 PHONE: (312)372-2023 FAX: (312)372-5274

DESIGNED - S.J.P.	REVISED -
DRAWN - A.Y.	REVISED -
CHECKED - E.J.M.	REVISED -
DATE - JANUARY 15, 2009	REVISED -

STATE OF ILLINOIS  
 DEPARTMENT OF TRANSPORTATION

TYPICAL SECTIONS & DETAILS  
 IL 72

SCALE: NONE SHEET NO. 1 OF 1 SHEETS STA. 179+00 TO STA. 194+00

F.A.P. RTE.	SECTION	COUNTY	TOTAL SHEETS	SHEET NO.
341	N-4-C-1	KANE	32	4
CONTRACT NO. 60D72				
FED. ROAD DIST. NO. 1 ILLINOIS FED. AID PROJECT				

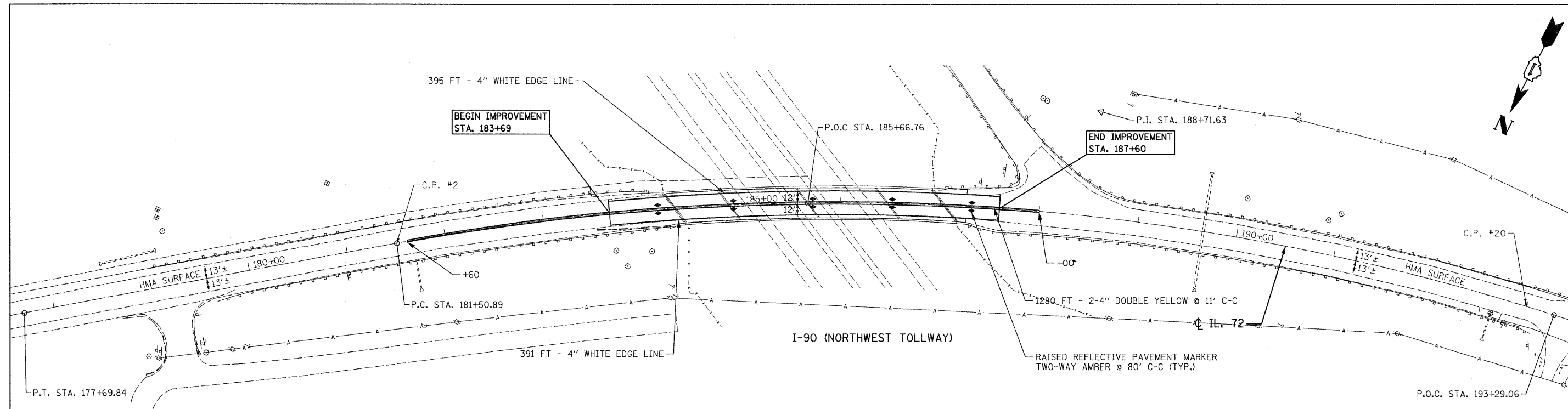

**PAVEMENT MARKING NOTES:**

- ALL PAVEMENT MARKINGS ON BRIDGE DECK AND PAVEMENT SHALL BE POLYUREA, TYPE I.

CURVE DATA	
P.C. STA.	181+50.89
P.I. STA.	188+71.63
P.O.C. STA.	193+29.06
P.T. STA.	195+51.24
R	= 2,400.00'
L	= 1,400.35'
Δ	= 2° 23' 14" (RT)
E	= 105.89'
D	= 2° 23' 14"
T	= 720.74'

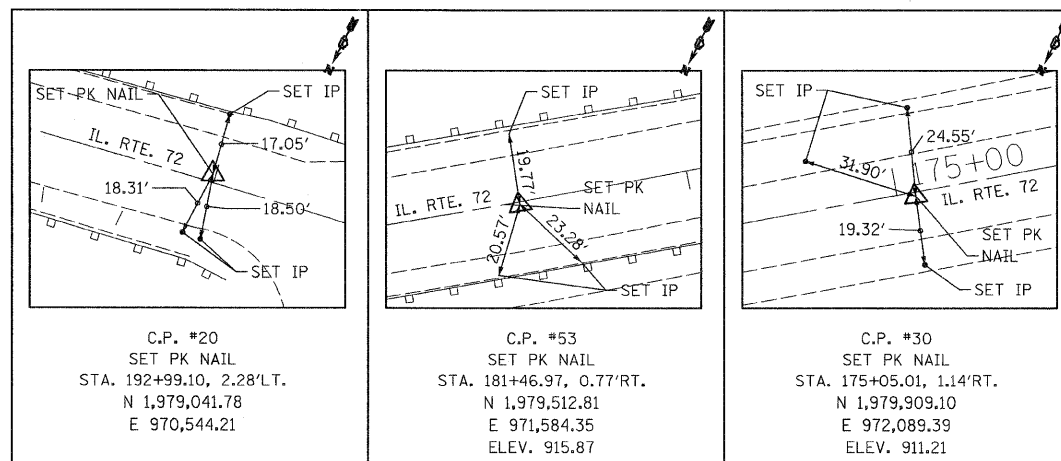

CENTERLINE ALIGNMENT				
PN	POINT	NORTHING	EASTING	STATION
5000	P. O. T.	1,979,979.67	972,181.75	173+88.78
5004	P. O. T.	1,979,745.34	971,881.27	177+69.84
5001	P. C.	1,979,511.01	971,580.78	181+50.89
5002	P. C. C.	1,979,285.11	971,232.23	185+66.79
5005	P. O. C.	1,979,038.73	970,514.30	193+29.06
5003	P. T.	1,979,011.00	970,293.93	195+51.24

FILE NAME = 60D72 align pmdgn  
PLOT DATE = 1/15/2009

**CHRISTIAN-ROGE & ASSOCIATES, INC.**  
ENGINEERS-PLANNERS-SURVEYORS  
211 WEST WACKER DRIVE  
CHICAGO, ILLINOIS 60606  
PHONE: (312)372-2023 FAX: (312)372-5274

DESIGNED -	S.J.P.	REVISED -	
DRAWN -	A.Y.	REVISED -	
CHECKED -	E.J.M.	REVISED -	
DATE -	JANUARY 15, 2009	REVISED -	

**STATE OF ILLINOIS  
DEPARTMENT OF TRANSPORTATION**

**ALIGNMENT, TIES, AND PAVEMENT MARKINGS  
IL 72**

SCALE: 1" = 50' SHEET NO. 1 OF 1 SHEETS STA. 179+00 TO STA. 194+00

F.A.P. RTE.	SECTION	COUNTY	TOTAL SHEETS	SHEET NO.
341	N-4-C-1	KANE	32	5
CONTRACT NO. 60D72				
FED. ROAD DIST. NO. 1 ILLINOIS FED. AID PROJECT				

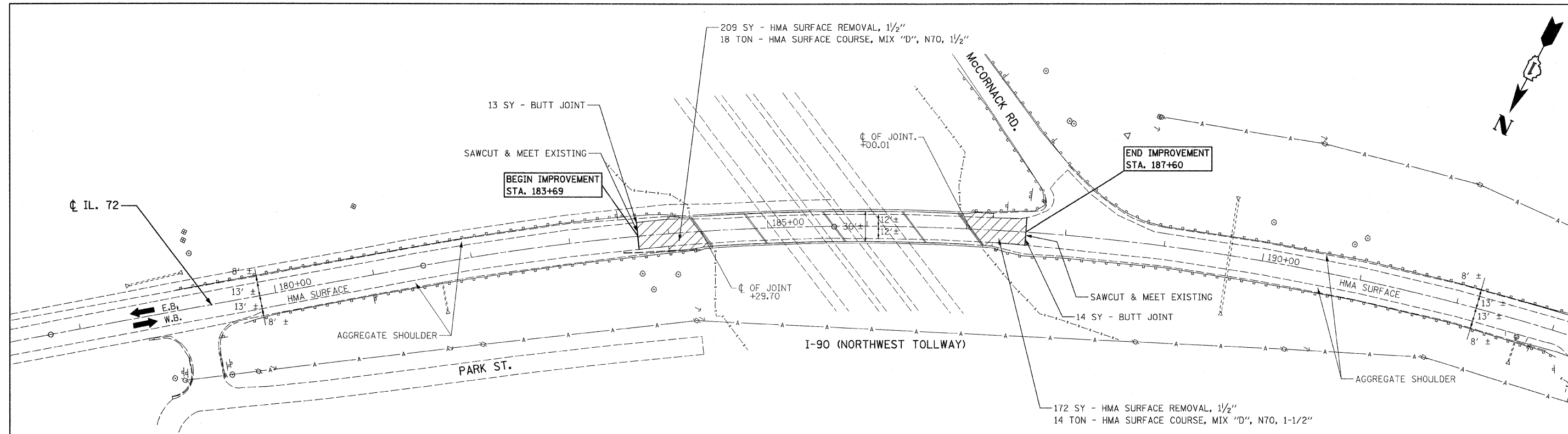

EXISTING CONDITIONS & PROPOSED PLAN

BM PN 79 ELEV. 919.66  
 SQUARE CUT @ TOP OF N.E. BRIDGE WALL  
 STA. 187+03.05, 18.47' LT.

BM PN 185 ELEV. 919.57  
 SQUARE CUT @ TOP OF S.W. BRIDGE WALL  
 STA. 184+59.40, 18.31' RT.

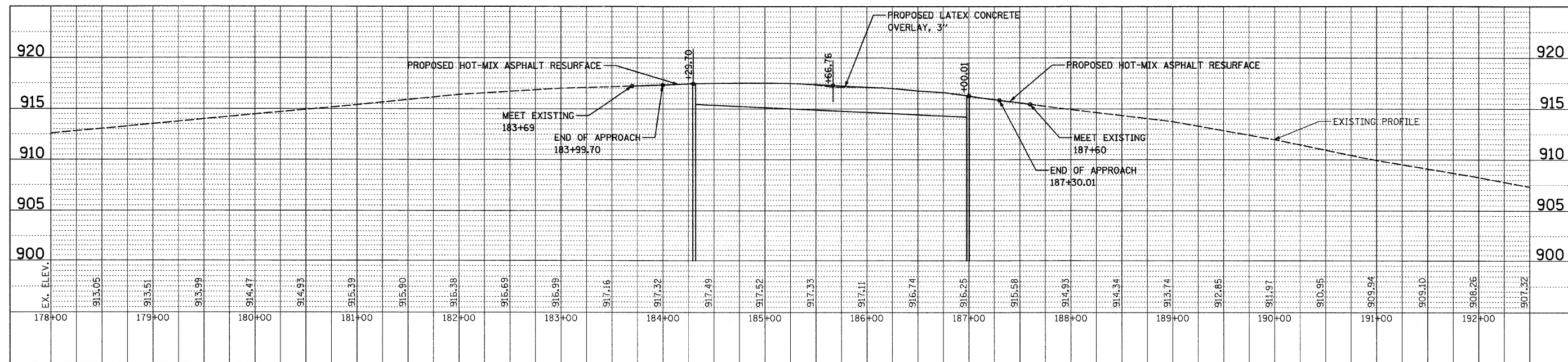

FILE NAME = 60072 pp.dgn  
 PLOT DATE = 1/15/2009

**CHRISTIAN-ROGE & ASSOCIATES, INC.**  
 ENGINEERS-PLANNERS-SURVEYORS  
 211 WEST WACKER DRIVE  
 CHICAGO, ILLINOIS 60606  
 PHONE: (312)372-2023 FAX: (312)372-5274

DESIGNED - S.J.P.	REVISED -
DRAWN - A.Y.	REVISED -
CHECKED - E.J.M.	REVISED -
DATE - JANUARY 15, 2009	REVISED -

STATE OF ILLINOIS  
 DEPARTMENT OF TRANSPORTATION

EXISTING CONDITIONS AND PROPOSED PLAN AND PROFILE  
 IL 72

SCALE: 1" = 50' SHEET NO. 1 OF 1 SHEETS STA. 179+00 TO STA. 194+00

F.A.P. RTE. 341	SECTION N-4-C-1	COUNTY KANE	TOTAL SHEETS 32	SHEET NO. 6
CONTRACT NO. 60D72				
FED. ROAD DIST. NO. 1 ILLINOIS FED. AID PROJECT				

## SUGGESTED STAGING AND MAINTENANCE OF TRAFFIC

### CONSTRUCTION STAGING

#### PRE-STAGE

- INSTALL TEMPORARY LIGHTING, TEMPORARY BRIDGE TRAFFIC SIGNAL AND TRAFFIC CONTROL DEVICES FOR STAGE I.
- INSTALL PROTECTIVE SHIELDING.

#### STAGE I - WESTBOUND LANES

- REMOVE EXISTING CONCRETE OVERLAY, PERFORM DECK SLAB REPAIRS, RECONSTRUCT TRANSVERSE JOINTS, AND PLACE LATEX CONCRETE WEARING SURFACE.

#### STAGE II - EASTBOUND LANES

- REMOVE EXISTING CONCRETE OVERLAY, PERFORM DECK SLAB REPAIRS, RECONSTRUCT TRANSVERSE JOINTS, AND PLACE LATEX CONCRETE WEARING SURFACE.
- SCARIFY AND RESURFACE BRIDGE APPROACH PAVEMENT.
- REMOVE PROTECTIVE SHIELDING.

### MAINTENANCE OF TRAFFIC

#### PRE-STAGE

- USE DAILY LANE CLOSURES TO INSTALL TEMPORARY LIGHTING AND SIGNALS AND PLACE TRAFFIC CONTROL DEVICES FOR STAGE I. USE IDOT STANDARD 701201 - LANE CLOSURE, 2L, 2W, DAY ONLY, FOR SPEEDS > 45 MPH.
- USE NIGHTTIME LANE CLOSURES TO INSTALL PROTECTIVE SHIELDING. USE ISHTA SECTION-E STANDARDS.

#### STAGE I

- CLOSE WESTBOUND LANE AS SHOWN ON THE SUGGESTED TRAFFIC CONTROL AND STAGING PLAN AND ON IDOT STANDARD 701316 - LANE CLOSURE, 2L, 2W BRIDGE REPAIR FOR SPEEDS > 45 MPH.
- MAINTAIN ONE-LANE TWO-WAY TRAFFIC ON EASTBOUND PAVEMENT ACROSS BRIDGE.

#### STAGE II

- CLOSE EASTBOUND LANE AS SHOWN ON THE SUGGESTED TRAFFIC CONTROL AND STAGING PLAN AND ON IDOT STANDARD 701316 - LANE CLOSURE, 2L, 2W BRIDGE REPAIR FOR SPEEDS > 45 MPH.
- SHIFT ONE-LANE TWO-WAY TRAFFIC TO WESTBOUND PAVEMENT ACROSS BRIDGE.
- REMOVE TEMPORARY BRIDGE TRAFFIC SIGNALS, LIGHTING AND TRAFFIC CONTROL DEVICES USING DAILY LANE CLOSURES. SEE IDOT STANDARD 701201 - LANE CLOSURE, 2L, 2W, DAY ONLY, FOR SPEEDS > 45 MPH.
- USE NIGHTTIME LANE CLOSURES TO REMOVE PROTECTIVE SHIELDING. USE ISHTA SECTION-E STANDARDS.

## TRAFFIC CONTROL GENERAL NOTES

1. USE SUGGESTED TRAFFIC CONTROL AND STAGING PLAN IN CONJUNCTION WITH STANDARD 701316.
2. CONTRACTOR SHALL MAINTAIN SATISFACTORY INGRESS AND EGRESS TO ADJACENT PROPERTIES THROUGHOUT THE CONSTRUCTION.
3. INSTALL TEMPORARY SIGN PANEL ASSEMBLY, AS DIRECTED BY THE ENGINEER, TO BE PAID FOR BY ITEM "TEMPORARY INFORMATION SIGNING FOR LANE CLOSURE".
4. ALL TEMPORARY PAVEMENT MARKING SHALL BE WET REFLECTIVE TEMPORARY TAPE, TYPE III.
5. THE FIRST TWO SIGNS ENTERING THE WORK ZONE SHALL HAVE MONO-DIRECTIONAL FLASHING BEACONS.
6. THE CONTRACTOR SHALL NOT MOUNT TEMPORARY SIGNS ONTO OR OVER EXISTING SIGNS.
7. THE COST OF ADDITIONAL SIGNING SHALL BE INCLUDED THE CONTRACT PRICE FOR TRAFFIC CONTROL AND PROTECTION, STANDARD 701316.

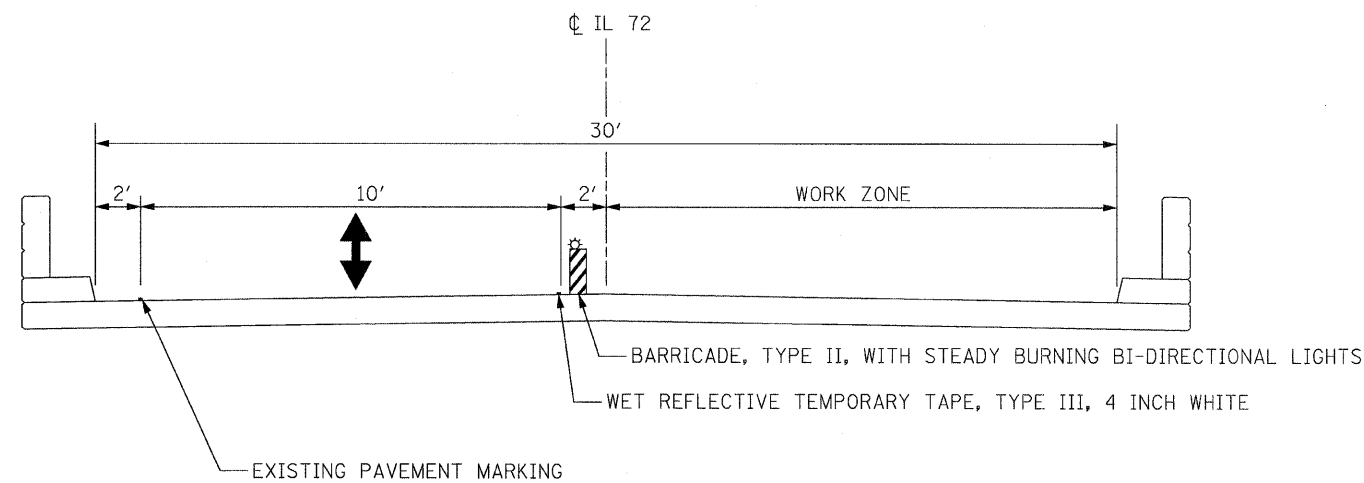

TYPICAL SECTION - STAGE I

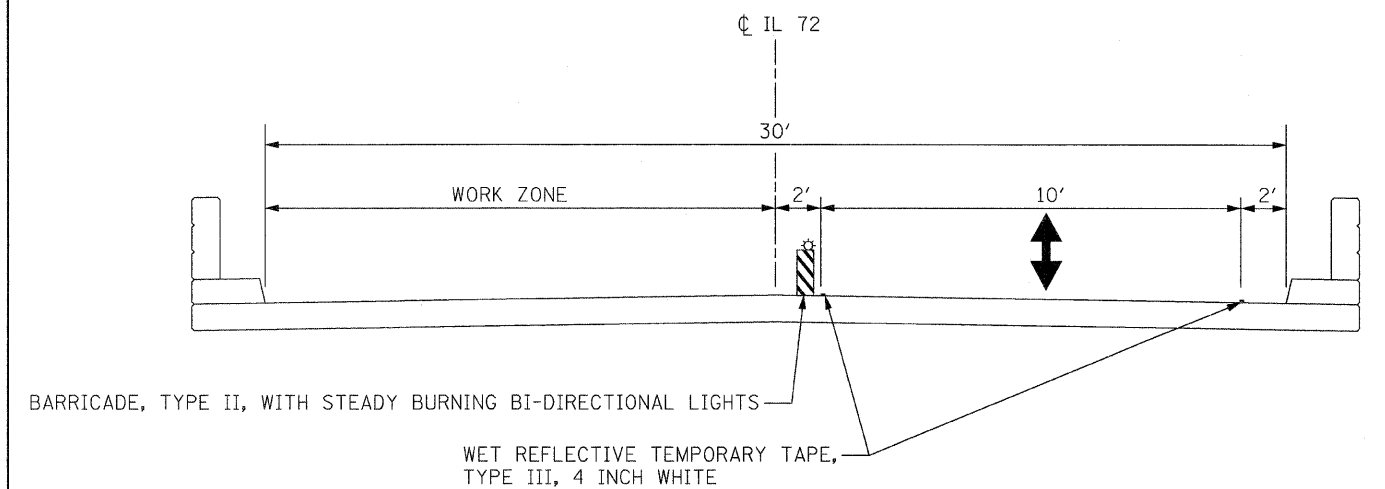

TYPICAL SECTION - STAGE II

FILE NAME = 60072 staging1.dgn  
PLOT DATE = 1/15/2009



**CHRISTIAN-ROGE & ASSOCIATES, INC.**  
ENGINEERS-PLANNERS-SURVEYORS  
211 WEST WACKER DRIVE  
CHICAGO, ILLINOIS 60606  
PHONE: (312)372-2023 FAX: (312)372-5274

DESIGNED	- S.J.P.	REVISED	-
DRAWN	- A.Y.	REVISED	-
CHECKED	- E.J.M.	REVISED	-
DATE	- JANUARY 15, 2009	REVISED	-

**STATE OF ILLINOIS  
DEPARTMENT OF TRANSPORTATION**

**SUGGESTED MAINTENANCE OF TRAFFIC NOTES AND DETAILS  
IL 72**

SCALE: NONE    SHEET NO. 1 OF 2 SHEETS    STA. 179+00    TO STA. 194+00

F.A.P. RTE.	SECTION	COUNTY	TOTAL SHEETS	SHEET NO.
341	N-4-C-1	KANE	32	7
CONTRACT NO. 60D72				
FED. ROAD DIST. NO. 1   ILLINOIS FED. AID PROJECT				

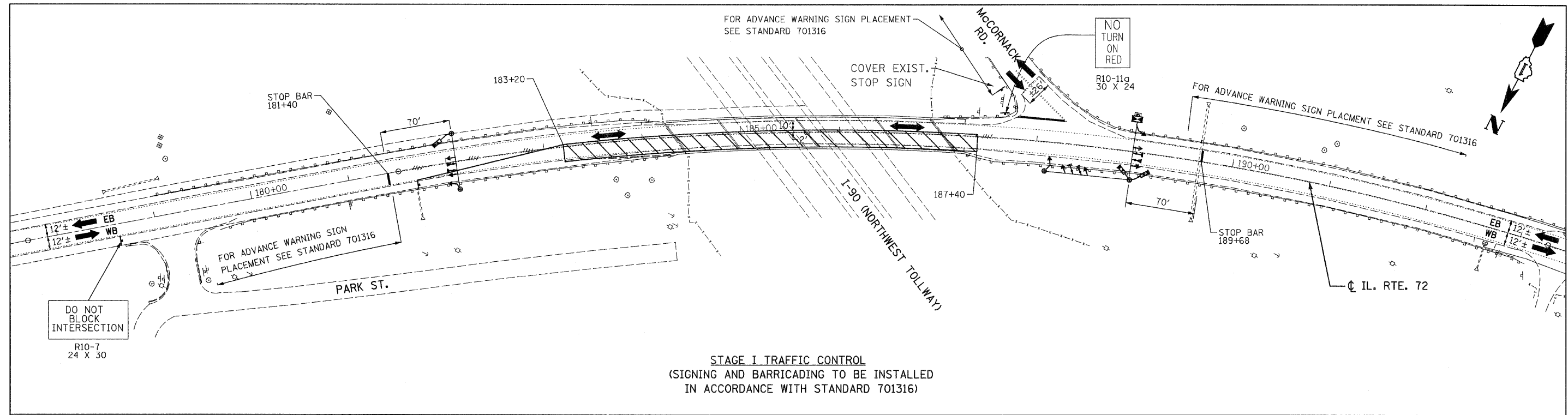

**TRAFFIC CONTROL AND STAGING LEGEND**

- WORK ZONE
- SIGN
- TRAFFIC SIGNAL
- PAVEMENT MARKING REMOVAL
- DIRECTION OF TRAFFIC

NOTES:  
 1. SEE STANDARD 701316 FOR ALL NOTES, DETAILS, AND SIGNS AND BARRICADE PLACEMENT.  
 2. TEMPORARY RUMBLE STRIPS ARE NOT REQUIRED.

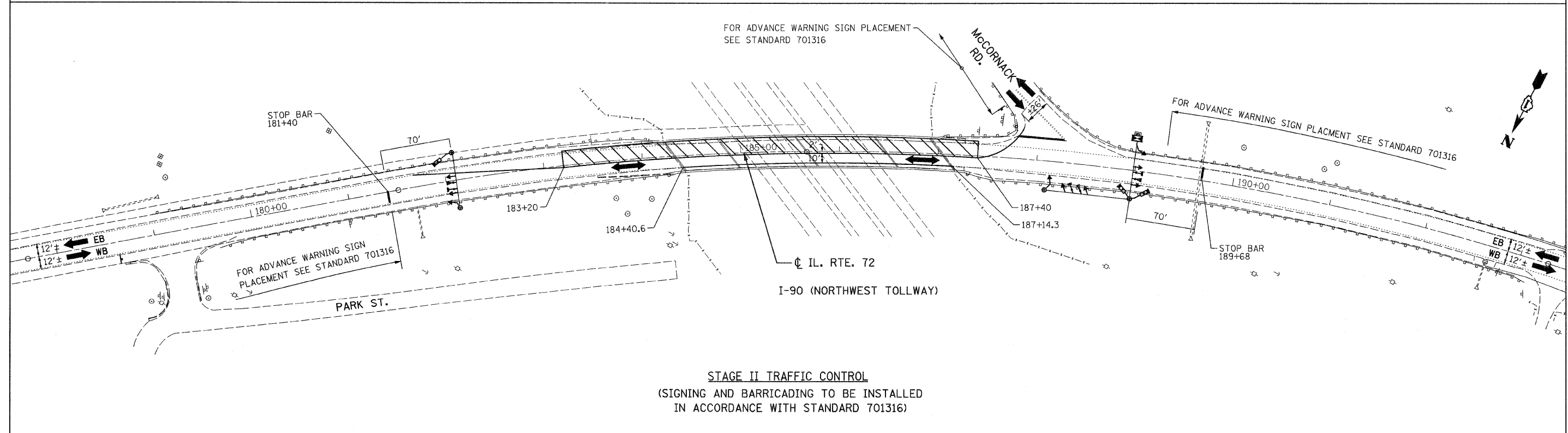



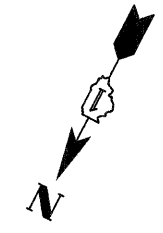

**TEMPORARY LIGHTING LEGEND**

<p>EXISTING</p> <p>— A —</p> <p>⊕</p> <p>⊕</p> <p>⊕</p> <p>⊕</p> <p>⊕</p> <p>⊕</p>	<p>PROPOSED</p> <p>⊕</p> <p>⊕</p> <p>— AC —</p> <p>⊕</p> <p>⊕</p> <p>⊕</p> <p>⊕</p> <p>⊕</p> <p>⊕</p>	<p>400W, 120V, MCIII HPS. WITH PHOTO CELL 15' MA, 50 MH ON WOOD POLE,</p> <p>AERIAL LINE (COMED/TELEPHONE)</p> <p>WOODEN POLE (60' OR 80' WOODEN CLASS 3 OR 4) WITH TEMPORARY LIGHTING UNIT</p> <p>WOOD POLE (80' CLASS 4) FOR TEMPORARY LIGHTING</p> <p>AERIAL ELECTRIC CABLE WITH MESSENGER WIRE</p> <p>5/8 " x 10' GROUND ROD</p> <p>COMBINATION LIGHTING AND TRAFFIC, POLE MOUNTED ELECTRICAL SERVICE BOX</p> <p>COMED POWER POLE</p> <p>TELEPHONE SPLICE BOX</p>
--	---	---

**TEMPORARY TRAFFIC SIGNAL LEGEND**

<p>PROPOSED</p> <p>←</p> <p>TSC</p> <p>— TS —</p> <p>⊕</p> <p>⊕</p> <p>↔</p>	<p>TEMPORARY TRAFFIC SIGNAL HEAD</p> <p>TEMPORARY TRAFFIC SIGNAL CONTROLLER CABINET</p> <p>TEMPORARY TRAFFIC SIGNAL SPAN WIRE, TETHER WIRE, AND CABLE</p> <p>VIDEO DETECTOR SENSOR</p> <p>TEMPORARY TRAFFIC SIGNAL WOOD POLE, CLASS 5 OR BETTER, 45 FOOT (13.7m) MINIMUM (TO BE INSTALLED 15' FROM EDGE OF TRAVELED WAY, BEHIND GUARDRAIL)</p> <p>DIRECTION OF TRAFFIC FLOW</p>
--	---

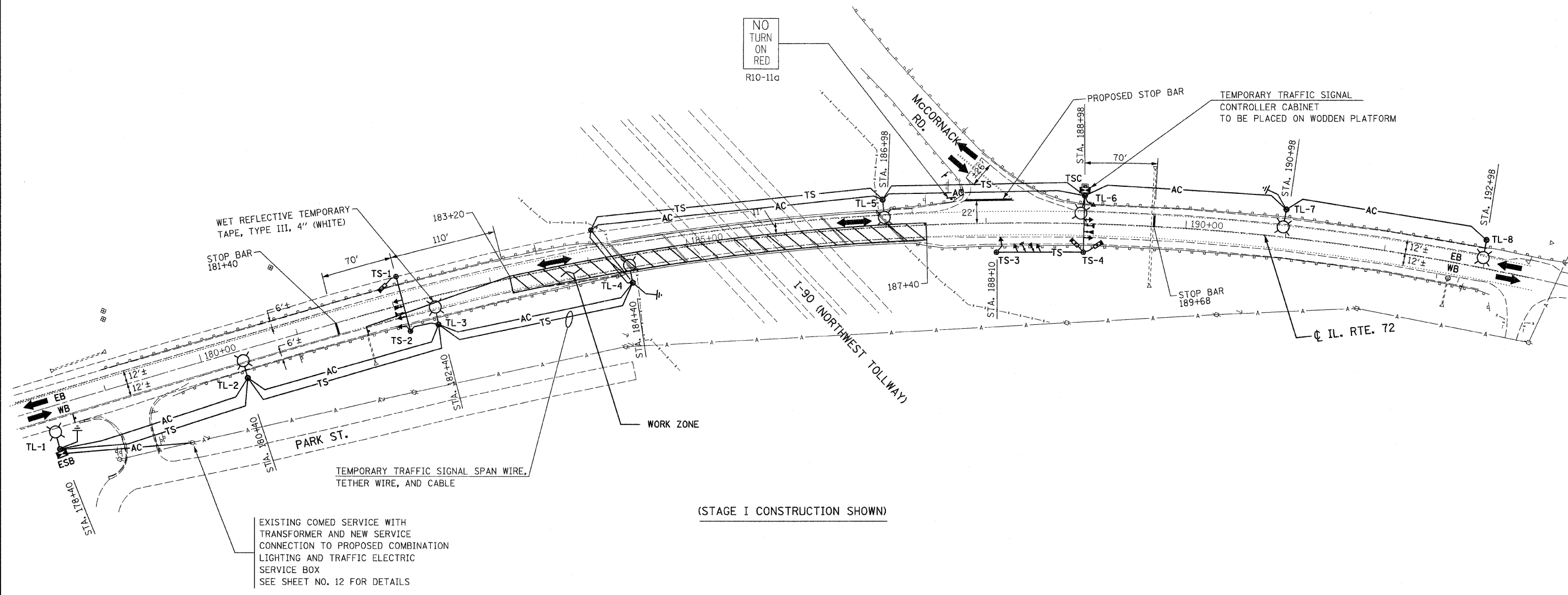

SEQUENCE OF OPERATION

MOVEMENT	McCORNACK RD.		McCORNACK RD.		McCORNACK RD.		McCORNACK RD.		F L A S H	
	IL. RTE.72		IL. RTE.72		IL. RTE.72		IL. RTE.72			
PHASE	2		6		8					
INTERVAL	1	2A	2B	3	4A	4B	5	6A	6B	
CHANGE TO		6, 8			2, 8			2, 6		
IL. RTE.72 SIGNAL (WEST BOUND)	G	Y	R	R	R	R	R	R	R	R
IL. RTE.72 SIGNAL (EAST BOUND)	R	R	R	G	Y	R	R	R	R	R
McCORNACK RD. SIGNAL (EAST BOUND & WEST BOUND)	R	R	R	R	R	R	G	Y	R	R

TEMPORARY TRAFFIC SIGNAL BILL OF MATERIALS

DESCRIPTION	UNIT	QUANTITY
TEMPORARY BRIDGE TRAFFIC SIGNAL INSTALLATION	EACH	1

TEMPORARY CABLE DIAGRAM LEGEND

- PROPOSED
- R TEMPORARY TRAFFIC SIGNAL SECTION OR PEDESTRIAN SIGNAL SECTION 12" (300 mm)
  - TSC X TEMPORARY TRAFFIC SIGNAL CONTROLLER
  - ESD X ELECTRIC SERVICE DISCONNECT, LIGHTING AND TRAFFIC SIGNAL
  - ⊕ EXISTING COMED ELECTRIC SERVICE TRANSFORMER
  - 5 INDICATES NUMBER OF CONDUCTORS IN CABLE. ALL CONDUCTORS TO BE NUMBER 14 AWG WIRE UNLESS OTHERWISE NOTED.
  - V VIDEO DETECTOR SENSOR
  - CONFIRMATION BEACON
  - ▲ EMERGENCY VEHICLE LIGHT DETECTOR
  - UPS UNINTERRUPTIBLE POWER SUPPLY
  - R  
Y  
G TEMPORARY TRAFFIC SIGNAL HEAD (L.E.D.)

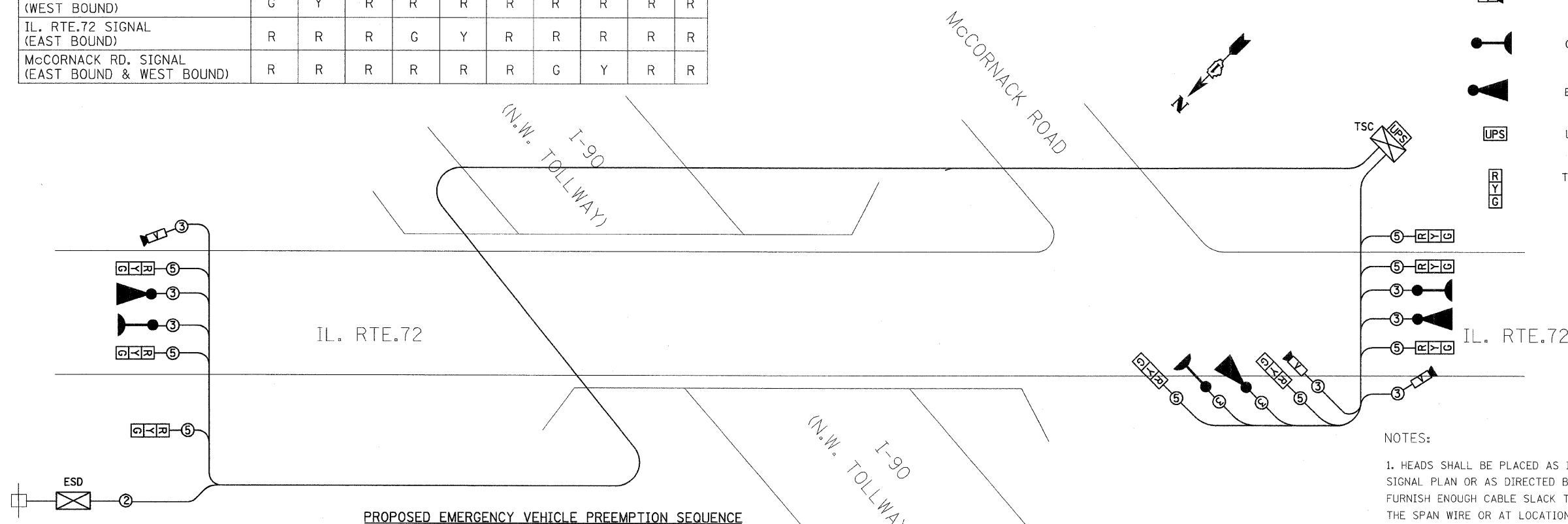

- NOTES:
- HEADS SHALL BE PLACED AS INDICATED ON THE TEMPORARY TRAFFIC SIGNAL PLAN OR AS DIRECTED BY THE ENGINEER. THE CONTRACTOR SHALL FURNISH ENOUGH CABLE SLACK TO RELOCATE HEADS TO ANY POSITION ON THE SPAN WIRE OR AT LOCATIONS ILLUSTRATED ON THE PLANS FOR CONSTRUCTION STAGING.
  - THE PROPOSED TEMPORARY BRIDGE TRAFFIC SIGNAL SHALL BE ACTIVATED, TESTED OPERATIONAL AND APPROVED BY THE ENGINEER BEFORE ANY PERMANENT LANE CLOSURES.
  - ALL LABOR AND MATERIALS TO COMPLY WITH THESE REQUIREMENTS SHALL BE CONSIDERED INCLUDED IN THE BID PRICE OF TEMPORARY BRIDGE TRAFFIC SIGNAL INSTALLTION.
  - TEMPORARY TRAFFIC SIGNAL TO SHARE TEMPORARY ELECTRIC LIGHTING WOOD POLES TL-1 THROUGH TL-6.

LEGEND

- \* SINGLE ENTRY PHASE
- \* NUMBER REFERRING TO ASSOCIATED PHASE

PROPOSED EMERGENCY VEHICLE PREEMPTORS			
PRIORITY LANE INTERVAL	3	4	5
MOVEMENT	→	←	↓

I.D.O.T. TRAFFIC SIGNAL INSTALLATION ELECTRICAL SERVICE REQUIREMENTS					TOTAL WATTAGE
TYPE	NO. LAMPS	WATTAGE		%OPERATION	
SIGNAL (RED)	8	INCAND.	17	0.50	68
		LED	25	0.25	
		(YELLOW)	8	135	
(GREEN)	8	135	15	0.25	30
ARROW		135	12	0.10	
PED. SIGNAL CONTROLLER	1	90	25	1.00	
ILLUM. SIGN		100	100	1.00	100.00
		84		0.05	
EVP	1		25	1.00	25
V.D.S.	1		25	1.00	25
FLASHER				0.50	--
TOTAL =					298

ENERGY COSTS TO BE IDOT DISTRICT 1 TOTAL = 298  
 BILLED TO ADDRESS: 201 W.CENTER COURT  
 SCHAUMBURG, IL 60196-1096

ENERGY SUPPLY CONTACT: KRISTI BUTTS  
 PHONE: (847) 608-2331  
 COMPANY: COM. ED.

FILE NAME = 68072 signal 2.dgn  
 PLOT DATE = 1/15/2009

**CHRISTIAN-ROGE & ASSOCIATES, INC.**  
 ENGINEERS-PLANNERS-SURVEYORS  
 211 WEST WACKER DRIVE  
 CHICAGO, ILLINOIS 60606  
 PHONE: (312)372-2023 FAX: (312)372-5274

DESIGNED - M.A.  
 DRAWN - M.A.  
 CHECKED - S.J.P.  
 DATE - JANUARY 15, 2009

REVISED -  
 REVISED -  
 REVISED -  
 REVISED -

STATE OF ILLINOIS  
 DEPARTMENT OF TRANSPORTATION

TEMPORARY CABLE PLAN AND PHASE DESIGNATION DIAGRAM  
 IL. 72

SCALE: NONE SHEET NO. 2 OF 2 SHEETS STA. 179+00 TO STA. 194+00

F.A.P. RTE.	SECTION	COUNTY	TOTAL SHEETS	SHEET NO.
341	N-4-C-1	KANE	32	10
CONTRACT NO. 60D72				
FED. ROAD DIST. NO. 1 ILLINOIS FED. AID PROJECT				

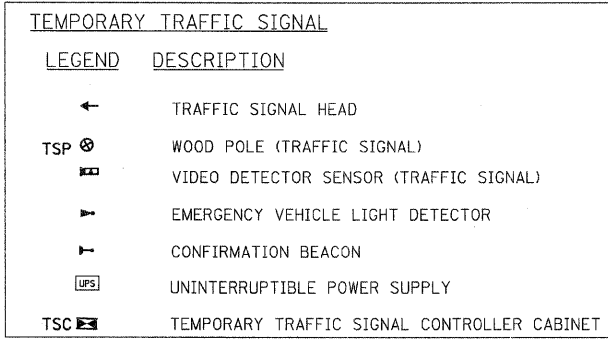
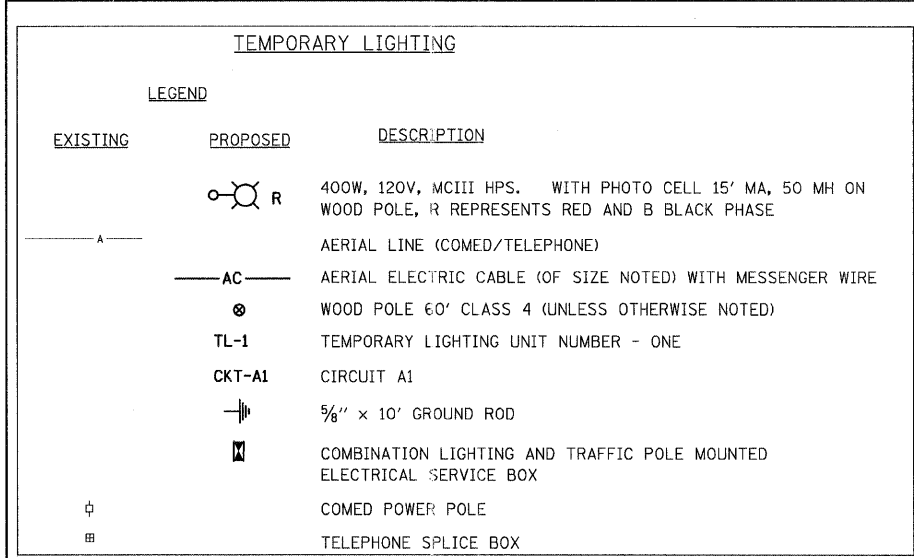

### BILL OF MATERIALS - TEMPORARY LIGHTING

ITEM DESCRIPTION	UNIT	QUANTITY
ELECTRIC SERVICE INSTALLATION	EACH	1
ELECTRIC UTILITY SERVICE CONNECTION	L SUM	1
AERIAL CABLE, 3-1/C NO. 2 WITH MESSENGER WIRE	FOOT	1,608
LUMINAIRE, SODIUM VAPOR, HORIZONTAL MOUNT, PHOTO-CELL CONTROL, 400 WATT	EACH	8
LIGHT POLE, WOOD, 60 FOOT, CLASS 4, WITH 15FT MAST ARM	EACH	8
LIGHT POLE, WOOD, 80 FOOT, CLASS 3, WITH 15FT MAST ARM	EACH	2
LIGHT POLE, WOOD, 80 FOOT, CLASS 4	EACH	1
REMOVAL OF TEMPORARY LIGHTING UNITS	EACH	8
REMOVE TEMPORARY WOOD POLE	EACH	1
MAINTENANCE OF LIGHTING SYSTEM	CAL MO	6
COMBINATION POLE MOUNTED ELECTRICAL SERVICE BOX	EACH	1
GROUND ROD, 5/8" DIA. x 10 FT.	EACH	2
ELECTRIC SERVICE DISCONNECT, LIGHTING AND TRAFFIC SIGNAL	EACH	1

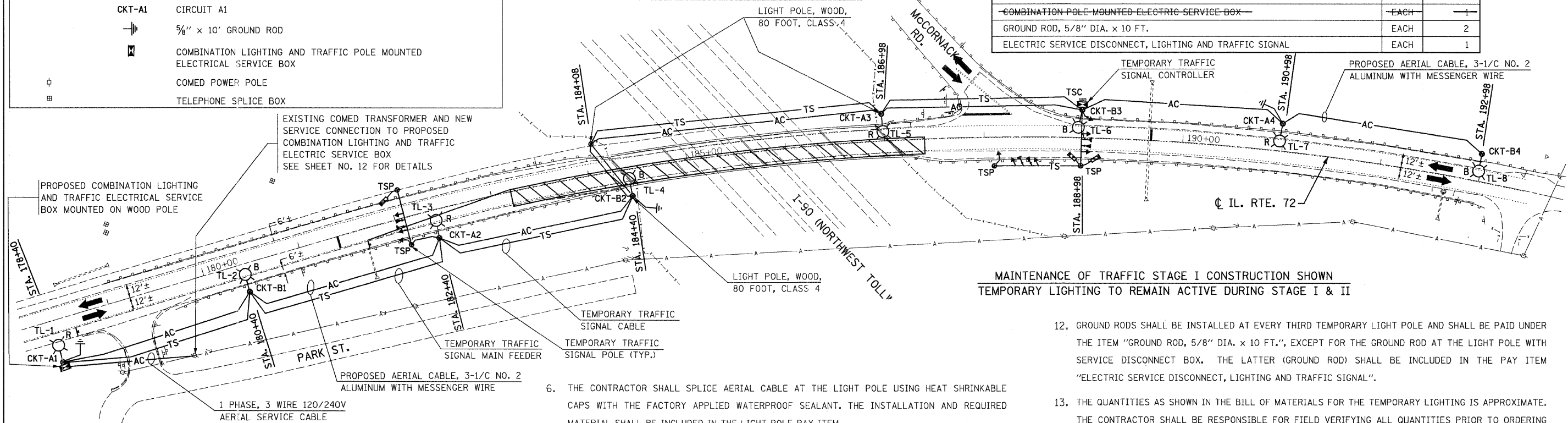

**MAINTENANCE OF TRAFFIC STAGE I CONSTRUCTION SHOWN  
TEMPORARY LIGHTING TO REMAIN ACTIVE DURING STAGE I & II**

**NOTES:**

- THE MATERIALS AND INSTALLATION METHODS SHALL COMPLY WITH THE LATEST CODES, STANDARDS AND ORDINANCES OF FEDERAL, STATE AND LOCAL GOVERNING BODIES HAVING JURISDICTION. ALL WORKS SHOWN ON THE PLANS AND DESCRIBED ELSEWHERE SHALL ALSO CONFORM TO THE LATEST NATIONAL ELECTRICAL CODE.
- ALL MATERIAL PARTS OF THE LIGHT POLES SHALL BE GROUNDED AND BONDED CONFORMING TO NEC ARTICLE 250. THE EQUIPMENT GROUND SHALL BE CONTINUOUS AND CONNECTED UP TO THE ELECTRICAL SYSTEM GROUND. THIS WORK SHALL BE INCLUDED IN THE LIGHT POLE PAY ITEM.
- ALL TEMPORARY LIGHT POLES FOR THIS PROJECT SHALL BE LOCATED BEHIND EXISTING GUARDRAIL AND SHALL BE SET 15' BEHIND THE EDGE OF THE TRAVELED WAY, EXCEPT FOR POLE NO. TL-1 WHICH SHALL BE SET 30' BEHIND THE EDGE OF THE TRAVELED WAY. FINAL LOCATIONS OF ALL LIGHT POLES SHALL BE DIRECTED AND APPROVED BY THE ENGINEER.
- THE TEMPORARY LIGHT POLES SHALL HAVE IDENTIFICATION NUMBERS AS SHOWN ON THE PLANS.
- THE CONTRACTOR SHALL BE RESPONSIBLE FOR ANY DAMAGE TO THE LIGHTING AND TRAFFIC SIGNAL INSTALLATION. THE CONTRACTOR SHALL NOT INSTALL DAMAGED EQUIPMENT OR DEFECTIVE DEVICES, INSTEAD THE CONTRACTOR SHALL REPLACE IT WITH NEW ONES AT NO COST TO IDOT AND/OR AS DIRECTED BY THE ENGINEER.

- THE CONTRACTOR SHALL SPLICE AERIAL CABLE AT THE LIGHT POLE USING HEAT SHRINKABLE CAPS WITH THE FACTORY APPLIED WATERPROOF SEALANT. THE INSTALLATION AND REQUIRED MATERIAL SHALL BE INCLUDED IN THE LIGHT POLE PAY ITEM.
- THE CONTRACTOR SHALL FOLLOW THE CONSTRUCTION AND STAGING AS SHOWN ON THE PLANS OR AS DIRECTED BY THE ENGINEER. FURTHERMORE, THE CONTRACTOR SHALL COORDINATE ALL SUCH ACTIVITIES BEING DONE IN THE SAME AREA BY THE UTILITY COMPANIES OR OTHER CONTRACTORS AND SETUP COORDINATION MEETINGS IF NECESSARY WITHOUT ANY ADDITIONAL FINANCIAL COMPENSATION.
- THE PROPOSED TEMPORARY LIGHTING SHALL BE COMPLETED, TESTED, OPERATIONAL AND VERIFIED BY IDOT BEFORE STAGE I TRAFFIC CONTROL IS IN PLACE. THE CONTRACTOR SHALL SUBMIT A STAGING SCHEDULE IDENTIFYING THE STARTING AND COMPLETION DATES PRIOR TO THE COMMENCEMENT OF WORK FOR PROCUREMENT, INSTALLATION AND/OR REMOVAL OF EXISTING MATERIAL AND/OR EQUIPMENT.
- ALL AREAS DISTURBED UNDER THIS CONTRACT SHALL BE RESTORED TO THE ORIGINAL CONDITION OR BETTER TO THE SATISFACTION OF THE ENGINEER.
- LIGHTING SHALL BE KEPT OPERATIONAL AND ACTIVE FROM ONE HOUR BEFORE SUNSET TO ONE HOUR AFTER SUNRISE. AS PER "NATIONAL ELECTRIC CODE", OVERHEAD SPANS OF AERIAL CABLE AND MESSENGER WIRE MUST HAVE A VERTICAL CLEARANCE OF 18' MINIMUM ABOVE THE GROUND AT ALL TIMES AND AT ALL LOCATIONS ON THE PROJECT.
- THE CONTRACTOR SHALL INSTALL ALL EQUIPMENT SO AS TO COMPLY WITH REQUIRED ELECTRICAL CLEARANCES PER NATIONAL ELECTRICAL CODE (NEC) SECTION 225-18, NATIONAL ELECTRICAL SAFETY CODE AND COMED REQUIREMENTS.

- GROUND RODS SHALL BE INSTALLED AT EVERY THIRD TEMPORARY LIGHT POLE AND SHALL BE PAID UNDER THE ITEM "GROUND ROD, 5/8" DIA. x 10 FT.", EXCEPT FOR THE GROUND ROD AT THE LIGHT POLE WITH SERVICE DISCONNECT BOX. THE LATTER (GROUND ROD) SHALL BE INCLUDED IN THE PAY ITEM "ELECTRIC SERVICE DISCONNECT, LIGHTING AND TRAFFIC SIGNAL".
- THE QUANTITIES AS SHOWN IN THE BILL OF MATERIALS FOR THE TEMPORARY LIGHTING IS APPROXIMATE. THE CONTRACTOR SHALL BE RESPONSIBLE FOR FIELD VERIFYING ALL QUANTITIES PRIOR TO ORDERING ANY MATERIALS OR EQUIPMENT.
- THE TEMPORARY LIGHTING SHALL USE AERIAL CABLES AS SHOWN ON THE PLANS. HOWEVER, THE UNDERGROUND NEW ELECTRICAL INSTALLATION, IF ANY, SHALL BE AT A MINIMUM 30 INCHES BELOW GRADE AND SHALL HAVE ELECTRICAL WARNING TAPE CONFORMING TO IDOT STANDARDS.
- THE CONTRACTOR SHALL NOTIFY THE UTILITY COMPANY AS SOON AS POSSIBLE CONCERNING PENDING ELECTRICAL SERVICE INSTALLATION AND CONNECTION TO ENSURE THE AVAILABILITY OF ELECTRICAL POWER SUPPLY IN A TIMELY MANNER.
- THE CONTRACTOR MAY MODIFY ELECTRICAL IDOT STANDARD DETAILS AS NECESSARY TO SUIT SPECIFIC SITE CONDITIONS. HOWEVER, THE CONTRACTOR SHALL OBTAIN THE ENGINEER'S APPROVAL PRIOR TO THE INSTALLATION.
- THE REMOVAL OF TEMPORARY LIGHTING SHALL INCLUDE, BUT NOT LIMITED TO: ALL WOODEN POLES, LUMINAIRES WITH MAST ARMS, MESSENGER WIRES / CABLES, COM ED SERVICE CABLES, CONDUITS AND/OR SERVICE BOXES AND HAULING AWAY OF THESE ITEMS FROM THE PROJECT SITE. ALL TEMPORARY LIGHTING EQUIPMENT AND MATERIAL REMOVED FROM THE PROJECT SHALL BECOME THE PROPERTY OF THE CONTRACTOR.
- THE EXACT LOCATION OF EXISTING POWER POLES WITH COMED TRANSFORMERS TO BE DETERMINED IN THE FIELD. COMED CONTACT INFORMATION FOR THIS PROJECT IS AS FOLLOWS:  
FIELD REPRESENTATIVE: KRISTI BUTTS (847) 608-2331

ACCOUNT NO. 31270-17013, TRANSFORMER NO. 42123404

FILE NAME = 62072\_lght1.dgn  
PLOT DATE = 1/15/2009

**CHRISTIAN-ROGE & ASSOCIATES, INC.**  
ENGINEERS-PLANNERS-SURVEYORS  
211 WEST WACKER DRIVE  
CHICAGO, ILLINOIS 60606  
PHONE: (312)372-2023 FAX: (312)372-5274

DESIGNED - M.A.	REVISED -
DRAWN - M.A.	REVISED -
CHECKED - R.S.	REVISED -
DATE - JANUARY 15, 2009	REVISED -

**STATE OF ILLINOIS  
DEPARTMENT OF TRANSPORTATION**

**TEMPORARY LIGHTING PLAN  
IL 72**

SCALE: 1" = 50' SHEET NO. 1 OF 2 SHEETS STA. 179+00 TO STA. 194+00

F.A.P. RTE.	SECTION	COUNTY	TOTAL SHEETS	SHEET NO.
341	N-4-C-1	KANE	32	11
CONTRACT NO. 60D72				
FED. ROAD DIST. NO. 1 ILLINOIS FED. AID PROJECT				



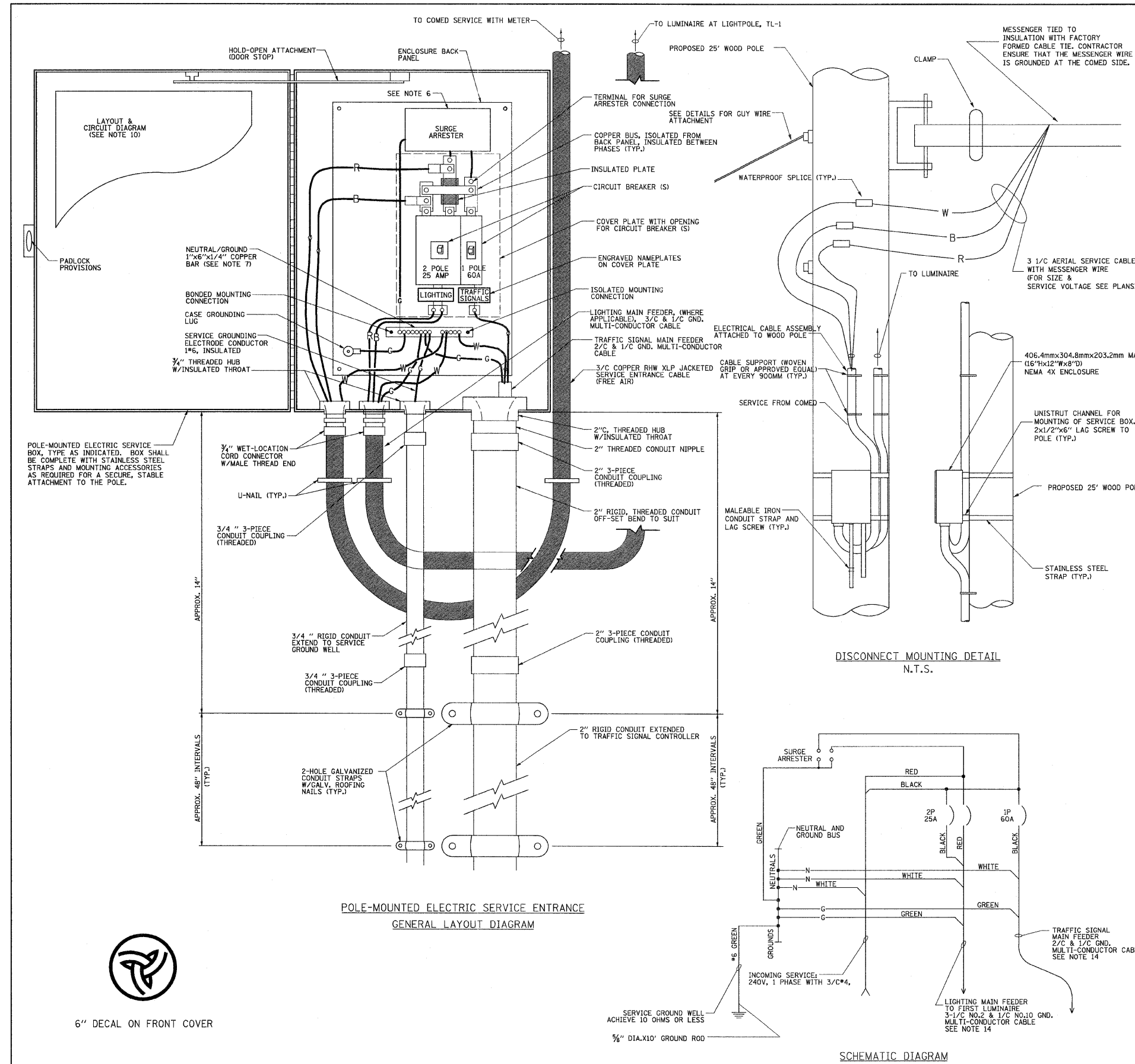

**NOTES**

- ELECTRIC SERVICE SHALL BE OF THE VOLTAGE INDICATED OR DESIGNATED BY THE ENGINEER, AND SERVICE DROP CABLE SHALL BE COMPATIBLE WITH THE SERVICE ACCORDINGLY. SOME INSTALLATIONS MAY CALL FOR SERVICE ENTRANCE EQUIPMENT SUITABLE FOR 3-WIRE SERVICE EVEN THOUGH INITIALLY WIRED FOR 2-WIRE SERVICE.
- THE POLE-MOUNTED ELECTRIC SERVICE BOX DETAIL DEPICTS THE BASIC CONSTRUCTION OF THE EQUIPMENT. SLIGHT MODIFICATIONS APPLY FOR DIFFERING SERVICES AND APPLICATIONS AS FOLLOWS:  
 FULLY EQUIPPED FOR 240/120V. 3W SERVICE, COMPLETE WITH LIGHTING MAIN BREAKER  
 FULLY EQUIPPED FOR 240/120V. 3W SERVICE, BLANK COVER IN LIEU OF LIGHTING MAIN BREAKER  
 EQUIPPED FOR 120V. SERVICE, COMPLETE WITH 1P, 60A. TRAFFIC SIGNALS MAIN BREAKER  
 EQUIPPED FOR 120V. SERVICE, COMPLETE WITH 1P, 40A. TRAFFIC SURVEILLANCE MAIN BREAKER
- THE ELECTRIC SERVICE EQUIPMENT ASSEMBLY SHALL BE UL LISTED AS SUITABLE FOR USE AS SERVICE ENTRANCE EQUIPMENT.
- THE ELECTRIC SERVICE EQUIPMENT ENCLOSURE SHALL BE NEMA 4X STAINLESS STEEL, NOMINALLY 12"W X 16"H X 8"D, WITH A PIANO-HINGED DOOR, STEEL BACK PANEL, FAST-ACTING STAINLESS STEEL ENCLOSURE CLAMPS, PADLOCK PROVISIONS AND DOOR STOP, HOFFMAN CATALOG NO. A-16H1208SS6LP/A-16, P12/A-DSTOPK/C-PMK12, OR APPROVED EQUAL.
- CIRCUIT BREAKERS SHALL BE THERMAL MAGNETIC BOLT-ON TYPE WITH A MINIMUM INTERRUPTING CAPACITY OF 25,000 SYMMETRICAL AMPERES AT 120 VOLTS. THEY SHALL BE LOCKABLE IN THE "OFF" POSITION FOR COMPLIANCE WITH OSHA LOCK-OUT/TAG-OUT REQUIREMENTS. HANDLES SHALL BE TRIP FREE.
- THE SURGE PROTECTOR SHALL BE SUITABLE FOR 240/120 VOLT SINGLE PHASE 60HZ AC ELECTRICAL SERVICE, WITH A SURGE ENERGY CAPABILITY OF 2160 JOULES OR BETTER AT 8/20 MICRO-SECONDS, RATED -40 TO 60 DEGREE C., WITH LED OPERATING INDICATORS, AND SHALL BE UL LISTED PER UL 1449, CUTLER-HAMMER CMOV230L065XST OR APPROVED EQUAL.
- BUS BARS, CONNECTORS, AND LUGS SHALL BE COPPER, INSULATED AND ISOLATED, AND CONFIGURED TO PREVENT SHORTED CONDITIONS FROM TIGHTENING TERMINATIONS, ETC. THE OVERALL BUS SECTION SHALL BE CONFIGURED BEHIND AN INSULATING BARRIER SHIELD WHICH IS REMOVABLE FOR ACCESS TO CONNECTIONS, OR THE ASSEMBLY SHALL BE A MANUFACTURED SPECIALTY PANELBOARD, CUTLER-HAMMER PRL2A OR APPROVED EQUAL.
- THE COMBINATION GROUND AND NEUTRAL BAR SHALL BE CONFIGURED WITH SEPARATE GROUND AND NEUTRAL SECTIONS AND SPARE TERMINALS AS INDICATED. THE HEADS OF GROUND SCREWS SHALL BE PAINTED GREEN. THE HEADS OF NEUTRAL SCREWS SHALL BE PAINTED WHITE. THE SERVICE NEUTRAL AND SERVICE GROUNDING ELECTRODE CONDUCTOR SHALL BE TERMINATED ADJACENT TO EACH OTHER AT THE DIVIDE BETWEEN THE SECTIONS AND WIRING SHALL BE TERMINATED ONLY UPON THE APPROPRIATE SECTION.
- THE WIRING TERMINALS, INCLUDING THE GROUND/NEUTRAL BAR SHALL BE ARRANGED TO PROVIDE ADEQUATE ROOM FOR PERFORMING FIELD TERMINATIONS.
- A PLASTIC LAMINATED LAYOUT AND CIRCUIT DIAGRAM SHALL BE MECHANICALLY SECURED TO THE INTERIOR SIDE OF THE ENCLOSURE DOOR.
- A 2-COLOR ENGRAVED PLASTIC NAMEPLATE, ATTACHED WITH SCREWS, AND ENGRAVED AS INDICATED, SHALL BE PROVIDED FOR EACH MAIN BREAKER.
- LUGS AND CONNECTORS SHALL BE RATED FOR 75 C CONDUCTOR.
- THE EXACT MOUNTING HEIGHT OF THE BOX SHALL BE FIELD DETERMINED TO AVOID OBSTRUCTIONS AND PUBLIC ACCESS. TYPICAL HEIGHT SHALL BE APPROXIMATELY 10 FEET ABOVE GRADE.
- THE FEEDER CABLE (MATERIAL & INSTALLATION) FROM SERVICE DISCONNECT TO THE FIRST LIGHT POLE, AS SHOWN ON PLANS IS INCLUDED UNDER THE PAY ITEM "ELECTRIC SERVICE DISCONNECT, LIGHTING AND TRAFFIC SIGNAL".

CIRCUIT NO.	CIRCUIT BREAKER / POLES	UTILITY DESCRIPTION	LOAD <sup>1</sup> (WATTS)	CURRENT <sup>2</sup> (AMPERES)
A	25A / 2P	( 4 ) 400W HPS POLE NOS.TL-1, TL-3, TL-5, & TL-7	1,920	16.84
B		( 3 ) 400W HPS POLE NOS.TL-2, TL-4, & TL-6	1,440	12.63
TOTAL			3,360	29.47

**NOTE:**

- LOAD INCLUDES 20% BALLAST LOSSES FOR LUMINAIRES
- CURRENT CALCULATIONS INCLUDE A POWER FACTOR OF 0.95.



6" DECAL ON FRONT COVER

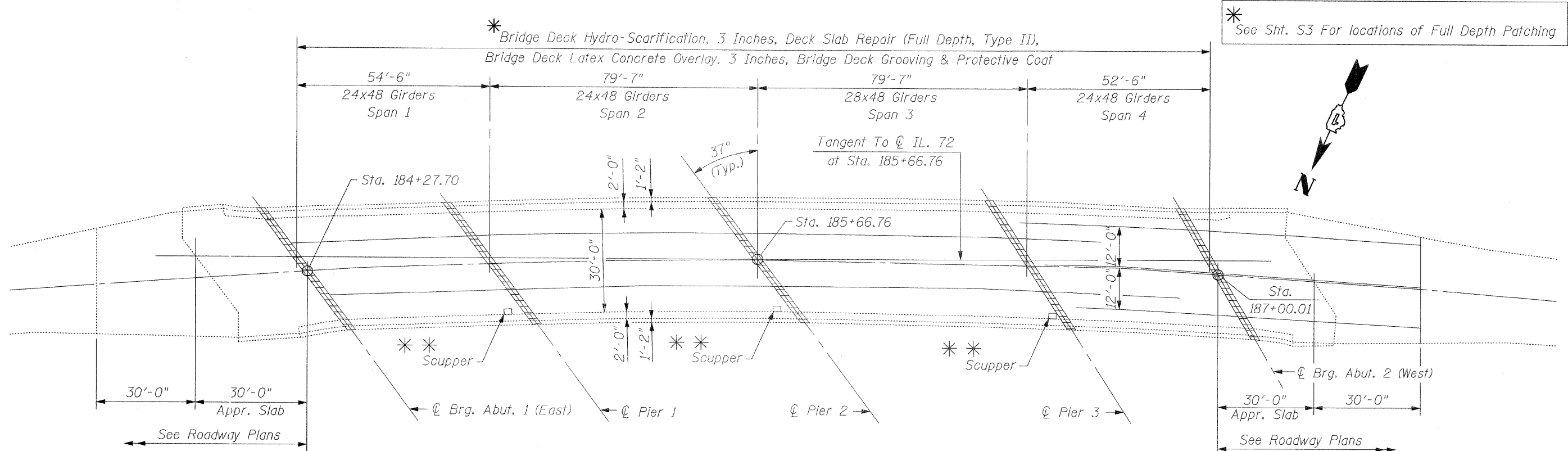

**EXISTING DECK PLAN**

**LEGEND:**

Reconstruct Transverse Expansion Joints, Place Preformed Joint Strip Seals

See Detail "A" on Sht. S3 for Scupper Details

**TOTAL BILL OF MATERIAL**

Item	Unit	Quantity
Concrete Removal	Cu. Yd.	65
Concrete Superstructure	Cu. Yd.	65
Reinforcement Bars, Epoxy Coated	Pound	15,190
Bridge Deck Hydro-Scarification, 3 Inches	Sq. Yd.	901
Bridge Deck Latex Concrete Overlay, 3 Inches	Sq. Yd.	901
Protective Coat	Sq. Yd.	961
Deck Slab Repair (Full Depth, Type II)	Sq. Yd.	44
Preformed Joint Strip Seal	Foot	225
Bridge Deck Grooving	Sq. Yd.	832
Bar Splicers	Each	122

**GENERAL NOTES:**

- Plan dimensions and details relative to existing plans are subject to routine variations. The Contractor shall field verify existing dimensions and details affecting new construction and make necessary approved adjustments prior to construction or ordering of materials. Such variations shall not be cause for additional compensation for a change in the scope of work, however, the Contractor will be paid for the quantity actually furnished based upon the unit price bid for the work.
- The Contractor should use extreme care during Concrete Removal as not to damage the Existing PPC I-Beams. Any damage caused shall be repaired at no cost to I.D.O.T.
- Areas of Deck Repairs shown are estimated. The Engineer shall show actual locations of Deck Repairs on As-Built Plans.
- Joint openings shall be adjusted according to Article 520.04 of The Standard Specifications when the Deck is poured at an ambient temperature other than 50° F.
- Reinforcement Bars shall conform to the requirements of ASTM A706 Grade 60. See Special Provisions.
- Reinforcement Bars designated (E) shall be Epoxy Coated.

**DESIGN STRESSES  
FIELD UNITS**

$f'_c = 3,500$  psi  
 $f_y = 60,000$  psi (Reinforcement)



CHRISTIAN-ROGE & ASSOCIATES, INC.  
 ENGINEERS / PLANNERS / SURVEYORS  
 211 W. WACKER DRIVE CHICAGO, IL. 60606  
 PHONE: (312)372-2023 FAX: (312)372-5274

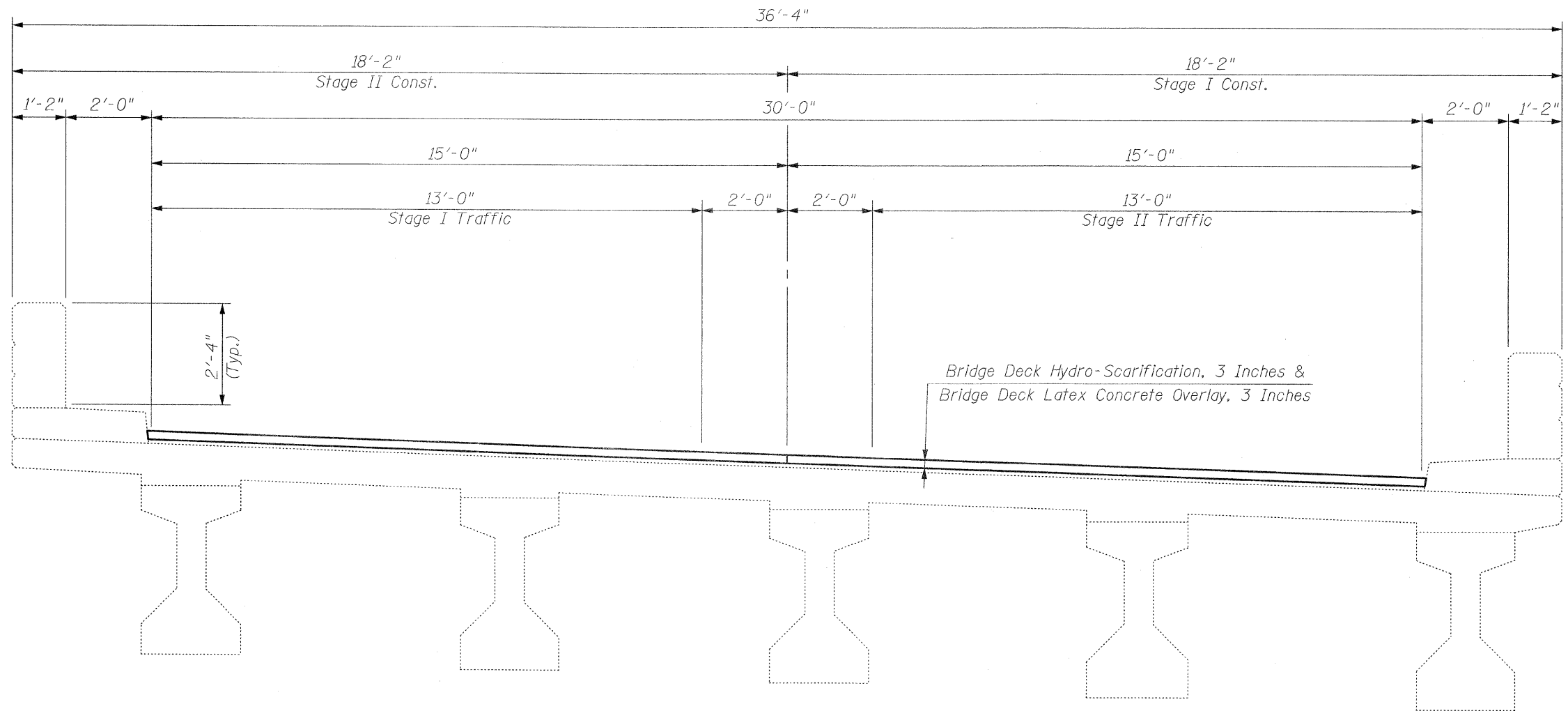

**EXISTING DECK CROSS SECTION**  
 (With Prop. Bridge Deck Latex Concrete Overlay, 3 Inches)  
 (Looking West)

**CR & A**  
 CHRISTIAN-ROGE & ASSOCIATES, INC.  
 ENGINEERS / PLANNERS / SURVEYORS  
 211 W. WACKER DRIVE CHICAGO, IL. 60606  
 PHONE: (312)372-2023 FAX: (312)372-5274

FILE NAME = deck cross section.sht	USER NAME = IDOT	DESIGNED - B.N.S.	REVISED -	<b>STATE OF ILLINOIS DEPARTMENT OF TRANSPORTATION</b>	<b>DECK CROSS SECTION IL. 72 OVER I-90</b>		<b>S.N. 045-0074</b>		F.A.P. RTE. 341	SECTION N-4-C-I	COUNTY KANE	TOTAL SHEETS 32	SHEET NO. 14
	PLOT SCALE = 50,0000 ' / IN.	CHECKED - B.N.S./J.C.N.	REVISED -						CONTRACT NO. 60D72				
	PLOT DATE = 1/15/2009	DATE - JANUARY 15, 2009	REVISED -						ILLINOIS FED. AID PROJECT				

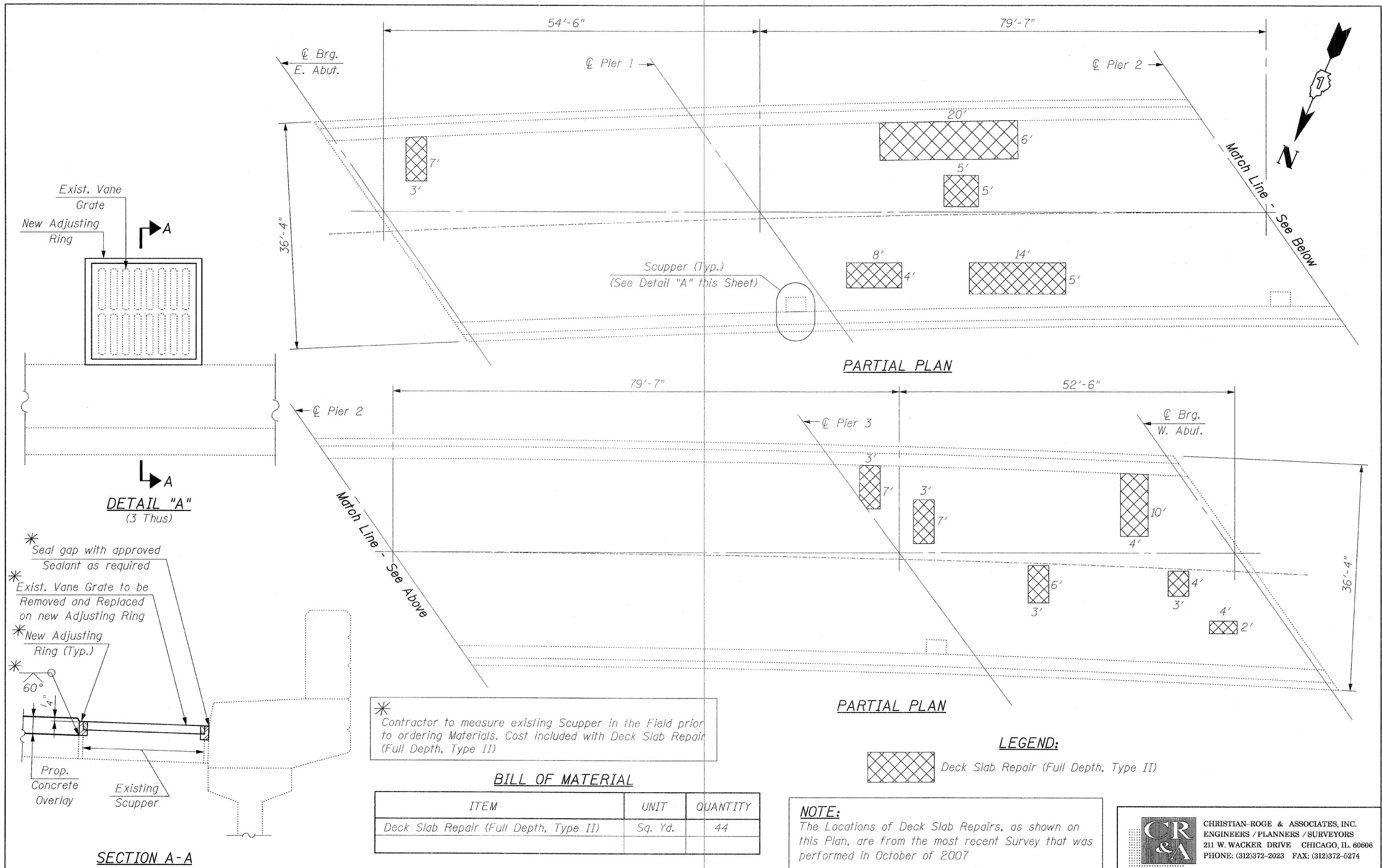

\* Seal gap with approved Sealant as required

\* Exist. Vane Grate to be Removed and Replaced on new Adjusting Ring

\* New Adjusting Ring (Typ.)

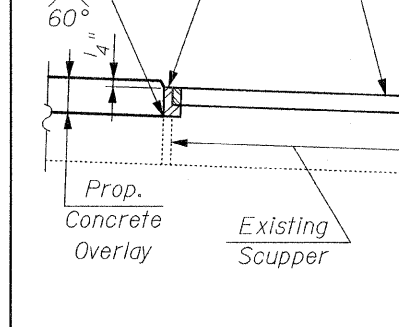

**SECTION A-A**

\* Contractor to measure existing Scupper in the Field prior to ordering Materials. Cost included with Deck Slab Repair (Full Depth, Type II)

**BILL OF MATERIAL**

ITEM	UNIT	QUANTITY
Deck Slab Repair (Full Depth, Type II)	Sq. Yd.	44

**LEGEND:**  
 Deck Slab Repair (Full Depth, Type II)

**NOTE:**  
 The Locations of Deck Slab Repairs, as shown on this Plan, are from the most recent Survey that was performed in October of 2007

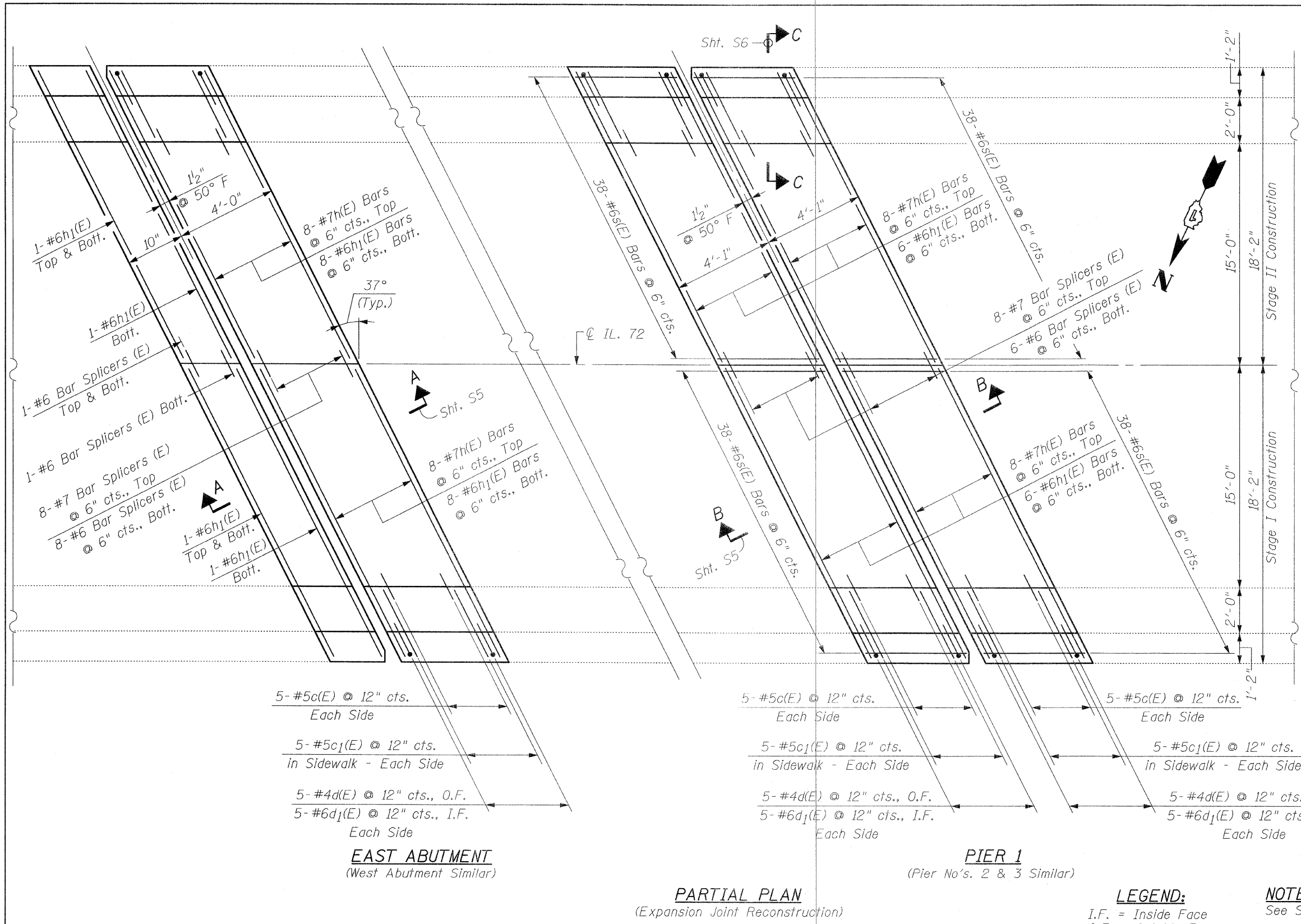

**BILL OF MATERIAL**

Bar	No.	Size	Length	Shape
c(E)	80	#5	2'-5"	
c1(E)	80	#5	3'-6"	—
d(E)	80	#4	4'-7"	L
d1(E)	80	#6	3'-9"	L
h(E)	128	#7	22'-2"	—
h1(E)	116	#6	22'-2"	—
s(E)	456	#6	6'-4"	
Reinforcement Bars, Epoxy Coated		Pound	15,190	
Concrete Removal		Cu. Yd.	65	
Concrete Superstructure		Cu. Yd.	65	
Bar Splicers		Each	122	
Protective Coat		Sq. Yd.	60	

\* Quantity is for Top & Inside Face of Reconstructed Parapets & Reconstructed Sidewalks

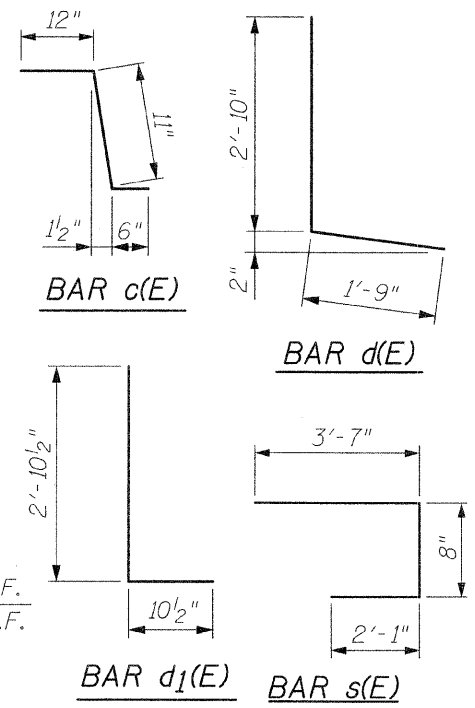

**LEGEND:**  
I.F. = Inside Face  
O.F. = Outside Face

**NOTE:**  
See Sht. S8 for Bar Splicer Assembly Details

**NOTE:**  
Work This Sheet With Sht's. S5 & S6

**CR & A**  
CHRISTIAN-ROGE & ASSOCIATES, INC.  
ENGINEERS / PLANNERS / SURVEYORS  
211 W. WACKER DRIVE CHICAGO, IL. 60606  
PHONE: (312)372-2023 FAX: (312)372-5274



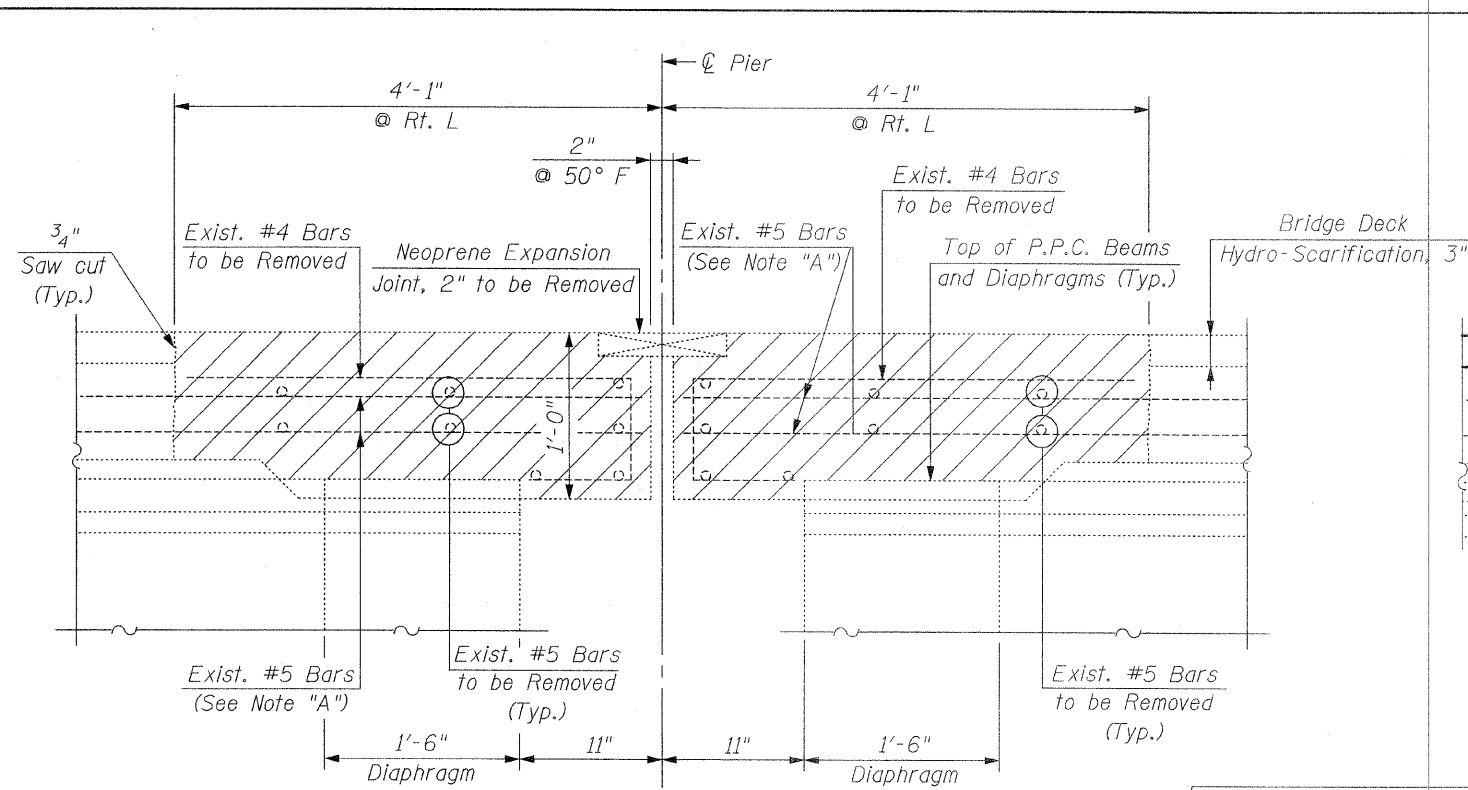

**SECTION B-B**

**EXPANSION JOINT AT PIERS**  
(Existing)

**NOTE:**  
Work This Sheet With Sht's. S4 & S6

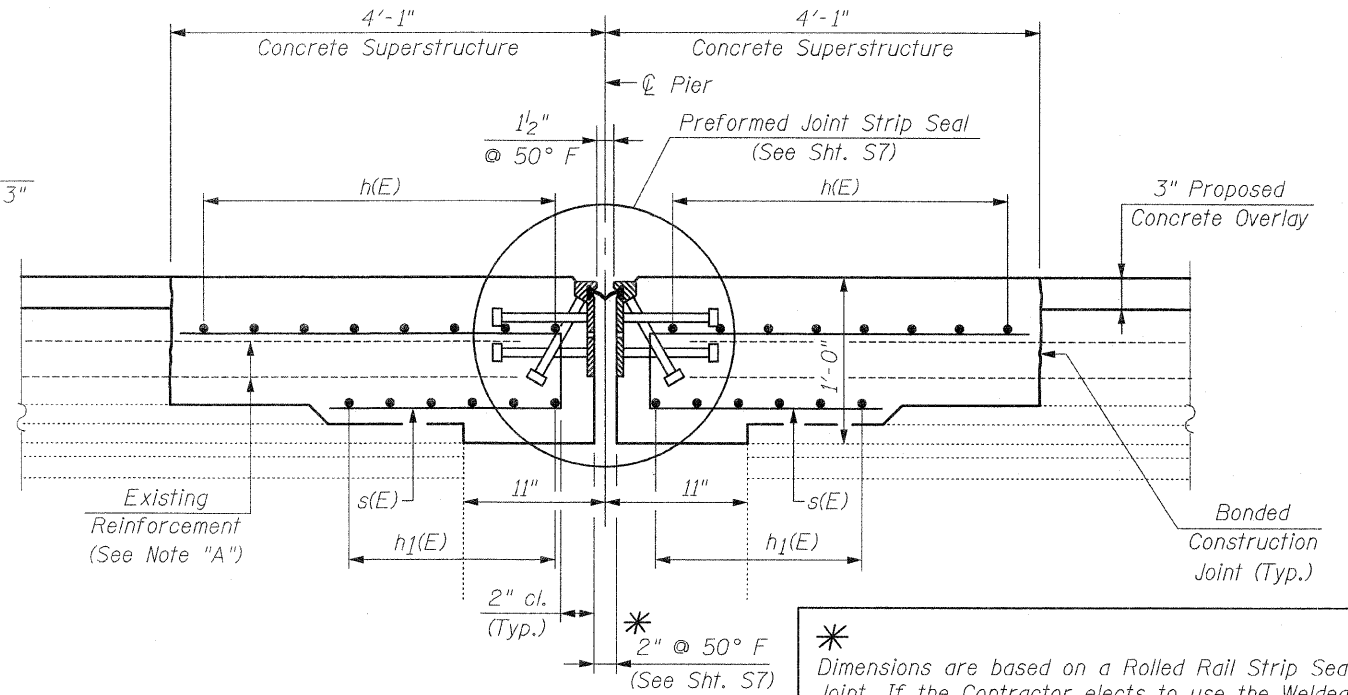

**SECTION B-B**

**EXPANSION JOINT AT PIERS**  
(Proposed)

\* Dimensions are based on a Rolled Rail Strip Seal Joint. If the Contractor elects to use the Welded Rail Strip Seal Joint, deck dimensions may require adjustments to match the details on Sht. S7

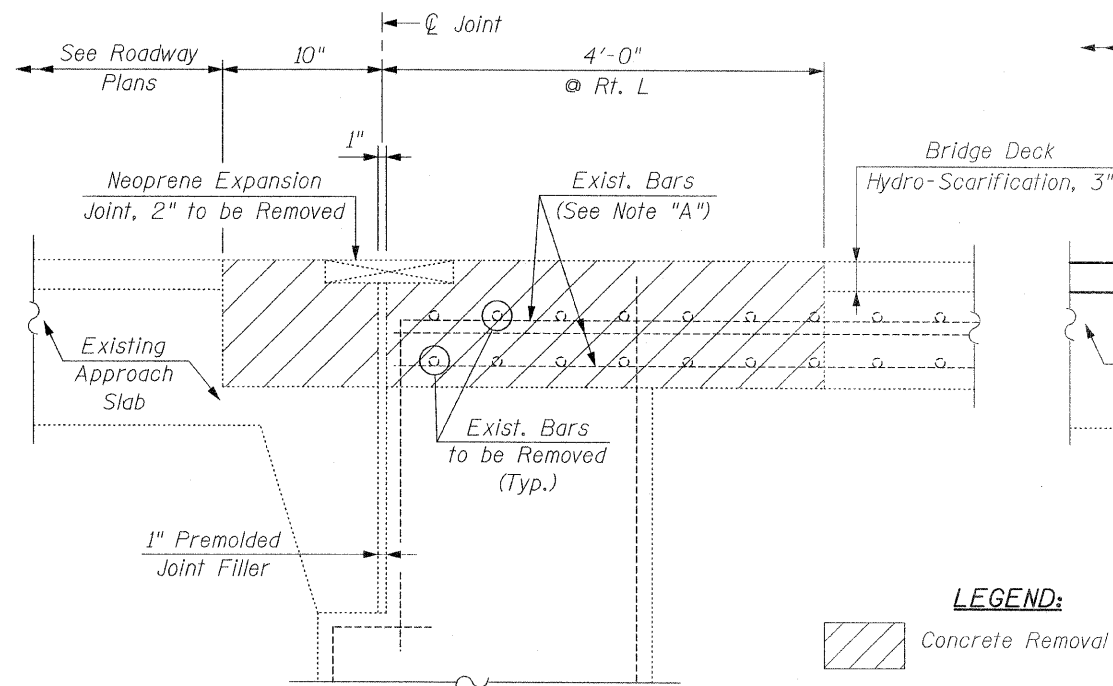

**SECTION A-A**

**EXPANSION JOINT AT ABUTMENTS**  
(Existing)

**LEGEND:**  
[Hatched Box] Concrete Removal

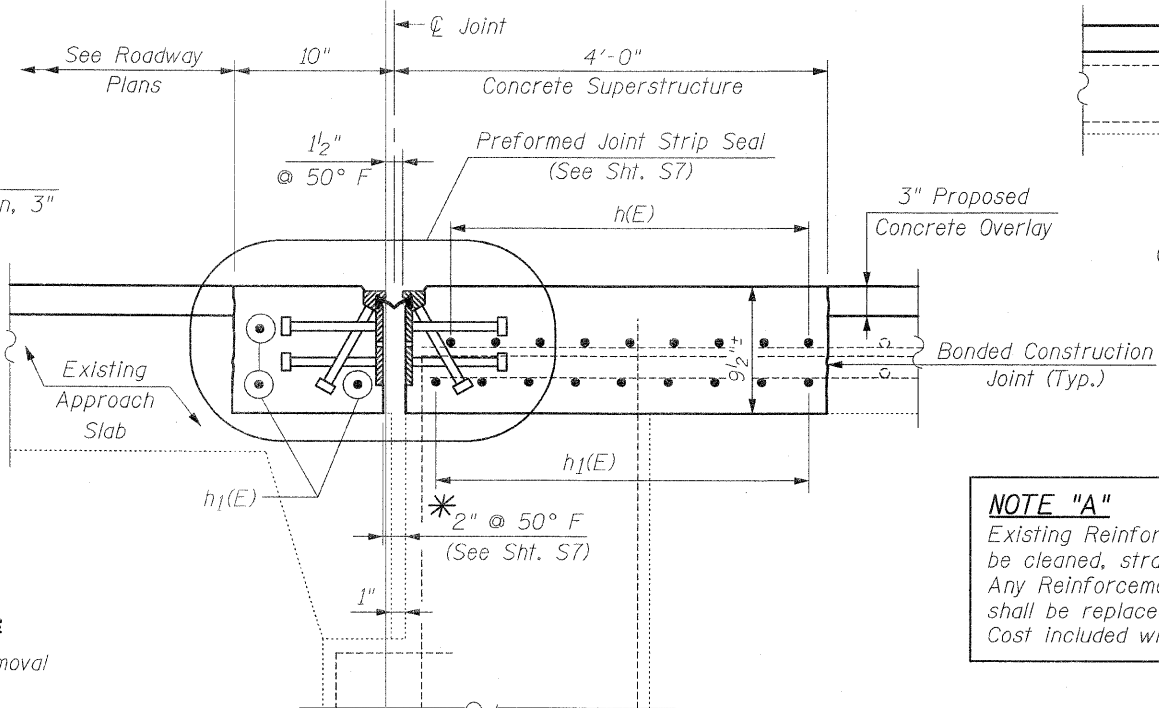

**SECTION A-A**

**EXPANSION JOINT AT ABUTMENTS**  
(Proposed)

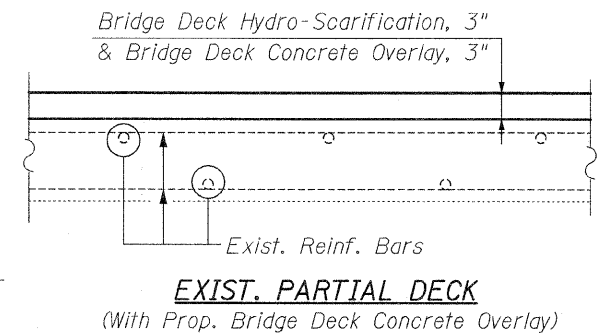

**NOTE "A"**  
Existing Reinforcement Bars extending into the Removal Area shall be cleaned, straightened and incorporated into the New Construction. Any Reinforcement Bars that are damaged during Concrete Removal shall be replaced with an approved Bar Splicer or Anchorage System. Cost included with Concrete Removal.

FILE NAME = exp_jt-reconst-II.sht	USER NAME = IOOT	DESIGNED - B.N.S.	REVISED -
		DRAWN - R.E.S./D.L./F.M.	REVISED -
		CHECKED - B.N.S./J.C.N.	REVISED -
		DATE - JANUARY 15, 2009	REVISED -

STATE OF ILLINOIS  
DEPARTMENT OF TRANSPORTATION

EXPANSION JOINT RECONSTRUCTION - II  
IL. 72 OVER I-90  
S.N. 045-0074

SCALE: SHEET NO. 55 OF 58 SHEETS STA. TO STA.

F.A.P. RTE. 341	SECTION N-4-C-I	COUNTY KANE	TOTAL SHEETS 32	SHEET NO. 17
FED. ROAD DIST. NO. ILLINOIS FED. AID PROJECT			CONTRACT NO. 60D72	



CHRISTIAN-ROGE & ASSOCIATES, INC.  
ENGINEERS / PLANNERS / SURVEYORS  
211 W. WACKER DRIVE CHICAGO, IL. 60606  
PHONE: (312)372-2023 FAX: (312)372-5274

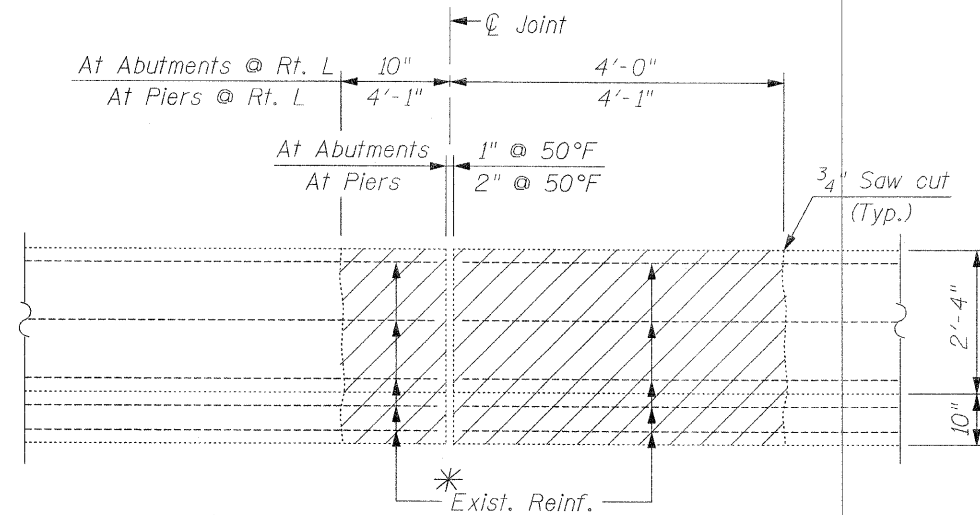

PARAPET & SIDEWALK CONCRETE REMOVAL

EXISTING

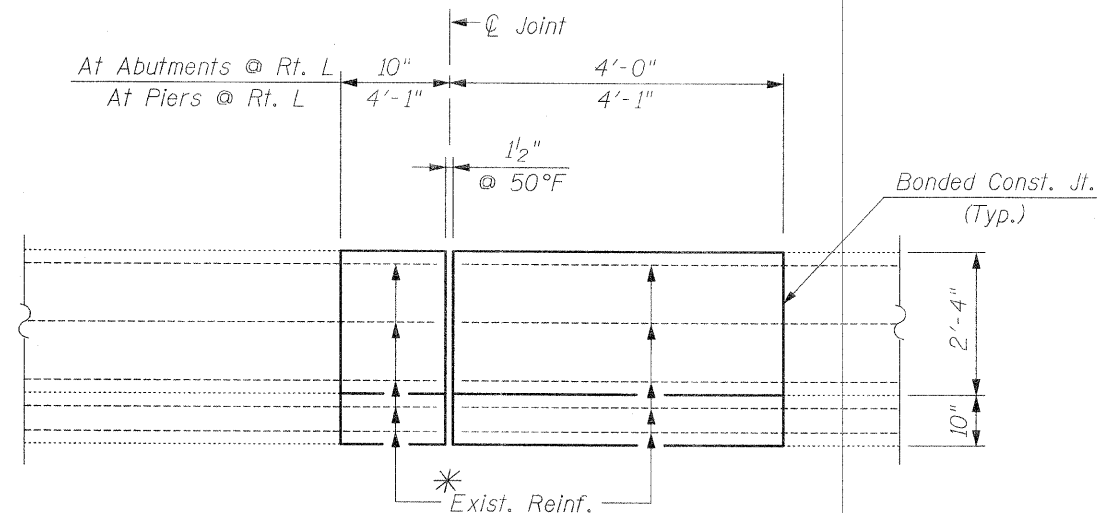

PARAPET & SIDEWALK CONCRETE REPLACEMENT

PROPOSED

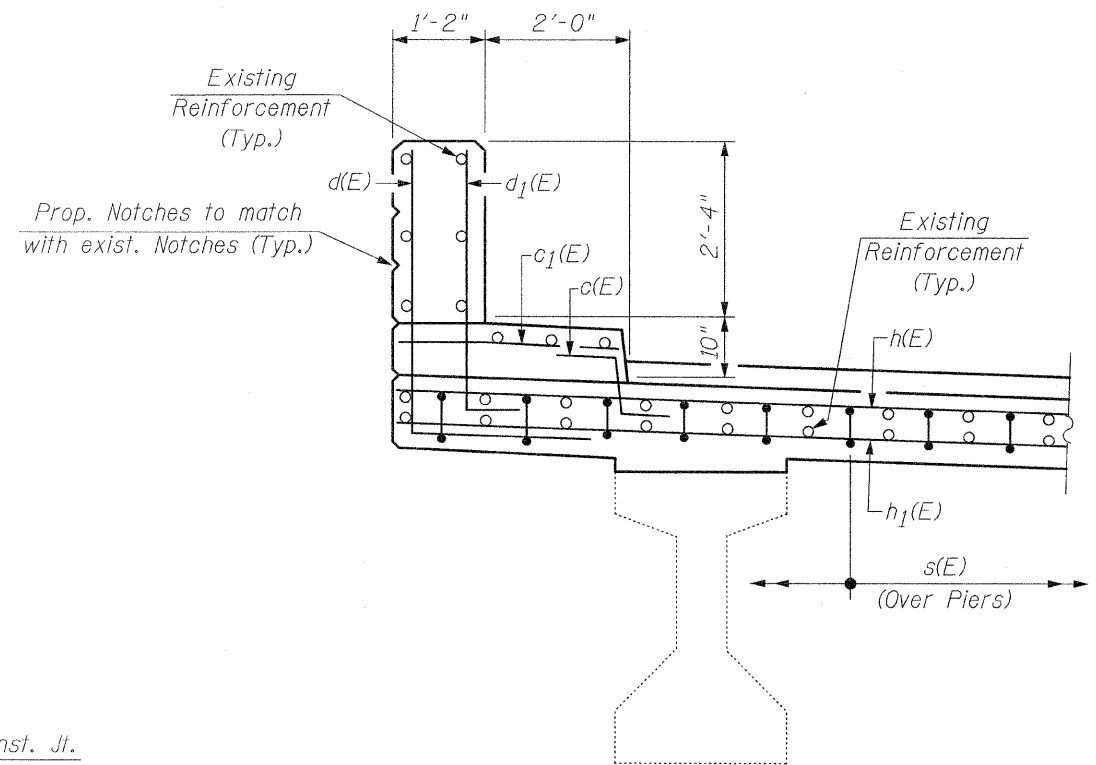

SECTION C-C

EAST PARAPET-SHOWN  
WEST PARAPET-SIMILAR

**NOTE:**  
Work This Sheet With Sht's. S4 & S5

\* Existing Reinforcement Bars extending into the Removal Area shall be cleaned, straightened and incorporated into the New Construction. Any Reinforcement Bars that are damaged during Concrete Removal shall be replaced with an approved Bar Splicer or Anchorage System. Cost included with Concrete Removal.



CHRISTIAN-ROGE & ASSOCIATES, INC.  
ENGINEERS / PLANNERS / SURVEYORS  
211 W. WACKER DRIVE CHICAGO, IL. 60606  
PHONE: (312)372-2023 FAX: (312)372-5274

FILE NAME = exp_jt_reconst-III.sht	USER NAME = IDOT	DESIGNED - B.N.S.	REVISED -
		DRAWN - R.E.S./D.L./F.M.	REVISED -
		CHECKED - B.N.S./J.C.N.	REVISED -
		DATE - JANUARY 15, 2009	REVISED -

STATE OF ILLINOIS  
DEPARTMENT OF TRANSPORTATION

EXPANSION JOINT RECONSTRUCTION - III  
IL. 72 OVER I-90  
S.N. 045-0074

SCALE: SHEET NO. S6 OF S8 SHEETS STA. TO STA.

F.A.P. RTE. 341	SECTION N-4-C-I	COUNTY KANE	TOTAL SHEETS 32	SHEET NO. 18
CONTRACT NO. 60D72			ILLINOIS FED. AID PROJECT	

\* Granular or solid flux filled headed studs conforming to Article 1006.32 of the Std. Specs., automatically end welded.

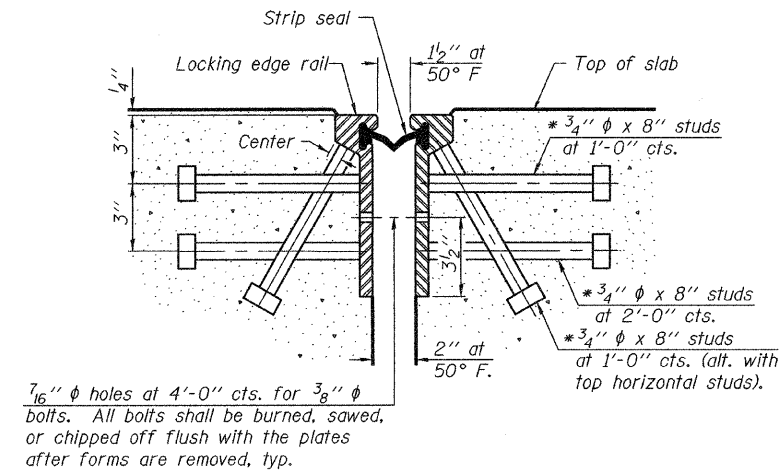

**SECTION THRU ROLLED RAIL JOINT**

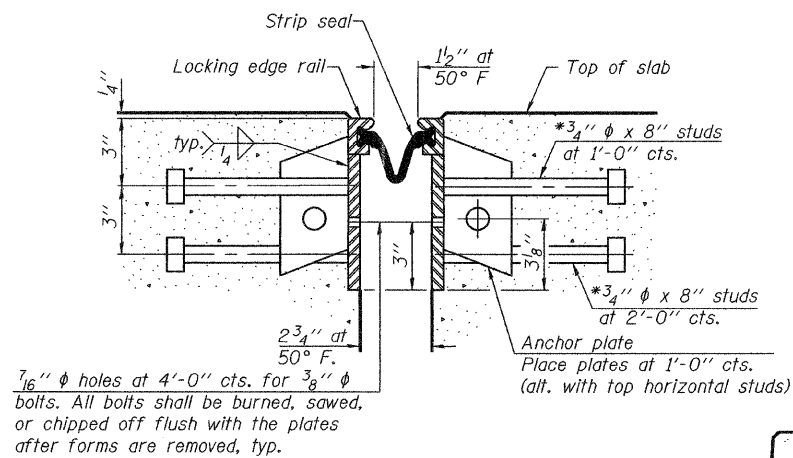

**SECTION THRU WELDED RAIL JOINT**

**Notes:**  
 The strip seal shall be made continuous and shall have a minimum thickness of 1/4". The configuration of the strip seal shall match the configuration of the Locking Edge Rails. Open or "webbed" strip seal gland configurations are not permitted. The gland shall be sized for a maximum rated movement of 4 inches.  
 The height and thickness of the Locking Edge Rails shown are minimum dimensions. The actual configuration of the Locking Edge Rails and matching strip seal may vary from manufacturer to manufacturer. Flanged edge rails will not be allowed. Locking Edge Rails may be spliced at slope discontinuities and stage construction joints.  
 The manufacturer's recommended installation methods shall be followed. The joint opening and deck dimensions detailed on the superstructure are based on a rolled rail expansion joint. If the Contractor elects to use the welded rail expansion joint, the opening and deck dimensions shall be modified according to the dimensions detailed on this sheet. Required modifications shall be made at no additional cost to the State.  
 All steel components shall be galvanized after fabrication according to Article 520.03 of the Standard Specifications.

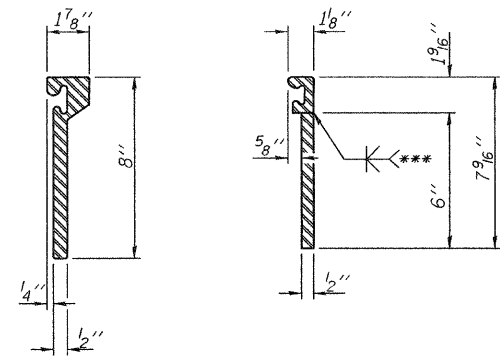

**ROLLED EXTRUDED RAIL WELDED RAIL**

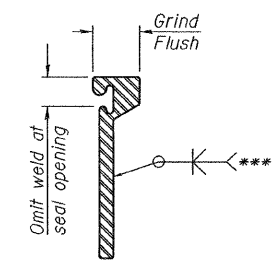

**LOCKING EDGE RAIL SPLICE**

The inside of the locking edge rail groove shall be free of weld residue.

**LOCKING EDGE RAILS**

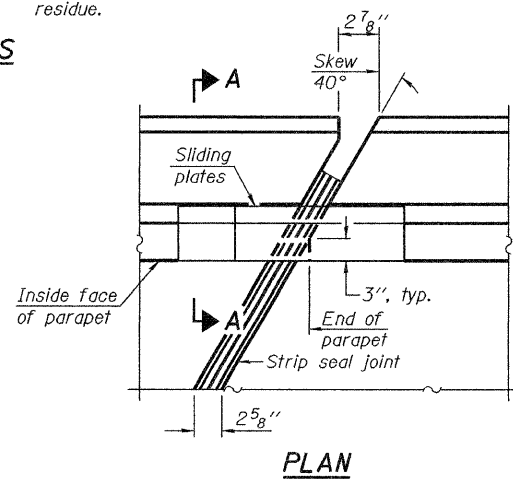

**PLAN**

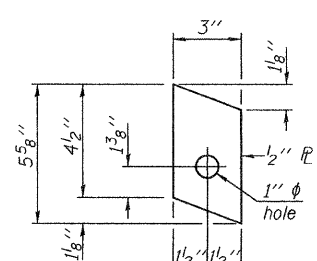

**ANCHOR PLATE (for welded rail)**

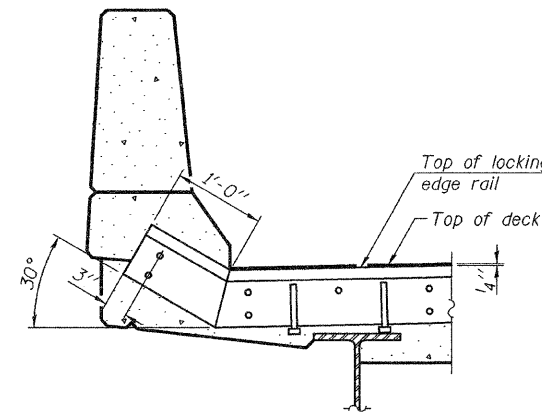

**AT PARAPET**

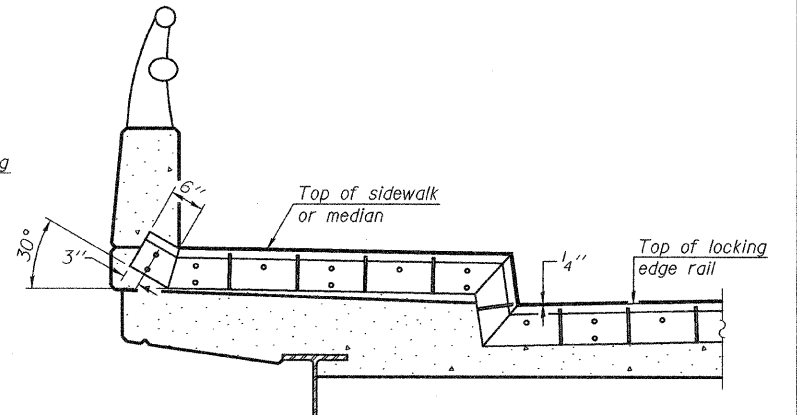

**AT SIDEWALK OR MEDIAN**

Shorter plates with a single row of studs at 12" cts. may be necessary on medians which are shallower than 9". See manufacturer's recommendation.

**TYPICAL END TREATMENTS**

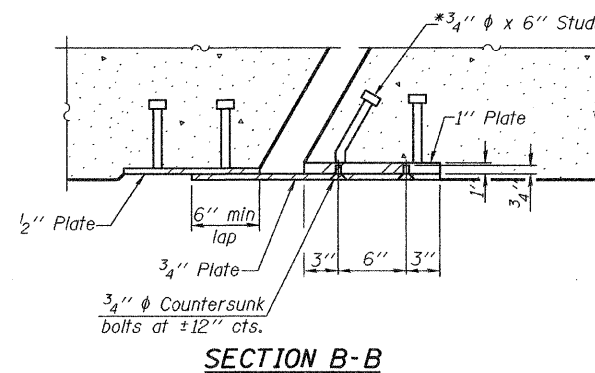

**SECTION B-B**

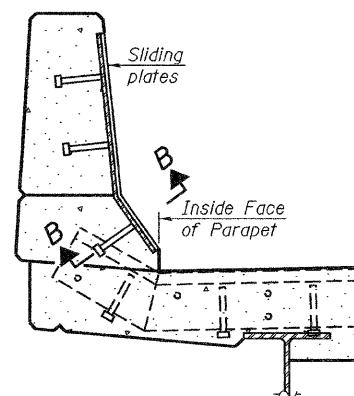

**SECTION A-A**

**POINT BLOCK DETAILS (for skews > 30°)**

**BILL OF MATERIAL**

Item	Unit	Total
Preformed Joint Strip Seal	Foot	225

EJ-SSJ

10-1-08

FILE NAME = #FILEL#	USER NAME = #USER#	DESIGNED -	REVISED -	STATE OF ILLINOIS DEPARTMENT OF TRANSPORTATION	PREFORMED JOINT STRIP SEAL IL. 72 OVER I-90 S.N. 045-0074	F.A.P. RTE. 341	SECTION N-4-C-1	COUNTY KANE	TOTAL SHEETS 32	SHEET NO. 19
PLOT SCALE = #SCALE#	CHECKED -	REVISED -	SCALE:			SHEET NO. 57 OF 58 SHEETS	STA. TO STA.	FED. ROAD DIST. NO.	ILLINOIS FED. AID PROJECT	CONTRACT NO. 60D72
PLOT DATE = #DATE#	DATE -	REVISED -								

The diameter of this part is equal or larger than the diameter of bar spliced.

The diameter of this part is the same as the diameter of the bar spliced.

**ROLLED THREAD DOWEL BAR**



**\*\* ONE PIECE**

Wire Connector



**WELDED SECTIONS**

**BAR SPLICER ASSEMBLY ALTERNATIVES**

\*\*Heavy Hex Nuts conforming to ASTM A 563, Grade C, D or DH may be used.

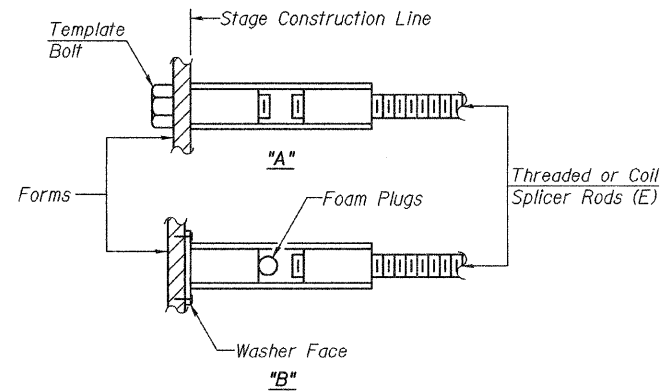

**INSTALLATION AND SETTING METHODS**

"A" : Set bar splicer assembly by means of a template bolt.  
 "B" : Set bar splicer assembly by nailing to wood forms or cementing to steel forms.  
 (E) : Indicates epoxy coating.

**NOTES**

Bar splicer assemblies shall be of an approved type and shall develop in tension at least 125 percent of the yield strength of the lapped reinforcement bars.  
 Splicer rods shall be of minimum 60 ksi yield strength, threaded or coiled full length.  
 All reinforcement bars shall be lapped and tied to the splicer rods or dowel bars.  
 Bar splicer assemblies shall be epoxy coated according to the requirements for reinforcement bars.

Other systems of similar design may be submitted to the Engineer for approval. Approval shall be based on certified test results from an approved testing laboratory that the proposed bar splicer assembly satisfies the following requirements:

- ① Minimum Capacity =  $1.25 \times f_y \times A_t$   
 (Tension in kips)
  - ② Minimum \*Pull-out Strength =  $0.66 \times f_y \times A_t$   
 (Tension in kips)
- Where  $f_y$  = Yield strength of lapped reinforcement bars in ksi.  
 $A_t$  = Tensile stress area of lapped reinforcement bars.  
 \* = 28 day concrete

**BAR SPLICER ASSEMBLIES**

Bar Size to be Spliced	Splicer Rod or Dowel Bar Length	Strength Requirements	
		Min. Capacity kips - tension	Min. Pull-Out Strength kips - tension
#4	1'-8"	14.7	7.9
#5	2'-2"	23.0	12.3
#6	2'-7"	33.1	17.4
#7	3'-5"	45.1	23.8
#8	4'-6"	58.9	31.3
#9	5'-9"	75.0	39.6
#10	7'-3"	95.0	50.3
#11	9'-0"	117.4	61.8

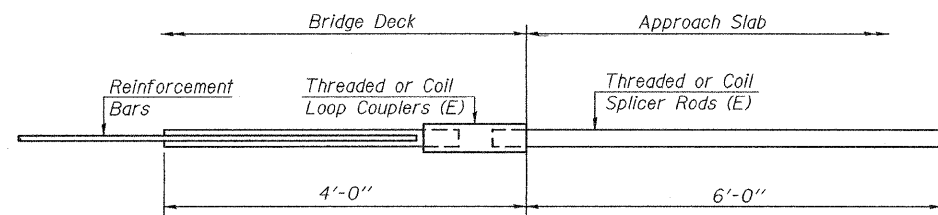

**FOR INTEGRAL OR SEMI-INTEGRAL ABUTMENTS**

Bar Splicer for #5 bar
Min. Capacity = 23.0 kips - tension
Min. Pull-out Strength = 12.3 kips - tension
No. Required =

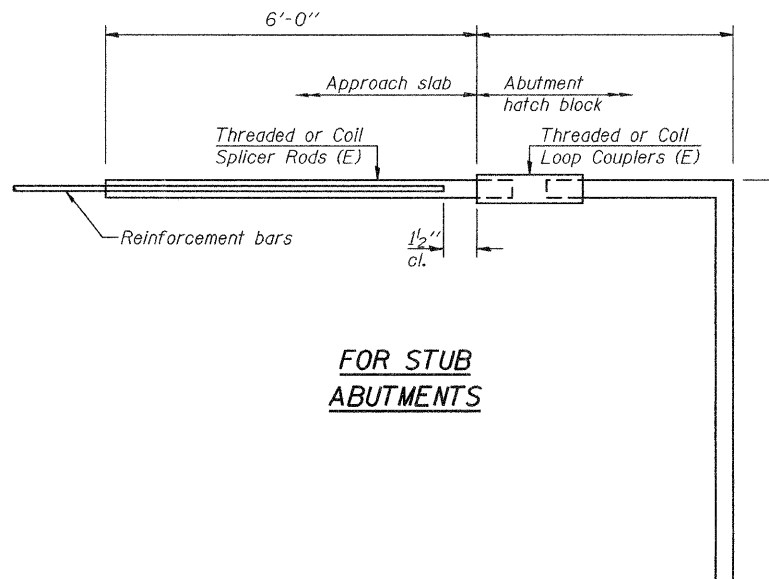

**FOR STUB ABUTMENTS**

Bar Splicer for #5 bar
Min. Capacity = 23.0 kips - tension
Min. Pull-out Strength = 12.3 kips - tension
No. Required =

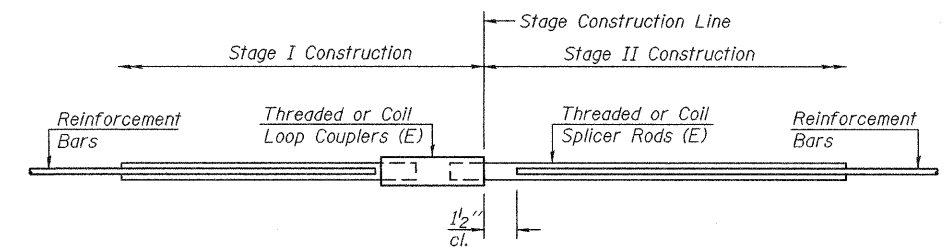

**STANDARD**

Bar Size	No. Assemblies Required	Location
#6	58	Expansion Joint
#7	64	Reconstruction

BSD-1

10-1-08

FILE NAME = #FILE#	USER NAME = #USER#	DESIGNED -	REVISED -	<b>STATE OF ILLINOIS DEPARTMENT OF TRANSPORTATION</b>	<b>BAR SPLICER ASSEMBLY DETAILS IL. 72 OVER I-90</b>	F.A.P. RTE. 341	SECTION N-4-C-1	COUNTY KANE	TOTAL SHEETS 32	SHEET NO. 20
PLOT SCALE = #SCALE#	CHECKED -	REVISED -	S.N. 045-0074			CONTRACT NO. 60D72				
PLOT DATE = #DATE#	DATE -	REVISED -	SCALE:			SHEET NO. 58 OF 58 SHEETS	STA. TO STA.	FED. ROAD DIST. NO.	ILLINOIS FED. AID PROJECT	

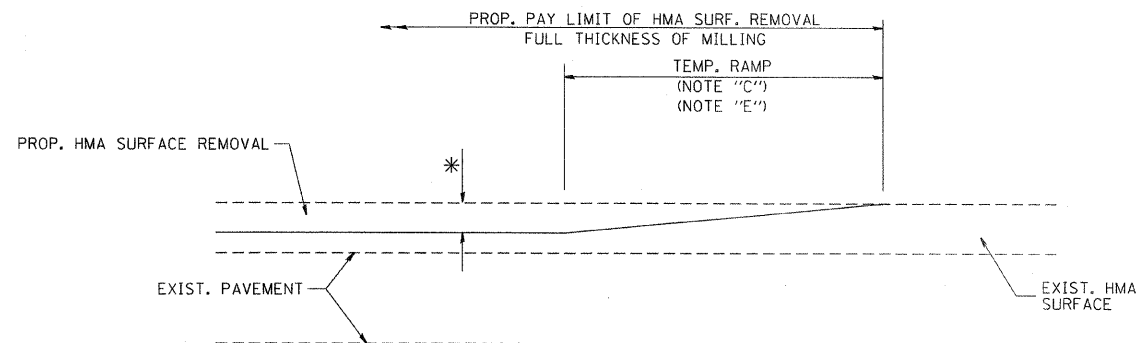

MILLED TEMPORARY RAMP  
(FOR BUTT JOINT AND HMA TAPER SEE DETAIL BELOW)

**OPTION 1**

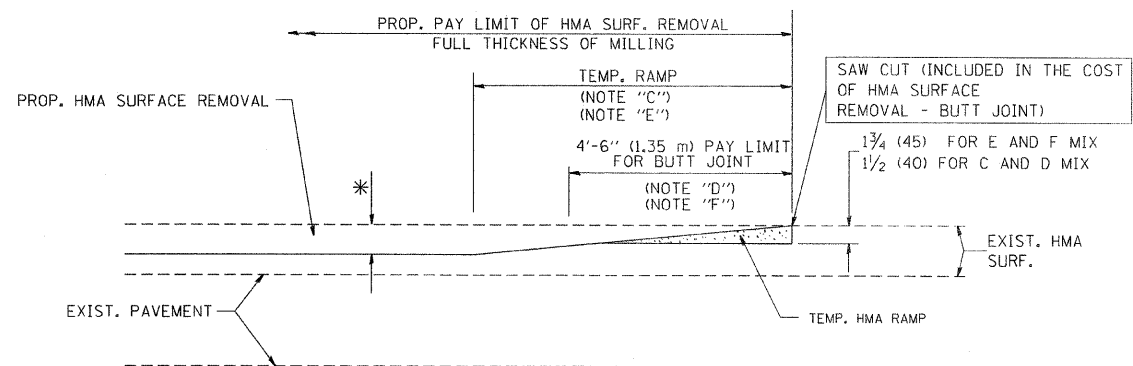

HMA CONSTRUCTED TEMPORARY RAMP  
(FOR BUTT JOINT AND HMA TAPER SEE DETAIL BELOW)

**OPTION 2**

**TYPICAL TEMPORARY RAMP**

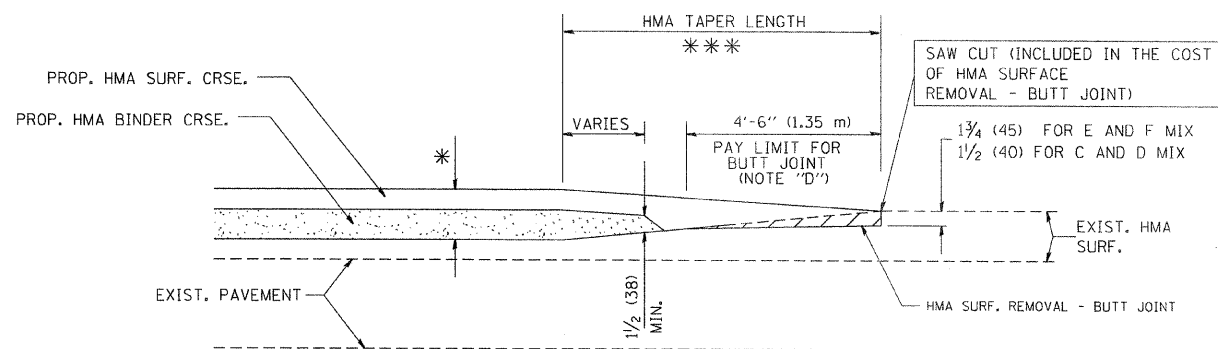

BUTT JOINT AND HMA TAPER

**TYPICAL BUTT JOINT AND HMA TAPER FOR MILLING AND RESURFACING**

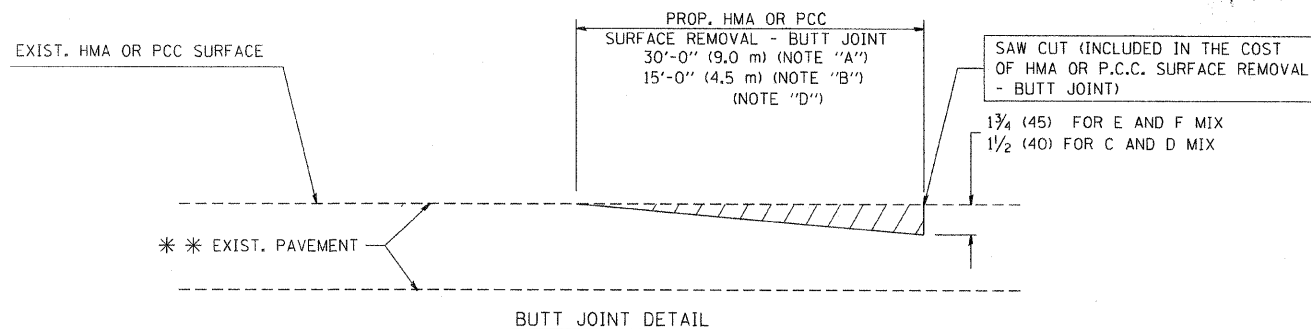

BUTT JOINT DETAIL

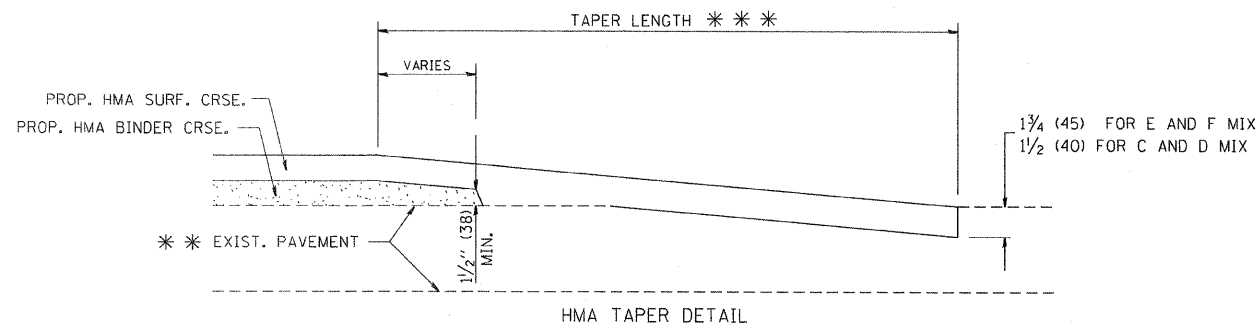

HMA TAPER DETAIL

**TYPICAL BUTT JOINT AND HMA TAPER FOR RESURFACING ONLY**

\*\*\* PC CONCRETE, HMA OR HMA RESURFACED PAVEMENT.

**NOTES**

- A: MAINLINE ROADWAYS AND MAJOR SIDE ROADS.
  - B: MINOR SIDE ROADS.
  - C: THE TEMP. RAMP SHALL BE CONSTRUCTED IMMEDIATELY UPON REMOVAL OF THE EXISTING HMA SURFACE.
  - D: THE BUTT JOINT SHALL BE CONSTRUCTED IMMEDIATELY PRIOR TO PLACING THE PROPOSED HMA COURSES.
  - E: TAPER THE TEMP. RAMP AT A RATE OF 3'-0" (900 mm) PER 1 INCH (25 mm) OF MILLING THICKNESS.
  - F: INSTALLATION AND REMOVAL OF THE 4'-6" (1.35 m) TEMP. RAMP IS INCLUDED IN COST OF HMA SURFACE REMOVAL - BUTT JOINT
  - G: SEE ARTICLE 406.08 AND 406.14 OF THE STANDARD SPECIFICATIONS FOR "HMA AND/OR PCC SURFACE REMOVAL, BUTT JOINT".
- \* SEE TYPICAL SECTIONS FOR MILLING THICKNESS.
- \*\*\* 20'-0" (6.1 m) PER 1 (25) RESURFACING (NOTE "A")  
10'-0" (3.0 m) PER 1 (25) RESURFACING (NOTE "B")

**BASIS OF PAYMENT:**

THE BUTT JOINT WILL BE PAID FOR AT THE CONTRACT UNIT PRICE PER SQUARE YARD (SQUARE METER) FOR "HOT-MIX ASPHALT SURFACE REMOVAL - BUTT JOINT" OR FOR "PORTLAND CEMENT CONCRETE SURFACE REMOVAL - BUTT JOINT".

ALL DIMENSIONS ARE IN INCHES (MILLIMETERS) UNLESS OTHERWISE SHOWN.

FILE NAME = W:\diststd\22x34\bd32.dgn	USER NAME = geglionobt	DESIGNED - M. DE YONG	REVISED - R. SHAH 10-25-94
		DRAWN -	REVISED - A. ABBAS 03-21-97
	PLOT SCALE = 50.0000' / IN.	CHECKED -	REVISED - M. GOMEZ 04-06-01
	PLOT DATE = 1/4/2008	DATE - 06-13-90	REVISED - R. BORO 01-01-07

**STATE OF ILLINOIS  
DEPARTMENT OF TRANSPORTATION**

<b>BUTT JOINT AND HMA TAPER DETAILS</b>	
SCALE: NONE	SHEET NO. 1 OF 1 SHEETS
STA. 179+00	TO STA. 194+00

F.A.P. RTE. 341	SECTION N-4-C-1	COUNTY KANE	TOTAL SHEETS 32	SHEET NO. 21
BD400-05 BD32			CONTRACT NO. 60D72	
FED. ROAD DIST. NO. 1 ILLINOIS FED. AID PROJECT				

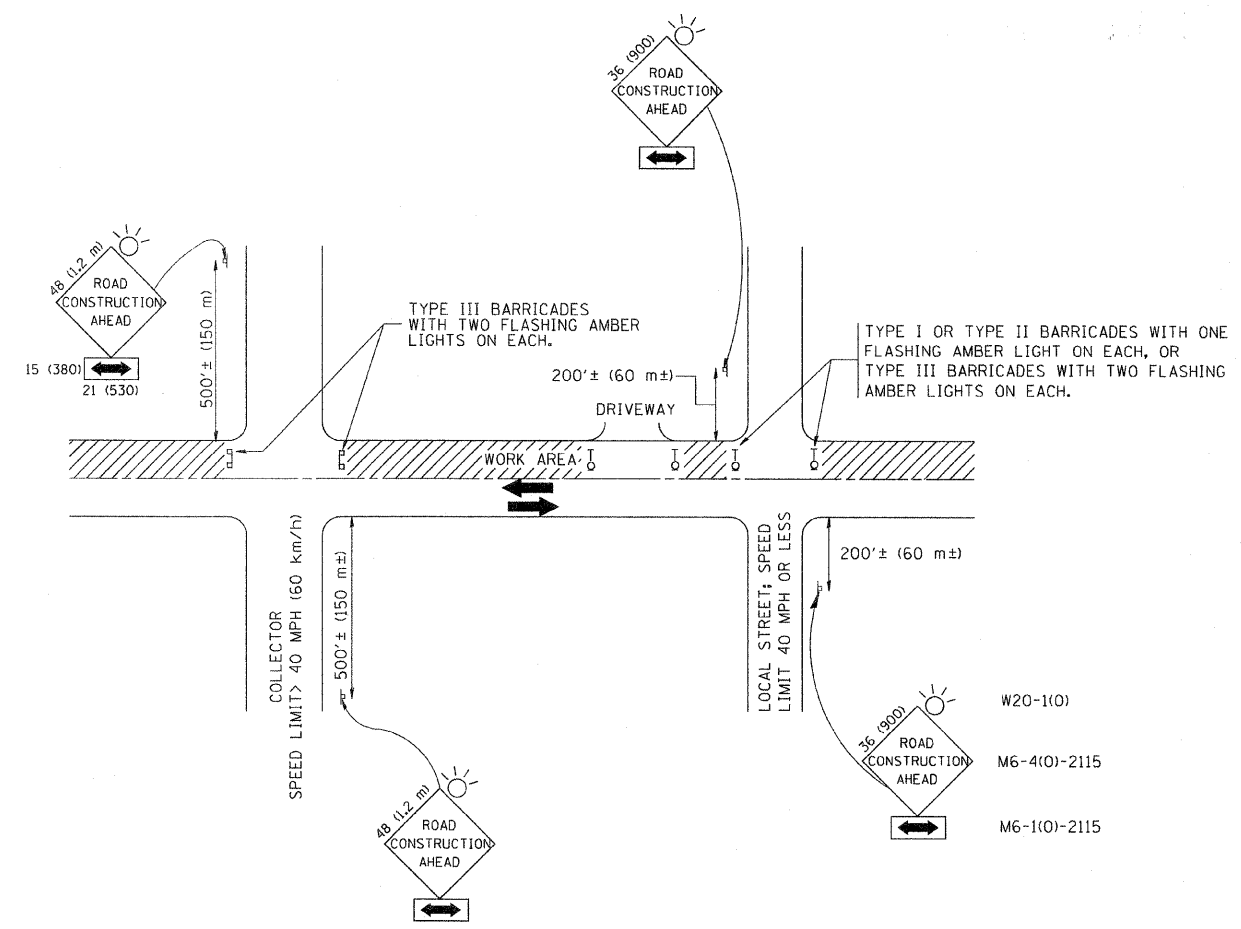

TRAFFIC CONTROL AND PROTECTION FOR SIDE ROADS, INTERSECTIONS, AND DRIVEWAYS

NOTES:

- A. FOR NO LANE RESTRICTION ON THE SIDE ROAD OR DRIVEWAYS
  1. SIDE ROAD WITH A SPEED LIMIT OF 40 MPH (60 km/h) OR LESS AS SHOWN ON THE DRAWING AND AS DIRECTED BY THE ENGINEER:
    - a) ONE ROAD CONSTRUCTION AHEAD SIGN 36 x 36 (900x900) WITH A FLASHER AND FLAG MOUNTED ON IT APPROXIMATELY 200' (60 m) IN ADVANCE OF THE MAIN ROUTE.
    - b) THE CLOSED PORTION OF THE MAIN ROUTE SHALL BE PROTECTED BY BLOCKING WITH TYPE I, TYPE II OR TYPE III BARRICADES, 1/3 OF THE CROSS SECTION OF THE CLOSED PORTION.
  2. SIDE ROAD WITH A SPEED LIMIT GREATER THAN 40 MPH (60 km/h) AS SHOWN ON THE DRAWING AND AS DIRECTED BY THE ENGINEER:
    - a) ONE ROAD CONSTRUCTION AHEAD SIGN 48 x 48 (1.2 m x 1.2 m) WITH A FLASHER MOUNTED ON IT APPROXIMATELY 500' (150 m) IN ADVANCE OF THE MAIN ROUTE.
    - b) THE CLOSED PORTION OF THE MAIN ROUTE SHALL BE PROTECTED BY BLOCKING WITH TYPE III BARRICADES, 1/2 OF THE CROSS SECTION OF THE CLOSED PORTION.
  3. WHEN THE SIDE ROAD LIES BETWEEN THE BEGINNING OF THE MAINLINE SIGNING AND THE WORK ZONE, A SINGLE HEADED ARROW (M6-1) SHALL BE USED IN LIEU OF THE DOUBLE HEADED ARROW (M6-4).
- B. FOR A LANE CLOSURE ON A SIDE ROAD OR DRIVEWAY:
 

USE APPLICABLE PORTIONS OF THE TYPICAL APPLICATION OF TRAFFIC CONTROL DEVICES (STD. 701501, STD. 701606 OR THE APPROPRIATE STANDARD). THE SPACING OF SIGNS AND BARRICADES SHALL BE ADJUSTED FOR FIELD CONDITIONS AS DIRECTED BY THE ENGINEER. THE DIRECTIONAL ARROW SHALL BE COVERED OR REMOVED WHEN NO LONGER CONSISTENT WITH THE SIDE ROAD LANE CLOSURE.
- C. ADVANCE WARNING SIGNS ARE TO BE OMITTED ON DRIVEWAY UNLESS OTHERWISE NOTED.
- D. THE TRAFFIC CONTROL AND PROTECTION FOR SIDE ROADS, INTERSECTIONS, AND DRIVEWAYS SHALL BE INCIDENTAL TO THE COST OF SPECIFIED TRAFFIC CONTROL STANDARDS OR ITEMS.

All dimensions are in millimeters (inches) unless otherwise shown.

FILE NAME = W:\diststd\22x34\tc10.dgn	USER NAME = geg11anobt	DESIGNED - LHA	REVISED - J. OBERLE 10-18-95
		DRAWN -	REVISED - A. HOUSEH 03-06-96
		CHECKED -	REVISED - A. HOUSEH 10-15-96
		DATE - 06-89	REVISED - T. RAMMACHER 01-06-00

STATE OF ILLINOIS  
DEPARTMENT OF TRANSPORTATION

TRAFFIC CONTROL AND PROTECTION FOR SIDE ROADS, INTERSECTIONS, AND DRIVEWAYS			
SCALE: NONE	SHEET NO. 1 OF 1 SHEETS	STA. 179+00	TO STA. 194+00

F.A.P. RTE.	SECTION	COUNTY	TOTAL SHEETS	SHEET NO.
341	N-4-C-1	KANE	32	22
TC-10			CONTRACT NO. 60D72	
FED. ROAD DIST. NO. 1 ILLINOIS FED. AID PROJECT				

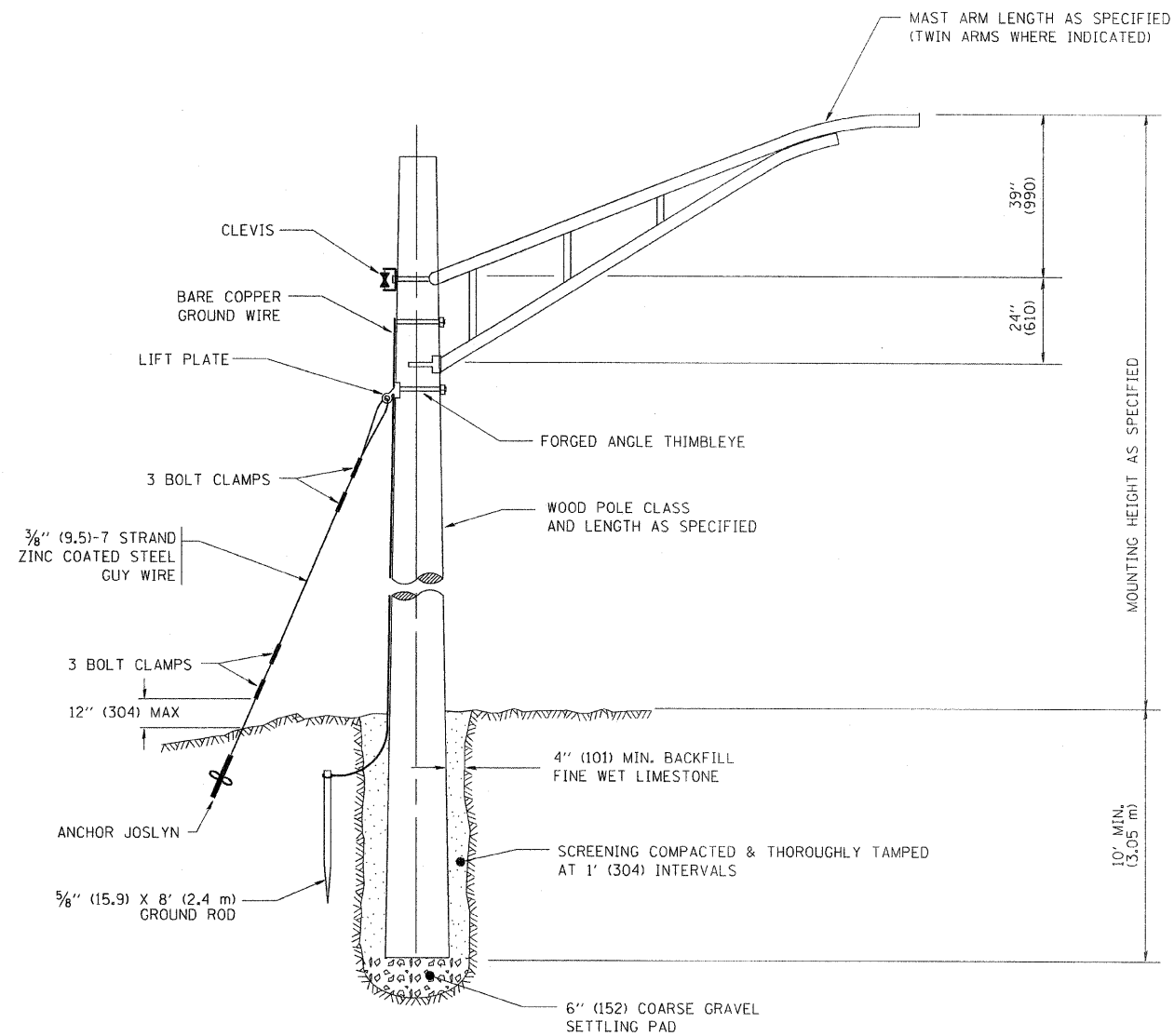

TEMPORARY LIGHT POLE DETAIL

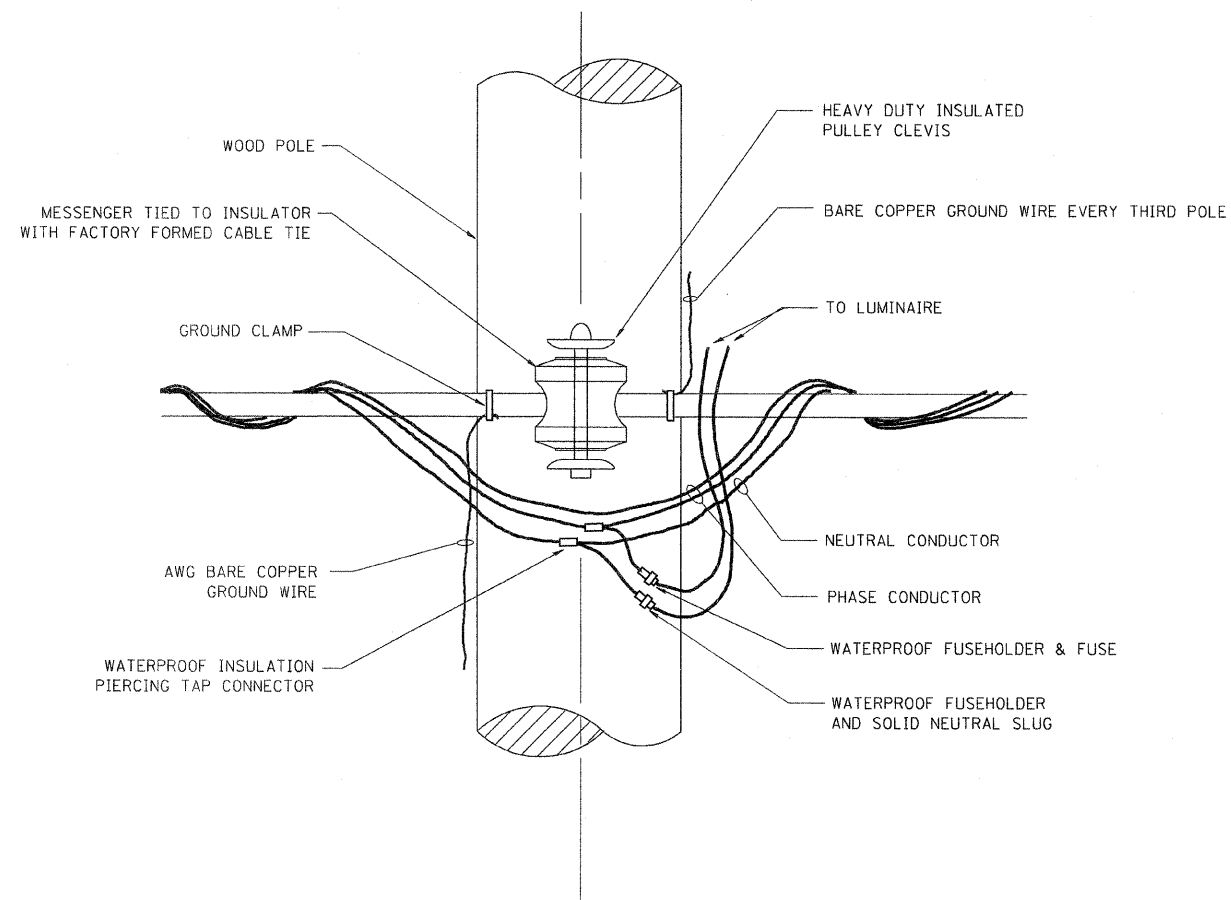

TEMPORARY LIGHT POLE ATTACHMENT DETAIL

NOTES:

1. ALL DIMENSIONS IN INCHES (MILLIMETERS) UNLESS OTHERWISE INDICATED

FILE NAME = W:\disto\td\22x34\be008.dgn	USER NAME = geglencbt	DESIGNED -	REVISED - 08-08-03	<b>STATE OF ILLINOIS DEPARTMENT OF TRANSPORTATION</b>	<b>TEMPORARY LIGHT POLE DETAILS</b>			F.A.P. RTE.	SECTION	COUNTY	TOTAL SHEETS	SHEET NO.
	PLOT SCALE = 50,000' / IN.	CHECKED -	REVISED -					341	N-4-C-1	KANE	32	23
PLOT DATE = 1/4/2008	DATE -	REVISED -		SCALE: NONE SHEET NO. 1 OF 1 SHEETS STA. 179+00 TO STA. 194+00			FED. ROAD DIST. NO. 1 ILLINOIS FED. AID PROJECT					
							CONTRACT NO. 60D72					

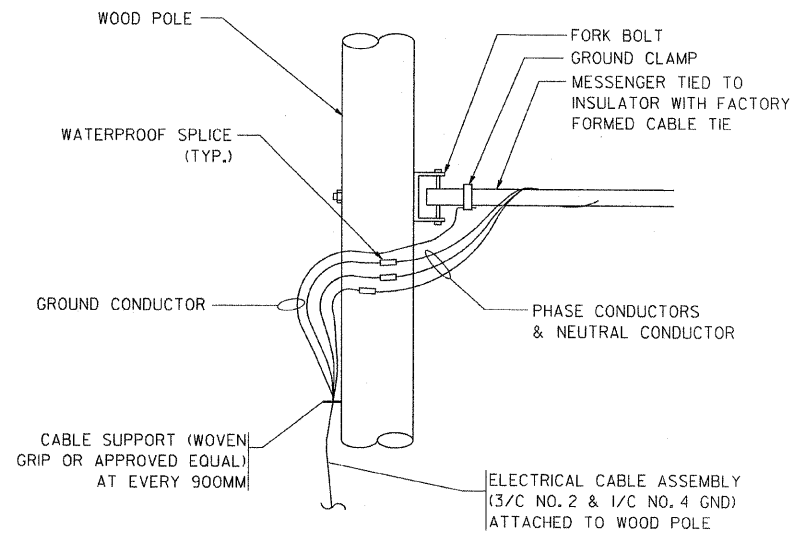

**AERIAL CABLE CONNECTION DETAIL**  
N.T.S.

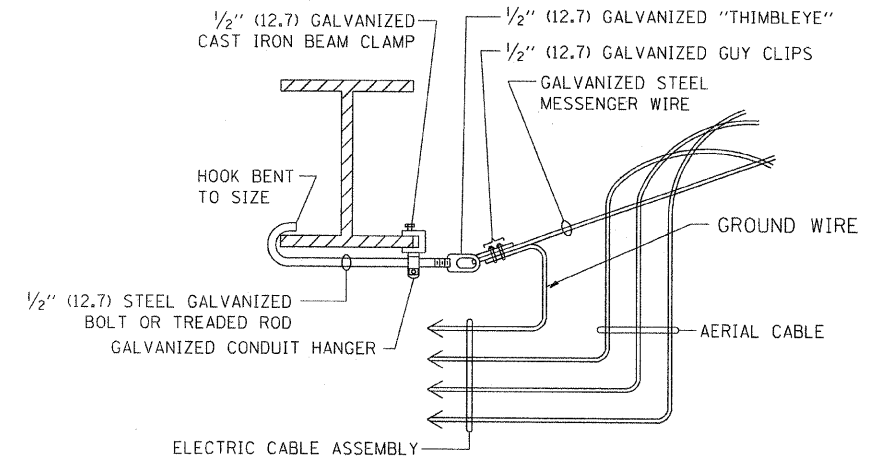

**AERIAL CABLE ATTACHED TO STRUCTURE**  
NOT TO SCALE

**NOTES:**

1. ALL DIMENSIONS IN INCHES (MILLIMETERS) UNLESS OTHERWISE INDICATED.
2. SEE PROPOSED LIGHTING PLAN FOR CONDUIT, CABLE AND ROUTING.
3. THE CONTRACTOR SHALL PROVIDE INTERMEDIATE SUPPORTS TO MAINTAIN MINIMUM CLEARANCES. REFER TO AERIAL AERIAL CABLE ATTACHED TO STRUCTURE DETAIL.
4. COST OF SPLICES AND MOUNTING HARDWARE SHALL BE INCLUDED IN THE UNIT PRICE FOR AERIAL CABLE.

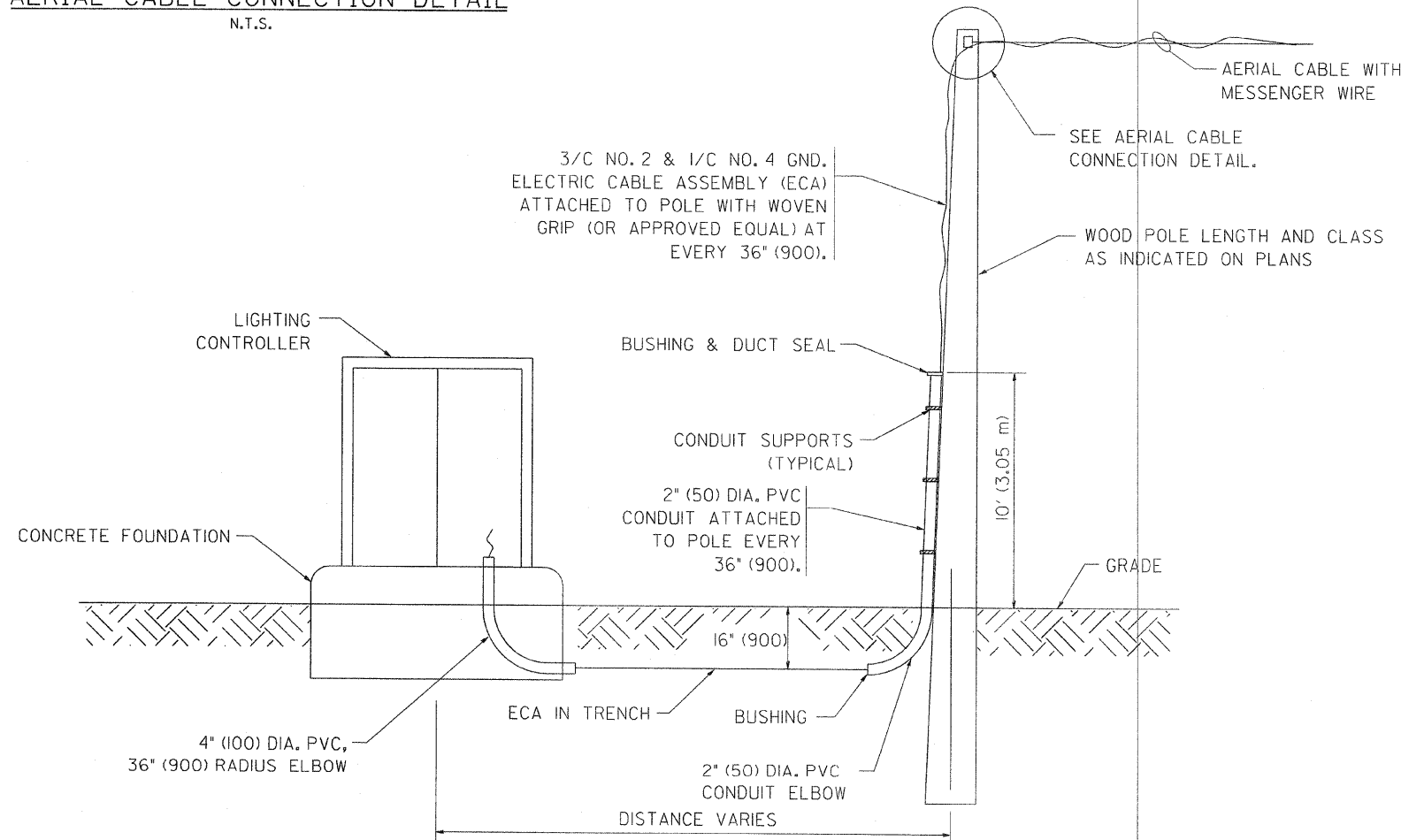

**WOOD POLE TO LIGHTING CONTROLLER WIRING CONNECTION DETAIL**  
N.T.S.

FILE NAME = W:\dststd\22x34\be801.dgn	USER NAME = geglionab	DESIGNED -	REVISED - 08-08-03
		DRAWN -	REVISED -
	PLOT SCALE = 50,000' / IN.	CHECKED -	REVISED -
	PLOT DATE = 1/4/2008	DATE -	REVISED -

**STATE OF ILLINOIS  
DEPARTMENT OF TRANSPORTATION**

**TEMPORARY AERIAL CABLE INSTALLATION**

SCALE: NONE SHEET NO. 1 OF 1 SHEETS STA. 179+00 TO STA. 194+00

F.A.P. RTE.	SECTION	COUNTY	TOTAL SHEETS	SHEET NO.
341	N-4-C-1	KANE	32	24
BE-801			CONTRACT NO. 60D72	
FED. ROAD DIST. NO. 1 ILLINOIS FED. AID PROJECT				



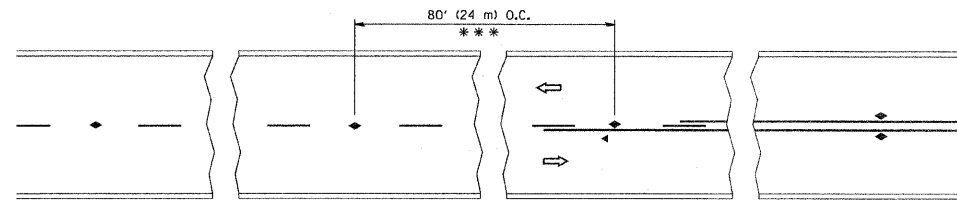

\*\*\* REDUCE TO 40' (12 m) O.C. ON CURVES WITH POSTED OR ADVISORY SPEED 45 M.P.H. (70 km/h) OR LESS.

TWO-LANE/TWO-WAY

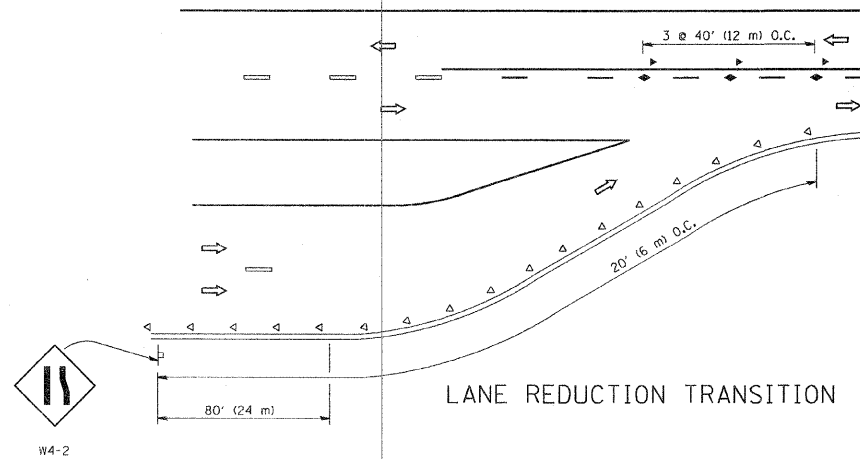

LANE REDUCTION TRANSITION

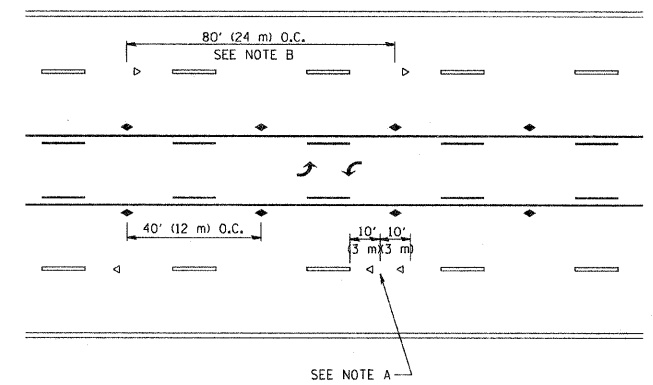

TWO-WAY LEFT TURN

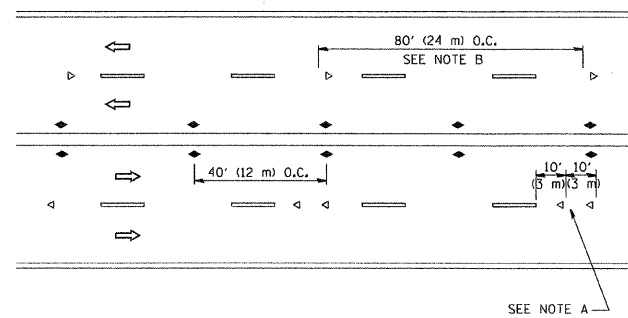

MULTI-LANE/UNDIVIDED

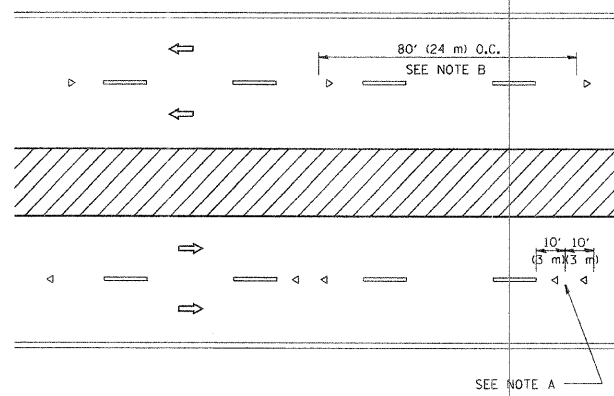

MULTI-LANE/DIVIDED

GENERAL NOTES

1. MARKERS USED WITH DASHED LINES SHALL BE CENTERED IN THE GAP BETWEEN SEGMENTS.
2. MARKERS USED ADJACENT TO SOLID LINES SHALL BE OFFSET 2 TO 3 (50 TO 75) TOWARD TRAFFIC AS SHOWN.
3. MARKERS THROUGH TANGENTS LESS THAN 500' (150 m) IN LENGTH BETWEEN CURVES SHALL BE INSTALLED AT THE LESSER OF THE TWO CURVE SPACINGS.

LANE MARKER NOTES

- B. REDUCE TO 40' (12 m) O.C. ON CURVES WHERE ADVISORY SPEEDS ARE 10 M.P.H. (20 km/h) LOWER THAN POSTED SPEEDS.
- A. USE DOUBLE LANE LINE MARKERS SPACED AS SHOWN.

SYMBOLS

- YELLOW STRIPE
- WHITE STRIPE
- ◀ ONE-WAY AMBER MARKER
- ◀ ONE-WAY CRYSTAL MARKER (W/O)
- ◆ TWO-WAY AMBER MARKER

DESIGN NOTES

1. DOUBLE LANE LINE MARKERS SHALL BE USED UNLESS SPECIFIED OTHERWISE.
2. EXCEPT AS SHOWN ON THE LANE REDUCTION TRANSITION AND FREEWAY EXIT RAMP DETAIL, MARKERS ARE NOT TO BE SPECIFIED ON RIGHT EDGE LINES.
3. THE EXACT MARKER LIMITS, SPACING, AND COLOR SHOULD BE INCLUDED IN THE PLANS.
4. MARKERS SHOULD NOT BE USED ALONGSIDE CURBS EXCEPT FOR EXTREMELY SHORT SECTIONS OF CURBS WHERE NOT MORE THAN TWO MARKERS WOULD BE INVOLVED.

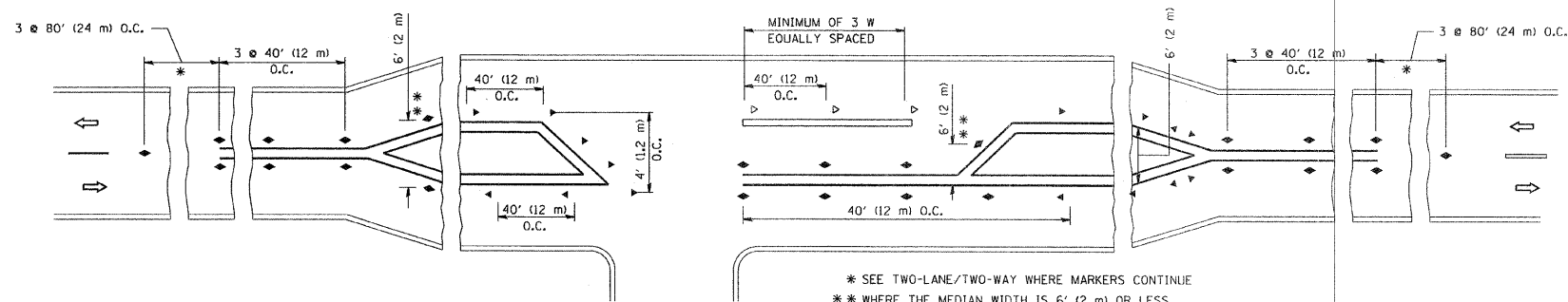

LEFT TURN

All dimensions are in inches (millimeters) unless otherwise shown.

FILE NAME = W:\distatd\22x34\td11.dgn	USER NAME = gegl1enobt	DESIGNED -	REVISED - T. RAMMACHER 09-19-94	<b>STATE OF ILLINOIS DEPARTMENT OF TRANSPORTATION</b>	<b>TYPICAL APPLICATIONS RAISED REFLECTIVE PAVEMENT MARKERS (SNOW-PLOW RESISTANT)</b>			F.A.P. RTE.	SECTION	COUNTY	TOTAL SHEETS	SHEET NO.
	PLOT SCALE = 50,000 / IN.	CHECKED -	REVISED - T. RAMMACHER 03-12-99					341	N-4-C-1	KANE	32	25
PLOT DATE = 1/4/2008	DATE -	REVISED - T. RAMMACHER 01-06-00	REVISED -	SCALE: NONE	SHEET NO. 1 OF 1 SHEETS	STA. 179+00 TO STA. 194+00	<b>TC-11</b> FED. ROAD DIST. NO. 1 ILLINOIS FED. AID PROJECT					
							<b>CONTRACT NO. 60D72</b>					

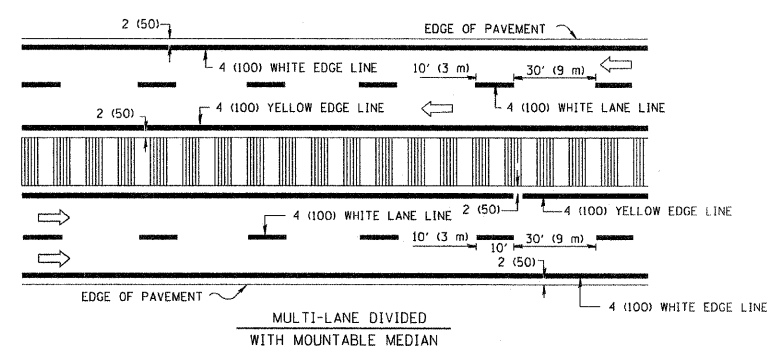
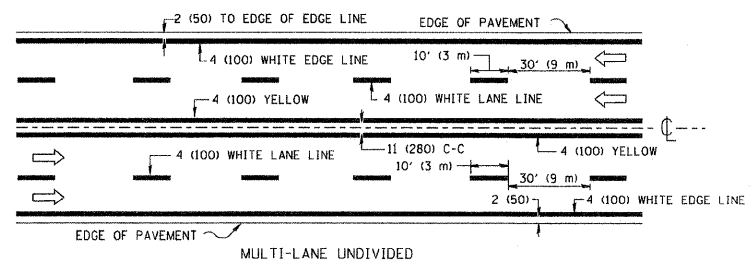
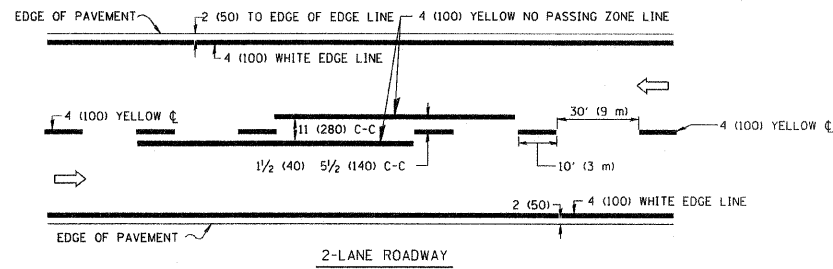

NOTE: MEDIANS WITH BARRIER CURB DO NOT REQUIRE AN EDGE LINE

TYPICAL LANE AND EDGE LINE MARKING

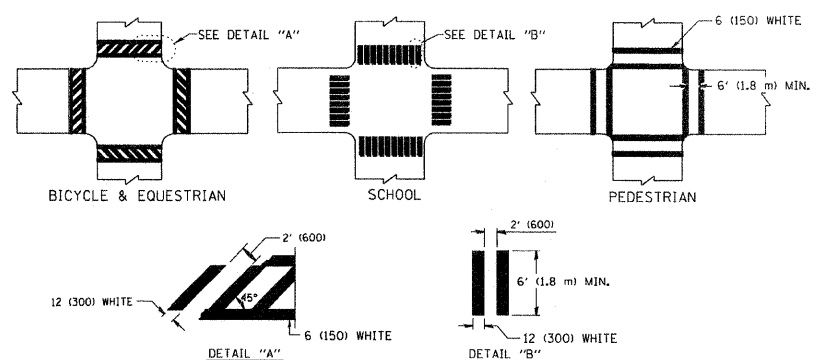

TYPICAL CROSSWALK MARKING

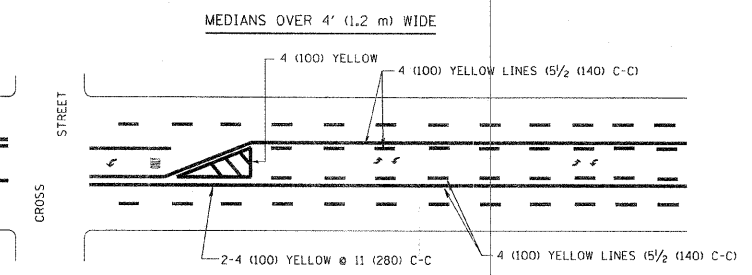
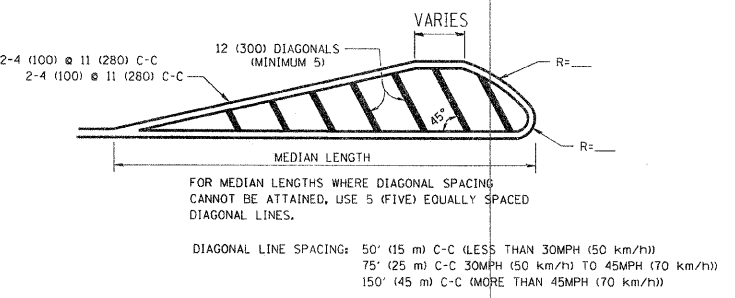
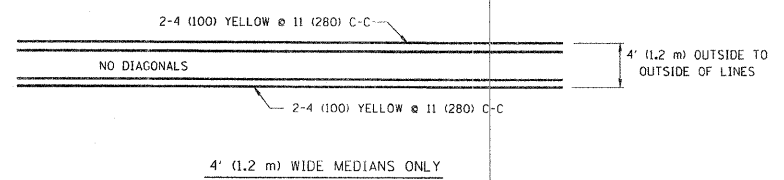

TYPICAL PAINTED MEDIAN MARKING

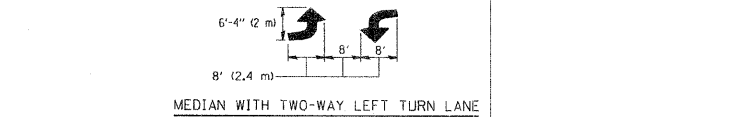

TYPICAL TURN LANE MARKING

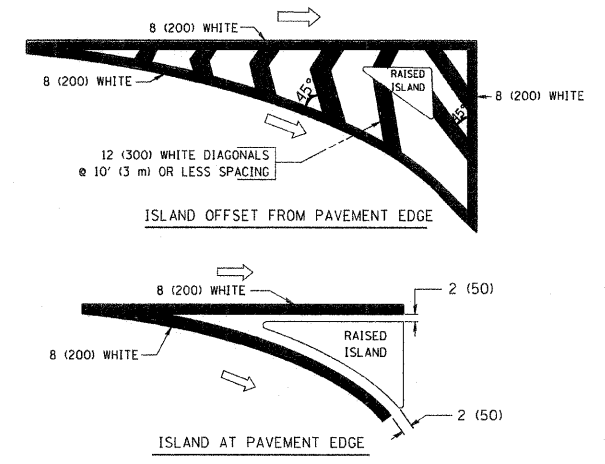

TYPICAL ISLAND MARKING

TYPE OF MARKING	WIDTH OF LINE	PATTERN	COLOR	SPACING / REMARKS
CENTERLINE ON 2 LANE PAVEMENT	4 (100)	SKIP-DASH	YELLOW	10' (3 m) LINE WITH 30' (9 m) SPACE
CENTERLINE ON MULTI-LANE UNDIVIDED PAVEMENT	2 @ 4 (100)	SOLID	YELLOW	11 (280) C-C
NO PASSING ZONE LINES: FOR ONE DIRECTION FOR BOTH DIRECTIONS	4 (100) 2 @ 4 (100)	SOLID SOLID	YELLOW YELLOW	5 1/2 (140) C-C FROM SKIP-DASH CENTERLINE 11 (280) C-C OMIT SKIP-DASH CENTERLINE BETWEEN
LANE LINES	4 (100) 5 (125) ON FREEWAYS	SKIP-DASH SKIP-DASH	WHITE WHITE	10' (3 m) LINE WITH 30' (9 m) SPACE
DOTTED LINES (EXTENSIONS OF CENTER, LANE OR TURN LANE MARKINGS)	SAME AS LINE BEING EXTENDED	SKIP-DASH	SAME AS LINE BEING EXTENDED	2' (600) LINE WITH 6' (1.8 m) SPACE
EDGE LINES	4 (100)	SOLID	YELLOW-LEFT WHITE-RIGHT	OUTLINE MOUNTABLE MEDIANS IN YELLOW; EDGE LINES ARE NOT USED NEXT TO BARRIER CURB
TURN LANE MARKINGS	6 (150) LINE; FULL SIZE LETTERS & SYMBOLS (8' (2.4m))	SOLID	WHITE	SEE TYPICAL TURN LANE MARKING DETAIL
TWO WAY LEFT TURN MARKING	2 @ 4 (100) EACH DIRECTION 8' (2.4m) LEFT ARROW	SKIP-DASH AND SOLID IN PAIRS	YELLOW WHITE	10' (3 m) LINE WITH 30' (9 m) SPACE FOR SKIP-DASH; 5 1/2 (140) C-C BETWEEN SOLID LINE AND SKIP-DASH LINE SEE TYPICAL TWO-WAY LEFT TURN MARKING DETAIL
CROSSWALK LINES (PEDESTRIAN) A. DIAGONALS (BIKE & EQUESTRIAN) B. LONGITUDINAL BARS (SCHOOL)	2 @ 6 (150) 12 (300) @ 45° 12 (300) @ 90°	SOLID SOLID SOLID	WHITE WHITE WHITE	NOT LESS THAN 6' (1.8 m) APART 2' (600) APART SEE TYPICAL CROSSWALK MARKING DETAILS.
STOP LINES	24 (600)	SOLID	WHITE	PLACE 4' (1.2 m) IN ADVANCE OF AND PARALLEL TO CROSSWALK, IF PRESENT. OTHERWISE, PLACE AT DESIRED STOPPING POINT, PARALLEL TO CROSSROAD CENTERLINE, WHERE POSSIBLE.
PAINTED MEDIANS	2 @ 4 (100) WITH 12 (300) DIAGONALS @ 45° NO DIAGONALS USED FOR 4' (1.2 m) WIDE MEDIANS	SOLID	YELLOW; TWO WAY TRAFFIC WHITE; ONE WAY TRAFFIC	11 (280) C-C FOR THE DOUBLE LINE SEE TYPICAL PAINTED MEDIAN MARKING.
GORE MARKING AND CHANNELIZING LINES	8 (200) WITH 12 (300) DIAGONALS @ 45°	SOLID	WHITE	DIAGONALS: 15' (4.5 m) C-C (LESS THAN 30MPH (50 km/h)) 20' (6 m) C-C (30MPH (50 km/h) TO 45MPH (70 km/h)) 30' (9 m) C-C (OVER 45MPH (70 km/h))
RAILROAD CROSSING	24 (600) TRANSVERSE LINES; "RR" 15 6" (1.8 m) LETTERS; 16 (400) LINE FOR "X"	SOLID	WHITE	SEE STATE STANDARD 780001 AREA OF: "R"=3.6 SQ. FT. (0.33 m <sup>2</sup> ) EACH "X"=54.0 SQ. FT. (5.0 m <sup>2</sup> )
SHOULDER DIAGONALS	12 (300) @ 45°	SOLID	WHITE - RIGHT YELLOW - LEFT	50' (15 m) C-C (LESS THAN 30MPH (50 km/h)) 75' (25 m) C-C (30 MPH (50 km/h) TO 45MPH (70 km/h)) 150' (45 m) C-C (OVER 45MPH (70 km/h))

FOR FURTHER DETAILS ON PAVEMENT MARKING REFER TO STANDARD SPECIFICATIONS FOR ROAD AND BRIDGE CONSTRUCTION AND STATE STANDARD 780001.

All dimensions are in inches (millimeters) unless otherwise shown.

FILE NAME = W:\dist\d\22x34\1\13.dgn	USER NAME = gaglienobt	DESIGNED - EVERS	REVISED - T. RAMMACHER 10-27-94
		DRAWN -	REVISED - A. HOUSEH 10-09-96
	PLOT SCALE = 50,000' / IN.	CHECKED -	REVISED - A. HOUSEH 10-17-96
	PLOT DATE = 1/4/2008	DATE - 03-19-90	REVISED - T. RAMMACHER 01-06-00

STATE OF ILLINOIS  
DEPARTMENT OF TRANSPORTATION

DISTRICT ONE		F.A.P. RTE.	SECTION	COUNTY	TOTAL SHEETS	SHEET NO.
TYPICAL PAVEMENT MARKINGS		341	N-4-C-1	KANE	32	26
SCALE: NONE		SHEET NO. 1 OF 1 SHEETS		STA. 179+00 TO STA. 194+00	CONTRACT NO. 60D72	
FED. ROAD DIST. NO. 1 ILLINOIS FED. AID PROJECT						

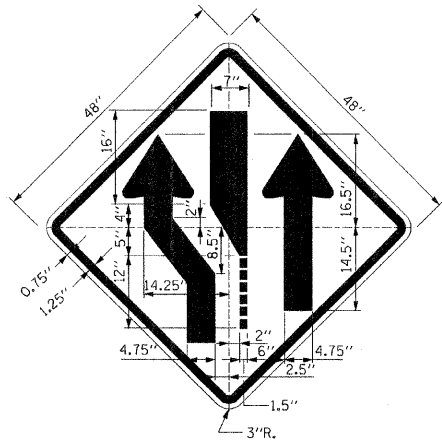

**SIGN TS-1**

COLOR: BACKGROUND - •  
 BORDER AND SYMBOL - BLACK  
 SIZE: 48"x48"  
 MOUNTING HOLES: SAME AS SHOWN FOR SIGN W1-1  
 NOTE: SIGN TS-1L IS SHOWN; REVERSE SYMBOL FOR SIGN TS-1R

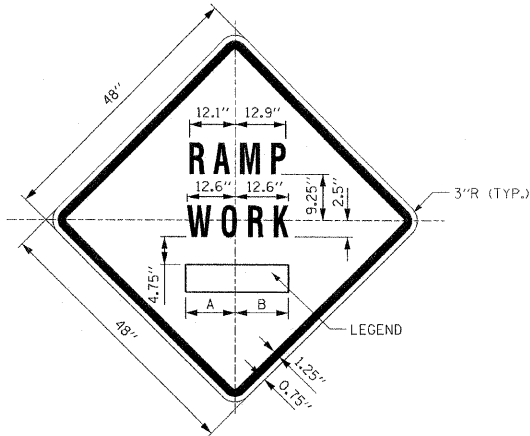

**SIGN TS-2**

COLOR: BACKGROUND - •  
 BORDER AND SYMBOL - BLACK  
 SIZE: 48"x48"  
 LETTERING: 7" FEDERAL SERIES D  
 MOUNTING HOLES: SAME AS SHOWN FOR SIGN W1-1

SIGN NO.	LEGEND	A	B
TS-2A	AHEAD	15.50"	15.50"
TS-2B	500 FT	14.25"	15.13"
TS-2C	1000 FT	14.88" L2	15.75" L2
TS-2D	1500 FT	14.88" L2	15.75" L2
TS-2E	1/2 MILE	15.75" L3	15.75" L3
TS-2F	1 MILE	13.06"	13.06"

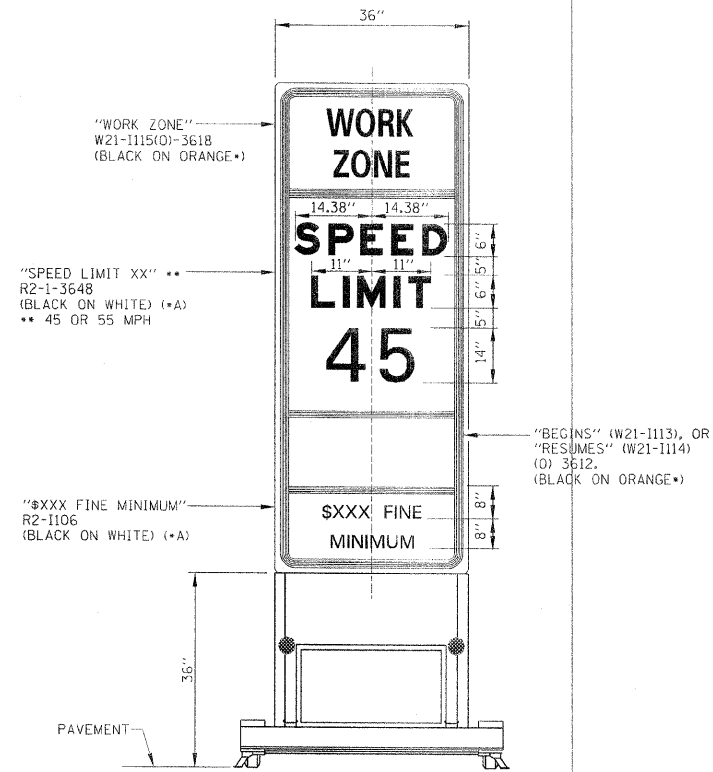

**WORK ZONE SPEED LIMIT SIGN ASSEMBLY**

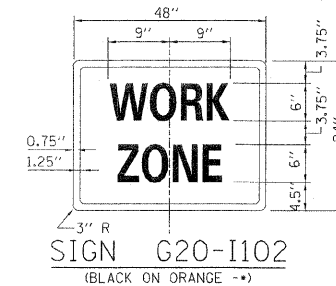

COLOR: BACKGROUND - ORANGE  
 BORDER AND LETTERS - BLACK  
 SIZE: 48"x24"  
 LETTERING: 6" FEDERAL SERIES C,  
 MOUNTING HOLES: 3/8" DIA., 4 HOLES SPACED AS SHOWN ON SIGN G20-2A

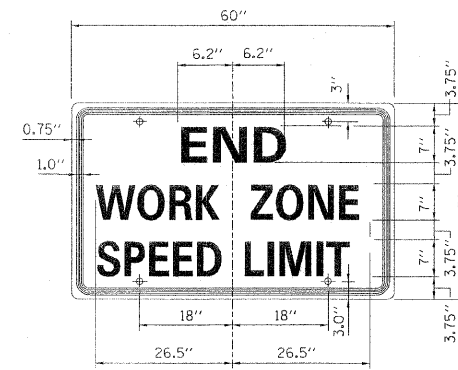

COLOR: BACKGROUND - ORANGE  
 BORDER AND LETTERS - BLACK  
 SIZE: 60"x36"  
 LETTERING: 6" FEDERAL SERIES C,  
 MOUNTING HOLES: 3/8" DIA., 4 HOLES SPACED AS SHOWN

A	4 1/2"
B	5 3/4"
C	12 1/2"
D	7 3/4"
E	6 1/2"
F	4 1/2"
G	6 1/2"
H	6"
I	12 3/4"
J	12"
K	45°
L	55°
M	0 3/4"
N1	2"
N2	6 1/2"

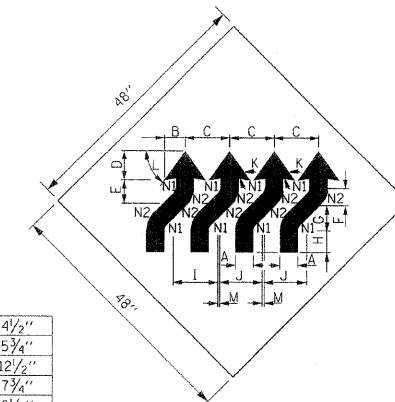

**SIGN WI-4dR**

COLOR: BACKGROUND FLUORESCENT ORANGE TYPE A REFLECTIVE SHEETING PER STANDARD SPECIFICATIONS  
 BORDER AND LETTERS-BLACK  
 SIZE: 48"x48"

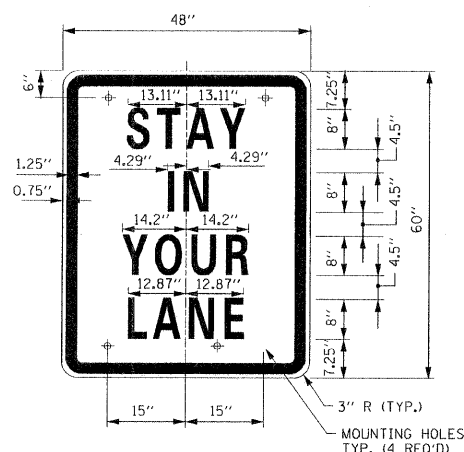

**SIGN TS-3**

COLOR: BACKGROUND - WHITE (REFLECTORIZED)(•A)  
 BORDER AND LETTERS - BLACK  
 SIZE: 48"x60"  
 LETTERING: LEGEND - 8" FEDERAL SERIES D  
 MOUNTING HOLES: 3/8" DIA., 4 HOLES, SPACED AS SHOWN

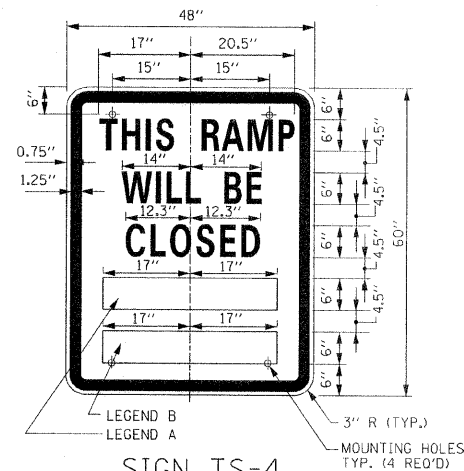

**SIGN TS-4**

COLOR: BACKGROUND - WHITE (REFLECTORIZED)(•A)  
 BORDER AND LETTERS - BLACK  
 SIZE: 48"x60"  
 LETTERING: LEGEND - 6" FEDERAL SERIES C  
 MOUNTING HOLES: 3/8" DIA., 4 HOLES, SPACED AS SHOWN

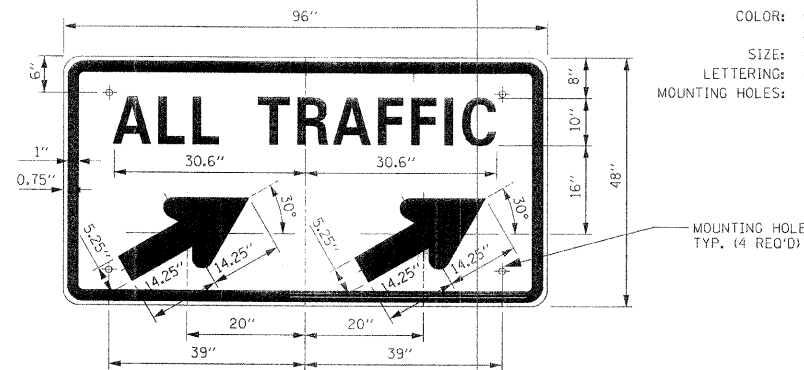

**SIGN TS-5a & TS-5b**

COLOR: BACKGROUND - WHITE (REFLECTORIZED)(•A)  
 BORDER AND LETTERS - BLACK  
 ARROW - BLACK  
 SIZE: 96"x48"  
 LETTERING: 10" FEDERAL SERIES D  
 MOUNTING HOLES: 3/8" DIA., 4 HOLES, SPACED AS SHOWN  
 NOTE: SIGN TS-5a IS SHOWN, SUBSTITUTE LEGEND '✓' FOR '✓' FOR SIGN TS-5b

**NOTES:**

- ALL LETTERING IS DESIGNATED BY SIZE AND SERIES IN ACCORDANCE WITH THE LATEST EDITION OF "STANDARD ALPHABETS FOR HIGHWAY SIGNS AND PAVEMENT MARKINGS" AS PUBLISHED BY THE U.S. DEPARTMENT OF TRANSPORTATION. LETTERING SPACING SHALL BE IN ACCORDANCE WITH THIS GUIDE EXCEPT WHERE NOTED.
- SYMBOLS AND ARROWS SHALL CONFORM TO THE DETAILS SHOWN IN THE LATEST EDITION OF "STANDARD HIGHWAY SIGNS" AS PUBLISHED BY THE U.S. DEPARTMENT OF TRANSPORTATION.
- SEE THE CONTRACT REQUIREMENTS FOR ADDITIONAL NOTES AND SPECIFICATIONS. • - FLUORESCENT ORANGE REFLECTIVE SHEETING PER THE STANDARD SPECIFICATIONS. (•A) - REFLECTIVE SHEETING PER THE STANDARD SPECIFICATIONS.
- DIMENSIONS INDICATED THUS L ARE BASED ON A REDUCTION IN STANDARD LETTERING SPACING AS SHOWN BELOW:  
 L1 SPACING REDUCED BY 25%  
 L2 SPACING REDUCED BY 40%  
 L3 SPACING REDUCED BY 50%

F.A.P. RTE.	SECTION	COUNTY	TOTAL SHEETS	SHEET NO.
341	N-4-C-1	KANE	32	27

CONTRACT 60D72

SHEET 1 OF 2

**Illinois Tollway**  
 Open Roads for a Faster Future

DATE	REVISIONS

CONSTRUCTION SIGNS

STANDARD E1-00

APPROVED: *Jeff Daley*  
 CHIEF ENGINEER DATE 1-1-2007

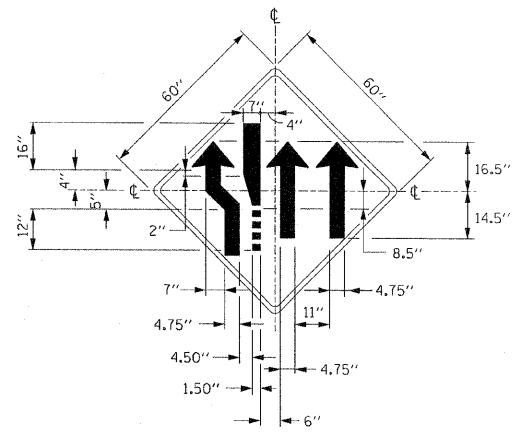

SIGN TS-1CL

COLOR: COLOR - BLACK (NON - REFLECTORIZED)  
 COLOR: BACKGROUND YELLOW (REFLECTORIZED) PERMANENT USAGE  
 \* FLUORESCENT ORANGE CONSTRUCTION USAGE

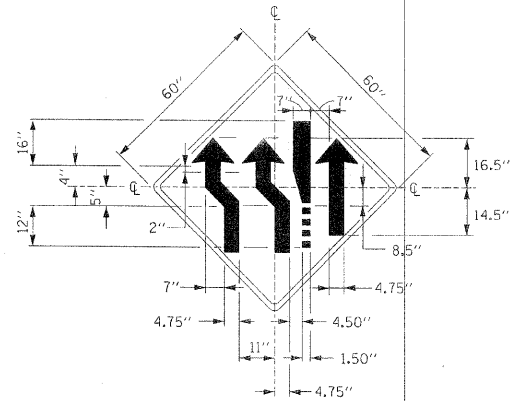

SIGN TS-1CR

COLOR: COLOR - BLACK (NON - REFLECTORIZED)  
 COLOR: BACKGROUND YELLOW (REFLECTORIZED) PERMANENT USAGE  
 \* FLUORESCENT ORANGE CONSTRUCTION USAGE

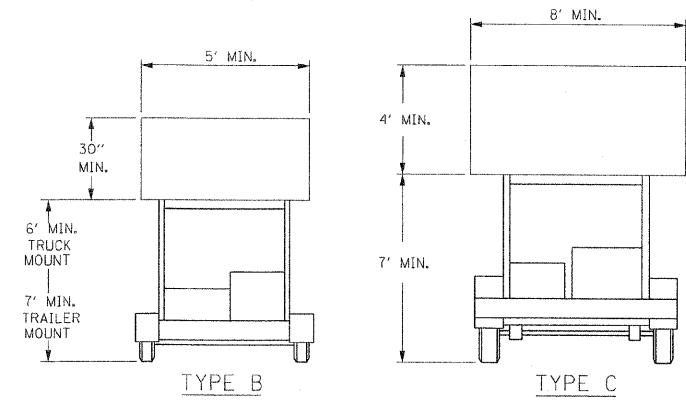

TYPE B TRUCK OR TRAILER MOUNTED  
 TYPE C TRAILER MOUNTED

ARROW BOARDS SHALL BE IN ACCORDANCE WITH THE STANDARD SPECIFICATIONS. TYPE C UNITS ARE TO BE USED FOR ALL OPERATIONS 24 HOURS OR MORE IN DURATION AND TYPE B UNITS MAY BE USED FOR OPERATIONS LESS THAN 24 HOURS IN DURATION. ARROW BOARDS SHALL NOT BE USED TO DIRECT PASSING MOVES INTO LANES USED BY OPPOSING TRAFFIC.

FLASHING ARROW BOARDS  
 SIGN TS-8

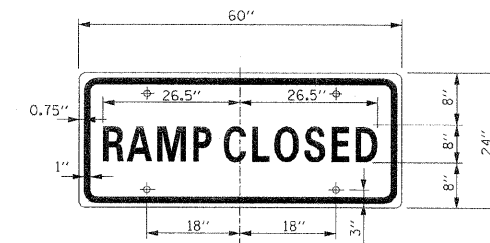

SIGN TS-6

COLOR: BACKGROUND - WHITE (REFLECTORIZED)  
 BORDER AND LETTERS - BLACK  
 SIZE: 60"x24"  
 LETTERING: 8" FEDERAL SERIES C  
 MOUNTING HOLES: 3/16" DIA., 4 HOLES SPACED AS SHOWN

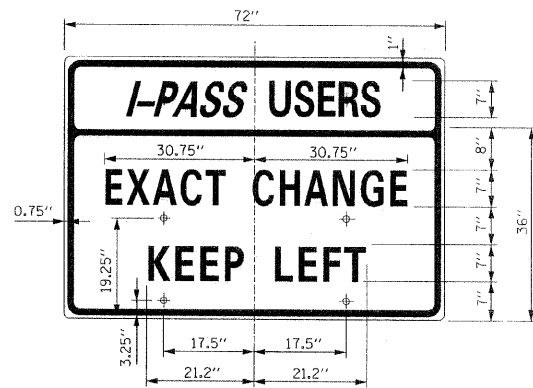

SIGN TS-7

COLOR: BACKGROUND - WHITE (REFLECTORIZED) (\*A)  
 BORDER AND LETTERS - BLACK  
 SIZE: 72"x36"  
 LETTERING: 7" FEDERAL SERIES C  
 MOUNTING HOLES: 7/16" DIA., 4 HOLES SPACED AS SHOWN

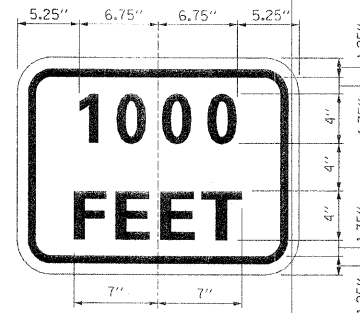

SUPPLEMENTAL PLATE

COLOR: BACKGROUND - \* FLUORESCENT ORANGE  
 BORDER AND LETTERS - BLACK  
 SIZE: 24"x18"  
 LETTERING: 4" FEDERAL SERIES D  
 MOUNTING HOLES: 7/16" DIA.

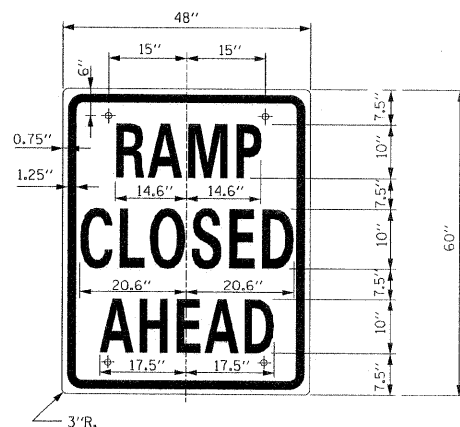

SIGN TS-9

COLOR: BACKGROUND - WHITE (REFLECTORIZED)  
 BORDER AND LETTERS - BLACK  
 SIZE: 48"x60"  
 LETTERING: 10" FEDERAL SERIES C  
 MOUNTING HOLES: 7/16" DIA., 4 HOLES SPACED AS SHOWN

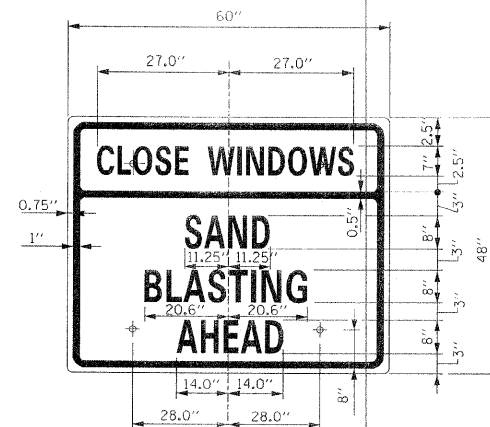

SIGN TS-10

COLOR: BACKGROUND - \* FLUORESCENT ORANGE  
 BORDER AND LETTERS - BLACK  
 SIZE: 60"x48"  
 LETTERING: 8" FEDERAL SERIES C, 7" FEDERAL SERIES B  
 MOUNTING HOLES: 7/16" DIA., 4 HOLES SPACED AS SHOWN

GENERAL NOTES:

- ALL LETTERING IS DESIGNATED BY SIZE AND SERIES IN ACCORDANCE WITH THE LATEST EDITION OF "STANDARD ALPHABETS FOR HIGHWAY SIGNS AND PAVEMENT MARKINGS" AS PUBLISHED BY THE U.S. DEPARTMENT OF TRANSPORTATION. LETTERING SPACING SHALL BE IN ACCORDANCE WITH THE GUIDE EXCEPT WHERE NOTED.
  - SYMBOLS AND ARROWS SHALL CONFORM TO THE DETAILS SHOWN IN THE LATEST EDITION OF "STANDARD HIGHWAY SIGNS" AS PUBLISHED BY THE U.S. DEPARTMENT OF TRANSPORTATION.
  - SEE THE CONTRACT REQUIREMENTS FOR ADDITIONAL NOTES AND SPECIFICATIONS.
- FLUORESCENT ORANGE REFLECTIVE SHEETING PER THE STANDARD SPECIFICATIONS.
  - (\*A) REFLECTIVE SHEETING PER THE STANDARD SPECIFICATIONS.

F.A.P. RTE.	SECTION	COUNTY	TOTAL SHEETS	SHEET NO.
341	N-4-C-1	KANE	32	28
CONTRACT 60D72				



DATE	REVISIONS

CONSTRUCTION SIGNS

STANDARD E1-00

APPROVED: *Jeff Daley*  
 DATE 1-1-2007

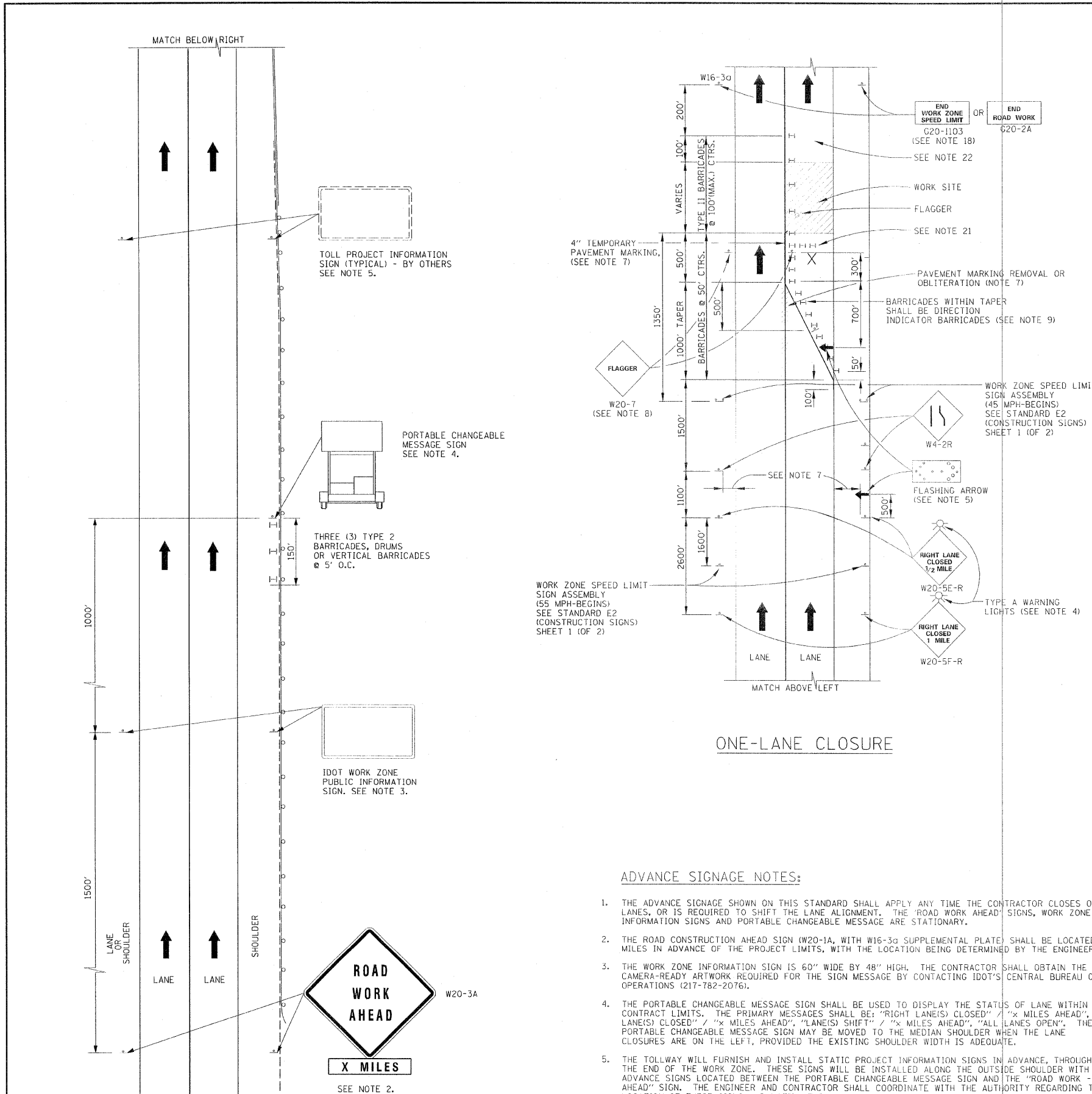

**LANE CLOSURE NOTES:**

- IF CLOSURES ARE EXPECTED TO PRODUCE TRAFFIC BACKUPS EXTENDING BEYOND THE FIRST WARNING SIGN SHOWN ON THE DETAILS, ADDITIONAL UPSTREAM SIGNS SHALL BE PLACED SO THAT THE TRAFFIC CONTROL ZONE ENCOMPASSES THE ANTICIPATED BACKUP ZONE.
- LONGITUDINAL DIMENSIONS MAY BE ADJUSTED SLIGHTLY TO FIT FIELD CONDITIONS.
- THESE DETAILS ALSO APPLY TO OPPOSITE HAND LANE CLOSURES BY CHANGING SIGN LEGENDS AND ARROW DIRECTIONS TO INDICATE THE APPROPRIATE CLOSURE.
- FOR NIGHT TIME CLOSURES, ONE TYPE A WARNING LIGHT SHALL BE INSTALLED ABOVE EACH OF THE 1 MILE AND 1/2 MILE ADVANCE WARNING SIGNS. FOR DAYLIGHT-ONLY CLOSURES, THE LIGHTS MAY BE OMITTED AND A MINIMUM OF 18" X 18" ORANGE WARNING FLAG AFFIXED TO THE FIRST SIGN ONLY.
- FOR ANY LANE CLOSURE, FLASHING ARROW BOARDS SHALL BE REQUIRED AND IN OPERATION AT ALL TIMES. THE FLASHING ARROW BOARD IN ADVANCE OF THE TAPER SHALL BE PROTECTED WITH THREE TYPE II BARRICADES AT 50' O.C.
- CONSTRUCTION SIGNS SHALL GENERALLY BE POST-MOUNTED OR ATTACHED TO PORTABLE SUPPORTS AND SHALL BE INSTALLED 8' TO 12' FROM ADJACENT TRAVEL LANE WHEREVER POSSIBLE. IN NO CASE SHALL SIGNS BE LOCATED TO PROVIDE LESS THAN 2' CLEARANCE BETWEEN EDGE OF SIGN AND ADJACENT TRAVEL LANE.
- PAVEMENT MARKING TAPE AND REMOVAL OR OBLITERATION OF EXISTING MARKINGS SHALL BE REQUIRED WHEN THE CLOSURE TIME EXCEEDS FOUR DAYS. THIS WORK SHALL BE MEASURED AND PAID FOR SEPARATELY.
- WHEN A FLAGGER IS NOT ON STATION, THE FLAGGER AHEAD SIGN SHALL BE PROMPTLY REMOVED, COVERED OR TURNED TO FACE AWAY FROM TRAFFIC. SEE NOTE 12 REGARDING MOVING OPERATIONS.
- DIRECTION INDICATOR BARRICADES SHALL BE USED IN LANE TAPERS.
- FOR CLOSURES OTHER THAN SHORT TERM (SUNRISE TO ONE HOUR BEFORE SUNSET), THE MINIMUM HEIGHT OF THE SIGN FROM SHOULDER ELEVATION SHALL BE 7'-0".
- CONES MAY BE USED IN LIEU OF BARRICADES IN THE BUFFER AND WORK AREAS, WHEN THE CLOSURE IS FOR MAINTENANCE OPERATIONS.
- WHENEVER WORKERS ARE PRESENT, ONE WORK ZONE SPEED LIMIT SIGN ASSEMBLY WITH A 45 MPH POSTED SPEED SHALL BE PLACED ADJACENT TO THE OPEN LANE AT A DISTANCE OF 1000' MINIMUM TO 2,500' MAXIMUM IN ADVANCE OF WORKERS THROUGHOUT THE LANE CLOSURE. MOVING OPERATIONS WILL REQUIRE CONTINUOUS ADJUSTMENT OF THE SIGN ASSEMBLY LOCATION TO MAINTAIN THE ABOVE INTERVAL.
- AN ADDITIONAL SIGN ASSEMBLY SHALL BE PLACED 500' BEYOND THE LAST ENTRANCE RAMP FOR EACH INTERCHANGE THAT FALLS WITHIN THE 2,500'.
- THE SIGN ASSEMBLY SHALL BE PLACED NO CLOSER THAN 500' TO ANY OTHER SIGN.
- THE SIGN ASSEMBLY SHALL NOT BE UTILIZED WHEN WORKERS ARE BEHIND A TEMPORARY (MOVABLE BARRIER) WALL.
- THE SIGN ASSEMBLY SHALL BE PROMPTLY REMOVED OR COVERED WHEN WORKERS ARE NOT PRESENT.
- ALL CONFLICTING SPEED LIMIT SIGNS SHALL BE COVERED OR REMOVED.
- SIGNS WITH G20-2A, OR AND G20-1103 SHALL BE IN PLACE WHEN THE SIGN ASSEMBLY (WORK ZONE SPEED LIMIT SIGN) IS UP. THESE SIGNS SHALL ALSO BE REMOVED OR COVERED WHEN THE SIGN ASSEMBLY IS REMOVED OR COVERED, UNLESS STILL REQUIRED BY THE MAINTENANCE OF TRAFFIC PLAN.
- BARRICADES ARE TO BE LOCATED AT JOINT LINE WHEN WORK AREA EXTENDS UP TO JOINT UNLESS OTHERWISE SHOWN ON THE PLANS.
- SEE MAINTENANCE OF TRAFFIC DRAWINGS FOR ADDITIONAL SIGNING IN THIS AREA.
- PLACE CHECK BARRICADES IN ACCORDANCE WITH THE STANDARD SPECIFICATIONS.
- WHEN THE CLOSURE EXTENDS A MINIMUM 2000 FEET PAST THE LAST WORKER, AND THE WIDTH OF THE OPEN LANES HAVE NOT BEEN ALTERED, A WORK ZONE SPEED LIMIT SIGN ASSEMBLY (55-RESUMES) SHALL BE PLACED AT 1/2 MILE INTERVALS UNTIL THE END OF THE CLOSURE, OR THE NEXT WORK OPERATION.

**ADVANCE SIGNAGE NOTES:**

- THE ADVANCE SIGNAGE SHOWN ON THIS STANDARD SHALL APPLY ANY TIME THE CONTRACTOR CLOSES ONE OR MORE LANES, OR IS REQUIRED TO SHIFT THE LANE ALIGNMENT. THE 'ROAD WORK AHEAD' SIGNS, WORK ZONE PUBLIC INFORMATION SIGNS AND PORTABLE CHANGEABLE MESSAGE ARE STATIONARY.
- THE ROAD CONSTRUCTION AHEAD SIGN (W20-1A, WITH W16-3a SUPPLEMENTAL PLATE) SHALL BE LOCATED UP TO 5 MILES IN ADVANCE OF THE PROJECT LIMITS, WITH THE LOCATION BEING DETERMINED BY THE ENGINEER.
- THE WORK ZONE INFORMATION SIGN IS 60" WIDE BY 48" HIGH. THE CONTRACTOR SHALL OBTAIN THE CAMERA-READY ARTWORK REQUIRED FOR THE SIGN MESSAGE BY CONTACTING IDOT'S CENTRAL BUREAU OF OPERATIONS (217-782-2076).
- THE PORTABLE CHANGEABLE MESSAGE SIGN SHALL BE USED TO DISPLAY THE STATUS OF LANE WITHIN THE CONTRACT LIMITS. THE PRIMARY MESSAGES SHALL BE: "RIGHT LANE(S) CLOSED" / "X MILES AHEAD", "LEFT LANE(S) CLOSED" / "X MILES AHEAD", "LANE(S) SHIFT" / "X MILES AHEAD", "ALL LANES OPEN". THE PORTABLE CHANGEABLE MESSAGE SIGN MAY BE MOVED TO THE MEDIAN SHOULDER WHEN THE LANE CLOSURES ARE ON THE LEFT, PROVIDED THE EXISTING SHOULDER WIDTH IS ADEQUATE.
- THE TOLLWAY WILL FURNISH AND INSTALL STATIC PROJECT INFORMATION SIGNS IN ADVANCE, THROUGH AND AT THE END OF THE WORK ZONE. THESE SIGNS WILL BE INSTALLED ALONG THE OUTSIDE SHOULDER WITH THE ADVANCE SIGNS LOCATED BETWEEN THE PORTABLE CHANGEABLE MESSAGE SIGN AND THE "ROAD WORK - 1 MILE AHEAD" SIGN. THE ENGINEER AND CONTRACTOR SHALL COORDINATE WITH THE AUTHORITY REGARDING THE LOCATION OF THESE SIGNS AND NOTIFY THE AUTHORITY OF ANY DAMAGE TO THE SIGNS OR SUPPORTS.

F.A.P. RTE.	SECTION	COUNTY	TOTAL SHEETS	SHEET NO.
341	N-4-C-1	KANE	32	29

CONTRACT 60D72



DATE	REVISIONS

LANE CLOSURE DETAILS

STANDARD E2-00

APPROVED: *Jeff Daley* DATE 1-1-2007

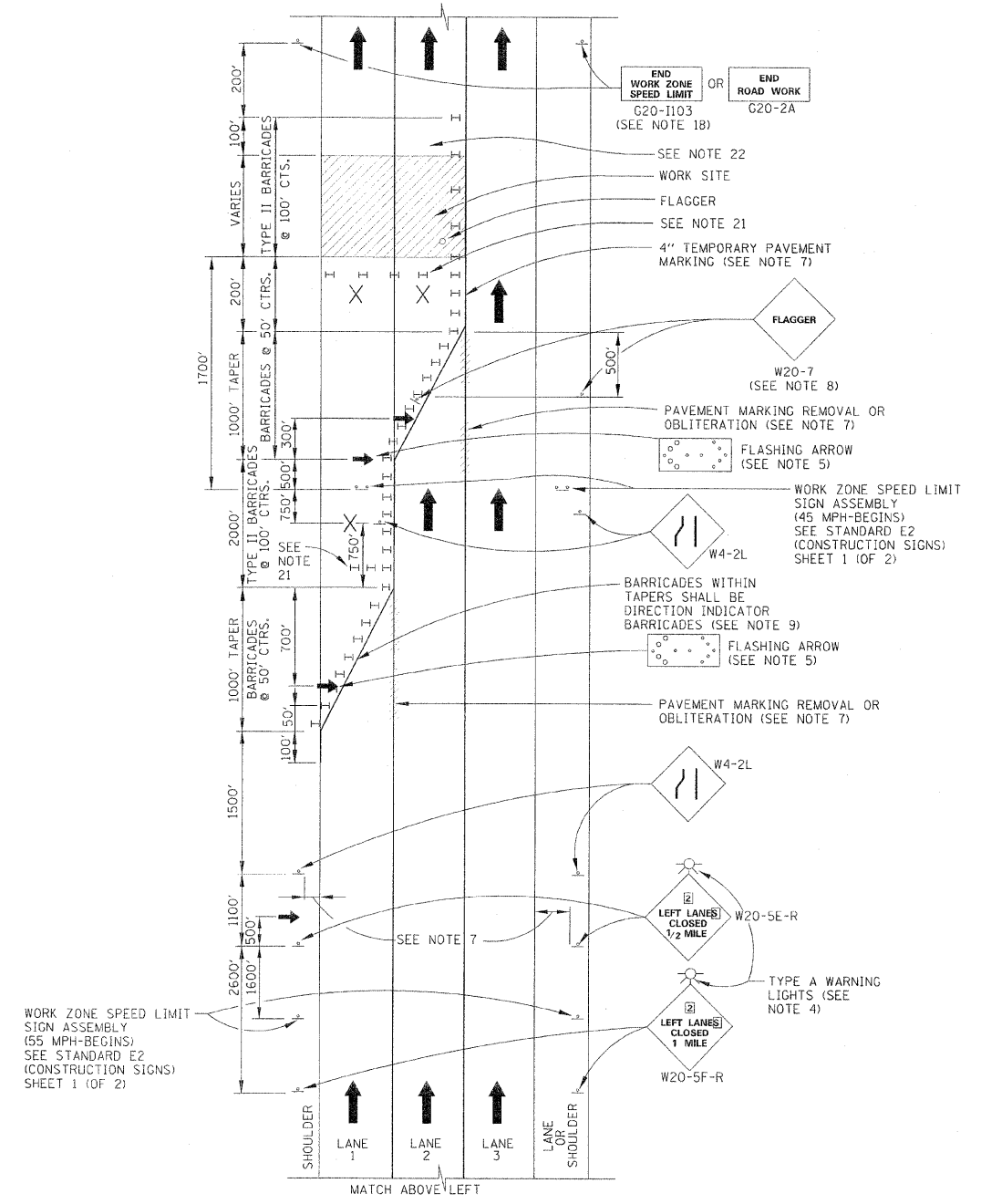
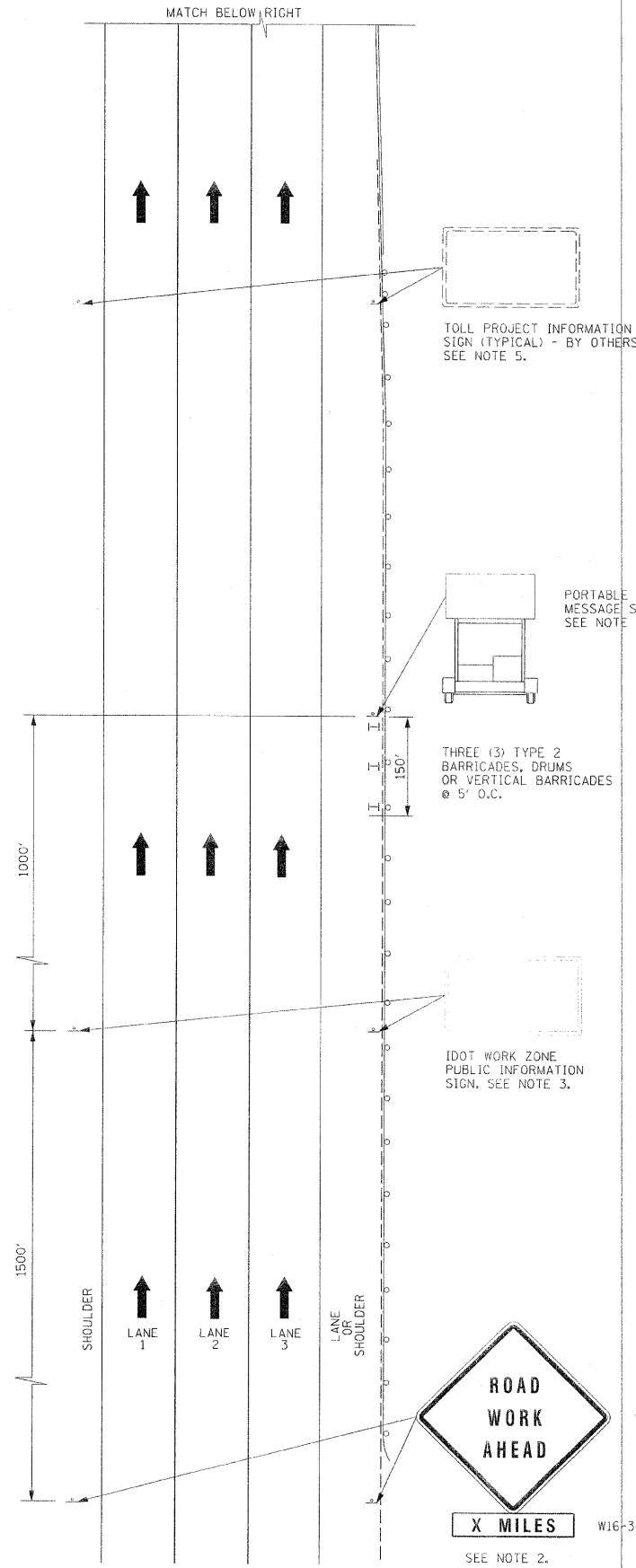

TWO-LANE CLOSURE

F.A.P. RTE.	SECTION	COUNTY	TOTAL SHEETS	SHEET NO.
341	N-4-C-1	KANE	32	30
CONTRACT 60D72				



LANE CLOSURE DETAILS

STANDARD E2-00

DATE	REVISIONS

SEE SHEET 1 (OF 3) IN THIS SERIES FOR GENERAL NOTES

APPROVED: *Jeff Daley* DATE 1-1-2007

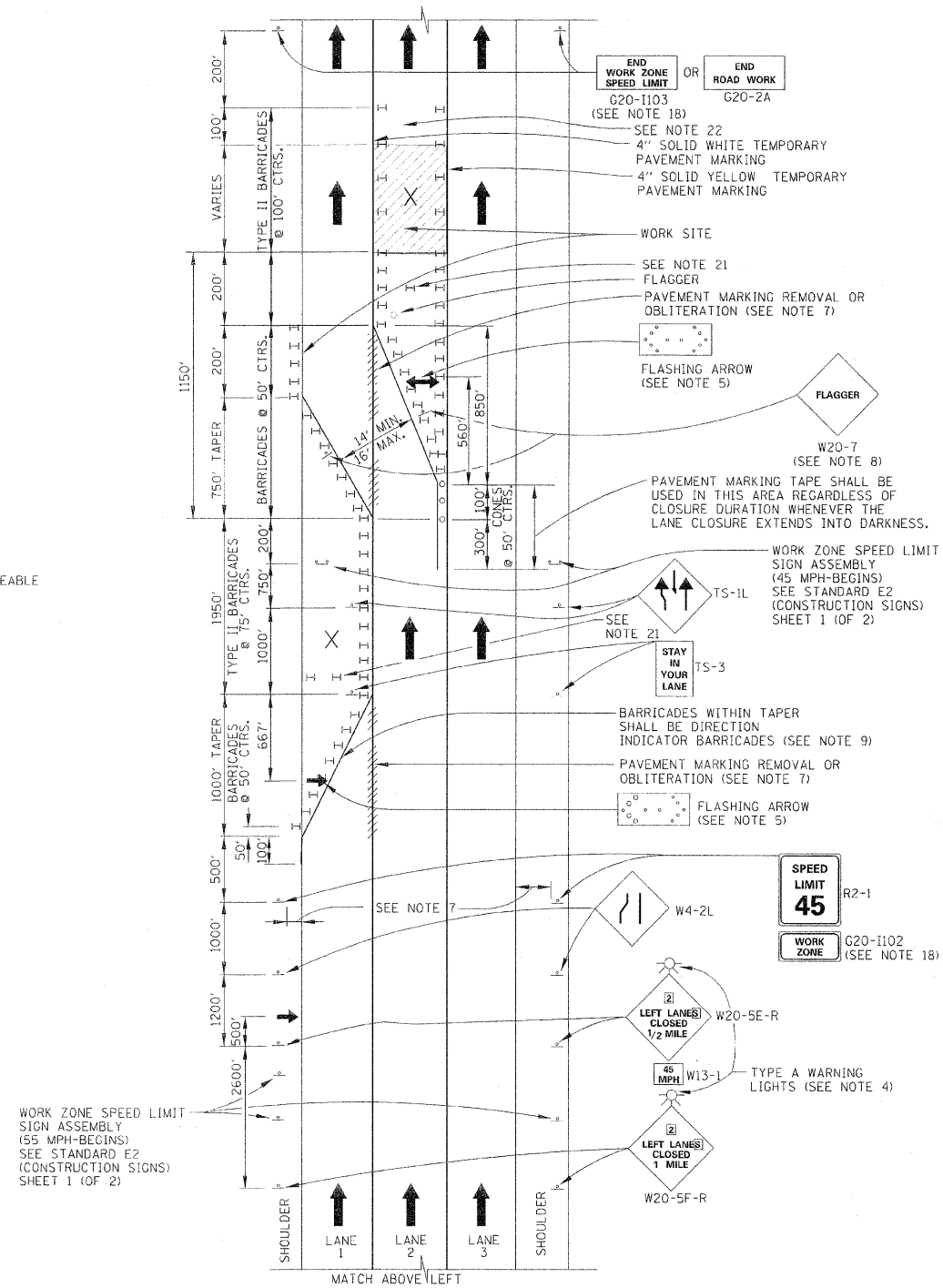
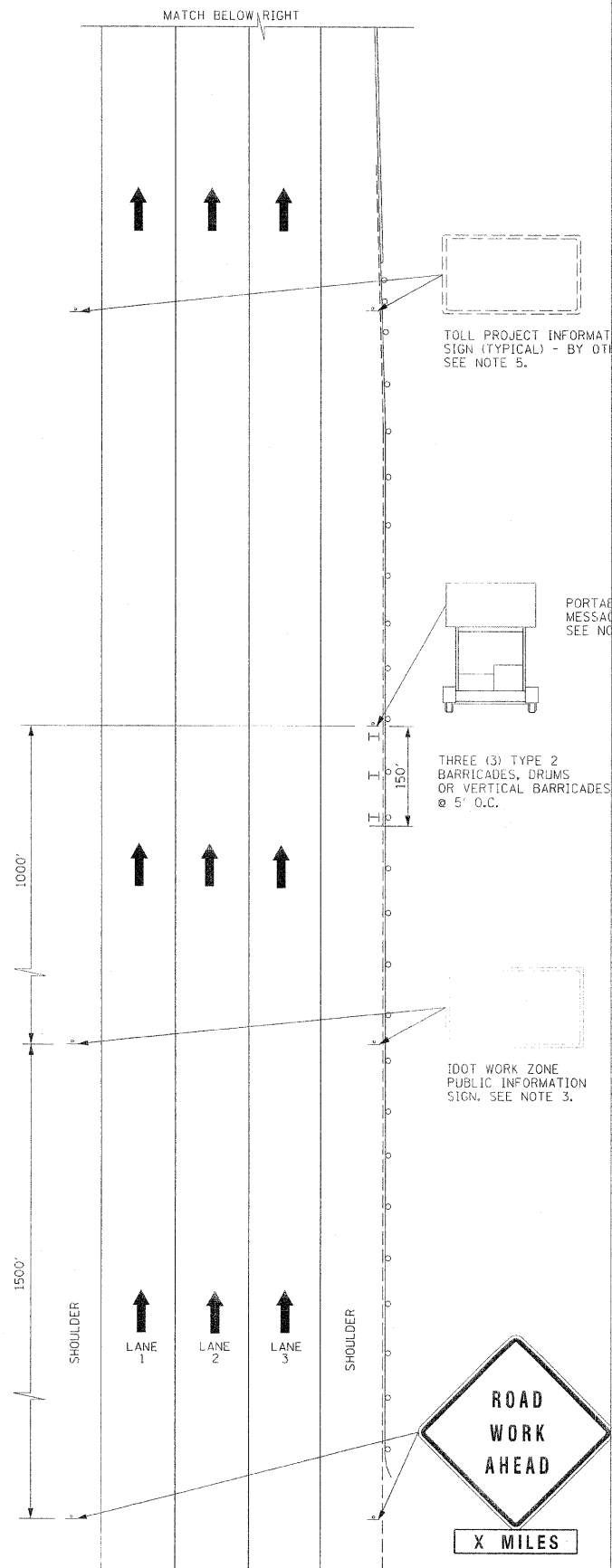

P.A.P. RTE.	SECTION	COUNTY	TOTAL SHEETS	SHEET NO.
341	N-4-C-1	KANE	32	31

CONTRACT 60D72

SHEET 3 OF 3

**Illinois Tollway**  
Open Roads for a Faster Future

LANE CLOSURE DETAILS

STANDARD E2-00

DATE	REVISIONS

SEE SHEET 1 (OF 3) IN THIS SERIES FOR GENERAL NOTES

APPROVED *Jeff Daley* DATE 1-1-2007

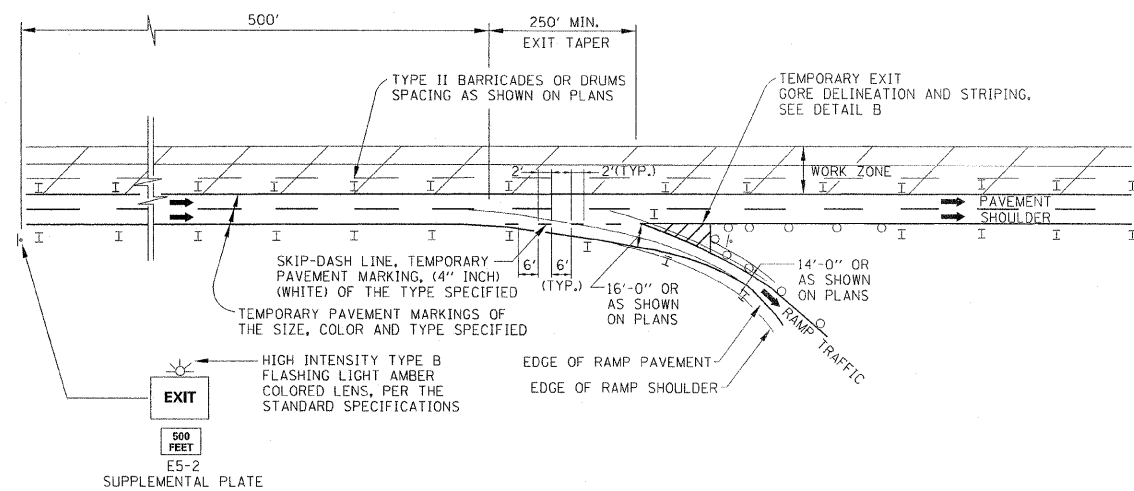

TYPICAL APPLICATION OF TEMPORARY EXIT GORE DELINEATION AND SIGNING

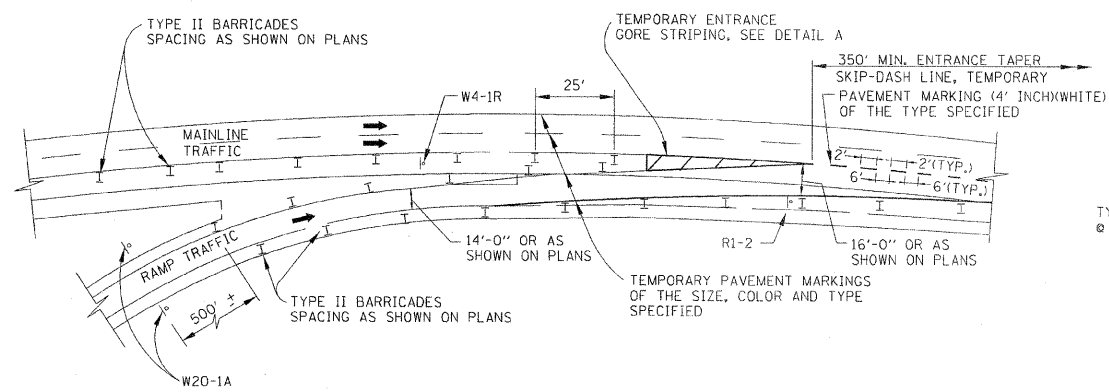

TYPICAL APPLICATION OF TEMPORARY ENTRANCE GORE DELINEATION AND SIGNING

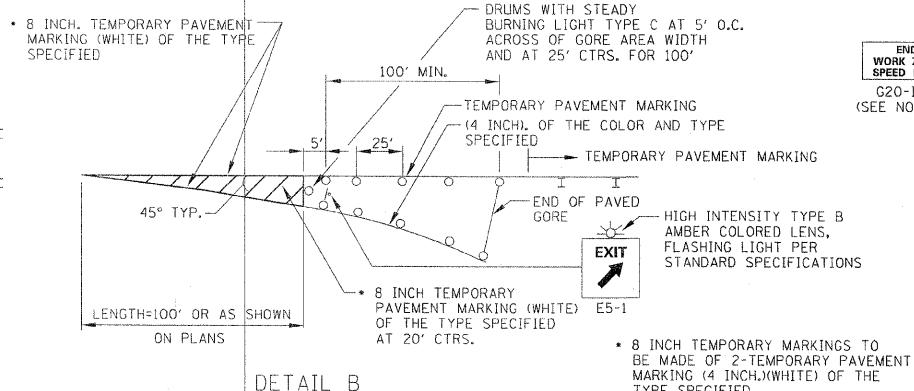

DETAIL B  
TEMPORARY EXIT GORE DELINEATION AND SIGNING

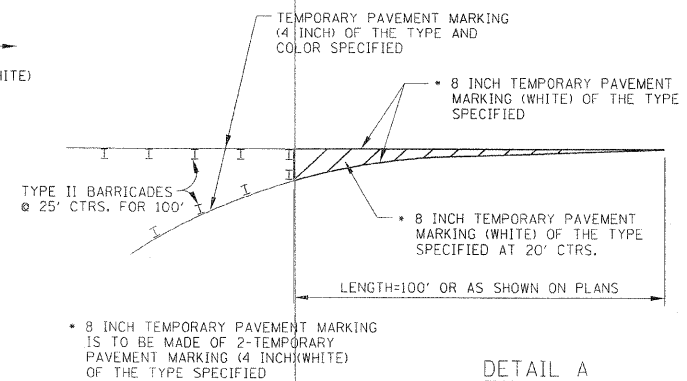

DETAIL A  
TEMPORARY ENTRANCE GORE STRIPING

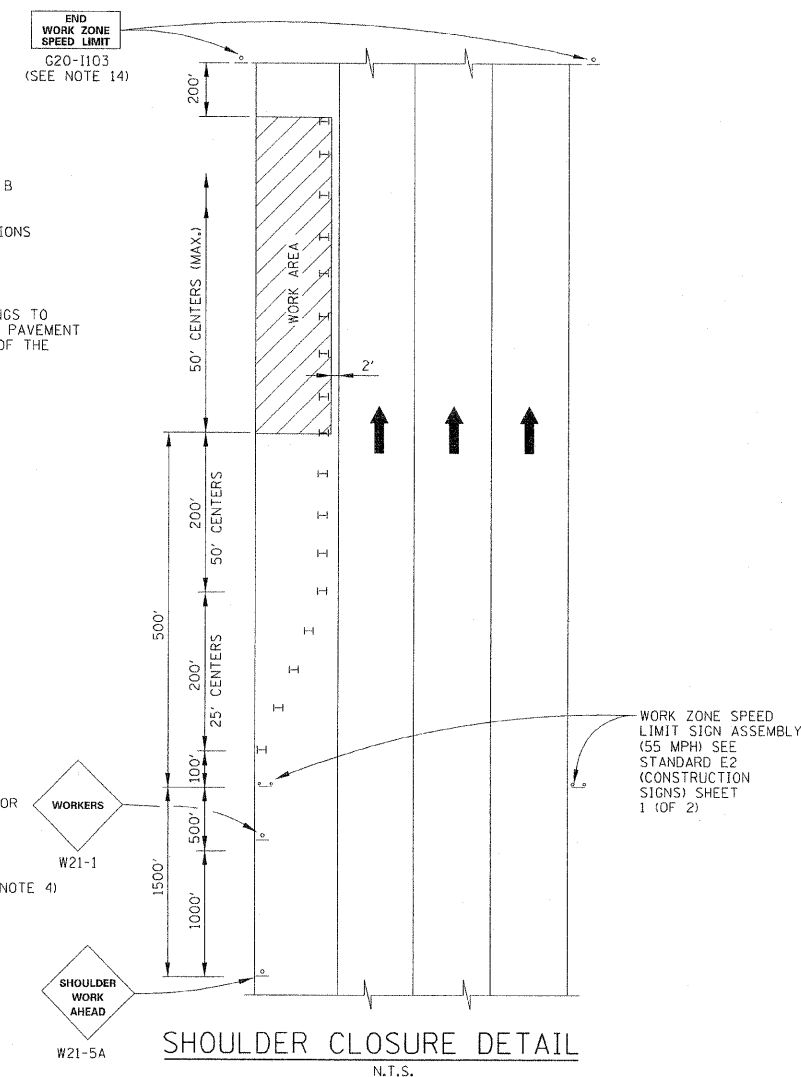

SHOULDER CLOSURE DETAIL  
N.T.S.

GENERAL NOTES:

1. THE SHOULDER SHALL BE CLOSED WHEN A WORK ACTIVITY REQUIRING 15 OR MORE MINUTES IS PERFORMED AT A DISTANCE WHICH IS LESS THAN 15 FEET BUT NO CLOSER THAN 2 FEET THE EDGE OF PAVEMENT.
2. THE ADJACENT EXTERIOR LANE SHALL BE CLOSED WHEN WORK IS PERFORMED WITHIN 2 FEET FROM THE EDGE OF PAVEMENT.
3. THE CHANNELIZING DEVICES WHICH SEPARATE THE WORK SPACE FROM THE ADJACENT TRAVEL LANE SHALL BE SPACED AT 25' FOR THE NINE DEVICES (200 FEET) AND AT A MAXIMUM OF 50' FOR ALL ADDITIONAL DEVICES.
4. WHEN THE WORKSITE IS UNATTENDED, SUBSTITUTE - "SHOULDER WORK AHEAD" SIGN FOR THE SECOND SIGN.
5. WORKER SIGNS OR SHOULDER WORK SIGNS AND CHANNELIZATION DEVICES ARE PLACED ONLY ON THE SIDE OF THE ROADWAY ON WHICH THE ACTIVITY IS PERFORMED.
6. FOR SHOULDER CLOSURE EXTENDING OVERNIGHT, BARRICADE TYPE II WITH STEADY BURNING LIGHT, TYPE C SHALL BE USED.
7. FOR SHORT TERM CLOSURE (SUNRISE TO ONE HOUR BEFORE SUNSET) NOT EXTENDING INTO DARKNESS, CONES MAY BE USED.
8. ONE WORK ZONE SPEED LIMIT SIGN ASSEMBLY (55 MPH - BEGINS) SHALL BE PLACED AT A DISTANCE OF 500' TO 2,500' MAXIMUM IN ADVANCE OF WORKERS THROUGHOUT THE SHOULDER CLOSURE. MOVING OPERATIONS MAY REQUIRE CONTINUOUS ADJUSTMENT OF THE SIGN ASSEMBLY LOCATION TO MAINTAIN THE ABOVE INTERVAL.
9. AN ADDITIONAL SIGN ASSEMBLY SHALL BE PLACED 500' BEYOND THE LAST ENTRANCE RAMP FOR EACH INTERCHANGE THAT FALLS WITHIN THE 2,500'.
10. THE SIGN ASSEMBLY SHALL BE PLACED NO CLOSER THAN 500' TO ANY OTHER SIGN.
11. THE SIGN ASSEMBLY SHALL NOT BE UTILIZED WHEN WORKERS ARE BEHIND A TEMPORARY (MOVABLE BARRIER) WALL.
12. THE WORK ZONE SPEED LIMIT SIGNS AND SIGN ASSEMBLY SHALL BE PROMPTLY REMOVED OR COVERED WHEN WORKERS ARE NOT PRESENT OR CLOSE TO MOVING TRAFFIC.
13. ALL CONFLICTING SPEED LIMIT SIGNS SHALL BE COVERED OR REMOVED.
14. "END WORK ZONE SPEED LIMIT" SIGNS SHALL BE IN PLACE ONLY WHEN THE EXISTING POSTED SPEED > 55MPH.
15. FOR SHOULDER REPAIRS OR REPLACEMENT THE CHANNELIZING DEVICES SHALL BE PLACED AT THE EDGE OF PAVEMENT WHENEVER THE WORK ACTIVITIES RESULT IN A DROPOFF AT THE EDGE OF PAVEMENT.

F.A.P. RTE.	SECTION	COUNTY	TOTAL SHEETS	32
341	N-4-C-1	KANE	32	
CONTRACT 60D72				

**Illinois Tollway**  
Open Roads for a Faster Future

DATE	REVISIONS

TEMPORARY GORE DETAILS AND SHOULDER CLOSURE DETAILS  
STANDARD E3-00

APPROVED: *Jeff Daley*  
CHIEF ENGINEER  
DATE: 1-1-2007