

F. A. U. RTE.	SECTION	COUNTY	TOTAL SHEETS	SHEET NO.
348	07-00055-00-LS	COOK	41	39
STA.		TO STA.		
FED. ROAD DIST. NO.	ILLINOIS	FED. AID PROJECT		

CONTRACT #63106

IMPORTANT NOTE:
SIGN POST TO BE LEVELED AS ONE UNIT
USING LEVELING SHIMS IF REQUIRED.

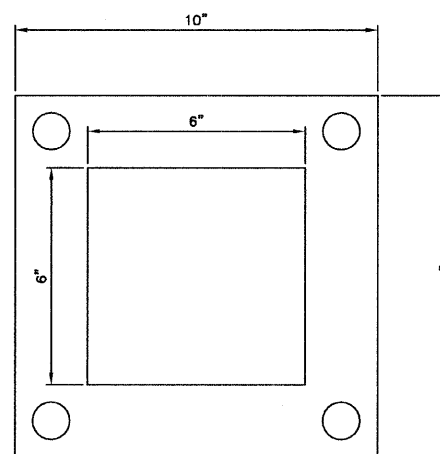
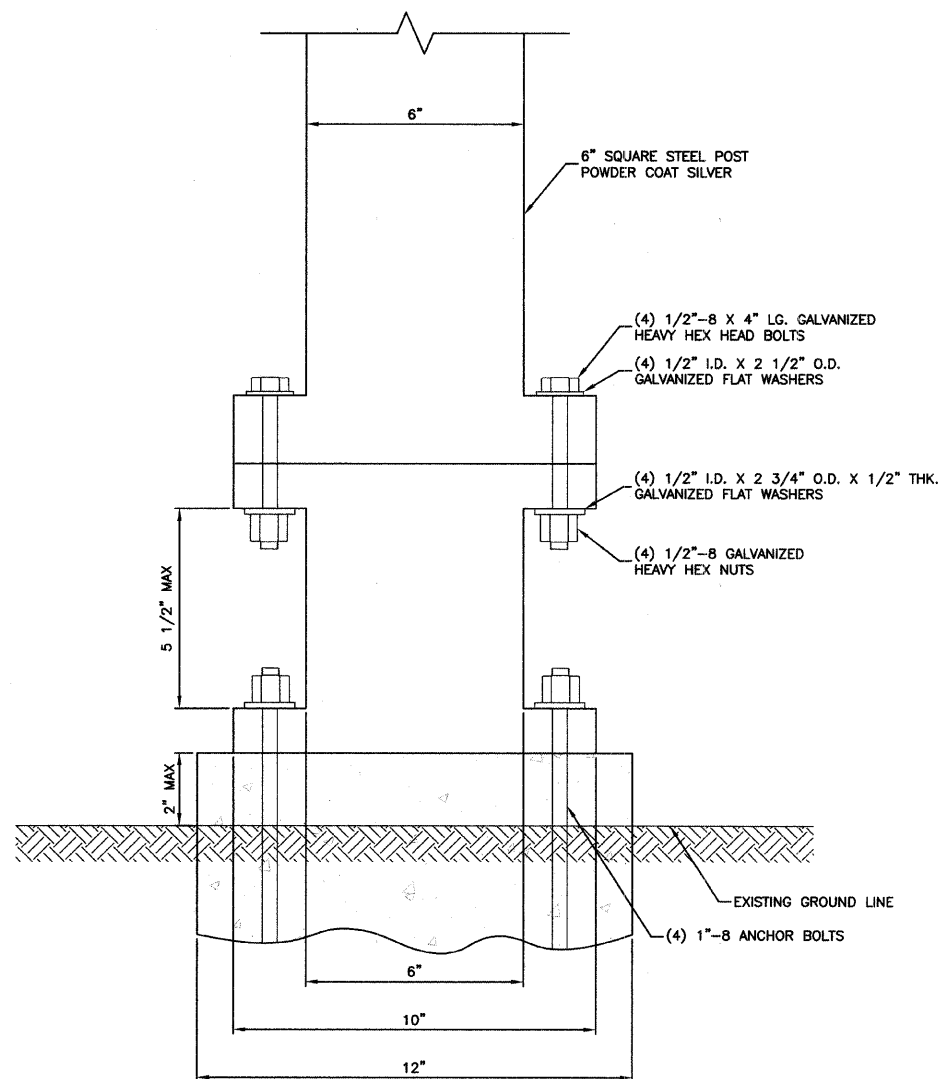

TOP VIEW

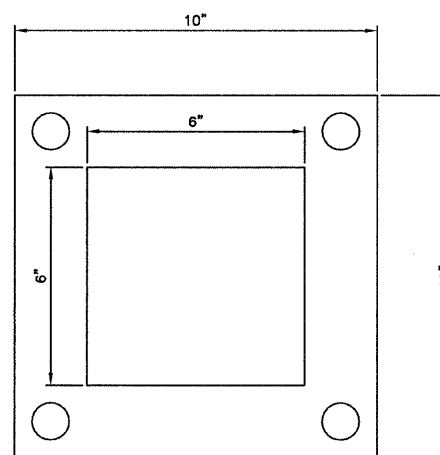

BOTTOM VIEW

NOTE:
BREAK-AWAY MUST BE IDOT APPROVED.

REVISIONS	
NAME	DATE

ILLINOIS DEPARTMENT OF TRANSPORTATION

FAP 348 (HARLEM AVENUE)
SIGN DETAILS

SCALE: VERT. NA
HORIZ. NA
DATE 12-19-08

DRAWN BY LTL
CHECKED BY RJW/PKB

ROBINSON ENGINEERING, LTD.
17001 SOUTH PARK AVENUE, SOUTH HOLLAND, ILLINOIS 60470
(708) 381-8700 FAX (708) 321-0808 07441-LIGHT-01.P01
ILLINOIS DESIGN FIRM REGISTRATION NO. 184001228