

F.A.S. RTE.	SECTION	COUNTY	TOTAL SHEETS	SHEET NO.
674	28 BR	COLES	21	11

**TYPICAL DETAIL OF RURAL PRIVATE AND COMMERCIAL ENTRANCES
ADJACENT TO PROPOSED BITUMINOUS SHOULDERS
(AGGREGATE OR EARTH)**

ALLOWABLE ENTRANCE WIDTHS:

	PRIVATE	COMMERCIAL
MIN.	3.6 m (12')	7.3 m (24')
MAX.	7.3 m (24')	10.7 m (35')

THE ALLOWABLE ENTRANCE WIDTHS SHALL BE INTERPRETED TO BE THE WIDTHS AT THE COMPLETED RADIUS, WHICH MAY BE LOCATED BEHIND THE EXISTING R.O.W. LINE.

** MIN. SLOPE = 1%
MAX. SLOPE = 12%

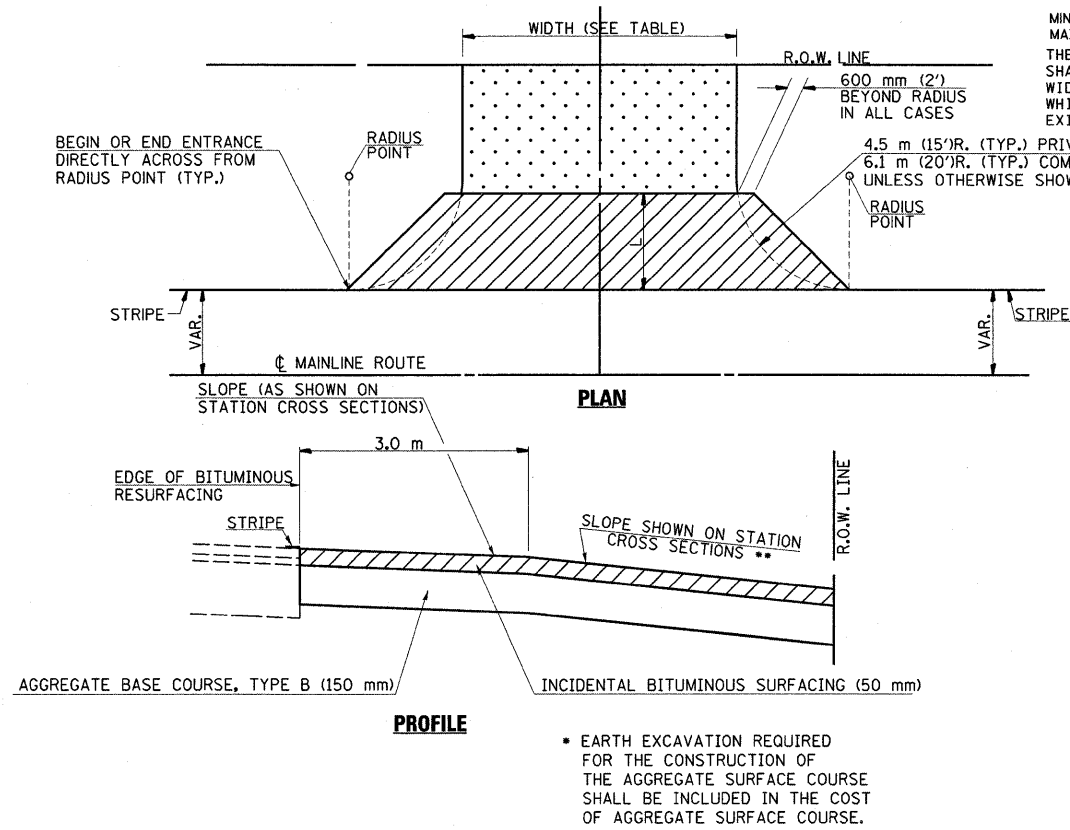

TYPICAL DETAIL OF RURAL MAILBOX TURNOUTS

DISTANCE FROM STRIPE TO BIT. RESURFACING	"D"
300 mm (1.0')	
450 mm (1.5')	
600 mm (2.0')	
750 mm (2.5')	
900 mm (3.0')	

DISTANCE FROM STRIPE TO BIT. RESURFACING	"A"
300 mm (1.0')	
450 mm (1.5')	
600 mm (2.0')	
750 mm (2.5')	
900 mm (3.0')	

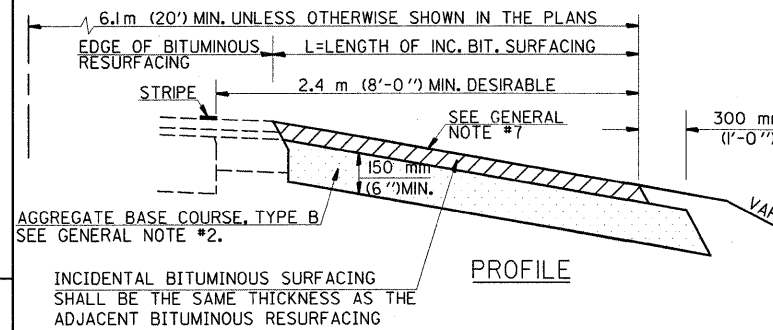
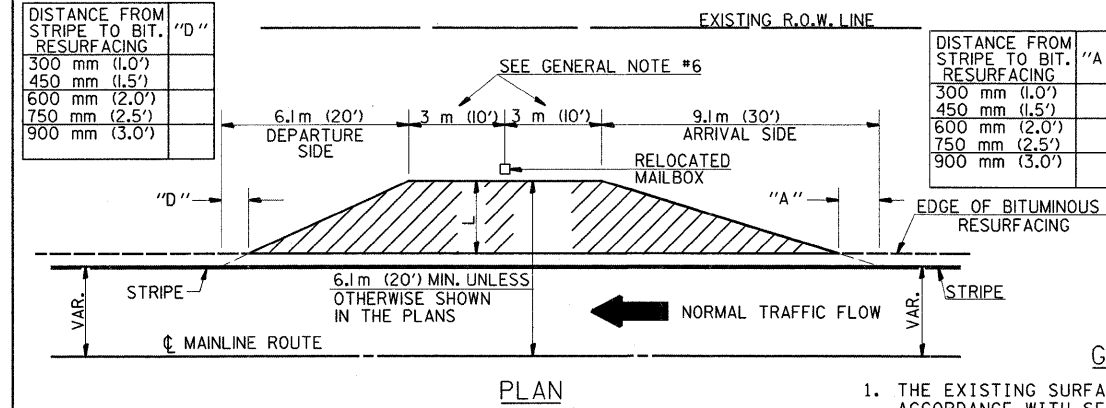

GENERAL NOTES

1. THE EXISTING SURFACE SHALL BE PREPARED IN ACCORDANCE WITH SECTION 408 OF THE STANDARD SPECIFICATIONS.
2. AGGREGATE BASE COURSE, TYPE B OF THE THICKNESS SPECIFIED IN THE PLANS 150 mm (6" MIN.) SHALL BE USED WHERE IN THE OPINION OF THE ENGINEER THERE IS NOT SUFFICIENT BASE MATERIAL FOR THE PROPOSED MAILBOX TURNOUTS. THIS MATERIAL SHALL GENERALLY BE USED TO WIDEN ALL EXISTING MAILBOX TURNOUTS OR TO CONSTRUCT NEW MAILBOX TURNOUTS WHERE NONE NOW EXISTS.
3. THE AGGREGATE BASE COURSE SHALL BE CONSTRUCTED 0.3 m (1') WIDER THAN THE SURFACE DIMENSIONS AS SHOWN ABOVE.
4. ANY NECESSARY WORK BEHIND THE INCIDENTAL BITUMINOUS SURFACING SHALL BE AS SHOWN IN THE PLANS AND/OR AS DIRECTED BY THE ENGINEER.
5. THE TEMPORARY RELOCATION OF EXISTING MAILBOXES SHALL BE IN ACCORDANCE WITH ARTICLE 107.20 (107.19) OF THE STANDARD SPECIFICATIONS.
6. WHEN MORE THAN ONE RELOCATED MAILBOX IS INCLUDED IN A PARTICULAR LOCATION THE TWO 10' DIMENSIONS AS SHOWN ABOVE SHALL BE FROM THE END MAILBOX.
7. CROSS SLOPE SHALL BE AS SHOWN ON THE STATION CROSS SECTIONS AND/OR AS DIRECTED BY THE ENGINEER. MIN. 4% (1/2'') DESIRABLE; MAX. 8% (1'')
8. WHEN MAILBOX TURNOUTS ARE CONSTRUCTED ADJACENT TO FIELD ENTRANCES, THE WIDTH OF THE INCIDENTAL BITUMINOUS SURFACING CONSTRUCTED FOR THE FIELD ENTRANCE SHALL MATCH THE WIDTH OF THE PROPOSED MAILBOX TURNOUT SURFACING.

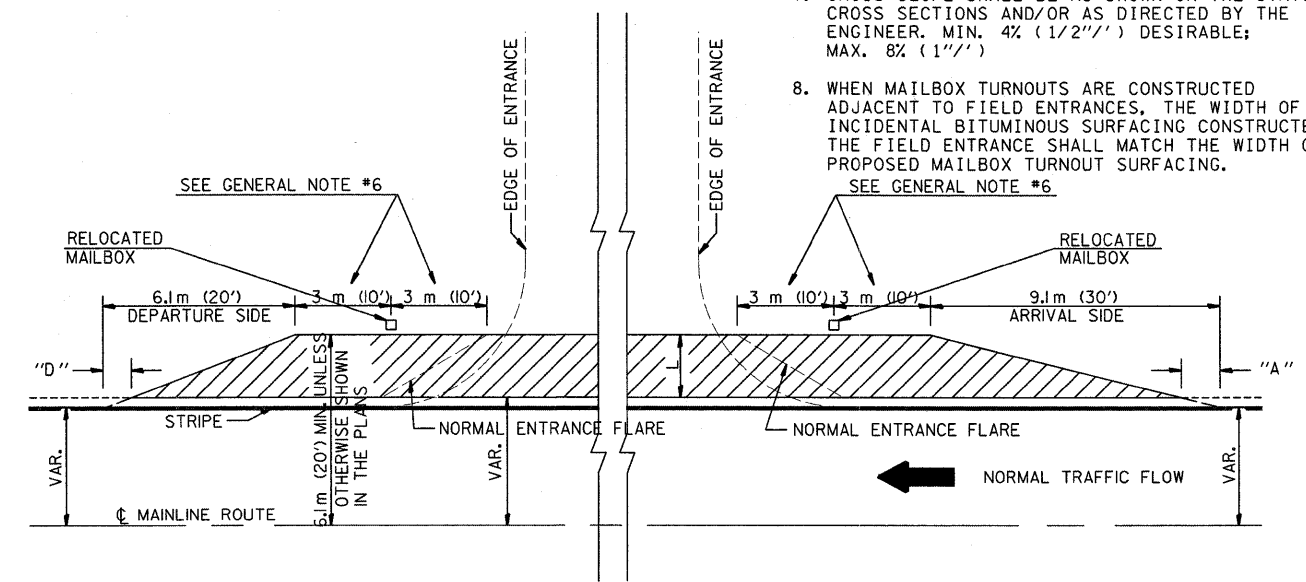

DESIGNED	NAME	DATE	REVISIONS		REVISIONS	
CHECKED	J.M.H.	12/88	NAME	DATE	NAME	DATE
CADD NO.	P.E.K.	12/88	J.M.H.	4/89	D.L.P.	10/96
	C-1.25		J.M.H.	1/92		
			D.L.P.	5/96		