

F.A.I. RTE.	SECTION	COUNTY	TOTAL SHEETS	SHEET NO.
70	60-10K-1,60-10HB	MADISON	420	226
STA.	TO STA.			
FED. ROAD DIST. NO.	ILLINOIS	FED. AID PROJECT		

CONTRACT NO. 76709

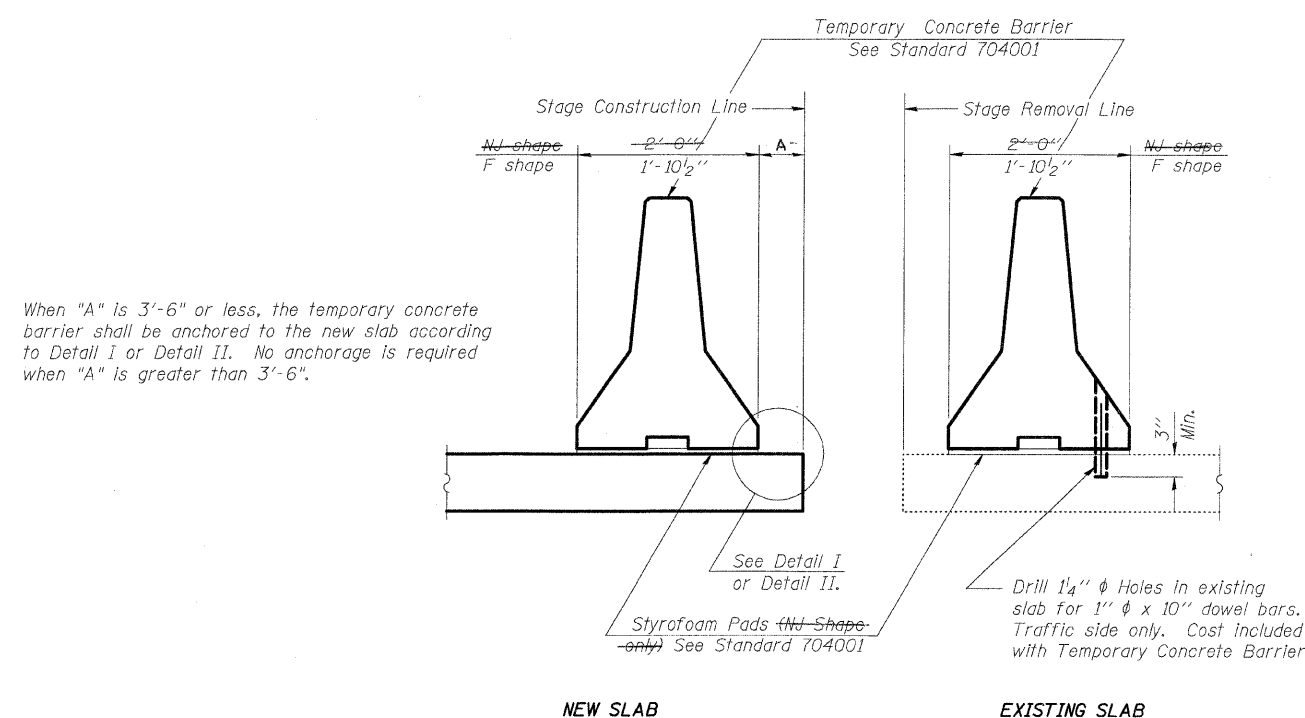

**SECTIONS THRU SLAB**

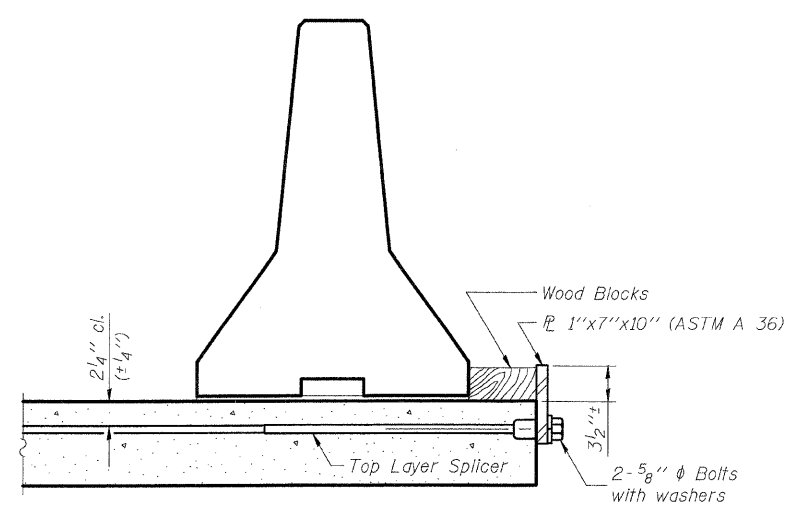

**DETAIL I**  
The 1"x7"x10" Plate shall not be removed until Stage II Construction forms and reinforcement bars are in place.

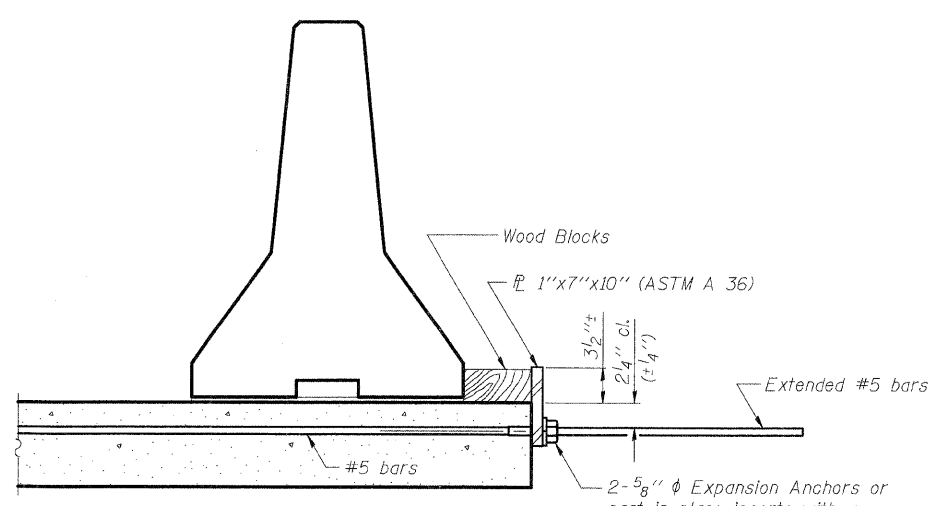

**DETAIL II**  
The 1"x7"x10" Plate shall not be removed until Stage II Construction forms and all reinforcement bars are in place and the concrete is ready to be placed.

**NOTES:**

- Detail I - With Bar Splicer or Couplers:  
Connect one (1) 1"x7"x10" steel  $\bar{P}$  to the top layer of couplers with 2-5/8"  $\phi$  bolts screwed to coupler at approximate  $\bar{C}$  of each barrier panel.
  - Detail II - With Extended Reinforcement Bars:  
Connect one (1) 1"x7"x10" steel  $\bar{P}$  to the concrete slab with 2-5/8"  $\phi$  Expansion Anchors or cast in place inserts spaced between the top layer of reinforcement at approximate  $\bar{C}$  of each barrier panel.
- Cost of anchorage is Included with Temporary Concrete Barrier.  
See civil drawings for Quantity of Temporary Concrete Barrier.

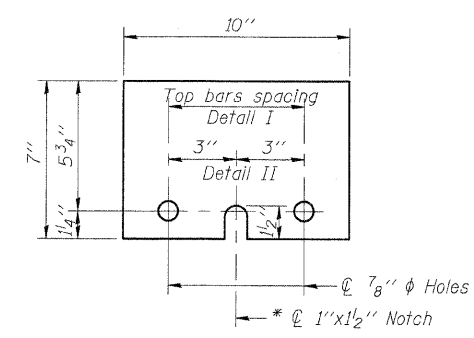

**P 1"x7"x10"**  
\* Required only with Detail II

R-27 9-01-03 (Notes Modified)

SHT. S-08 OF S-68

**STV Incorporated**  
Engineers/Architects/Planners/Construction Managers  
200 W. Monroe Street, Suite 1650  
Chicago, IL 60606-3015  
312.553.0665, FAX 312.553.0661

REVISIONS	
NAME	DATE

ILLINOIS DEPARTMENT OF TRANSPORTATION  
IL ROUTE 162 OVER I-55/70 IN TROY  
F.A.I ROUTE 70 SECTION 60-10K-1, 60-10HB  
MADISON COUNTY STATION 499+48.35  
STRUCTURE NO. 060-0338

**TEMPORARY CONCRETE BARRIER**

DESIGNED: BTO DRAWN: BTO  
DATE: 03/06 CHECKED: JAN CHECKED: JAN