

F.A.I. RTE.	SECTION	COUNTY	TOTAL SHEETS	SHEET NO.
TO	60-10K-1,60-10HB	MADISON	420	268
STA.	TO STA.			
FED. ROAD DIST. NO.	ILLINOIS	FED. AID PROJECT		

CONTRACT NO. 76709

**NOTES:**

- All steel for floating bearings shall conform to the requirements of AASHTO M270 Grade 50, unless otherwise specified.
- Anchor bolts shall be ASTM F1554 allthread (or an Engineer-approved alternate material) Grade 55 of the diameters specified. The corresponding specified grade of AASHTO M314 anchor bolts may be used in lieu of ASTM F1554. Anchor bolts at fixed bearings may be either cast-in-place or installed in holes drilled after the supporting member is in place. Anchor bolts for expansion bearings shall be placed in holes drilled in the concrete through holes in the bottom bearing plate after the members are in place. Drilled and set anchor bolts shall be installed according to Article 521.06 of the Standard Specifications.
- Adjusting shim plates shall be placed under masonry plates as required during erection. See general notes on Sht. S-03.
- The Dimensions shown are for a specific Manufacturer's product. See Special Provision regarding changes to dimensions and details.
- Information not shown regarding the size of the bearing top plate, piston and base assemblies shall be determined by the manufacturer and shall meet the following requirements:  
 Vertical Load Capacity: See Schedule  
 Lateral Load Capacity: See Schedule  
 Rotation from horizontal: 0.02 radians  
 Movement Capacities: See Schedule
- The sliding coefficient of friction shall not exceed 3 percent.
- Certification of compliance to proof load and sliding coefficient of friction requirements in accordance with AASHTO 18.3.5.3 shall be provided with shop drawing submittal.
- The bearings shall be blocked during the erection of structural steel. The Contractor shall submit the Erection Procedure for approval by the Engineer.
- For Design Dead Load and Live Loads, see girder moment tables.
- Work this sheet with sht. S-51.
- For location of bearing type, see Sht. S-37.
- Contractor shall adjust bridge seat elevations and/or shim bearings as required for actual bearing height Th.

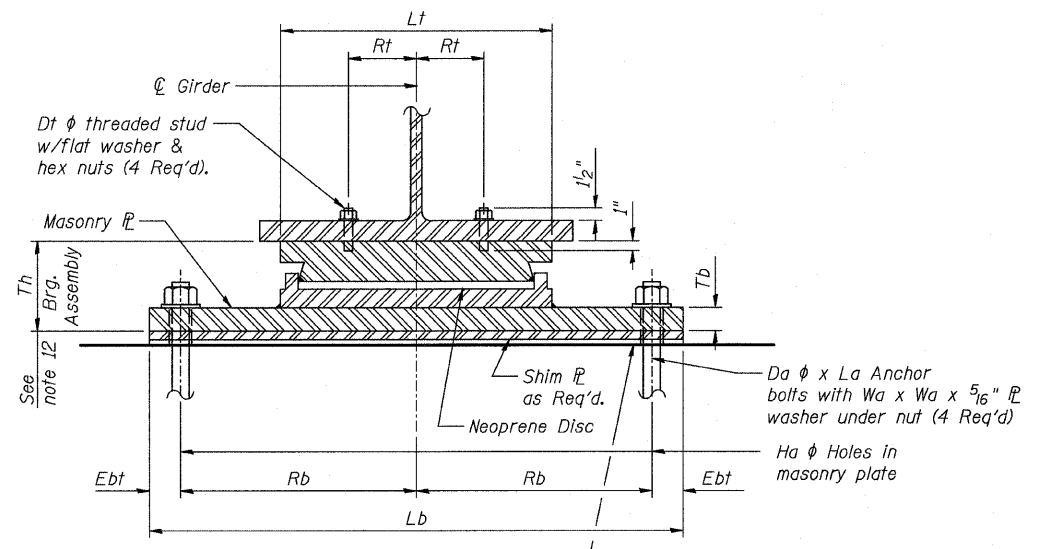

**SECTION**

1/8" Elastomeric neoprene leveling pad according to Art. 1052.02 of the Standard Specifications. Cost included with bearing.

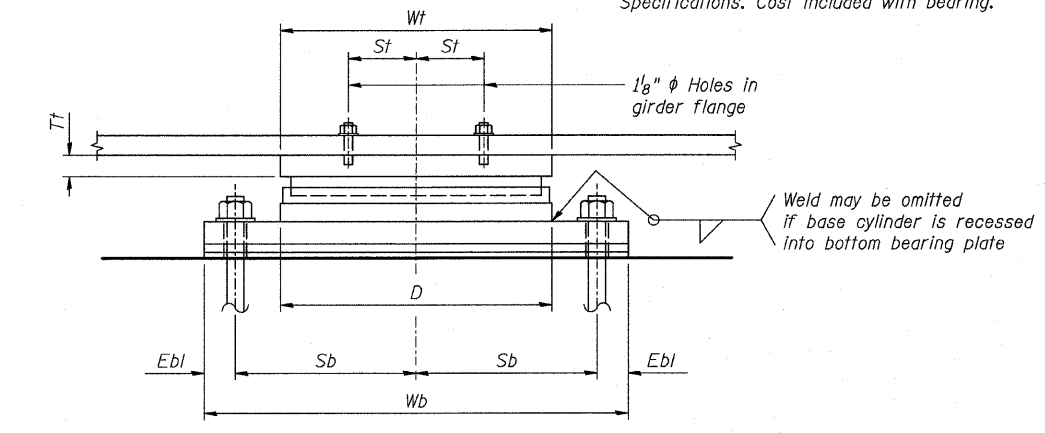

**ELEVATION**

**FIXED BEARING**

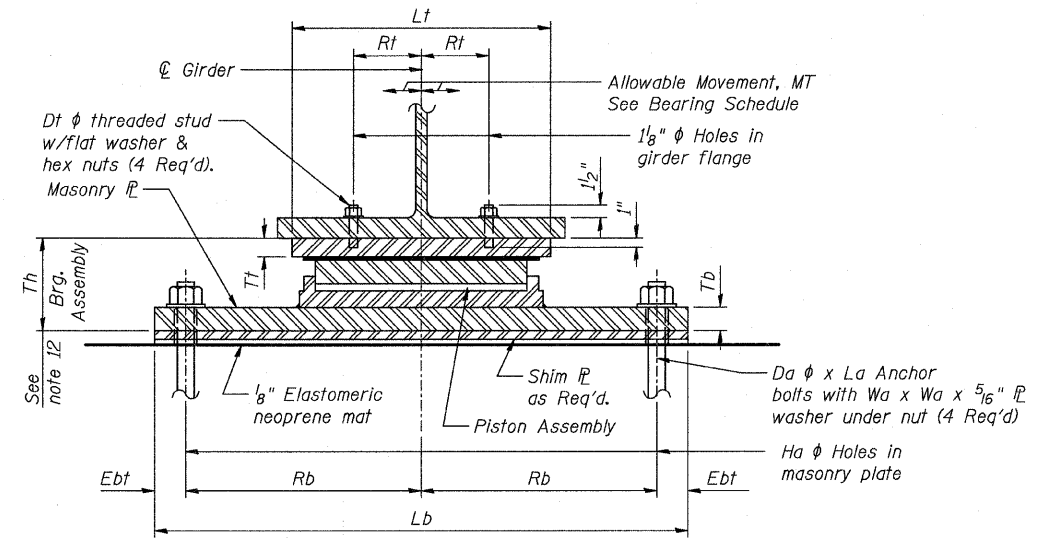

**SECTION**

Allowable Movement, ML See Bearing Schedule

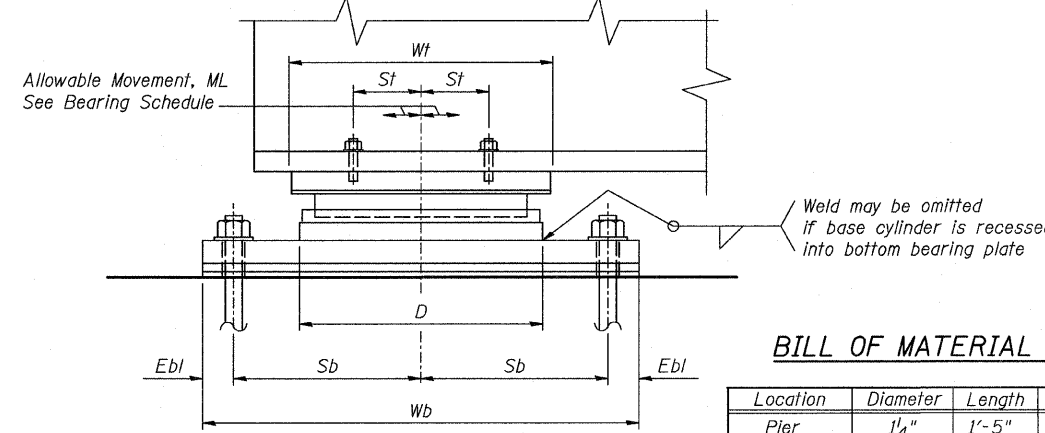

**ELEVATION**

**NON-GUIDED EXPANSION BEARING**

**BILL OF MATERIAL - ANCHORS**

Location	Diameter	Length	Total	Type
Pier	1 1/4"	1'-5"	52	ASTM F1554
E. Abutment	1"	1'-2"	56	ASTM F1554
W. Abutment	1"	1'-2"	64	ASTM F1554

**BILL OF MATERIAL - BEARINGS**

Item	Unit	Total
High Load Multi-Rotation Bearings, Fixed, 250K	Each	13
Floating Bearing, Non-Guided Expansion, 50K	Each	8
Floating Bearing, Non-Guided Expansion, 75K	Each	6
Floating Bearing, Non-Guided Expansion, 100K	Each	6
Floating Bearing, Non-Guided Expansion, 150K	Each	6
Floating Bearing, Non-Guided Expansion, 200K	Each	4

**BEARING SCHEDULE**

Type	Vertical Capacity K	Lateral Capacity K	Quantity Each	Location	Girders	Guided Expansion	ML in	MT in	Th in	D in	Top Plate/Bearing Assembly						Masonry Plate										
											Lt in	Wt in	Dt in	Tt in	St in	Rt in	Lb in	Wb in	Tb in	Sb* in	Rb in	Ebl* in	Ebt in	Da in	La in	Ha in	Wa in
High Load Multi-Rotation Bearings, Fixed, 250K	250	110	13	Pier	3-15	-	-	-	5.75	13.13	13.125	13.125	1	2.375	4.5	4.5	21.50	16.63	1	5.625	8.063	2.688	2.188	1.25	17	1.75	2.75
High Load Multi-Rotation Bearings, Non-Guided Expansion, 50K	50	-	8	Abutment	A1,A2,B1,B2,C1,C2,D1,D2	-	2	0.5	4.75	6.5	6.50	8.75	1	1.5	2.5	2	19	12.25	1	4.375	7.75	1.75	1.75	1	14	1.5	2.25
High Load Multi-Rotation Bearings, Non-Guided Expansion, 75K	75	-	6	Abutment	A3,A4,B3,C3,C4,D3	-	2	0.5	5	7.5	7.50	9.625	1	1.5	3	2	19	13.13	1.25	4.8125	7.75	1.75	1.75	1	14	1.5	2.25
High Load Multi-Rotation Bearings, Non-Guided Expansion, 100K	100	-	6	Abutment	A5,A6,B4,C5,C6,D4	-	2	0.5	5	8.5	8.50	10.5	1	1.5	3	2.25	19	14.0	1.25	5.25	7.75	1.75	1.75	1	14	1.5	2.25
High Load Multi-Rotation Bearings, Non-Guided Expansion, 150K	150	-	6	Abutment	2,16,B5,D5	-	2	0.5	5.25	9.5	9.50	11.125	1	1.5	3.5	2.75	23.5	14.75	1.5	5.625	10	1.75	1.75	1	14	1.5	2.25
High Load Multi-Rotation Bearings, Non-Guided Expansion, 200K	200	-	4	Abutment	1,17	-	2	1	6.1875	12	12	13	1	1.750	4.5	4.00	29.5	16.5	2	6.5	13	1.75	1.75	1	14	1.5	2.25

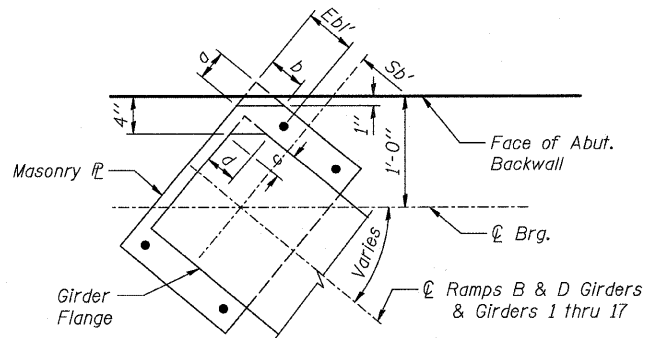

GIRDER	a	b	c	d
B5,D5	3 1/4"	4"	2 9/16"	3 3/8"
B4,D4	3 1/4"	7 3/8"	3 3/8"	1 1/2"
B3,D3	3 3/8"	3 3/8"	3 3/8"	3 3/8"
A5,A6,C5,C6	7 3/8"	7 3/8"	1 1/2"	1 1/2"
A3,A4,C3,C4	2"	2"	3 3/8"	3 3/8"
B1,B2,D1,D2	-	-	-	-
A1,A2,C1,C2	-	-	3 3/8"	3 3/8"
1,17	-	-	5 1/4"	1 1/8"
2,16	-	-	2 1/4"	1 1/2"
3-15	-	-	-	-

**MASONRY PIER & GIRDER FLANGE CORNER CLIP**

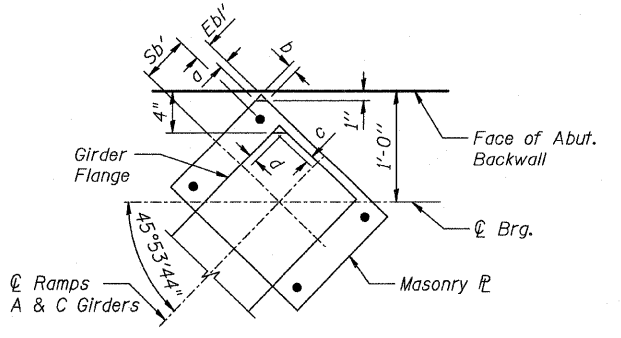

GIRDER	Sb'	Ebl'
B4,D4	4.813"	2.188"
B5,D5	2.063"	5.313"
A5,A6,C5,C6	5.063"	1.938"

\* Dimensions Sb' and Ebl' required due to backwall interference at Abutments. See Masonry Pier & Girder Flange Corner Clip sketches for location of Sb' and Ebl'.

SHT. S-50 OF S-68



REVISIONS	
NAME	DATE

ILLINOIS DEPARTMENT OF TRANSPORTATION  
 IL ROUTE 162 OVER I-55/70 IN TROY  
 F.A.I ROUTE 70 SECTION 60-10K-1, 60-10HB  
 MADISON COUNTY STATION 499+48.35  
 STRUCTURE NO. 060-0338  
 HIGH LOAD MULTI-ROTATION BEARINGS  
 - FIXED AND NON-GUIDED

DESIGNED: BTO DRAWN: BTO  
 CHECKED: JAN CHECKED: JAN  
 DATE: 03/06