

NOTE:
Parapet Stem Height Varies from 2'-0" to 2'-2" at Bridge Approach Parapet.

**BILL OF MATERIAL
RAMP A**

Reinforcing		Bar Length		Shape
Bar	No.	Size	Feet	Inches
a1(E)	647	5	5	9
a2(E)	647	5	4	4
b1(E)	84	5	32	4
b2(E)	70	5	32	3
b3(E)	42	5	32	2
b4(E)	6	5	21	1
b5(E)	5	5	21	0
b6(E)	3	5	20	11
b7(E)	24	5	33	0
b8(E)	20	5	32	11
b9(E)	12	5	32	10
b10(E)	6	5	30	6
b11(E)	5	5	30	5
b12(E)	3	5	30	4
d1(E)	647	5	6	11
d2(E)	647	5	3	10
d3(E)	1,294	5	3	0
e1(E)	28	5	32	2
e2(E)	28	8	34	6
e3(E)	60	4	31	4
e4(E)	2	5	20	11
e5(E)	8	5	32	10
e6(E)	2	8	23	3
e7(E)	8	8	35	2
e8(E)	24	4	29	8
e9(E)	6	4	18	5
e10(E)	18	4	32	0
e11(E)	2	5	30	4
e12(E)	2	8	30	4
e13(E)	12	4	30	4
Reinforcement Bars, Epoxy Coated		Pound	34,750	
Concrete Structures		CU YD	325	
Protective Coat		SQ YD	518	

**BILL OF MATERIAL
RAMP D**

Reinforcing		Bar Length		Shape
Bar	No.	Size	Feet	Inches
a1(E)	596	5	5	9
a2(E)	596	5	4	4
b1(E)	66	5	32	4
b2(E)	55	5	32	3
b3(E)	33	5	32	2
b4(E)	6	5	32	7
b5(E)	5	5	32	6
b6(E)	3	5	32	5
b7(E)	6	5	34	7
b8(E)	5	5	34	6
b9(E)	3	5	34	5
b10(E)	18	5	32	10
b11(E)	15	5	32	9
b12(E)	9	5	32	8
b13(E)	12	5	30	4
b14(E)	10	5	30	3
b15(E)	6	5	30	2
d1(E)	596	5	6	11
d2(E)	596	5	3	10
d3(E)	1,192	5	3	0
e1(E)	22	5	32	2
e2(E)	22	8	34	6
e3(E)	48	4	31	4
e4(E)	2	5	32	10
e5(E)	2	5	34	5
e6(E)	8	5	32	8
e7(E)	2	5	30	2
e8(E)	2	8	35	2
e9(E)	2	8	36	9
e10(E)	8	8	35	0
e11(E)	2	8	30	2
e12(E)	18	4	29	8
e13(E)	6	4	30	4
e14(E)	6	4	33	7
e15(E)	18	4	31	10
e16(E)	12	4	30	2
Reinforcement Bars, Epoxy Coated		Pound	31,940	
Concrete Structures		CU YD	300	
Protective Coat		SQ YD	478	

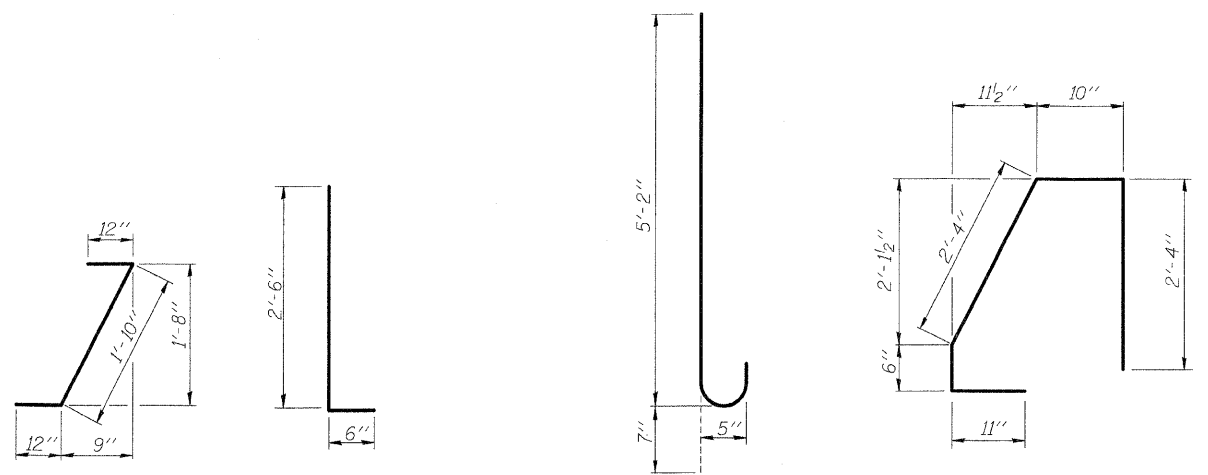

BAR d2(E) **BAR d3(E)** **BAR a1(E)** **BAR d1(E)**

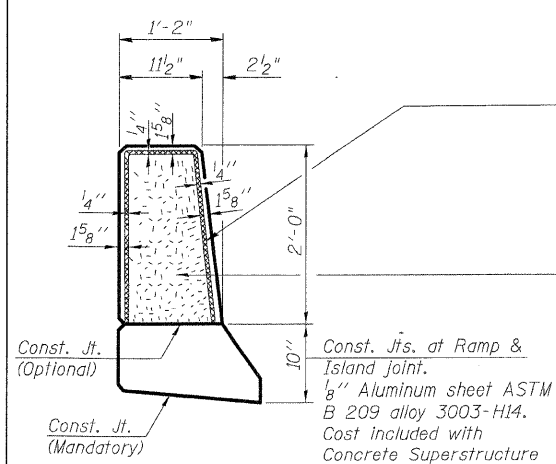

EXPANSION JOINT AT PARAPET DETAIL

Non-staining gray one component non-sag elastomeric gun grade polyurethane sealant meeting the requirements of ASTM C-920, Type S, Grade NS, Class 25, Use T.

1/2" Preformed Self-Expanding Cork Joint Filler according to Article 1051.07 of the Std. Spec. Cost Included with Concrete Superstructure.

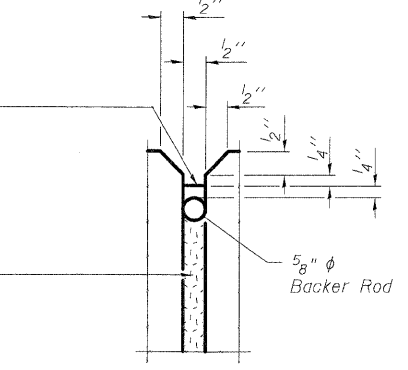

PARAPET CONSTRUCTION JOINT DETAIL

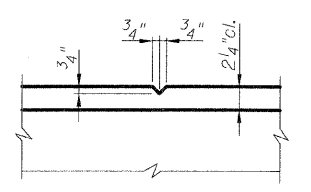

GROOVE JOINT DETAIL

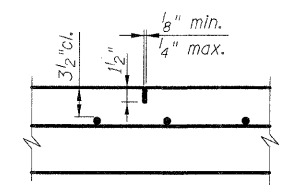

SAWED CONTRACTION JOINT DETAIL

NOTES:

1. Reinforcement bars designated (E) shall be Epoxy Coated.
2. Bars Indicated thus: 3 x 2-#4 etc. indicates 3 lines of bars with 2 lengths per line.
3. Bundle bars according to Ramp A or Ramp D.

REVISIONS	
NAME	DATE

ILLINOIS DEPARTMENT OF TRANSPORTATION
IL ROUTE 162 OVER I-55/70 IN TROY
F.A.I ROUTE 70 SECTION 60-10K-1, 60-10HB
MADISON COUNTY STA. 18+50 TO STA. 17+00
STRUCTURE NO. 060-W004

PARAPET & ANCHORAGE SLAB DETAILS
RAMP A & D

DRAWN BY KM
CHECKED BY BJB
DATE: 05/2006

Sht. R-10 of R-14
STV Incorporated
Engineers/Architects/Planners/Construction Managers
200 W. Monroe Street, Suite 1650
Chicago, IL 60606-3013
312.553-0655, FAX 312.553-0661