

SECTION AT DRAIN

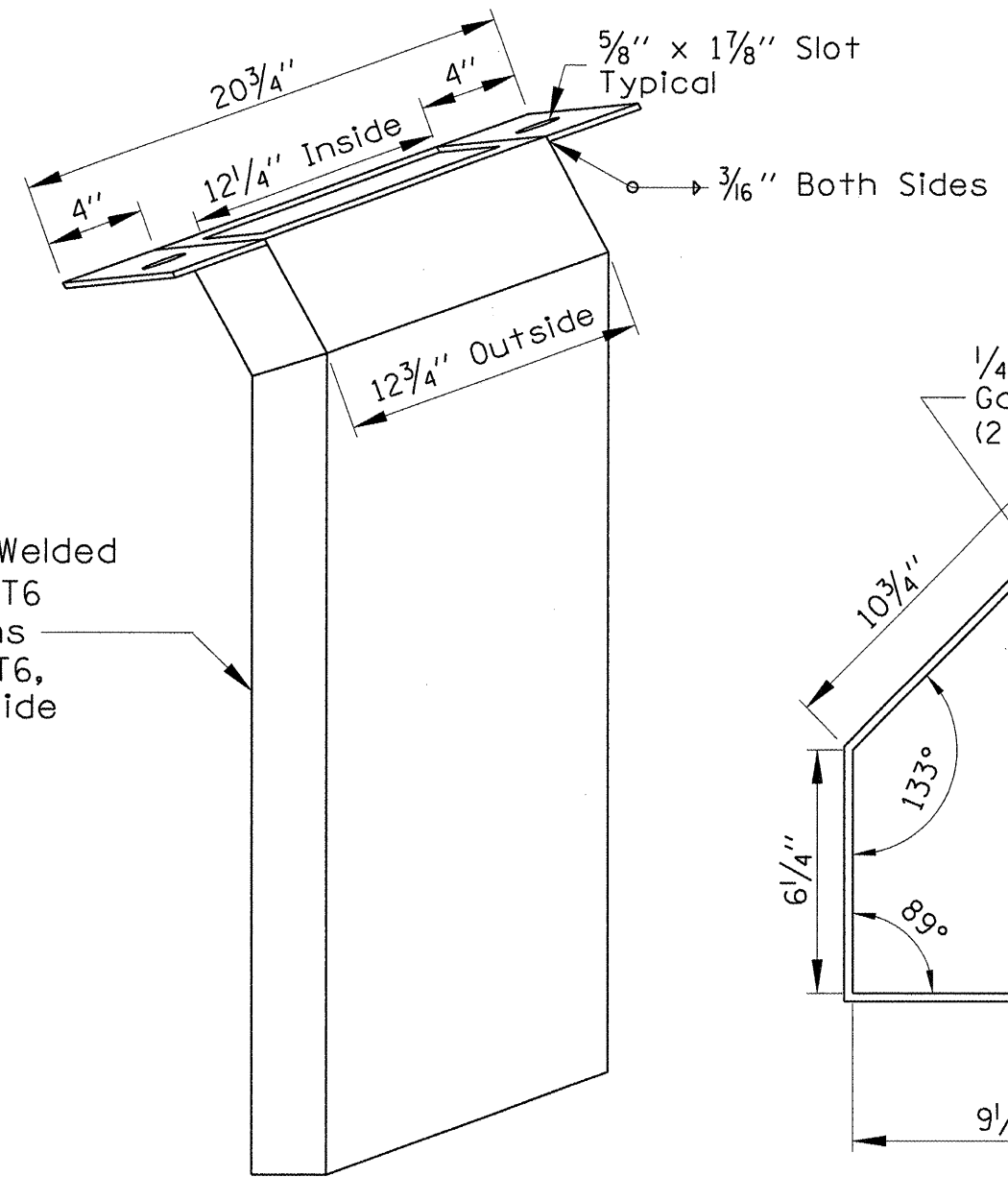

**FLOOR DRAIN
EXTENSION DETAIL**

6 Locations Each Structure

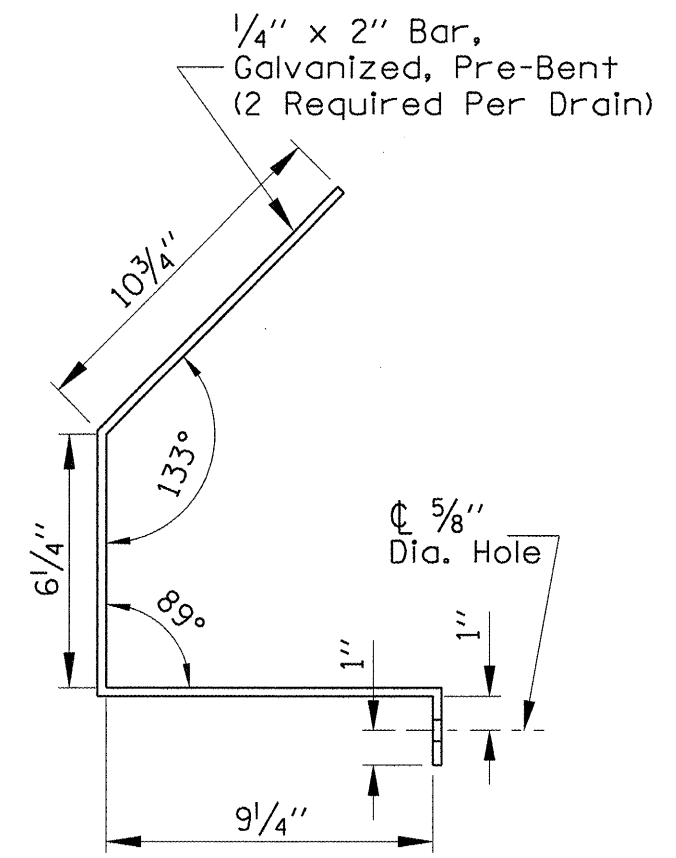

BRACKET DETAIL

FLOOR DRAIN EXTENSION

044-0043
044-0044

| | | | | | | | | | |
|---|---|------------|-----------|---|---------------------------|-----------------------------|----------------|--------------|-----------|
| FILE NAME = | USER NAME = gautneyrk | DESIGNED - | REVISED - | STATE OF ILLINOIS DEPARTMENT OF TRANSPORTATION | F.A.I. RTE. | SECTION | COUNTY | TOTAL SHEETS | SHEET NO. |
| D:\Program Development\Studies and Plan | NDownstairs Design\ZBRIDGE MAINT\CONTRACT | DRAWN | REVISED | | 24 | 09 CM DECK DRAIN EXT FY09-1 | JOHNSON MASSAC | 16 | 8 |
| PLOT SCALE = 5.2953' / IN. | | CHECKED | REVISED | | CONTRACT NO. 78109 | | | | |
| PLOT DATE = 12/22/2008 | | DATE | REVISED | | ILLINOIS FED. AID PROJECT | | | | |
| SCALE: _____ SHEET NO. _____ OF _____ SHEETS STA. _____ TO STA. _____ | | | | | | | | | |