

**STEEL PILE TABLE**

Designation	Depth d	Flange width bf	Web and Flange thickness t	Encasement diameter A
HP 14x117	14 1/4"	14 7/8"	13/16"	30"
x102	14"	14 3/4"	1/6"	30"
x89	13 7/8"	14 3/4"	5/8"	30"
x73	13 5/8"	14 5/8"	1/2"	30"
HP 12x84	12 1/4"	12 1/4"	1/6"	24"
x74	12 1/8"	12 1/4"	5/8"	24"
x63	12"	12 1/8"	1/2"	24"
x53	11 3/4"	12"	7/16"	24"
HP 10x57	10"	10 1/4"	9/16"	24"
x42	9 3/4"	10 1/8"	7/16"	24"
HP 8x36	8"	8 3/8"	7/16"	18"

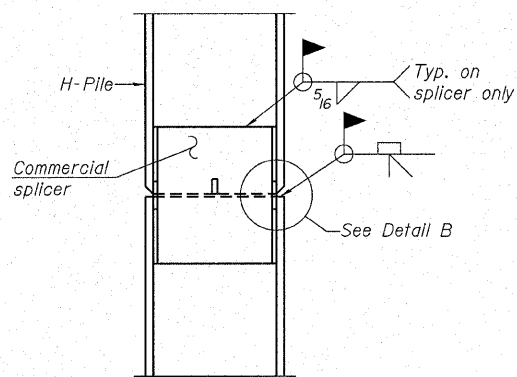

**ELEVATION**

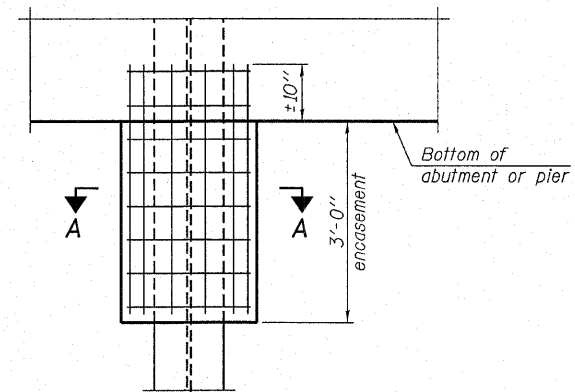

**ELEVATION**

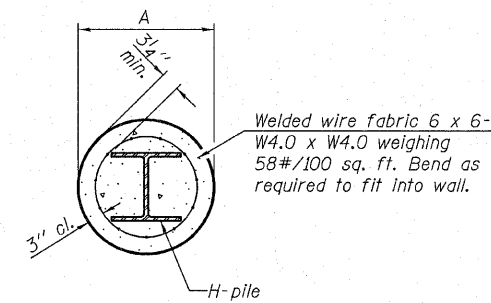

**SECTION A-A**

Note:  
Forms for encasement may be omitted when soil conditions permit.

**PILE ENCASEMENT**

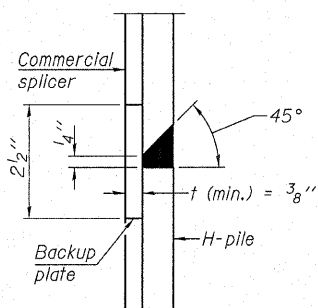

**DETAIL "B"**

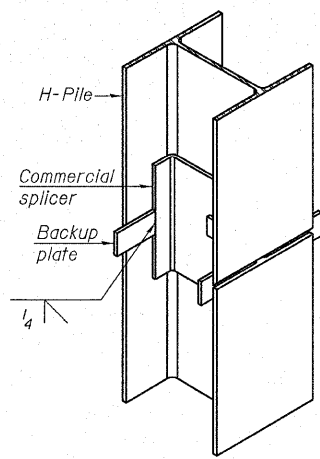

**ISOMETRIC VIEW**

**WELDED COMMERCIAL SPLICE**

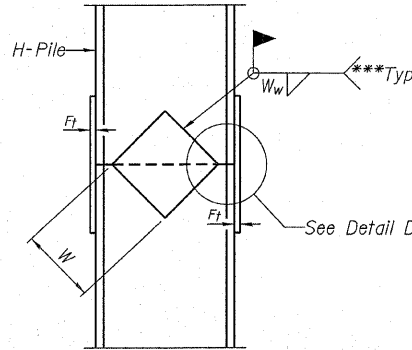

**ELEVATION**

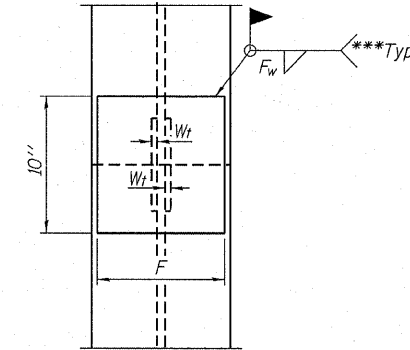

**END VIEW**

Designation	F	F <sub>t</sub>	F <sub>w</sub>	W	W <sub>t</sub>	W <sub>w</sub>
HP 14x117	12 1/2"	1"	7/8"	7 3/4"	5 3/8"	1/2"
x102	12 1/2"	7/8"	3/4"	7 3/4"	5 3/8"	1/2"
x89	12 1/2"	3/4"	1/6"	7 3/4"	5 3/8"	1/2"
x73	12 1/2"	5/8"	9/16"	7 3/4"	5 3/8"	1/2"
HP 12x84	10"	7/8"	1/6"	6 1/2"	5 3/8"	1/2"
x74	10"	7/8"	1/6"	6 1/2"	5 3/8"	1/2"
x63	10"	5/8"	1/2"	6 1/2"	1/2"	3/8"
x53	10"	5/8"	1/2"	6 1/2"	1/2"	3/8"
HP 10x57	8"	3/4"	9/16"	5 1/4"	1/2"	3/8"
x42	8"	5/8"	9/16"	5 1/4"	1/2"	3/8"
HP 8x36	7"	5/8"	7/16"	4 1/4"	1/2"	3/8"

**WELDED PLATE FIELD SPLICE**

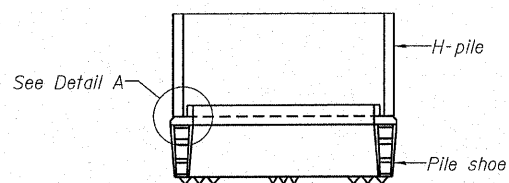

**ELEVATION**

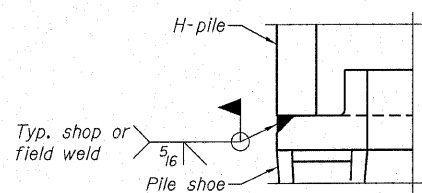

**DETAIL A**

**H-PILE SHOE ATTACHMENT**

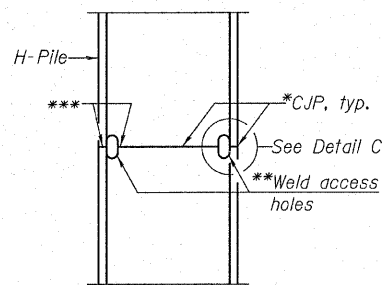

**ELEVATION**

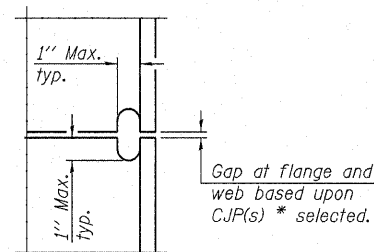

**DETAIL C**

**COMPLETE PENETRATION WELD SPLICE**

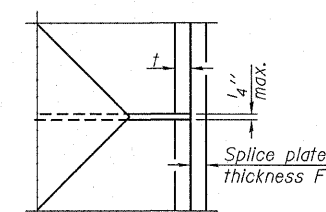

**DETAIL D**

Note:  
The steel H-piles shall be according to AASHTO M270 Grade 50.

- \* Use joint conforming to Figure 3.4 in AWS D1.1, Structure Welding Code - Steel.
- \*\* Preparation per Fig. 5.2 in AWS D1.1, Structure Welding Code - Steel.
- \*\*\* Interrupt welds 1/4" from end of each pile.

**HP PILE DETAILS  
STRUCTURE NO. 041-3742**

DESIGNED - A.S.L.
CHECKED - S.W.M.
DRAWN - D.T.M.
CHECKED - D.A.B.

F-HP

10-1-08

**HAMPTON, LENZINI & RENWICK, INC.**  
CIVIL & STRUCTURAL ENGINEERS  
LAND SURVEYORS

**HLR** 3085 STEVENSON DRIVE, SUITE 201  
SPRINGFIELD, ILLINOIS 62703  
(217) 546-3400

PROJECT NUMBER: 08.0127.130 DATE: 01/21/09

T.R.	SECTION	COUNTY	TOTAL SHEETS	SHEET NO.
10	03-03113-00-BR	JEFFERSON	15	14
CASNER ROAD DISTRICT		CONTRACT NO. 99362		
FED. ROAD DIST. NO.		ILLINOIS FED. AID PROJECT		