

NOTE : FURNISHING AND MOUNTING THE VAN ACCESSIBLE SIGN ON ONE OF THE POSTS SHALL BE CONSIDERED INCIDENTAL TO AR910230 HANDICAP SIGN.

HANDICAP ACCESSIBLE PARKING SIGN DETAIL
NOT TO SCALE

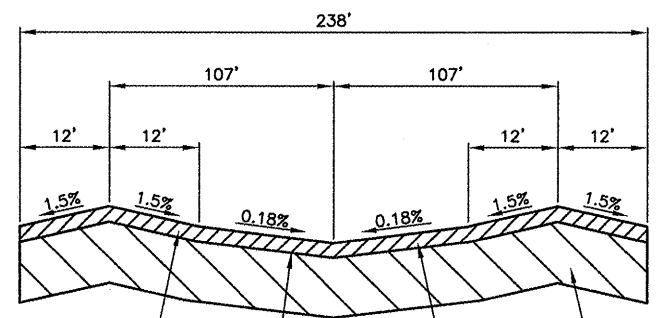

PROPOSED BITUMINOUS TACK COAT (ITEM 603) APPLIED TO MILLED PAVEMENT SURFACE (0.10 GAL./S.Y. DILUTED-SEE SPECIAL PROVISIONS)
 PROPOSED BITUMINOUS SURFACE COURSE (ITEM 401) 2" MINIMUM THICKNESS - SINGLE LIFT
 EXISTING PAVEMENT 5"± BITUMINOUS SURFACE OVER 5" BITUMINOUS BASE
 REMOVE 2" NOMINAL DEPTH OF BITUMINOUS SURFACE (BITUMINOUS PAVEMENT MILLING)

TYPICAL SECTION A-A
PARKING LOT PAVEMENT

- LEGEND**
- ⊗ EXISTING AREA LIGHT POLES
 - EXISTING INLET
 - EXISTING MANHOLE
 - EXISTING FENCE
 - PROPOSED HANDICAP ACCESSIBLE PARKING SIGN

NOTE : OPEN PAVING JOINTS AND/OR CRACKS EXISTING IN THE PAVEMENT AFTER THE BITUMINOUS PAVEMENT MILLING OPERATION SHALL BE DESIGNATED BY THE RESIDENT ENGINEER IN THE FIELD TO BE REPAIRED PRIOR TO PLACING THE BITUMINOUS SURFACE COURSE. THIS WORK SHALL BE PERFORMED ON CRACKS OVER 3/8" IN WIDTH IN ACCORDANCE WITH THE SPECIAL PROVISION FOR BITUMINOUS CRACK REPAIR.

JACKSONVILLE MUNICIPAL AIRPORT JACKSONVILLE, ILLINOIS	
PARKING LOT PLAN LAYOUT AND PAVEMENT MARKING	
HUTCHISON ENGINEERING, INC. JACKSONVILLE, ILLINOIS	
DRAWN BY: T.J.D. DATE : MARCH, 2009	ILL. PROJ. NO. IJX-3866 AIP PROJ. NO. 3-17-0054-B13