

- BASKET ASSEMBLY NOTES:**
- 1.) #9 GA. WIRE SPACER BAR ARC WELDED TO THE BOTTOM OF TOP SPACER BAR. (MAY BE MECHANICALLY ATTACHED IN LIEU OF WELDING) 3 REQUIRED PER UNIT. THIS WIRE MUST BE CUT OR REMOVED PRIOR TO PAVING.
 - 2.) DOWELS SHALL BE EPOXY COATED IN ACCORDANCE TO THE REQUIREMENTS OF AASHTO M254. IMMEDIATELY PRIOR TO PAVING, THE FREE END OF EACH DOWEL SHALL BE GREASED OR OILED, FOR HALF THE LENGTH OF THE DOWEL.
 - 3.) ADJUST HEIGHT OF THE BASKET ASSEMBLIES (IN THE FIELD AT THE TIME OF CONSTRUCTION) SO THAT THE DOWELS ARE IN THE MIDDLE OF THE PROPOSED CONCRETE SLAB.

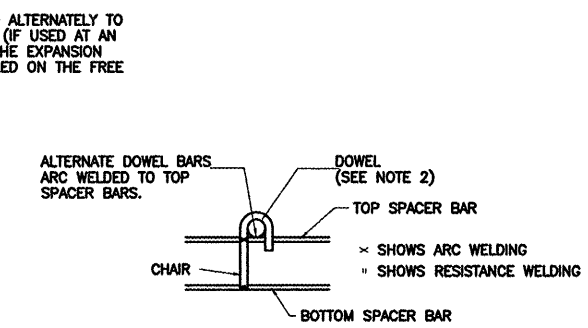

DOWEL BASKET ASSEMBLY DETAILS AND NOTES

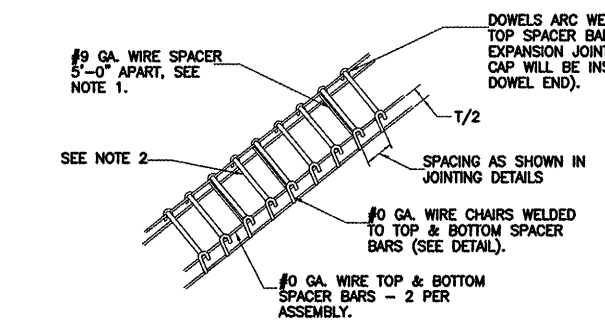
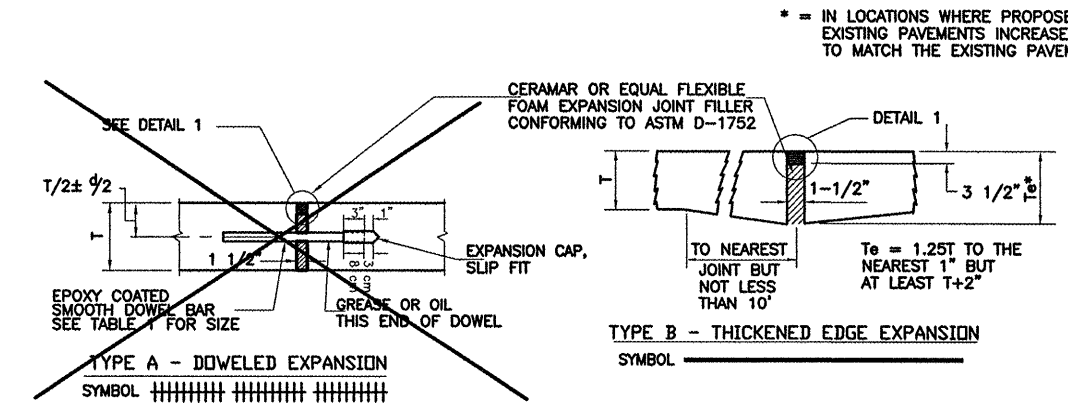

TYPE A - DOWELED EXPANSION
SYMBOL [Symbol]

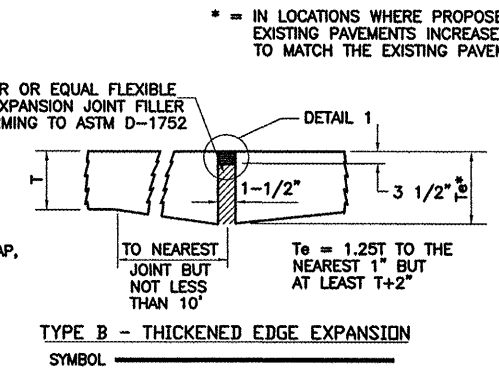

TYPE B - THICKENED EDGE EXPANSION
SYMBOL [Symbol]

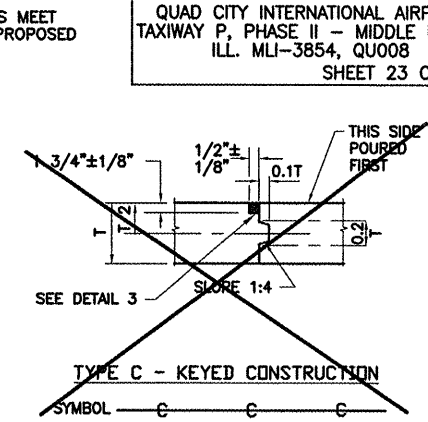

TYPE C - KEYED CONSTRUCTION
SYMBOL [Symbol]

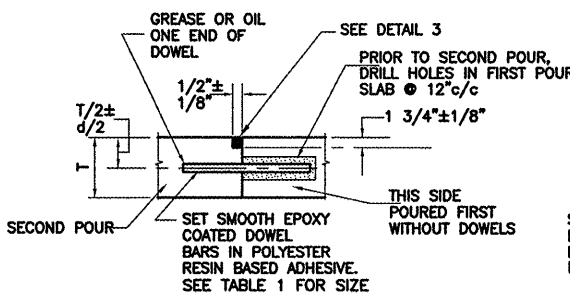

TYPE D - DOWELED CONSTRUCTION
SYMBOL [Symbol]

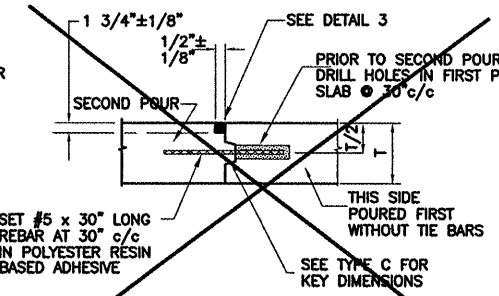

TYPE E - HINGED WITH KEY
SYMBOL [Symbol]

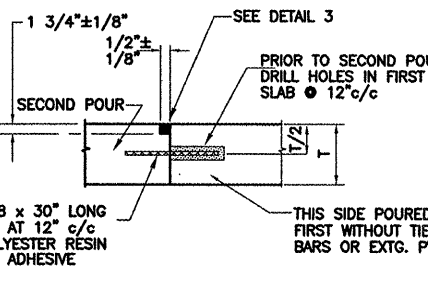

TYPE E-1 - HINGED WITHOUT KEY
SYMBOL [Symbol]

TYPE E-1 JOINT NOTE: THE TYPE E-1 JOINT SHALL BE A CONSTRUCTION BUTT JOINT WITH TIE BARS. THE TIE BARS WILL BE USED TO TRANSFER THE LOAD ACROSS THE JOINT.

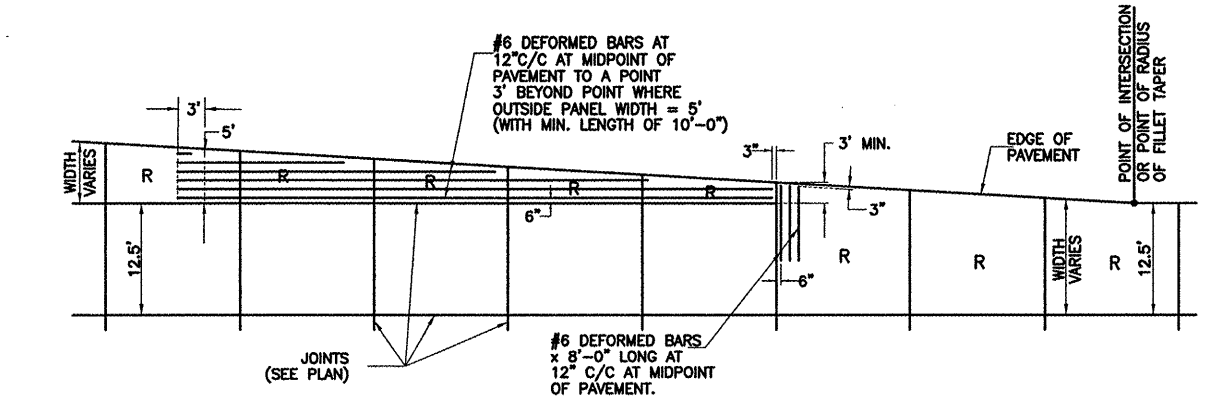

FILLET TAPER DETAIL

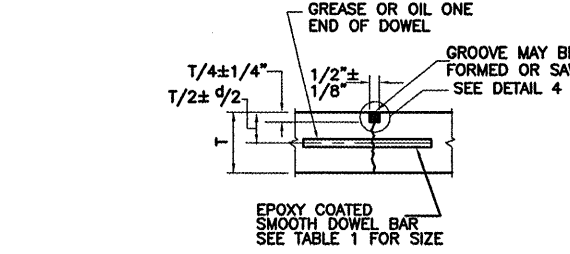

TYPE F - DOWELED CONTRACTION
SYMBOL [Symbol]

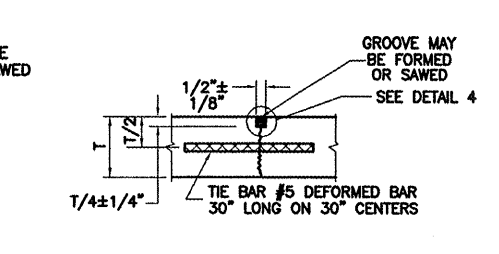

TYPE G - HINGED CONTRACTION
SYMBOL [Symbol]

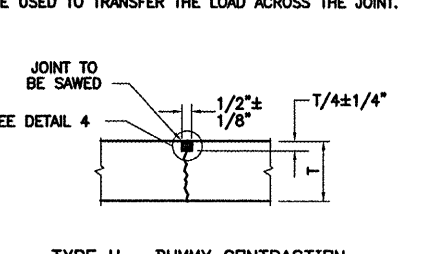

TYPE H - DUMMY CONTRACTION
SYMBOL [Symbol]

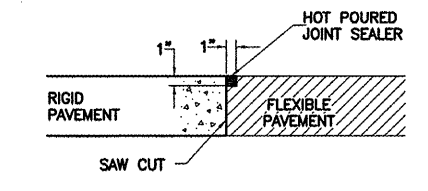

DETAIL - JOINT BETWEEN FLEXIBLE AND RIGID PAVEMENTS

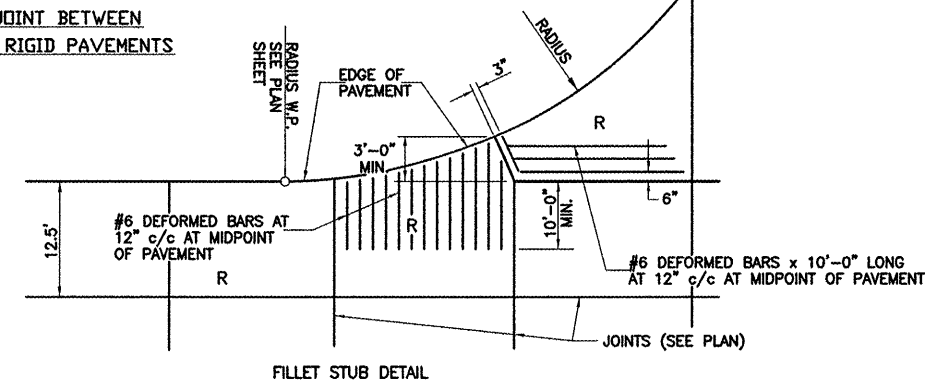

FILLET STUB DETAIL

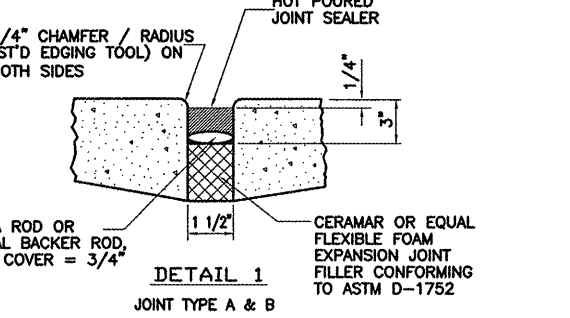

DETAIL 1
JOINT TYPE A & B

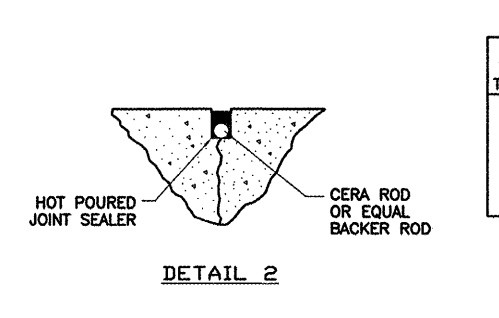

DETAIL 2

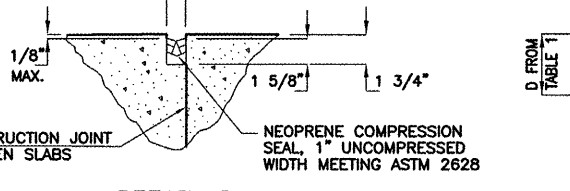

DETAIL 3
JOINT TYPES C, D, AND E

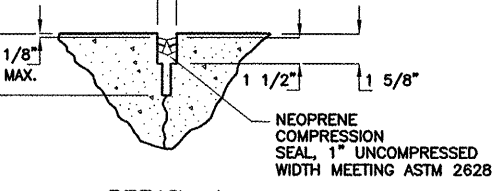

DETAIL 4
JOINT TYPES F, G, AND H

TABLE 1

PAVEMENT THICKNESS T - INCHES	DEPTH OF CONTRACTION JOINT INITIAL SAW CUT D, INCHES D=(T/4)±1/4"	STEEL DOWELS		
		DIAMETER (INCHES)	LENGTH (INCHES)	SPACING (INCHES)
8	2.00	1.00	19	12
9	2.25	1.00	19	12
10	2.50	1.00	19	12
12	3.00	1.00	19	12
15	3.75	1.25	20	15
17	4.25	1.50	20	18

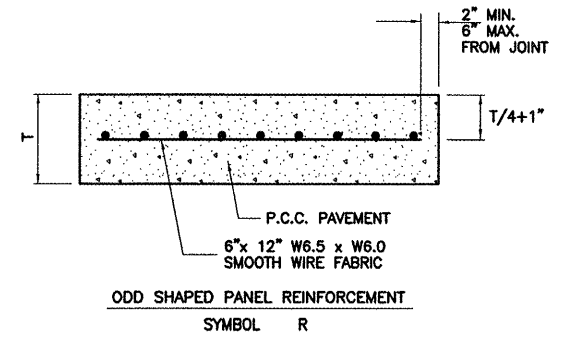

ODD SHAPED PANEL REINFORCEMENT
SYMBOL R