













F.A.P. RTE.	SECTION	COUNTY	TOTAL SHEETS	SHEET NO.
374	326BF-R-1	COOK	279	167
STA.		TO STA.		
FED. ROAD DIST. NO.	ILLINOIS	FED. AID PROJECT		
CONTRACT NO. 62387				



TEMPORARY CABLE PLAN LEGEND

-  TEMPORARY TRAFFIC SIGNAL SECTION OR PEDESTRIAN SIGNAL SECTION 12" (300mm)
-  12" (300mm) PEDESTRIAN SIGNAL SECTION
-  TEMPORARY CONTROLLER CABINET
-  TEMPORARY UNINTERRUPTIBLE POWER SUPPLY
-  TEMPORARY SERVICE INSTALLATION
-  EMERGENCY VEHICLE LIGHT DETECTOR
-  CONFIRMATION BEACON
-  PUSH-BUTTON DETECTOR
-  VIDEO VEHICLE DETECTOR
-  DENOTES NUMBER OF CONDUCTORS ALL CABLE NO. 14 EXCEPT AS INDICATED ALL LOOP DETECTOR CABLE TO BE SHIELDED
-  FIBER OPTIC CABLE NO. 62.5/125 MM12F SMI2F
-  VIDEO DETECTOR CABLE PER VIDEO SYSTEM MANUFACTURER'S RECOMMENDATION
-  GROUND ROD

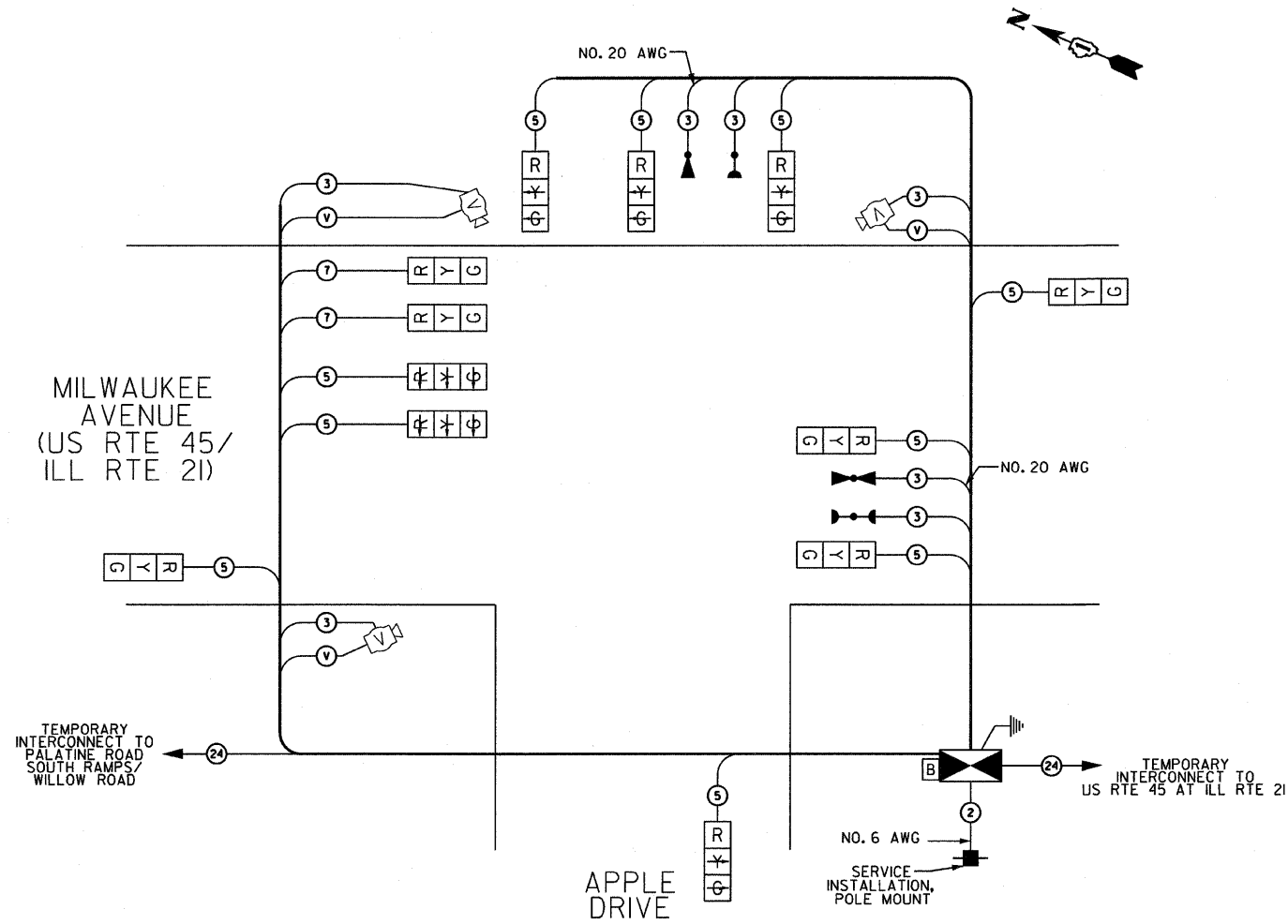

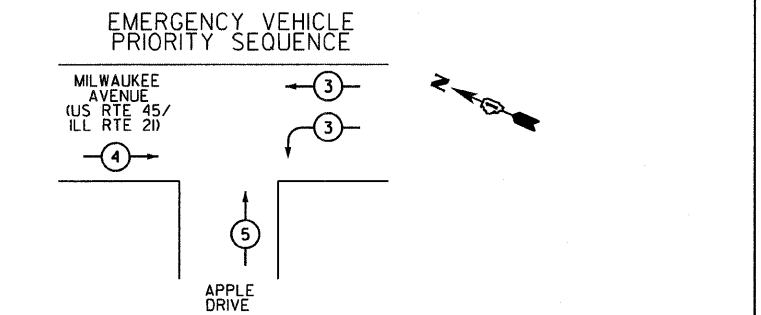
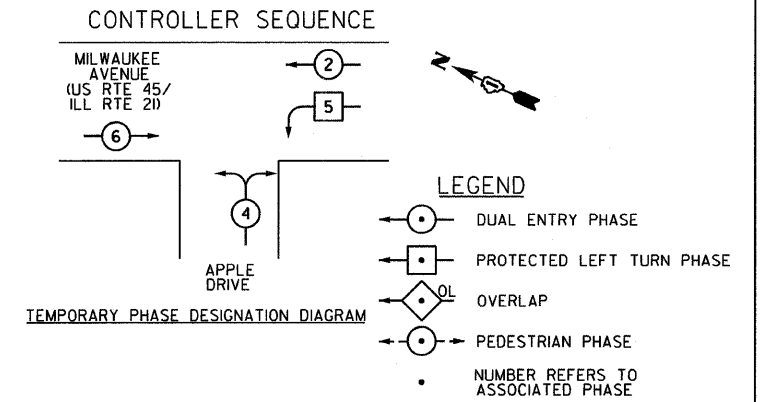
TEMPORARY CABLE PLAN



EMERGENCY VEHICLE PREEMPTORS			
EMERGENCY VEHICLE PREEMPTOR	3	4	5
MOVEMENT			

I.D.O.T. TRAFFIC SIGNAL INSTALLATION ELECTRICAL SERVICE REQUIREMENTS					TOTAL WATTAGE
TYPE	NO. OF LAMPS	INCAND.	LED	% OPERATION	
SIGNAL (RED)	12	135	17	0.50	102
(YELLOW)	10	135	25	0.25	62.5
(GREEN)	10	135	15	0.25	37.5
ARROW	4	135	12	0.10	4.8
PED. SIGNAL		90	25	1.00	
CONTROLLER	1	100	100	1.00	100
ILLUM. SIGN		252		0.05	
FLASHER				0.50	
ENERGY COSTS TO:				TOTAL =	306.8

FOUNDATION (DEPTH)	FT. (m)	CABLE SLACK	FT. (m)	VERTICAL	FT. (m)
TYPE A - POST	4 (1.2)	HANDHOLE	6.5 (2.0)	ALL FOUNDATIONS	3.5 (1.0)
D - CONTROLLER	4 (1.2)	DOUBLE HANDHOLE	13 (4.0)	MAST ARM (L) POLE	20'+L-2' (6m+L-0.6m)=
E - M. ARM POLE		SIGNAL POST	2 (0.6)		
24" (600 mm)	10 (3.0)	CONTROLLER CAB.	1 (0.5)	BRACKET MOUNTED	13 (4.0)
30" (750 mm)	15 (4.6)	FIBER OPTIC	13 (4.0)	PED PUSHBUTTON	4 (1.2)
		ELECTRIC SERVICE	1 (0.5)	ELECTRIC SERVICE	13.5 (4.1)
		GROUND CABLE	1 (0.5)	SERVICE TO GROUND	13.5 (4.1)
				POST MOUNTED	6 (1.8)

NOTE: THE TEMPORARY TRAFFIC SIGNAL CONTROL EQUIPMENT FOR THIS INTERSECTION SHALL BE 'ECONOLITE' BRAND TO MATCH THE EXISTING SYSTEM.

SPAAN Tech, Inc.

311 S. Wacker Drive, Suite 2400
Chicago, Illinois 60606

phone: 312.277.8800
fax: 312.277.8808
web: www.SpaanTech.com

TS-7 OF 39

ILLINOIS DEPARTMENT OF TRANSPORTATION

TEMPORARY CABLE PLAN AND TEMPORARY PHASE DESIGNATION DIAGRAM MILWAUKEE AVENUE (US RTE 45/ILL RTE 21) AT APPLE DRIVE PRE-STAGE I

SCALE: NONE
DATE: 02/05/08

DRAWN BY: RAS
DESIGN BY: RAS
CHECKED BY: ADD

default
 untitle
 07167.000 - ILL Rte 21 - IDOT Dist 1
 07167.000 - ILL Rte 21 - IDOT Dist 1
 I:\Working Files\Drawing Files\Sh\Final\TS\TS-7.dgn
 20.0000 11 / IN.
 9:52:53 AM
 1/30/2008

CITY OF PROSPECT HEIGHTS
8 NORTH ELMHURST ROAD
PROSPECT HEIGHTS, ILLINOIS 60070

ENERGY SUPPLY CONTACT: MS. JUDY SCHOMER
PHONE: (847) 870-2056
COMPANY: COMED