

* REDUCE TO 40 FEET (12.2 METERS) ON CENTER ON CURVES WHERE ADVISORY SPEEDS ARE 10 MPH (15 km/h) LOWER THAN POSTED SPEEDS.

** DOUBLE LANE LINE MARKERS SHALL BE SPECIFIED AND SPACED AS SHOWN IN HIGHWAY STANDARD 781001 FOR MULTI-LANE DIVIDED AND UNDIVIDED HIGHWAYS.

GENERAL NOTES:

- ⓑ TURN ARROW PAIRS SHALL BE PLACED AT 250' (75 m) INTERVALS AND SHALL BE EVENLY SPACED BETWEEN BOTH ENDS OF THE BIDIRECTIONAL LEFT TURN LANE.
- ⓒ THE SOLID YELLOW PAVEMENT MARKINGS [2] SHOULD GENERALLY START OR END NEAR THE RADIUS POINT OF EACH STREET RETURN EXCEPT WHERE ONE OR BOTH ENDS WOULD INCLUDE STOP BARS.
- ⓓ THE SKIP-DASH PAVEMENT MARKINGS [1] OR [7] SHOULD BE CENTERED BETWEEN BOTH ENDS OF EACH CITY BLOCK AND SHALL BE PLACED SO THEY LINE UP ACROSS FROM EACH OTHER. SEE EXAMPLE ON SHEET 2 OF 3.
- ⓔ USE LARGE ARROW SIZE FOR BOTH RURAL AND URBAN LOCATIONS. (SEE LAST PAGE OF SECTION 780x FOR SYMBOLS TABLE)

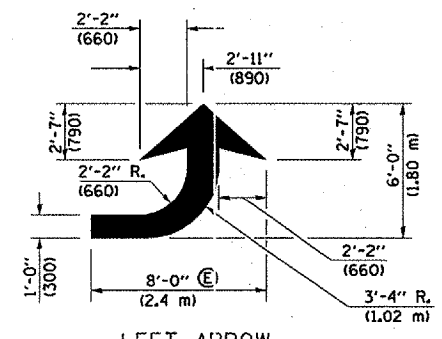

LEFT ARROW
REVERSE FOR RIGHT ARROW
AREA = 15.6 SQ. FT. (1.47 m²)
(WHITE)

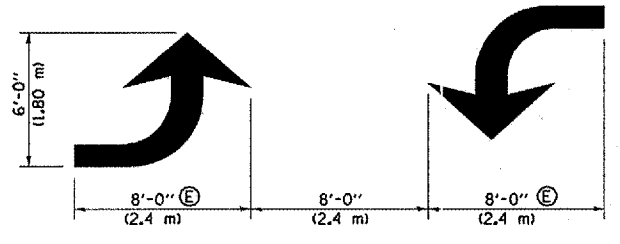

TYPICAL DOUBLE TURN ARROWS (WHITE)

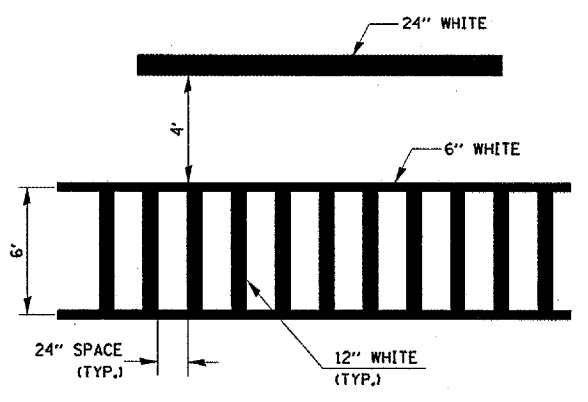

TYPICAL SPACING FOR CROSSWALKS & STOP BARS

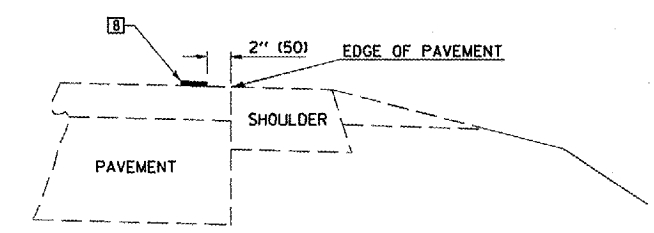

RELATIONSHIP OF EDGE LINE TO EDGE OF PAVEMENT
(SAFETY SHOULDER OR PAVED SURFACE)
SEE ARTICLE 780.04

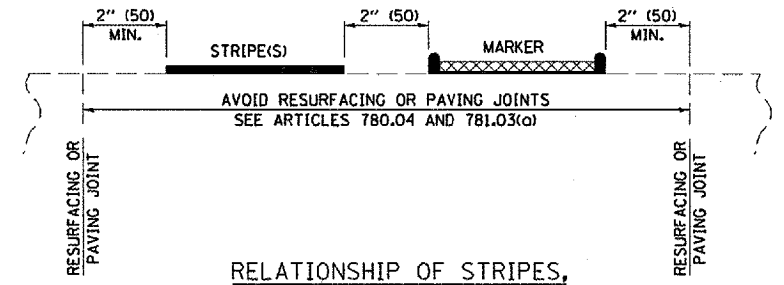

RELATIONSHIP OF STRIPES, MARKERS AND JOINTS

CROSSWALK WIDTH 6'-0" (1.8 m) OR AS SHOWN IN THE PLANS

4' (1.2 m) MIN., 30' (9.1 m) MAX.
IF CROSSWALK IS NOT PRESENT, LOCATE STOP LINE @ DESIRED STOPPING POINT

Note: All dimensions are in INCHES (millimeters) unless otherwise shown.

FILE NAME: c:\proj\cjs\state\d578699\780699plens.dgn	USER NAME: aallierbw	DESIGNED: -	REVISED: 11/06	STATE OF ILLINOIS DEPARTMENT OF TRANSPORTATION	PAVEMENT MARKING AND MARKERS (RURAL & URBAN APPLICATIONS)		F.A.S. RTE. 1517	SECTION 05 BEAM REPLACE 2008-2	COUNTY PIATT	TOTAL SHEETS 18	SHEET NO. 16	
	PLOT SCALE: 100,0000 / IN.	DRAWN: -	REVISED: -		SCALE: NA	SHEET NO. 2 OF 4 SHEETS	STA. TO STA.	FED. ROAD DIST. NO.	ILLINOIS FED. AID PROJECT	CONTRACT NO. 70699		
	PLOT DATE: 2/6/2008	CHECKED: -	REVISED: -									
		DATE: -	REVISED: -									

DISTRICT 5 DETAIL NO. 7800AAAA