

RUMBLE STRIPS	
STATION RANGE	QUANTITY (FOOT)
215+36.33 TO 221+46.97 (RADIUS RETURN), LEFT	610.6
221+69.30 (RADIUS RETURN) TO 299+00.00, LEFT	7730.7
317+00.00 TO 358+43.96, LEFT	4144.0
215+36.33 TO 299+00.00, RIGHT	8363.7
317+00.00 TO 335+49.14, RIGHT	1849.1
337+15.61 TO 358+43.96, RIGHT	2128.4
TOTAL = 24,826.5 FEET	

HOT MIX ASPHALT SHOULDERS, 8"			
STATION RANGE	SHOULDER LENGTH (FT)	SHOULDER WIDTH (FT)	QUANTITY (SQ YD)
215+36.33 TO 221+46.97 (RADIUS RETURN), LEFT	610.6	3.0	203.5
221+69.30 (RADIUS RETURN) TO 299+00.00, LEFT	7730.7	3.0	2576.9
299+00.00 TO 303+40.59 (RADIUS RETURN), LEFT	457.0	3.0	152.3
303+70.06 (RADIUS RETURN) TO 317+00.00, LEFT	1355.0	3.0	451.7
317+00.00 TO 347+87.91, LEFT	3087.9	3.0	1029.3
215+36.33 TO 299+00.00, RIGHT	8363.7	3.0	2787.9
299+00.00 TO 302+49.40, RIGHT	349.4	3.0	116.5
304+32.95 TO 317+00.00, RIGHT	1267.1	3.0	422.4
317+00.00 TO 335+49.14, RIGHT	1849.1	3.0	616.4
337+15.61 TO 347+87.91, RIGHT	1072.3	3.0	357.4
TOTAL = 8,714.3 SQ YD			

COMBINATION CURB & GUTTER REMOVAL		
STATION RANGE	LENGTH OF RUN	QUANTITY (FT)
334+36.48 TO 336+19.55, LEFT	183.07'	183.1
333+90.11 TO 335+49.14, RIGHT	159.03'	159.0
TOTAL = 342.1 FEET		

GUTTER REMOVAL		
STATION RANGE	LENGTH OF RUN	QUANTITY (FT)
326+91.50 TO 334+36.48, LEFT	744.98'	745.0
TOTAL = 745.0 FEET		

PAINT PAVEMENT MARKING - LINE 5" SCHEDULE		
STATION RANGE	DESCRIPTION	QUANTITY (FOOT)
215+36.33 TO 221+00.00	LEFT EDGE LINE - WHITE	564
222+00.00 TO 303+00.00	LEFT EDGE LINE - WHITE	8100
304+10.00 TO 311+00.00	LEFT EDGE LINE - WHITE	690
311+85.00 TO 347+87.91	LEFT EDGE LINE - WHITE	4659
215+36.33 TO 302+50.00	RIGHT EDGE LINE - WHITE	8714
304+40.00 TO 335+50.00	RIGHT EDGE LINE - WHITE	3110
337+15.00 TO 347+87.91	RIGHT EDGE LINE - WHITE	2129
215+36.33 TO 331+85.00	30' SKIP / 10' DASH CENTERLINE - WHITE	3019
343+60.00 TO 347+87.91		
331+85.00 TO 343+60.00	W.B. NO PASSING LINE - YELLOW	1175
323+70.00 TO 338+50.00	E.B. NO PASSING LINE - YELLOW	1480
TOTAL = 33,640 FOOT		

OBJECT MARKER TYPE 3 (OM-3L & OM-3R) *		
STATION	OFFSET	QUANTITY (EACH)
335+04.8	27', LEFT	1 (OM-3L)
335+94.0	29', LEFT	1 (OM-3L)
334+19.9	34', RIGHT	1 (OM-3R)
335+05.9	27', RIGHT	1 (OM-3R)
TOTAL = 4		

\* - EACH SIGN IS 12" X 36"

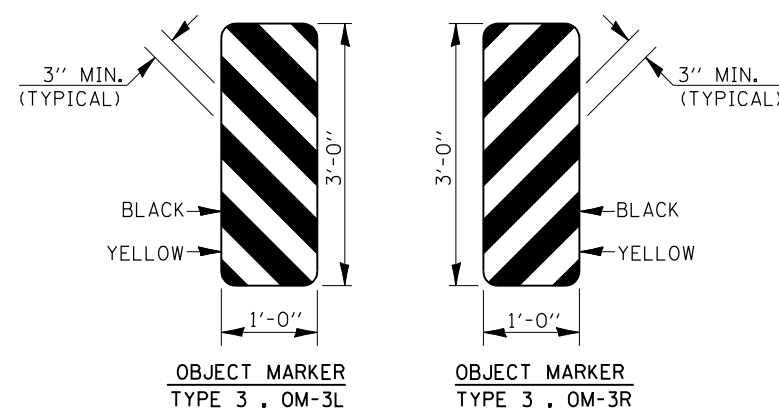

DELINIATORS		
LOCATION	OFFSET (FOOT)	QUANTITY (EACH)
327+00.00, RIGHT	19 RT.	1
328+20.00, RIGHT	19 RT.	1
329+40.00, RIGHT	19 RT.	1
330+60.00, RIGHT	19 RT.	1
331+80.00, RIGHT	19 RT.	1
333+00.00, RIGHT	19 RT.	1
334+20.00, RIGHT	19 RT.	1
335+40.00, RIGHT	19 RT.	1
TOTAL = 8 EACH		

\* - D-6 RUMBLE STRIPS 2008-01

FILE NAME =	USER NAME = laughlin1	DESIGNED - RTS	REVISED - DEC. 27, 2007
ct:\projects\d610607\shsch.dgn		DRAWN - RTS	REVISED - JAN. 07, 2007
		CHECKED - MEB	REVISED -
		DATE - DEC. 27, 2007	REVISED -

STATE OF ILLINOIS  
DEPARTMENT OF TRANSPORTATION

SCHEDULES	
SCALE: NO SCALE	SHEET NO. 2 OF 2 SHEETS
STA.	TO STA.

FAP RTE.	SECTION	COUNTY	TOTAL SHEETS	SHEET NO.
1613	*	SANGAMON	20	7
FED. ROAD DIST. NO.			ILLINOIS FED. AID PROJECT	
			CONTRACT NO. 72B29	