

STATE OF ILLINOIS
DEPARTMENT OF TRANSPORTATION

CONTRACT: 78040
ROUTE: F.A.I. 57
SECTION: (02-1B-1)P-1
COUNTY: ALEXANDER, IL; MISSISSIPPI, MO
SHEET 43 OF 67
FOR INFORMATION ONLY

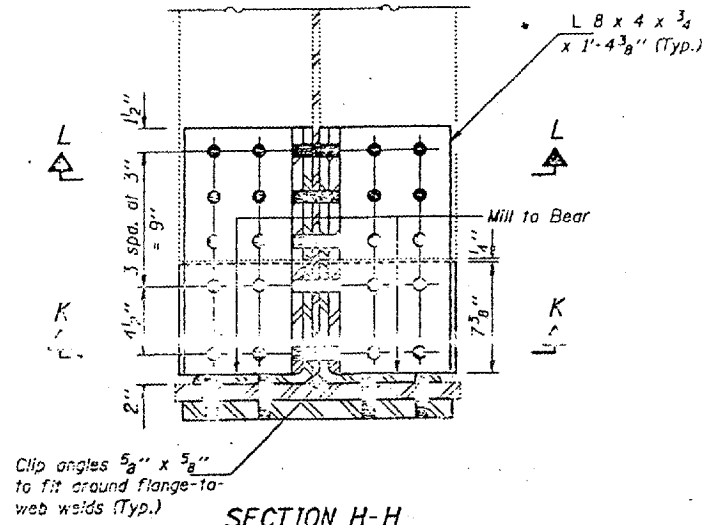

SECTION H-H

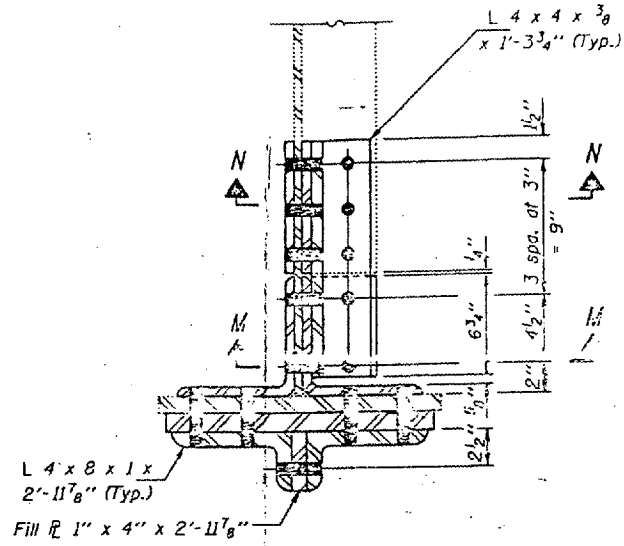

SECTION I-I

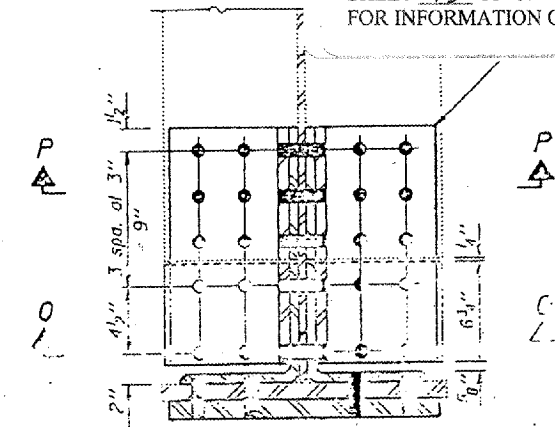

SECTION J-J

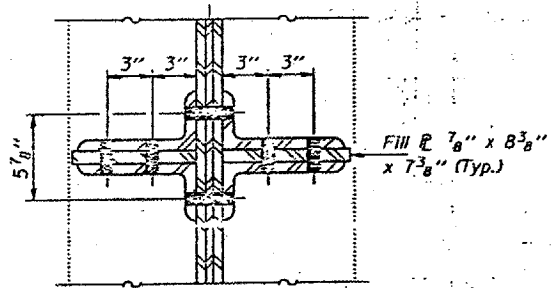

SECTION K-K

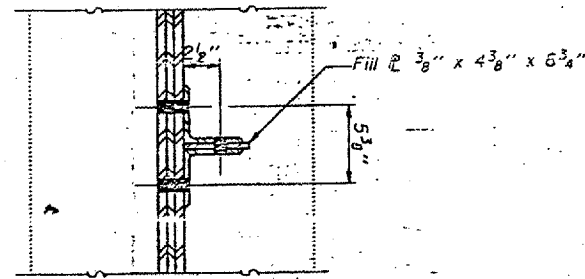

SECTION M-M

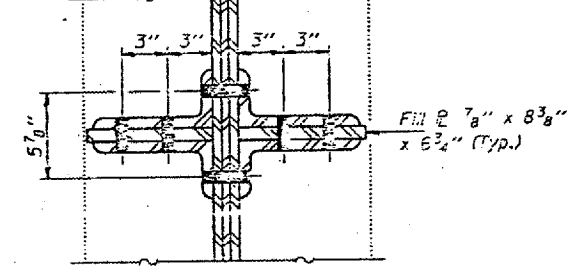

SECTION O-O

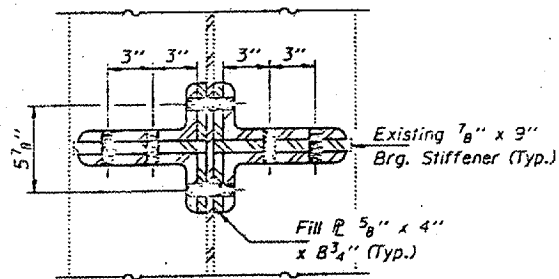

SECTION L-L

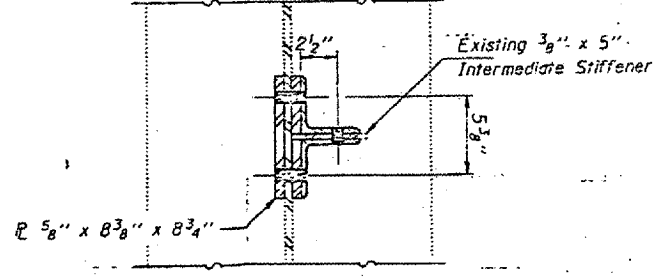

SECTION N-N

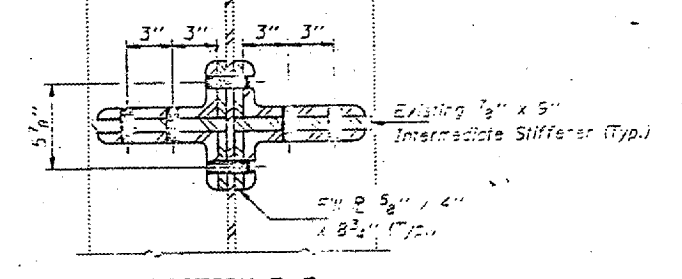

SECTION P-P

DESIGNED *Kenneth P. Little*
CHECKED *CHM*
DRAWN *Paul Summer*
CHECKED *KPS*

March 8 1993
EXAMINED *Josh E. Adams*
PASSED
APPROVED

BRIDGE NO. 1
STRUCTURE NO. 002-0022
FOR INFORMATION ONLY

FLOOR BEAM REPAIRS
F.A.I. RT. 57 SEC. (02-1B-1) (DL-65)
ALEXANDER COUNTY
STA. 1168+50
STR. No. 002-0022