

A - TYPICAL STANDARD BOLLARD DETAIL - THICKENED SLAB

NOT TO SCALE

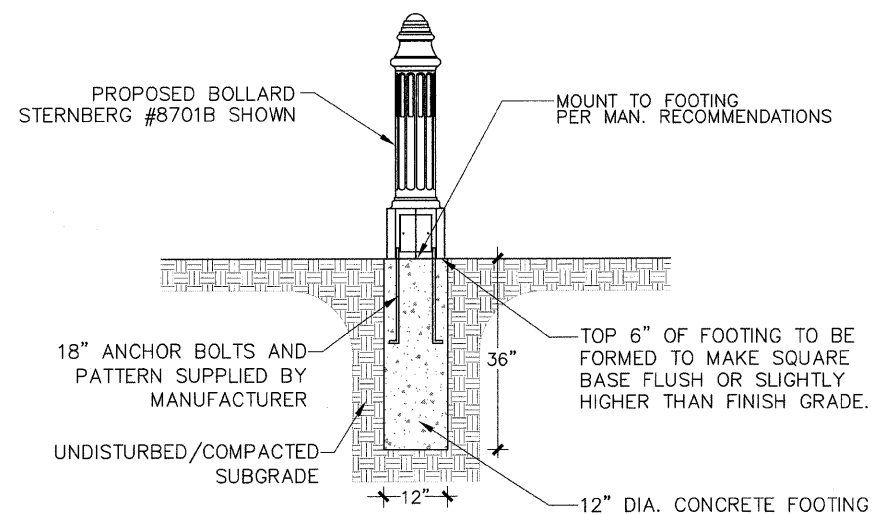

B - TYPICAL STANDARD BOLLARD DETAIL - CONCRETE FOOTING

NOT TO SCALE

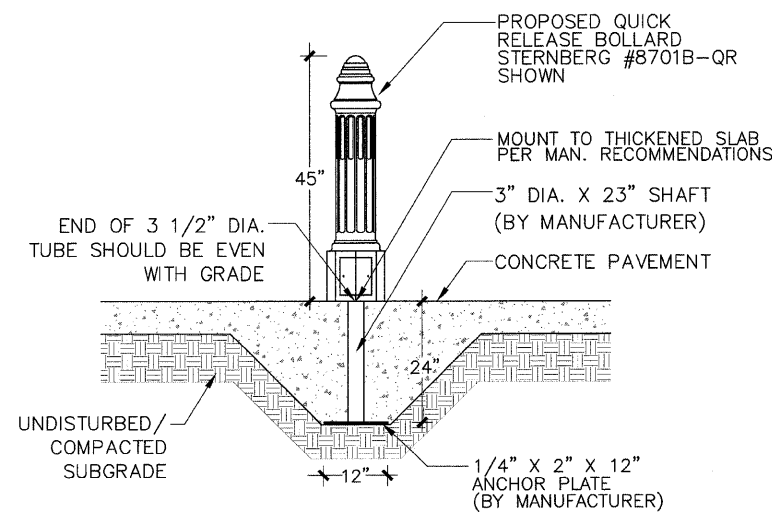

C - TYPICAL QUICK RELEASE BOLLARD DETAIL

NOT TO SCALE

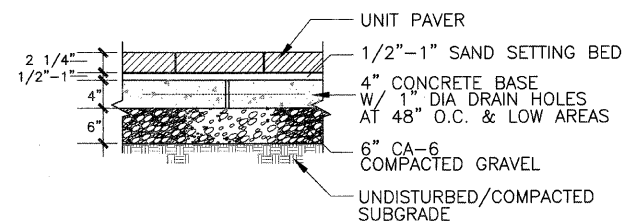

D - TYPICAL UNIT PAVER DETAIL

NOT TO SCALE

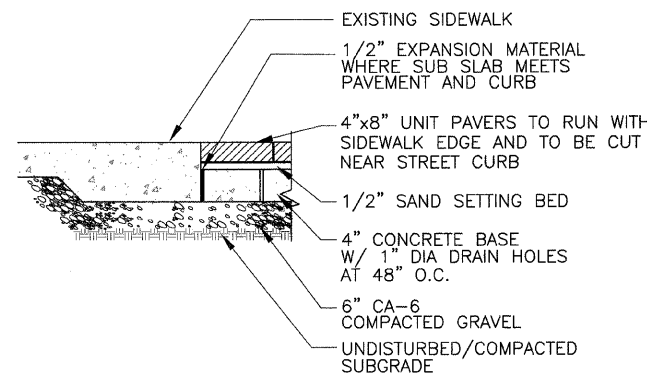

E - TYPICAL UNIT PAVER AT SIDEWALK DETAIL

NOT TO SCALE

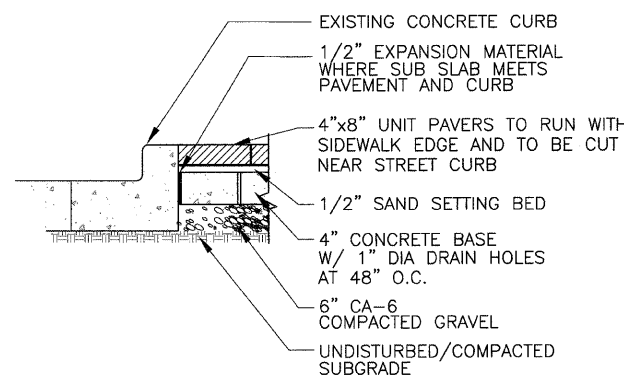

F - TYPICAL UNIT PAVER AT STREET CURB DETAIL

NOT TO SCALE

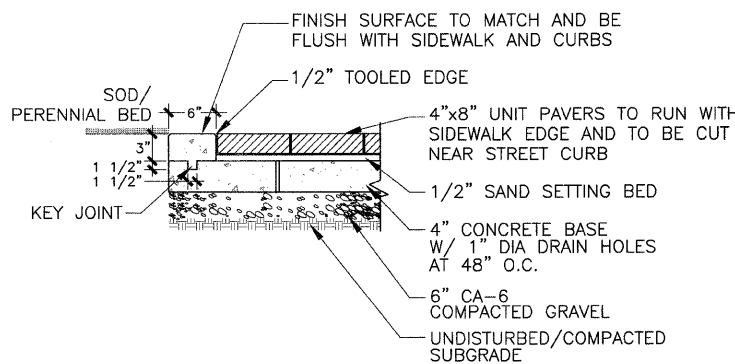

G - TYPICAL UNIT PAVER AT SOD/PERENNIAL BED DETAIL

NOT TO SCALE

Note: See "Ramp Railing Details" Plan Sheet for Fabrication Notes and Details

Bollard Alternates

- Sternberg Lighting - Geneva Unlit Bollard (Shown)
- Spring City Electrical - Radnor Bollard
- Heritage Castings & Ironworks - B621 Series Bollard

- Sternberg Lighting - Geneva Quick Release Unlit Bollard (Shown)
- Spring City Electrical - Radnor Custom Quick Release Bollard
- Heritage Castings & Ironworks - B621 Series Custom Quick Release Bollard

REV. NO.	DESCRIPTION	BY	DATE	APPROVED
BOLLARD AND PAVER DETAILS				
DESIGN KLM DATE 12/07	WEST MAIN STREET PH 2 IMPROVEMENTS CITY OF DECATUR	SCALE		
DRAWN MRG DATE 12/07		PROJECT NO.		
CHECKED KLM DATE 12/07		DATE		
APPROVED DATE		1/11/08		
CLIENT APPR. DATE	Massie Massie & Associates LAND PLANNING AND LANDSCAPE ARCHITECTURE 421 West Main Street, Decatur, IL 62522 217/424-0792 www.Massie-Massie-Associates.com			L-9