

NOTES :
 ① 6" for concrete center curb, type D and 8" for concrete center curb, type C.

LEGEND
 T = Normal pavement depth

INDIANA DEPARTMENT OF TRANSPORTATION
CONCRETE CENTER CURBS
 TYPE C & D
 APRIL 1995
 STANDARD DRAWING NO E 605-CNCC-03
 DETAILS PLACED IN THIS FORMAT 11-25-99
 /s/ Anthony L. Dremowich 11-25-99
 DIRECTOR STANDARD ENGINEER DATE
 /s/ Firooz Zandi 11-25-99
 CHIEF HIGHWAY ENGINEER DATE
 ORIGINALLY APPROVED 4-03-95

GENERAL NOTES

1. The tip of the lane indication arrow shall be 20 ft in advance of the nearest edge of the stop line.

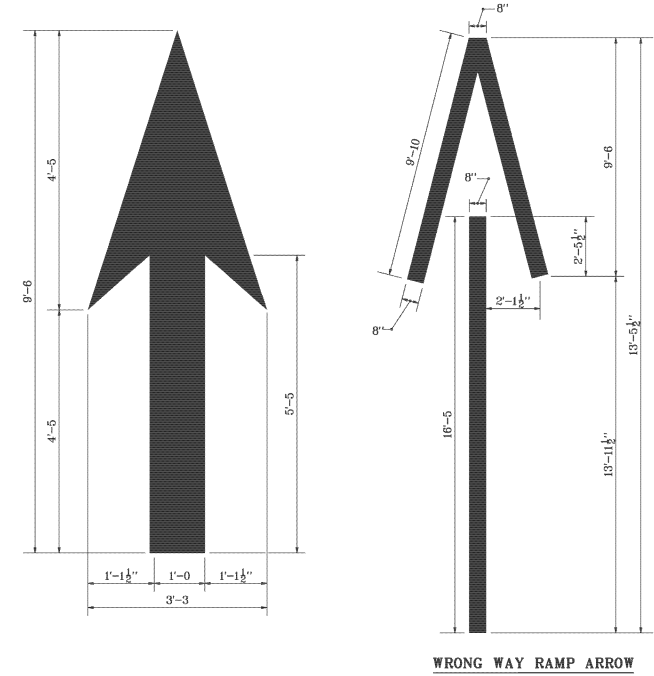

INDIANA DEPARTMENT OF TRANSPORTATION
TRANSVERSE MARKINGS
 MARCH 1995
 STANDARD DRAWING NO E 808-MKPM-01
 DETAILS PLACED IN THIS FORMAT 7-27-99
 /s/ Anthony L. Dremowich 7-27-99
 DIRECTOR STANDARD ENGINEER DATE
 /s/ Firooz Zandi 7-27-99
 CHIEF HIGHWAY ENGINEER DATE
 ORIGINALLY APPROVED 3-0-95

GENERAL NOTES

1. The tip of the lane indication arrow closest to the stop line shall be 20 ft in advance of the nearest edge of the stop line.

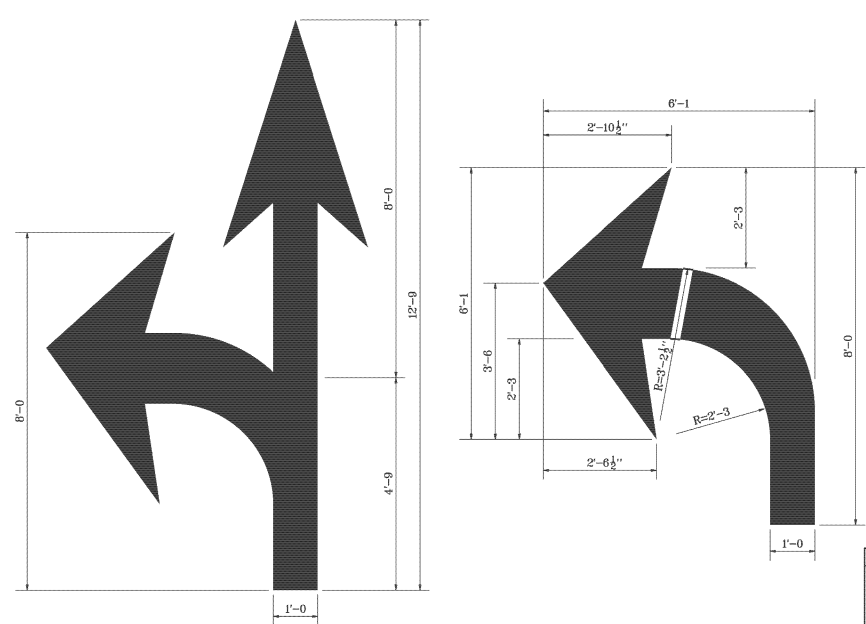

INDIANA DEPARTMENT OF TRANSPORTATION
TRANSVERSE MARKINGS
 MARCH 1995
 STANDARD DRAWING NO E 808-MKPM-02
 DETAILS PLACED IN THIS FORMAT 7-27-99
 /s/ Anthony L. Dremowich 7-27-99
 DIRECTOR STANDARD ENGINEER DATE
 /s/ Firooz Zandi 7-27-99
 CHIEF HIGHWAY ENGINEER DATE
 ORIGINALLY APPROVED 3-0-95

GENERAL NOTES

1. The top edge of the word ONLY shall be located in advance of the back edge of the lane indication arrow, at least 4 times the height of the characters for posted speeds < 45 mph but not more than 10 times the height of the characters for posted speeds > 45 mph.

2. Horizontal strokes are 1'-4 wide. Vertical strokes are 4" wide.

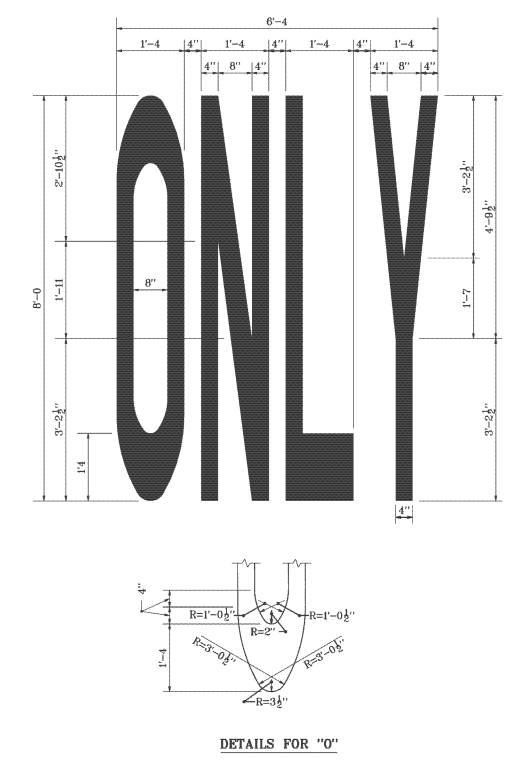

INDIANA DEPARTMENT OF TRANSPORTATION
TRANSVERSE MARKINGS
 JANUARY 2000
 STANDARD DRAWING NO E 808-MKPM-03
 DETAILS PLACED IN THIS FORMAT 7-27-99
 /s/ Anthony L. Dremowich 7-27-99
 DIRECTOR STANDARD ENGINEER DATE
 /s/ Firooz Zandi 7-27-99
 CHIEF HIGHWAY ENGINEER DATE
 ORIGINALLY APPROVED 3-0-95

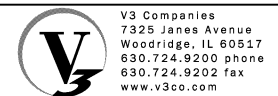

USER NAME = hshah
 DESIGNED - DSS
 DRAWN - DRP
 CHECKED - VJD
 DATE - 08/14/2013

DESIGNED - DSS
 DRAWN - DRP
 CHECKED - VJD
 DATE - 08/14/2013

REVISED -
 REVISED -
 REVISED -
 REVISED -

STATE OF ILLINOIS
 DEPARTMENT OF TRANSPORTATION

INDIANA DEPARTMENT OF TRANSPORTATION
 ROADWAY STANDARD DETAILS

SCALE: N/A SHEET NO. 1 OF 2 SHEETS

F.A.P. RTE.	SECTION	COUNTY	TOTAL SHEETS	SHEET NO.
353	11-Y-A	COOK	354	306
CONTRACT NO. 60R19				

ILLINOIS FED. AID PROJECT