

EXISTING TYPICAL SECTION

STA. 71+00 TO STA. 100+16

LEGEND

- ① EXISTING P.C.C. PAVEMENT, 9"±
- ② EXISTING HMA PAVEMENT AFTER MILLING, 3"±
- ③ EXISTING COMBINATION CONCRETE CURB & GUTTER
- ④ PROPOSED HMA SURFACE REMOVAL, 2 1/2"
- ⑤ PROPOSED HMA SURFACE REMOVAL (OVER GUTTER), 1"
- ⑥ PROPOSED POLYMERIZED LEVELING BINDER (MM), IL.-4.75, N50, 3/4"
- ⑦ PROPOSED POLYMERIZED HMA SURFACE COURSE, MIX 'F', N90, (IL.-9.5mm), 1 3/4"

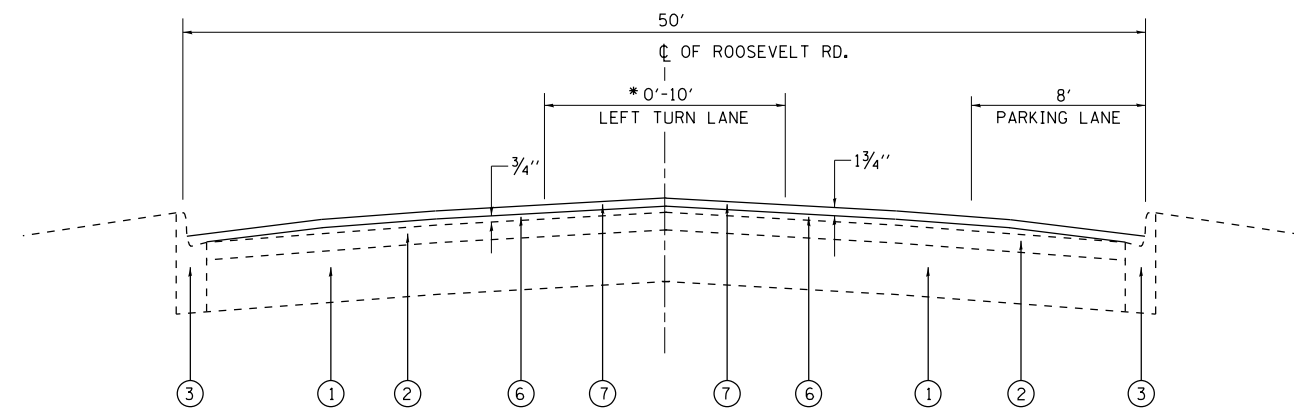

PROPOSED TYPICAL SECTION

STA. 71+00 TO STA. 100+16

* AT KOSTNER AVE. & KEELER AVE. & PULASKI (WEST SIDE ONLY)

FILE NAME =	USER NAME = gaglianob	DESIGNED -	REVISED -
et:\pw\work\p\dot\gaglianob\d0365155\DI	0514-sh-typical.dgn	DRAWN -	REVISED -
Default	PLOT SCALE = 100.0000' / in.	CHECKED -	REVISED -
	PLOT DATE = 3/5/2014	DATE -	REVISED -

**STATE OF ILLINOIS
DEPARTMENT OF TRANSPORTATION**

**TYPICAL CROSS SECTION
ROOSEVELT ROAD (LARAMIE AVENUE TO PULASKI ROAD)**

SCALE: NONE SHEET OF SHEETS STA. TO STA.

F.A.P. RTE.	SECTION	COUNTY	TOTAL SHEETS	SHEET NO.
347	2013-070 RS	COOK	25	6
				CONTRACT NO. 60X47
ILLINOIS FED. AID PROJECT				