

SIGN TABLE

| SIGN | DIMENSIONS |
|--------|--------------------------|
| R10-3b | 9" (228mm) X 12" (305mm) |
| R10-3d | 9" (228mm) X 12" (305mm) |
| R10-3e | 9" (228mm) X 15" (381mm) |

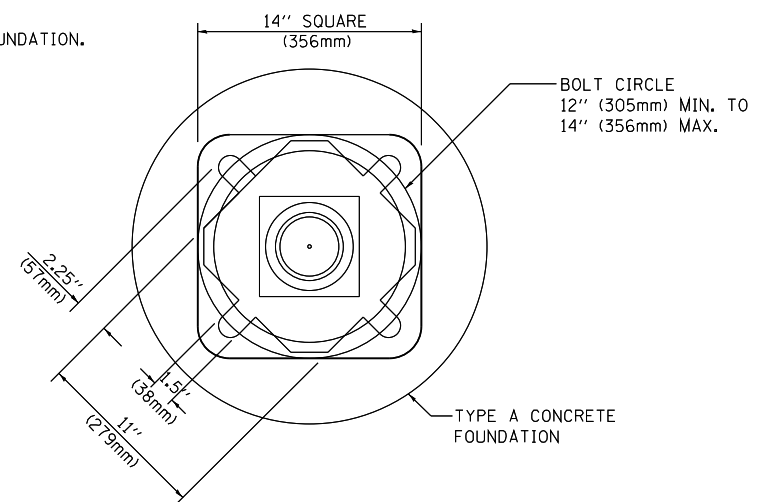

BOLT PATTERN

PEDESTRIAN PUSH BUTTON POST, TYPE A

| | | | |
|---|---------------------|------------------|----------------------|
| FILE NAME = | USER NAME = footemj | DESIGNED - DAG | REVISED - DAG 1-1-14 |
| ca:\pwwork\pwwork\footemj\d0108315\ts05.dgn | | DRAWN - GND | REVISED - |
| PLOT SCALE = 50.0000' / in. | | CHECKED - DAD | REVISED - |
| PLOT DATE = 1/13/2014 | | DATE - 10/1/2012 | REVISED - |

**STATE OF ILLINOIS
DEPARTMENT OF TRANSPORTATION**

| | | | |
|--|-------------------------|------|---------|
| DISTRICT ONE STANDARD TRAFFIC SIGNAL DESIGN DETAILS | | | |
| SCALE: NONE | SHEET NO. 7 OF 7 SHEETS | STA. | TO STA. |

| | | | | |
|---|------------|--------|---------------------------|-----------|
| F.A. RTE. | SECTION | COUNTY | TOTAL SHEETS | SHEET NO. |
| | 2013-076TS | COOK | 65 | 15 |
| TS-05 | | | CONTRACT NO. 60X65 | |
| FED. ROAD DIST. NO. 1 ILLINOIS FED. AID PROJECT | | | | |