

NOTE:
WHEN MILLING OPERATIONS PRODUCE A ROUNDED EDGE, THEN A SAW CUT SHALL BE USED TO MANUFACTURE A PERPENDICULAR EDGE AS SHOWN IN THE DETAIL. THE ENGINEER SHALL BE THE SOLE JUDGE CONCERNING THE USE OF THIS DETAIL.

HMA DETAIL AT BUTT JOINTS

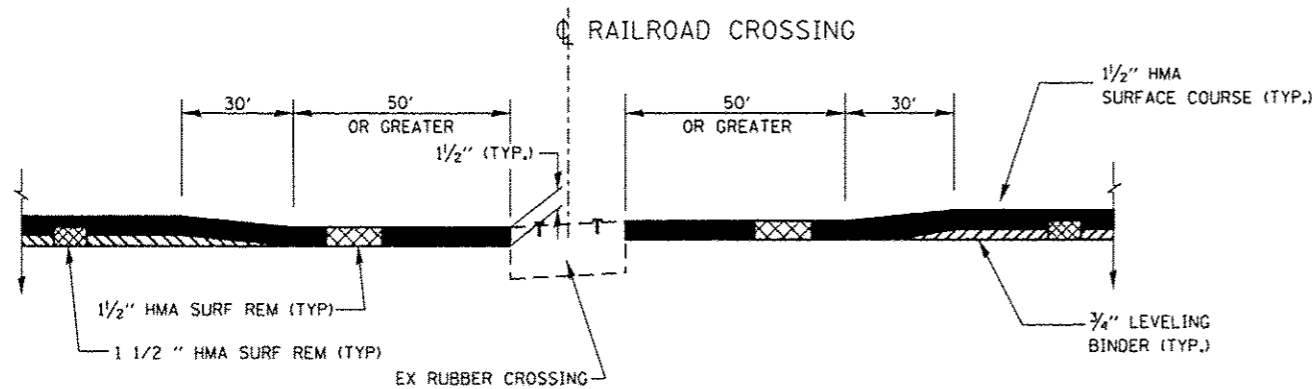

MILLING & RESURFACING DETAIL AT RAILROAD GRADE CROSSING

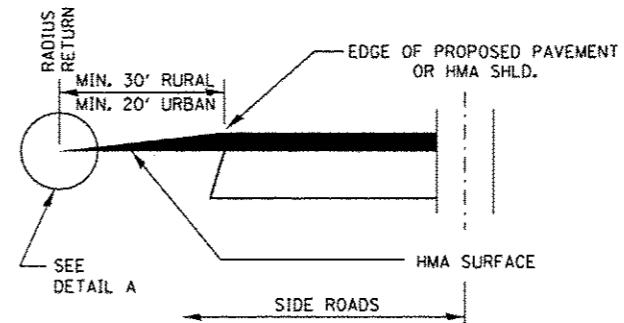
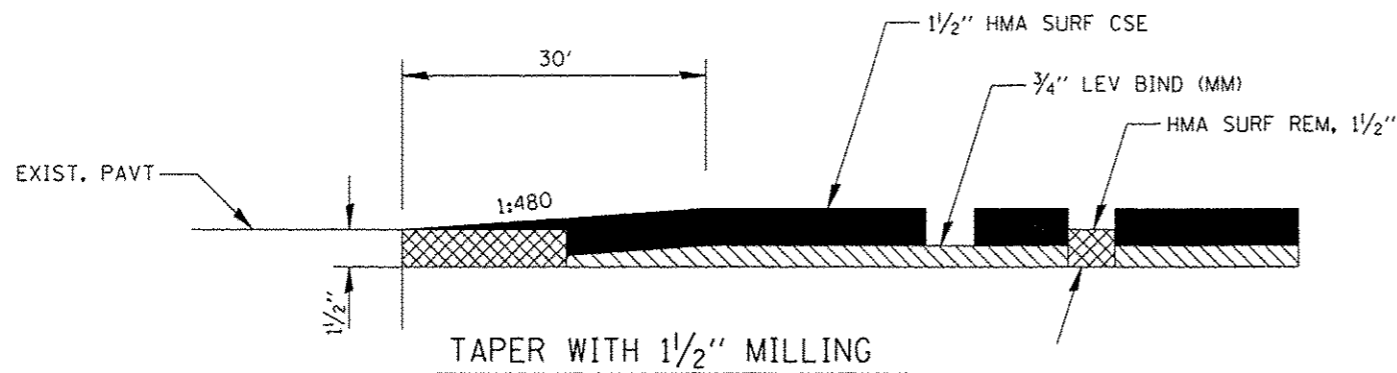

SECTION A-A DETAILS AT SIDE ROADS

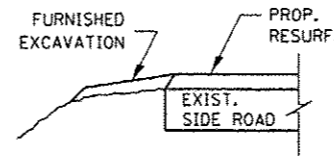

SECTION B-B

THE COST OF REMOVAL AT EXISTING HMA OR P.C.C. LOCATIONS SHALL BE PAID FOR PER SQ. YD. BY THE APPROPRIATE PAY ITEM. REMOVAL AT THE EXISTING AGG. LOCATIONS SHALL BE FEATHER TAPERED.

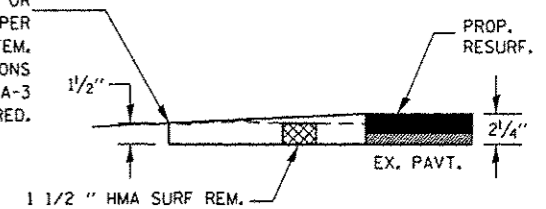

DETAIL A

SIDERoads IN RURAL SECTION, IN URBAN SECTION MILLING & RESURFACING WILL BE 2 1/4"

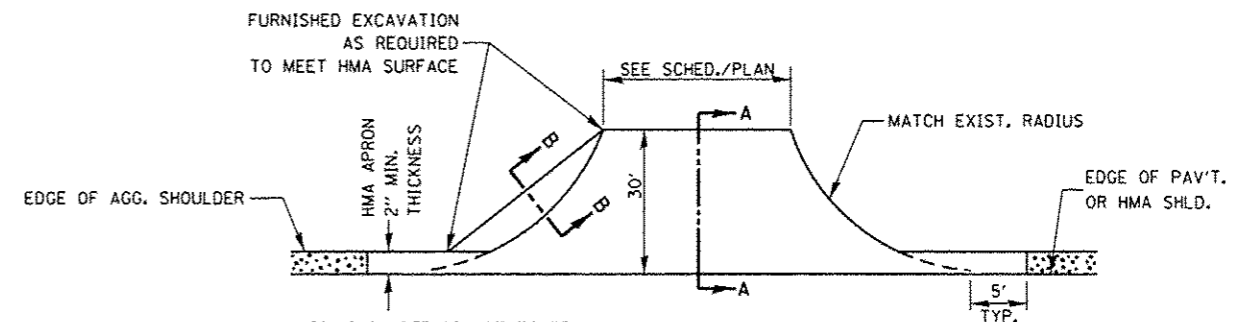

PROP. HMA SHLD. SHALL NOT BE CONSTRUCTED THRU HMA SIDERoads.

PLAN AT SIDE ROADS

FILE NAME :	USER NAME : duncanbd	DESIGNED -	REVISED -	STATE OF ILLINOIS DEPARTMENT OF TRANSPORTATION	DETAILS		F.A.P. RTE.	SECTION	COUNTY	TOTAL SHEETS	SHEET NO.
c:\pwork\pwork\duncanbd\08130229\036	952-shr-detail.dgn	DRAWN -	REVISED -		68	28RS-4	DEKALB	27	22		
	PLOT SCALE = 100.0000' / in.	CHECKED -	REVISED -		SCALE: SHEET NO. 2 OF 7 SHEETS STA. TO STA.			CONTRACT NO. 66952			
	PLOT DATE = 12/6/2013	DATE -	REVISED -		ILLINOIS FED. AID PROJECT						