

NORTH BOUND IL 6 RAMPS

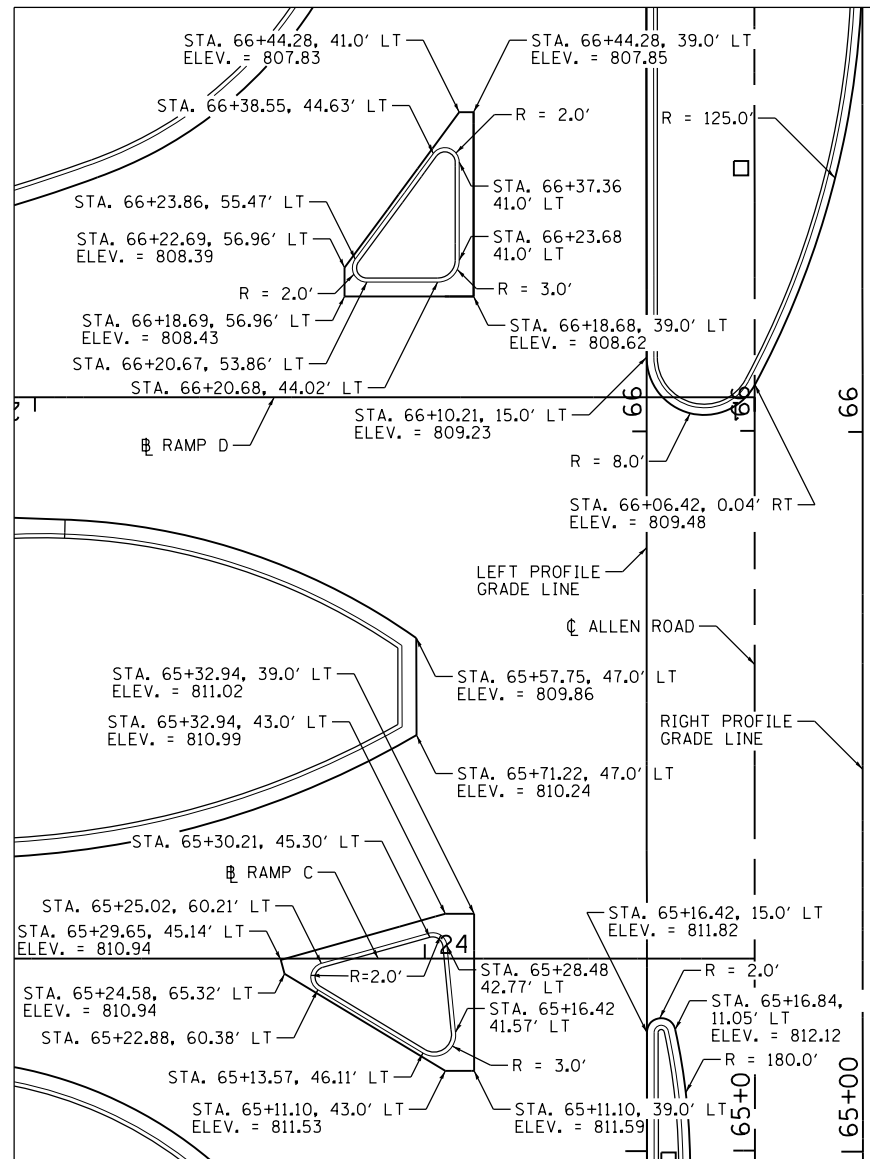

SOUTH BOUND IL 6 RAMPS

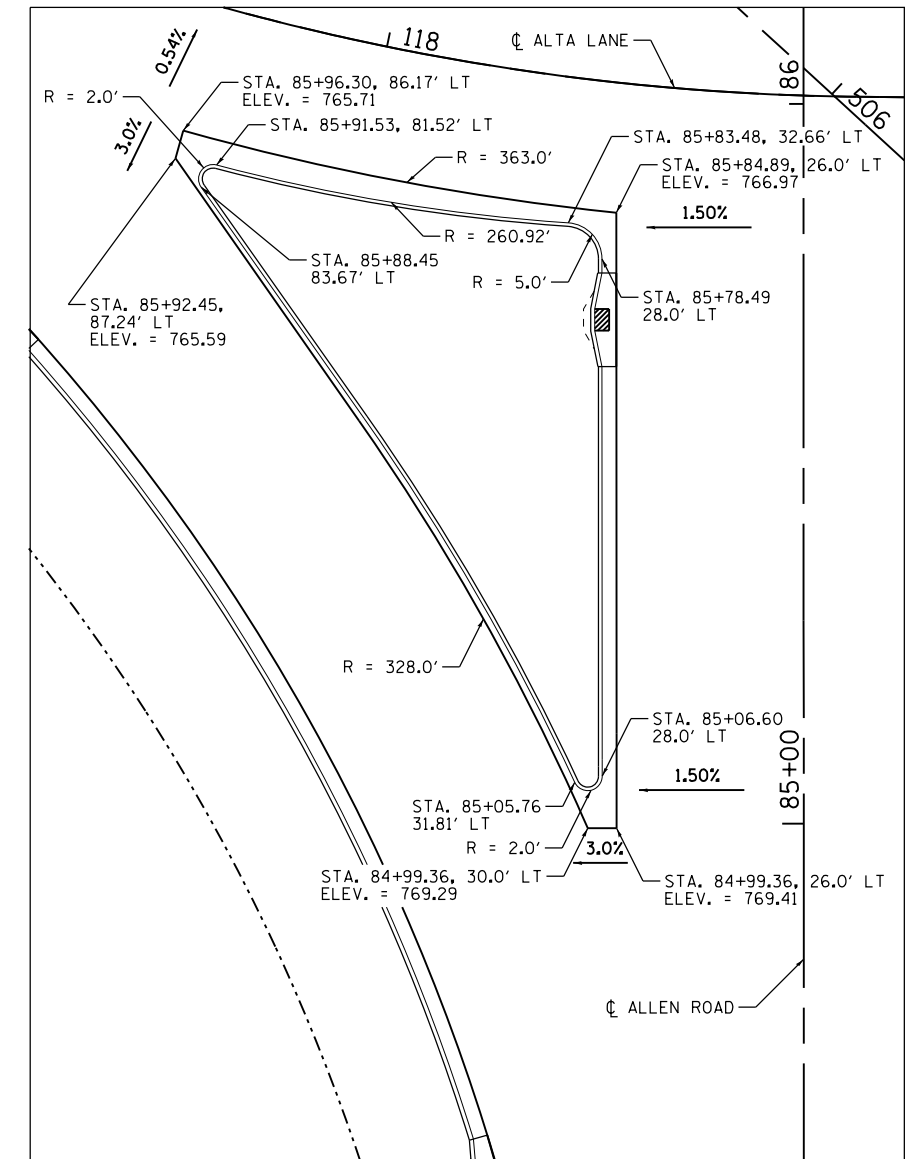

ALTA LANE

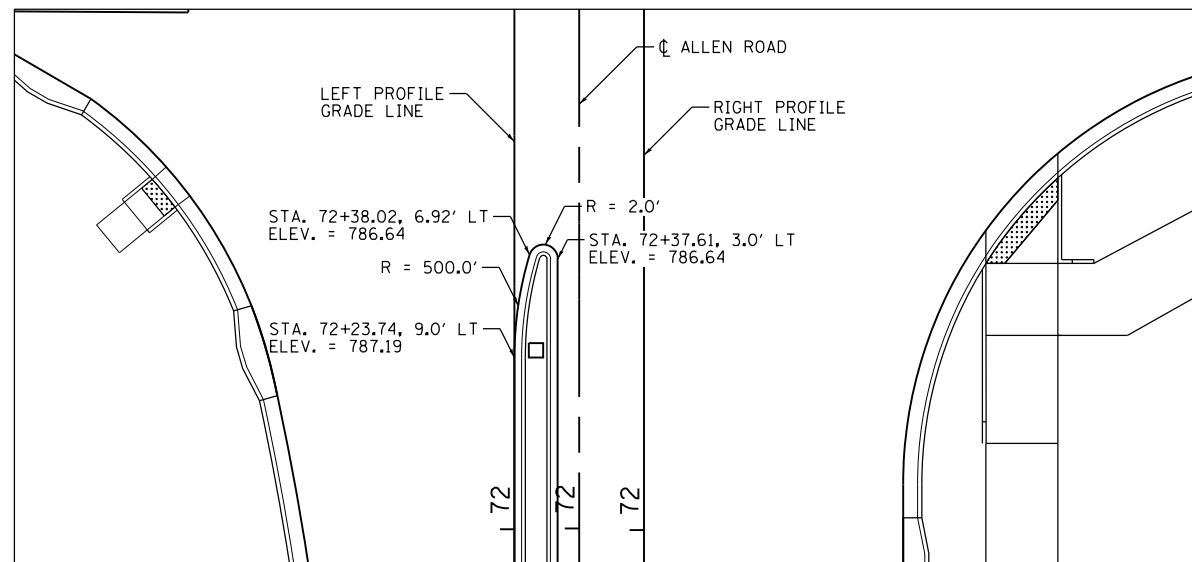

VAN WINKLE WAY



NOT TO SCALE

NOTE:
STATIONS AND OFFSETS ARE BASED ON THE CL ALLEN ROAD ALIGNMENT.

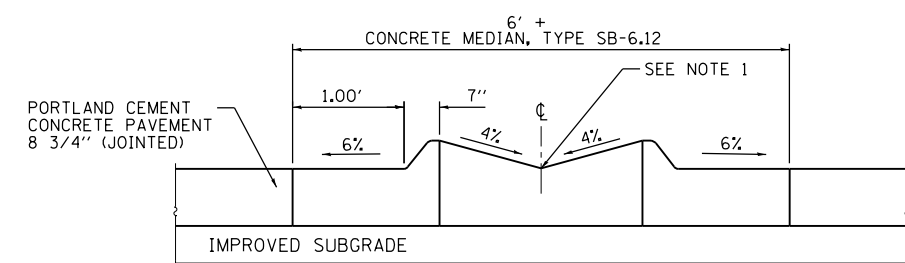

NOTES:
1. USE INVERTED CROWN WHEN MEDIAN WIDTH IS GREATER THAN 6'.
2. USE A 2.0% NORMAL CROWN WHEN MEDIAN WIDTH EQUALS 6'.

MEDIAN DETAIL

FILE NAME =	USER NAME = jeandrews	DESIGNED -	REVISED -
S:\237\2013\23713009\00\AllenRdPhI\CADD	CADD Sheets\0468683-sht:pavtelev4-median	DRAWN -	REVISED -
Default	PLOT DATE = 1/28/2014 3:14:49 PM	CHECKED -	REVISED -
		DATE -	REVISED -

F.A.U. R.T.E.	SECTION	COUNTY	TOTAL SHEETS	SHEET NO.
6584	105: (72-7HB)BY	PEORIA	487	222
6585	CONTRACT NO. 68683			