

NOTES:

1. ALL NECESSARY REVISIONS TO THE WIRING SHOWN ON THIS SHEET SHALL BE MADE AT NO ADDITIONAL COST TO THE DEPARTMENT AND TO THE SATISFACTION OF THE ENGINEER.

□ 50W LED LUMINAIRE

WIRING DIAGRAM (PROPOSED CONTROLLER # 2)

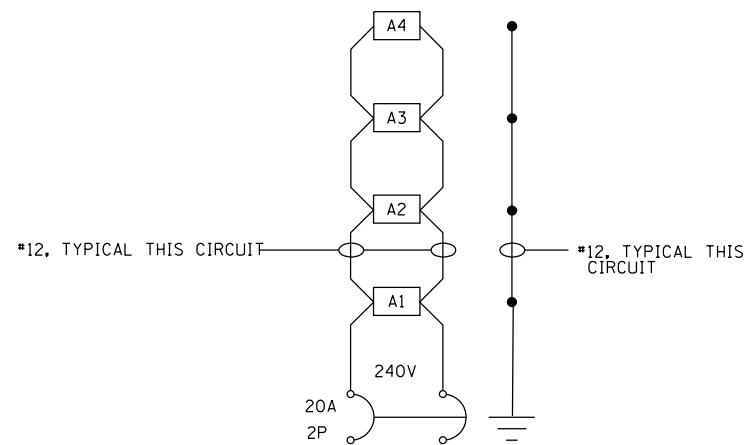

LIGHTING CKT A (PROPOSED)  
 PROPOSED LIGHTING CONTROLLER POLE MOUNTED  
 ENERGIZE DURING NIGHT TIME ONLY  
 ROCK ISLAND TRAIL TUNNEL

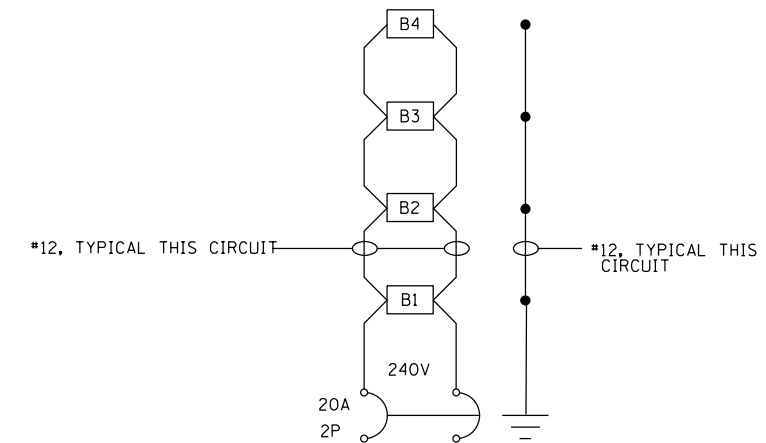

LIGHTING CKT B (PROPOSED)  
 PROPOSED LIGHTING CONTROLLER POLE MOUNTED  
 ENERGIZE ALL THE TIME  
 ROCK ISLAND TRAIL TUNNEL

FILE NAME =	USER NAME = baswanson	DESIGNED -	REVISED -
S:\237\2013\23713009\00\A11enRdPh11\CADD	CADD Sheets\0468683-sht-lighting 19.dgn	DRAWN -	REVISED -
Default	PLOT SCALE = 2.0000' / in.	CHECKED -	REVISED -
	PLOT DATE = 1/29/2014 12:12:29 PM	DATE -	REVISED -

ALLEN ROAD IMPROVEMENTS			
LIGHTING - WIRING DIAGRAM DETAILS			
SCALE:	SHEET 19	OF 19 SHEETS	STA. TO STA.

F.A.U. RTE.	SECTION	COUNTY	TOTAL SHEETS	SHEET NO.
6584	105: (72-7HB)BY	PEORIA	487	287
6585	CONTRACT NO. 68683			
ILLINOIS FED. AID PROJECT				